

**Model GD402
Gas Density Meter**

IM 11T03E01-01E

Introduction

The manual is applied to the following product.

Detector: GD40G (General Purpose), GD40R (TIIS) (Style S2),
GD40T (FM), GD40V (CSA) (Style S1)

Converter: GD402G (General Purpose), GD402R (TIIS),
GD402T (FM), GD402V (CSA) (Style S2)

Note: When using GD40/402 as CE marking compliance product, select GD40G and GD402G.

The related documents are as follows.

General Specifications: GS 11T3E1-01E

User's Manual: IM 11T03E01-01E (this manual)

* the "E" in the document number is the language code.

An exclusive User's Manual might be attached to the products whose suffix codes or option codes contain the code "Z" (made to customers' specifications). Please read it along with this manual.

The GD402 gas density meter and the GD40 detector not only provide continuous measurement of gas density, but also several other valuable parameters, including specific gravity and molecular weight. The GD40 detector is designed for intrinsically safe and flame-proof, explosion protected applications. It is designed to be virtually maintenance free for all accepted applications.

The GD402 is a rugged microprocessor-based converter designed in two versions to meet both general area and explosion-proof application requirements. In addition to the display of several key data items, the converter also provides the choice of three different means for calibration: automatic; semi-automatic and one-touch manual operation.

● Cross-Checking the Specifications



CAUTION

The GD402 gas density meter is shipped after adjusting the both of detector and converter in pairs. When installation, confirm whether the serial number on both of converter and detector are in pairs or not. If mismatched in pairs, converter is to be out of order. When converter or detector supplied individually, enter the detector constants, described on inside the lid of the GD40, into converter so that the GD402 is going to be well.

In detail, please refer to Figure 5.30, Figure 6.31 or Figure 7.28.

Upon delivery of the purchased product, unpack it carefully and make sure it is completely free from damage that may have occurred during transport. It must be shipped in strict conformance to the purchaser's specifications. By way of precaution, confirm that the equipment is the exact model you ordered. Also check that all accessory components are included, when confirming the specifications, refer to the model and suffix codes indicated on the nameplate on the equipment. For a description of the model and suffix codes, refer to Chapter 1, "Specifications."

● Consideration of Operation Parameters

The GD402 operates with the same parameters set when it was delivered (default data), when it is put into operation under these conditions.

Before starting measurement, check whether or not the default data meets your operating conditions. If necessary, re-set the parameters to suit your operating requirements. To check the defaults, make use of the sheet, "Records of GD402's Operation Parameter Settings," in the back of this manual. It is advisable that, if any of the operation parameter settings have been changed, the new data be noted in this record.

● Information Covered in This Manual

This manual covers all of the information for handling the GD402 converter and the GD40 detector, including instructions on installation, operation, setting of operation parameters, inspection and maintenance.

● Equipments

The GD402 should only be used with equipment that meets the relevant IEC, American, Canadian standard. Yokogawa accepts no responsibility for the misuse of this unit.



CAUTION

Modification and adaptation of the instrument's parts, wiring and construction are prohibited.



WARNING

- Power Supply
Ensure the power supply voltage matches instrument before turning ON the power.
- Protective grounding
Make sure to connect the protective grounding to prevent an electric shock before turning ON the power.
- Necessity of protective grounding
Never cut off the internal or external protective grounding wire or disconnect the wiring of protective grounding terminal. Doing so poses a potential shock hazard.
- Defect of Protective Grounding and Fuse
Do not operate the instrument when protective grounding or fuse might be defective.
- Fuse
To prevent a fire, make sure to use fuses with specified standard (voltage, current, type).
Before replacing the fuses, turn off the power and disconnect the power source.
Do not use a different fuse or short-circuit the fuse holder.
- Do not Remove any Covers
There are some areas with high voltages. Do not remove any cover if the power supply is connected. The cover should be removed by qualified personnel only.

■ Safety, Protection, and Modification of the Product

- In order to protect the system controlled by the product and the product itself and ensure safe operation, observe the safety precautions described in this user’s manual. We assume no liability for safety if users fail to observe these instructions when operating the product.
- If this instrument is used in a manner not specified in this user’s manual, the protection provided by this instrument may be impaired.
- If any protection or safety circuit is required for the system controlled by the product or for the product itself, prepare it separately.
- Be sure to use the spare parts approved by Yokogawa Electric Corporation (hereafter simply referred to as YOKOGAWA) when replacing parts or consumables.
- Modification of the product is strictly prohibited.
- The following safety symbols are used on the product as well as in this manual.



WARNING

This symbol indicates that an operator must follow the instructions laid out in this manual in order to avoid the risks, for the human body, of injury, electric shock, or fatalities. The manual describes what special care the operator must take to avoid such risks.



CAUTION

This symbol indicates that the operator must refer to the instructions in this manual in order to prevent the instrument (hardware) or software from being damaged, or a system failure from occurring.

CAUTION

This symbol gives information essential for understanding the operations and functions.

NOTE

This symbol indicates information that complements the present topic.



This symbol indicates Protective Ground Terminal.



This symbol indicates Function Ground Terminal. Do not use this terminal as the protective ground terminal.



Alternating current



Direct current

[Notational Conventions Specific to This Manual]

The following notational conventions apply to the representations of operation keys, information shown on the display, and information indicated on the product itself when they are discussed specifically in the text of this manual.

● Operation Keys

Indicated with brackets [] or " " as: [YES] Key or "YES" key

● Information Shown on Display

Indicated with braces [] as:

[HOLD], meaning the status

[YES], meaning the indicator on an operation key

[CALIB], meaning a message

[205] (lit) or [205] (blinking), meaning the data item shown along with its state

- **Information Indicated on Product**

Indicated with angle brackets < > as: <■> (lit) or <□> (unlit), meaning the contact output indicator lamp along with its state

<MEASURE> mode, meaning the mode of measurement

- **Information on the State of Blinking**

Indicated in shaded typography as:

(blinking) 102 , in contrast to (lit) 102

◆ CE marking products

■ Identification Tag

This manual and the identification tag attached on packing box are essential parts of the product. Keep them together in a safe place for future reference.

■ Users

This product is designed to be used by a person with specialized knowledge.

■ How to dispose the batteries

This is an explanation about the new EU Battery Directive (DIRECTIVE 2006/66/EC). This directive is only valid in the EU.

Batteries are included in this product. Batteries incorporated into this product cannot be removed by yourself. Dispose them together with this product.

When you dispose this product in the EU, contact your local Yokogawa Europe B.V. office. Do not dispose them as domestic household waste.

Battery type: Manganese dioxide lithium battery



Notice : The symbol (see above) means they shall be sorted out and collected as ordained in ANNEX II in DIRECTIVE 2006/66/EC.

■ Product Disposal

The instrument should be disposed of in accordance with local and national legislation/regulations.

■ Authorized Representative in EEA

The Authorized Representative for this product in EEA is Yokogawa Europe B.V. (Euroweg 2, 3825 HD Amersfoort, The Netherlands).

◆ After-sales Warranty

- Do not modify the product.
- Yokogawa warrants the product for the period stated in the pre-purchase quotation. Yokogawa shall conduct defined warranty service based on its standard. When the customer site is located outside of the service area, a fee for dispatching the maintenance engineer will be charged to the customer.
- During the warranty period, for repair under warranty carry or send the product to the local sales representative or service office. Yokogawa will replace or repair any damaged parts and return the product to you.
 - Before returning a product for repair under warranty, provide us with the model name and serial number and a description of the problem. Any diagrams or data explaining the problem would also be appreciated.
 - If we replace the product with a new one, we won't provide you with a repair report.
- In the following cases, customer will be charged repair fee regardless of warranty period.
 - Failure of components which are out of scope of warranty stated in instruction manual.
 - Failure caused by usage of software, hardware or auxiliary equipment, which Yokogawa Electric did not supply.
 - Failure due to improper or insufficient maintenance by user.
 - Failure due to modification, misuse or outside-of-specifications operation which Yokogawa does not authorize.
 - Failure due to power supply (voltage, frequency) being outside specifications or abnormal.
 - Failure caused by any usage out of scope of recommended usage.
 - Any damage from fire, earthquake, storms and floods, lightning, disturbances, riots, warfare, radiation and other natural changes.
- Yokogawa does not warrant conformance with the specific application at the user site. Yokogawa will not bear direct/indirect responsibility for damage due to a specific application.
- Yokogawa Electric will not bear responsibility when the user configures the product into systems or resells the product.
- Maintenance service and supplying repair parts will be covered for five years after the production ends. For repair for this product, please contact the nearest sales office described in this instruction manual.

Model GD402

Gas Density Meter

IM 11T03E01-01E 11th Edition

CONTENTS

Introduction	i
◆ CE marking products	v
◆ After-sales Warranty	vi
1. SPECIFICATIONS	1-1
1.1 Specifications.....	1-1
1.1.1 General Specifications.....	1-1
1.1.2 GD40G, T, V, R Detector.....	1-4
1.1.3 GD402G, T, V, R Converter.....	1-4
1.2 Model and Suffix Codes	1-6
1.2.1 Gas Density Converter	1-6
1.2.2 Gas Density Detector.....	1-6
1.2.3 Bracket for Connection with External Cables (For Explosion-proof use)	1-7
1.2.4 Two-core, Double-Shielded Cable.....	1-7
1.2.5 Brain Terminal (Optional)	1-8
1.2.6 Pressure transmitter (Optional).....	1-8
1.3 External Views and Dimension.....	1-9
1.3.1 GD402G Converter (General purpose)	1-9
1.3.2 Pipe- and Wall-Mounting Bracket (Optional)	1-10
1.3.3 GD402T, V, R Converter (Explosion-proof)	1-11
1.3.4 GD40 Detector	1-12
1.3.5 Detector Unit (Intrinsically Safe, Explosion-proof).....	1-13
2. INSTALLATION, WIRING AND PIPING.....	2-1
2.1 Installing the Detector	2-1
2.1.1 Selecting the Location.....	2-1
2.1.2 GD40T (FM Explosion-proof and Intrinsically Safe Approval).....	2-2
2.1.3 GD40V (CSA Explosion-proof and Intrinsically Safe Approval)	2-3
2.1.4 Mounting the Detector.....	2-4
2.2 Installing the Converter	2-5
2.2.1 Selecting the Location.....	2-5
2.2.2 GD402T (FM Explosion-proof Approval)	2-6
2.2.3 GD402V (CSA Explosion-proof Approval).....	2-7
2.2.4 Mounting the Converter	2-8
2.3 Piping	2-10

2.4	Wiring	2-12
2.4.1	Wiring Procedure	2-12
2.4.2	Cables Wired to Power Supply	2-16
2.4.3	Cables Wired to Outputs	2-17
2.4.4	Cables Wired to Contact I/Os	2-18
2.4.5	Cable Wired to GD40□ Detector	2-19
2.4.6	Wiring to Model EJX310A pressure transmitter	2-20
2.4.7	Cables Wired to the Ground	2-20
3.	OPERATION	3-1
3.1	Preparation for Operation	3-1
3.1.1	Inspecting Installation, Piping and Wiring Workmanship	3-1
3.1.2	Supplying Power	3-2
3.1.3	Display on Operation Panel and Operation Keys	3-3
3.1.4	Basic Key Operation	3-4
3.1.5	Checking the Setting Parameters	3-6
3.1.6	Calibrating the Analyzer for Correct Readings	3-6
3.1.7	Checking the Analyzer for Performance	3-7
3.2	Normal Operation	3-8
3.2.1	Starting Operation.....	3-8
3.2.2	Corrective Actions in Case of Failure.....	3-8
3.2.3	Inspection and Maintenance.....	3-9
3.3	Shutdown and Restart	3-9
3.3.1	Measures for Shutdown.....	3-9
3.3.2	Measures for Restarting	3-9
4.	FUNCTIONS	4-1
4.1	Summary of Setting Operations	4-1
4.1.1	Measurement, Operation, Setting and Service	4-1
4.1.2	Key Operations	4-1
4.1.3	Points to Be Noted When Making Settings.....	4-2
4.2	Setting Lists	4-2
5.	DENSITY / PARAMETER SETTING	5-1
5.1	Setting Parameters	5-2
5.1.1	Setting Parameters at Measurement Level	5-2
5.1.2	Setting Parameters at Operation Level	5-3
5.1.3	Setting Parameters at Setting Level	5-4
5.1.4	Setting Parameters at Service Level	5-5
5.2	Parameter Setting	5-6
5.2.1	Parameter Setting at Operation Level	5-6
5.2.2	Parameter Setting at Setting Level	5-10
5.2.3	Parameter Setting at Service Level	5-16
6.	CALORIE / PARAMETER SETTING	6-1
6.1	Setting Parameters	6-2

6.1.1	Setting Parameters at Measurement Level	6-2
6.1.2	Setting Parameters at Operation Level	6-3
6.1.3	Setting Parameters at Setting Level	6-4
6.1.4	Setting Parameters at Service Level	6-5
6.2	Parameter Setting	6-7
6.2.1	Parameter Setting at Operation Level	6-7
6.2.2	Parameter Setting at Setting Level	6-12
6.2.3	Parameter Setting at Service Level	6-16
7.	HYDROGEN PURITY/PARAMETER SETTING	7-1
7.1	Setting Parameters	7-2
7.1.1	Setting Parameters at Measurement Level	7-2
7.1.2	Setting Parameters at Operation Level	7-2
7.1.3	Setting Parameters at Setting Level	7-3
7.1.4	Setting Parameters at Service Level	7-4
7.2	Parameter Setting	7-6
7.2.1	Parameter Setting at Measurement Level	7-6
7.2.2	Parameter Setting at Operation Level	7-7
7.2.3	Parameter Setting at Setting Level	7-10
7.2.4	Parameter Setting at Service Level	7-14
8.	DENSITY /CALIBRATION PROCEDURE	8-1
8.1	Basic Calibration Procedure.....	8-1
8.2	Preparation for Calibration	8-1
8.2.1	Setting Type of Calibration and Checking Valve Operation.....	8-1
8.2.2	Setting Calibration Data	8-3
8.3	Calibration	8-4
8.3.1	Semi-automatic Calibration	8-4
8.3.2	Manual Calibration	8-5
8.3.3	Automatic Calibration.....	8-6
9.	CALORIE /CALIBRATION PROCEDURE.....	9-1
9.1	Basic Calibration Procedure.....	9-1
9.2	Preparation for Calibration	9-1
9.2.1	Setting Type of Calibration and Checking Valve Operation.....	9-1
9.2.2	Setting Calibration Data	9-3
9.3	Calibration	9-5
9.3.1	Semi-automatic Calibration	9-5
9.3.2	Manual Calibration	9-6
9.3.3	Automatic Calibration.....	9-7
10.	HYDROGEN PURITY /CALIBRATION PROCEDURE	10-1
10.1	Basic Calibration Procedure.....	10-1
10.2	Preparation for Calibration	10-1
10.3	Calibration	10-2

11.	INSPECTION AND MAINTENANCE	11-1
11.1	Routine Inspection and Maintenance.....	11-1
11.1.1	Checking Readings and Calibrating the Analyzer	11-1
11.1.2	Checking the Flowrate of Sample Gas	11-1
11.1.3	Periodic Replacement of the Detector's O-rings	11-1
11.1.4	Replacing the Fuse	11-2
11.1.5	Cleaning	11-2
11.2	Inspection In Case of Failure	11-3
11.2.1	Inspecting the Analyzer in an Alarm Status	11-3
11.2.2	Inspecting the Analyzer in a FAIL Status	11-4
	Customer Maintenance Parts List.....	CMPL 11T3E1-01E
	Customer Maintenance Parts List.....	CMPL 11T3E1-02E
	Customer Maintenance Parts List.....	CMPL 11T3E1-03E
	Revision Information	i

1. SPECIFICATIONS

1.1 Specifications

The specifications of the GD402 gas density meter as described below.

CE Certificate is approved for model GD402G, GD40G.

1.1.1 General Specifications

- **System Components**

(1) GD40G, T, V, R Detector: Rainproof for outdoor use (equivalent to IP65/NEMA4X)

(see note under "1.1.2 Ambient conditions" on page 1-5.)

Ambient Temperature : -10 to 60°C

Ambient Humidity : 5 to 95%RH

GD40G : General purpose detector. (Non-Explosion-proof)

Electrical connection : 1/2 NPT female

Process connection : 1/4 NPT female

GD40T : FM Explosion-proof and Intrinsically safe Approval.

Explosion-proof for Class I, Division 1, Groups B, C and D;

Dust Ignition-proof for Class II, III, Division 1, Groups E, F and G with

Intrinsically Safe sensor for Class I, II, III, Division 1, Groups B, C, D, E, F and G.

Applicable standards:

FM Class 3600:1998, FM Class 3610:2010, FM Class 3615:1989, FM Class

3810:2005, ANSI/ISA 60079-0:2009, ANSI/UL 60079-11:2009, ANSI/NEMA 250:1991

Enclosure : NEMA Type 4X

Temperature Code : T5

Electrical connection : 1/2 NPT female

Process connection : 1/4 NPT female

GD40V : CSA Explosion-proof and Intrinsically safe Approval.

Explosion-proof for Class I, Division 1, Groups B, C and D;

Dust Ignition-proof for Class II, III, Division 1, Groups E, F and G with Intrinsically

Safe sensor for Class I, II, III, Division 1, Groups B, C, D, E, F and G.

Applicable standards:

CAN/CSA-C22.2 No. 25-1966, CAN/CSA-C22.2 No. 30-M1986, CAN/CSA-C22.2

No. 94.2-15, CAN/CSA-C22.2 No. 157-92, CAN/CSA-C22.2 No. 1010.1-92

Enclosure : Type 4X

Temperature Code : T5

Electrical connection : 1/2 NPT female

Process connection : 1/4 NPT female

GD40R : TIIS Explosion-proof and Intrinsically safe Approval.

Explosion-proof code : Exd [ia] IIB+H₂T5

Temperature Code : T5

Electrical connection : G1/2 female

Process connection : Rc1/4

(2) GD402G, T, V, R Converter : Rainproof for outdoor use (equivalent to IP65 / NEMA 4X)

Ambient Temperature : -10 to 55°C

Ambient Humidity : 5 to 95%RH

GD402G : General purpose converter. (Non-Explosion-proof).

Electrical connection: 21mm (0.9inch) in diameter. Pg 13.5 cable glands included

GD402T : FM Explosion-proof Approval.

Explosion-proof for Class I, Division 1, Groups B, C and D;

Dust Ignition-proof for Class II, III, Division 1, Groups E, F and G.

Applicable standards:

FM Class 3600:1998, FM Class 3615:1989, FM Class 3810:1989, NEMA 250:1991

Enclosure : NEMA Type 4X

Temperature Code : T6

Electrical connection : 1/2 NPT female

GD402V : CSA Explosion-proof Approval.

Explosion-proof for Class I, Division 1, Groups B, C and D;

Dust Ignition-proof for Class II, III, Division 1, Groups E, F and G.

Applicable standards:

CAN/CSA-C22.2 No. 0-M91, CAN/CSA-C22.2 No. 0.4-M1982, CAN/CSA-C22.2 No. 0.5-1982, CAN/CSA-C22.2 No. 25-1966, CAN/CSA-C22.2 No. 30-M1986, CAN/CSA-C22.2 No. 94-M91, CAN/CSA-C22.2 No. 1010.1-92

Enclosure : Type 4X

Temperature Code : T6

Electrical connection : 1/2 NPT female

GD402R : TIIS Explosion-proof Approval.

Explosion-proof code : Exd IIB+H₂T6

Temperature Code : T6

Electrical connection : G3/4 female

(3) EJX310A Absolute pressure transmitter (optional)

See GS 01C25D01-01EN for EJX310A.

● Sample Gas conditions

Sample gas: All gases except for corrosive gas and acetylene gas.

Temperature: -10 to 50°C (non-condensing)

Pressure: Max. 588.5 kPa (abs)

Gas flow: 0.1 to 1 L/min

● Output Signals

Output 1: 4-20 mA DC

Isolated from inputs; load resistance: 600 Ω maximum (Load resistance of 250-550 Ω required when in the BRAIN communication mode.)

Output 2: 4-20 mA DC

Isolated from inputs; load resistance: 600 Ω maximum

● Power Supply

Rated voltage range: 100 to 240 V AC, 24 V DC

Allowable voltage range: 85 to 264 V AC, 21.6 to 26.4 V DC

Rated frequency: 50 or 60 Hz

Allowable frequency range: 47 to 63 Hz

● **Power Consumption**

Approximately 12 W.

● **Fuse**

250 V 1 A time lag type authorized VDE/SEMKO 100 to 240 V AC Model

250 V 2 A time lag type authorized VDE/SEMKO 24V DC Model

● **Safety, EMC, and RoHS conformity standards**

Installation Altitude: 2000 m or less

Category based on IEC 61010: II (Note)

Pollution degree based on IEC 61010: 2 (Note)

Note: Installation category, called over-voltage category, specifies impulse withstand voltage.

Category II is for electrical equipment.

Pollution degree indicates the degree of existence of solid, liquid, gas or other inclusions which may reduce dielectric strength. Degree 2 is the normal indoor environment.

Safety Standards:

EN 61010-1, EN 61010-2-030

*: Applied only when GD402G converter is used with GD40G detector.

EMC Standards:

EN 61326-1* Class A Table 2,

EN 61326-2-3, EN 61000-3-2, EN 61000-3-3

EMC Regulatory Arrangement in Australia and New Zealand (RCM) EN61326-1 Class A

Korea Electromagnetic Conformity Standard**

* : Influence of immunity environment (Criteria A): ±50% of F.S.

** : Applied only when GD402G converter is used with GD40G detector.

** : Applied only when GD402R converter is used with GD40R detector.

RoHS: EN 50581

● **Characteristics**

GD402 specification list

Item	Density kg/m ³	Density lb/ft ³	Specific Gravity	Molecular Weight	Concentration vol%
Range	0 - 6 (compensated) 0 - 60 (physical)	0 - 0.4 (compensated) 0 - 4 (physical)	0 - 5	0 - 140	0 - 100
Minimum Range	0.1	0.01	0.1	4	Concentration equivalent to 100 kg/m ³
Response Time 90%	approx. 5 sec	approx. 5 sec	approx. 5 sec	approx. 5 sec	approx. 5 sec
Linearity	+/-1% FS	+/-1% FS	+/-1% FS	+/-1% FS	+/- 1
Repeatability	+/- 0.001 or +/-0.5%FS *	+/- 0.0001 or +/-0.5%FS*	+/- 0.001 or +/-0.5%FS*	+/- 0.02 or +/-0.5%FS*	+/- 0.5% or Concentration equivalent to +/-0.001 kg/m ³ *
Long term stability	+/- 0.003/month	+/- 0.002/month	+/- 0.003/month	+/- 0.07/month	Concentration equivalent to +/- 0.003 kg/m ³ /month

*: Whichever is greater

Density is the basic measurement, the other representations are derived from the Density data.

Item	H ₂ in Air vol%	H ₂ in CO ₂ vol%	Air in CO ₂ vol%	Caloric value MJ/m ³	British Thermal Unit KBTU/ft ³
Range	85 - 100	0 - 100	0 - 100	0 - 130	0 - 3.5
Minimum Range	-	-	-	Caloric value equivalent to 0.100 kg/m ³	Caloric value equivalent to 0.100 kg/m ³
Response Time 90%	approx. 5 sec	approx. 5 sec	approx. 5 sec	approx. 5 sec	approx. 5 sec
Linearity	+/- 1	+/- 1	+/- 1	+/- 1%FS	+/- 1%FS
Repeatability	+/- 0.5	+/- 0.5	+/- 0.5	+/- 0.5%FS or Caloric value equivalent to 0.001kg/m ³ *	+/- 0.5%FS or Caloric value equivalent to 0.001 kg/m ³ *
Drift	+/- 0.5/month	+/- 0.5/month	+/- 0.5/month	Caloric value equivalent to +/- 0.003 kg/m ³ /month	Caloric value equivalent to +/- 0.0025/month

Caloric Value and BTU are possible representations of the Density.
GD402 does not contain table information, only a single mathematical equation.

*: Whichever is greater

1.1.2 GD40G, T, V, R Detector

- **Material exposed to gas**

SUS 316 stainless steel, Acrylonitrile Butadiene Rubber and Fluorine-contained Rubber (O-ring)

- **Ambient conditions**

Temperature: -10 to 60°C (14 to 140 °F)

Humidity: 5 to 95%RH

Installation: Pipe-mounted or on panel

Construction: Explosion-proof and Intrinsically safe. (See 1.1.1 “System Components”)

Though the detector construction makes it relatively insensitive to sudden changes in the gas temperature, extra precision can be achieved by keeping ambient temperature conditions as constant as possible. In measurements where optimum precision is required it is therefore not recommended to install the detector in an outdoors environment, especially not if such installation is prone to direct sunlight.

- **Finish**

Cover: Equivalent to Munsell 0.6GY3.1/2.0

Case: Equivalent to Munsell 2.5Y8.4/1.2

- **Weight**

Approximately 7 kg (with pipe mounting bracket)

- **Detector unit**

When the system is ordered to be used as a hydrogen purity meter, an optional pressure transmitter is required for pressure compensation.

- If /EJAJ1□, /EJAF2□, /EJAF3□ or, /EJAF4□ are ordered, the detector unit and the pressure transmitter and the tubing in between will all be integrated on a single mounting plate. This allows the space where the pressure transmitter is normally mounted to be used effectively for other purposes.

1.1.3 GD402G, T, V, R Converter

- **Display**

Reading: Digital (6 digits maximum; resolution: 0.0001 kg/m³)

Data items shown:

Measured value: Always on display.

Alarm indications: Abnormal concentration, abnormal pressure range of input and abnormal value of calibration.

Parameters for calibration: Time of calibration, settling time, starting time of calibration and calibration cycle

Self-diagnostic indications: Sensor oscillation shutdown, abnormal oscillation frequency of sensor, failure in sensor temperature detection, failure in A/D conversion stage and memory failure.

Alarm settings: The contact state can be set to either “normally open (NO)” or “normally closed (NC)” depending on the needs of the application.

Temperature: Temperature of gas being measured

- **Contact Outputs/Input**

Contact output: Signals for Maintenance, Fail, Hi/Lo alarms
Contact capacity: 250 V AC at 3 A or 30 V DC at 3 A

Contact input: Signal for switching between the Hydrogen Purity meter and the Replacement meter

- **Calibration**

Manual (one touch), Semi automatic, Automatic calibration

- **Communication**

Protocol: BRAIN communication
Data items that can be transmitted by the hand-held terminal are numerical data, such as concentration, temperature and pressure, alarm setpoint and self-diagnostic parameters.

- **Ambient Conditions**

Temperature: -10 to 55°C (14 to 131°F)
Humidity: 5 to 95%RH

- **Installation**

Non-Explosion-proof models: Pipe-, panel- or wall-mounted
Explosion-proof models: Pipe- or panel-mounted

- **Finish**

GD402G (general purpose):
Front cover: Equivalent to Munsell 0.6GY3.1/2.0
Case: Equivalent to Munsell 2.5Y8.4/1.2

GD402T, V, R (explosion-proof):
Equivalent to Munsell 0.6GY3.1/2.0

- **Weight**

GD402G (general purpose): Approx. 3 kg (including mounting bracket)
GD402T, V, R (explosion-proof): Approx. 15 kg (including mounting bracket)

- **Fuse**

250 V 1 A time lag type authorized VDE/SEMKO 100 to 240 V AC Model
250 V 2 A time lag type authorized VDE/SEMKO 24 V DC Model

1.2 Model and Suffix Codes

1.2.1 Gas Density Converter

[Style: S2]

Model	Suffix code	Option code	Description
GD402G	-----	-----	General purpose model, 6 cable glands included.
GD402T	-----	-----	FM certified explosion-proof model. Gland threads 1/2 NPT. No cable glands included.
GD402V	-----	-----	CSA certified explosion-proof model. Gland threads 1/2 NPT. No cable glands included.
GD402R	-----	-----	TIIS certified explosion-proof model. Gland threads G3/4. No cable glands included.
Power supply	-D	-----	24 V DC
	-A	-----	100-240 V AC
Label and approval	-E	-----	English label
	-J	-----	TIIS approval, English label (only GD402R)
Instruction Manual	-E	-----	English
Options (only GD402G)		/PA	Panel mounting
		/U	Universal (Pipe and Wall) Mounting
		/H	Hood

Note: Explosion-proof models, GD402T, V, R have only pipe mounting bracket as standard.

■ GD402□ Standard Accessory List

Model	Item	Qty	Part Number
GD402G	Fuse	1	A1512EF (Power Supply: 100-240 V AC) A1111EF (Power Supply: 24 V DC)
	Universal Mount Set	1	K9171SS
	Panel Mount Set	1	K9171ST
GD402R GD402T GD402V	Fuse	1	A1512EF (Power Supply: 100-240 V AC) A1111EF (Power Supply: 24 V DC)
	Bracket	1	K9214HD
	Bracket	1	K9214HE
	U-Bolt Assy	2	D0117XL-A
	Bolt	1	Y9835NU
	Bolt	2	Y9820NU

1.2.2 Gas Density Detector

[Style: S2]

Model	Suffix code	Option code	Description
GD40G	-----	-----	General purpose detector. 1/4 NPT gas threads and 1/2 NPT gland threads. No cable gland included. Mounting bracket included.
GD40R	-----	-----	TIIS certified explosion - proof detector. Rc1/4 gas threads and G1/2 gland threads. Cable gland included. Mounting bracket included.
Label approval	-E	-----	English label, no approval (only GD40G)
	-J	-----	TIIS approval, English label (only GD40R)
Options		/EJAJ1	TIIS certified EJX mounted with detector on mounting plate. Rc1/4 gas threads and G1/2 gland thread. Cable gland included.(only GD40R)
		/EJAJ1T	TIIS certified EJX mounted with detector on mounting plate. Rc1/4 gas threads and G1/2 gland thread. Cable gland included. EJX with TAG (only GD40R)
		/EJAF2	EJX mounted with detector on mounting plate. 1/4 NPT gas threads and 1/2 NPT gland threads. No cable gland included.(only GD40G)
		/EJAF2T	EJX mounted with detector on mounting plate. 1/4 NPT gas threads and 1/2 NPT gland threads. No cable gland included. EJX with TAG (only GD40G)

[Style: S1]

Model	Suffix code	Option code	Description
GD40T	-----	-----	FM certified explosion - proof detector. 1/4 NPT gas threads and 1/2 NPT gland thread. No cable gland included. Mounting bracket included
GD40V	-----	-----	CSA certified explosion - proof detector. 1/4 NPT gas threads and 1/2 NPT gland thread. No cable gland included. Mounting bracket included.
Options		/EJAF3	FM certified EJX mounted with detector on mounting plate.1/4 NPT gas threads and 1/2 NPT gland thread. No cable gland included. (only GD40T)
		/EJAF3T	FM certified EJX mounted with detector on mounting plate.1/4 NPT gas threads and 1/2 NPT gland thread. No cable gland included. EJX with TAG (only GD40T)
		/EJAF4	CSA certified EJX mounted with detector on mounting plate. 1/4 NPT gas threads and 1/2 NPT gland thread. No cable gland included. (only GD40V)
		/EJAF4T	CSA certified EJX mounted with detector on mounting plate. 1/4 NPT gas threads and 1/2NPT gland thread. No cable gland included. EJX with TAG (only GD40V)

■ GD40□ Standard Accessory

Item	Qty	Part Number
U-Bolt Assy *1	4	D0117XL-A
Bracket *1	1	K9214HD
Bracket *1	1	K9214HE
Gland *2	1	G9601AM

*1: Not supplied when option code "/EJAJ1□", "/EJAF2□", "/EJAF3□" or "/EJAF4□" is specified.

*2: Supplied only for GD40R.

1.2.3 Bracket for Connection with External Cables (For Explosion-proof use)

Part No.	Description
L9811LL	G3/4 explosion-proof cable gland. Cable's outside diameter 8 to 16 mm. Used for the GD402R converter.

Note: Specify the number of cable glands for converter in hazardous area

1.2.4 Two-core, Double-Shielded Cable

Normally two conductor shielded cable can be used, but when failure arises from noises disturbance, this cable is recommended for connection between the GD402 converter and GD40 detector.

Model	Suffix code	Description
GDW	-----	Two - core, double-shielded cable, both ends finished with cable pins.
Length	-L□□□	Length in meters, 500 meter maximum.

1.2.5 Brain Terminal (Optional)

Model	Suffix code	Option code	Description
BT200	-----	-----	Brain terminal *1
Printer	-N -P	----- -----	Standard type (without printer) With printer
—	00	-----	Always 00
Options		/□□	

*1: The BT200 has following accessories, two communication cables, one with IC clips and another with alligator clips, handy carrying case and five AA 1.5 V dry batteries.

■ OPTIONS FOR BT200

Options	Description	Option codes
Communication cable *1	With a 5-pin connector (for the signal conditioner)	/C1
Intrinsically safe type *1, *2	CSA Intrinsically safe approval Class I, Groups A, B, C and D Temp. Code : T4	/CS1

*1: Optional code /C1 can not be combined with /CS1.

*2: Applicable only for Model BT200-N00.

See GS 01C00A11-00EN for “BT200” brain terminal in detail.

1.2.6 Pressure transmitter (Optional)

/EJAJ1□ means TIIS certified EJX310A.

/EJAF2□ means general purpose model EJX310A.

/EJAF3□ means FM certified EJX310A.

/EJAF4□ means CSA certified EJX310A.

See GS 01C25D01-01EN for “EJX310A” pressure transmitter in detail if a different selection from pre-selected options seems necessary.

1.3 External Views and Dimension

1.3.1 GD402G Converter (General purpose)

Unit: mm (in.)

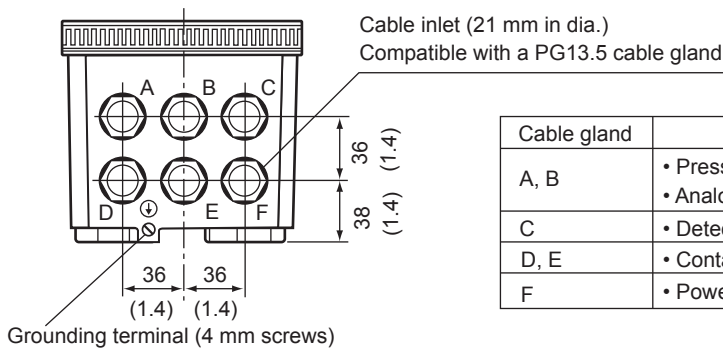
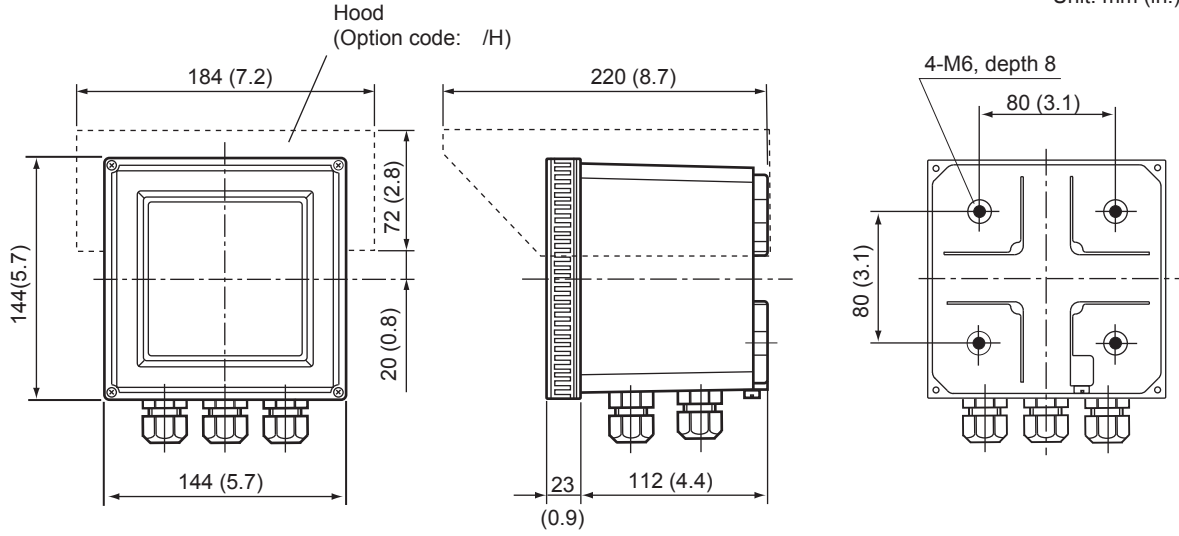

Cable gland	Connection
A, B	• Pressure transmitter • Analog output • Contact Input
C	• Detector
D, E	• Contact Output
F	• Power Supply

1.3.2 Pipe- and Wall-Mounting Bracket (Optional)

Unit: mm (in.)

Hardware for Pipe Mounting (Option code /U)

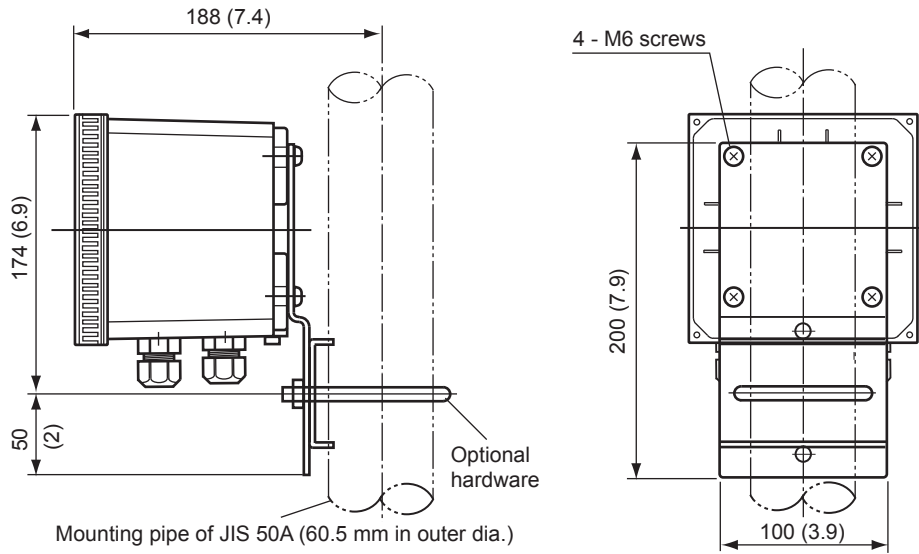

Hardware for Wall Mounting (Option code /U)

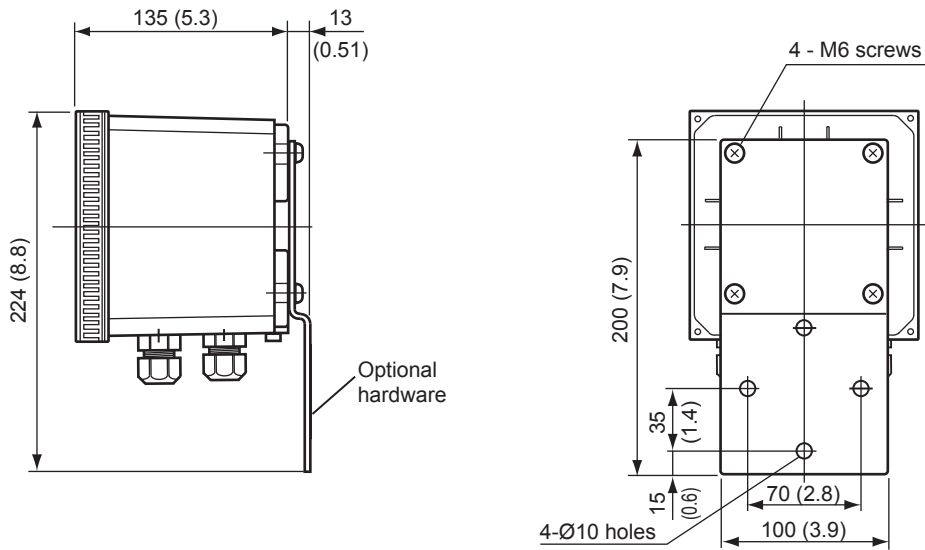

Hardware for Panel Mounting (Option code /PA)

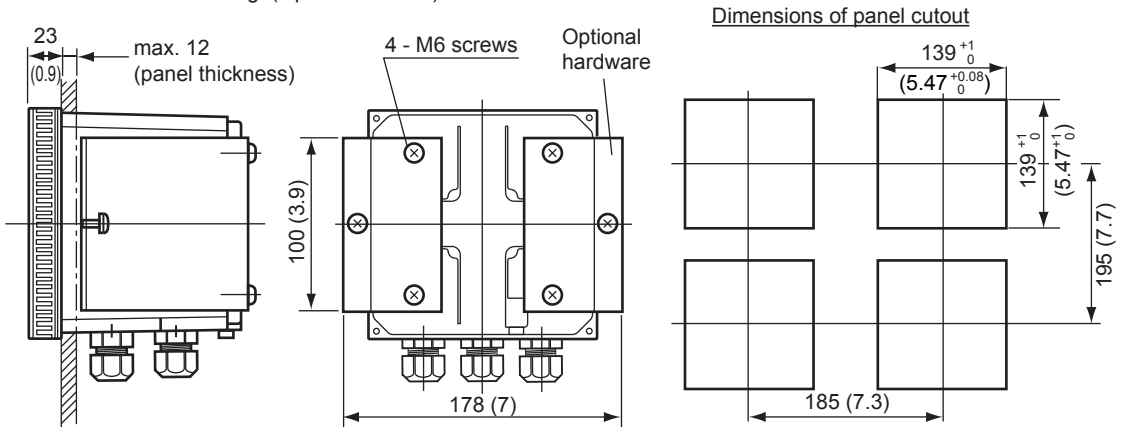

1.3.3 GD402T, V, R Converter (Explosion-proof)

Unit: mm (in.)

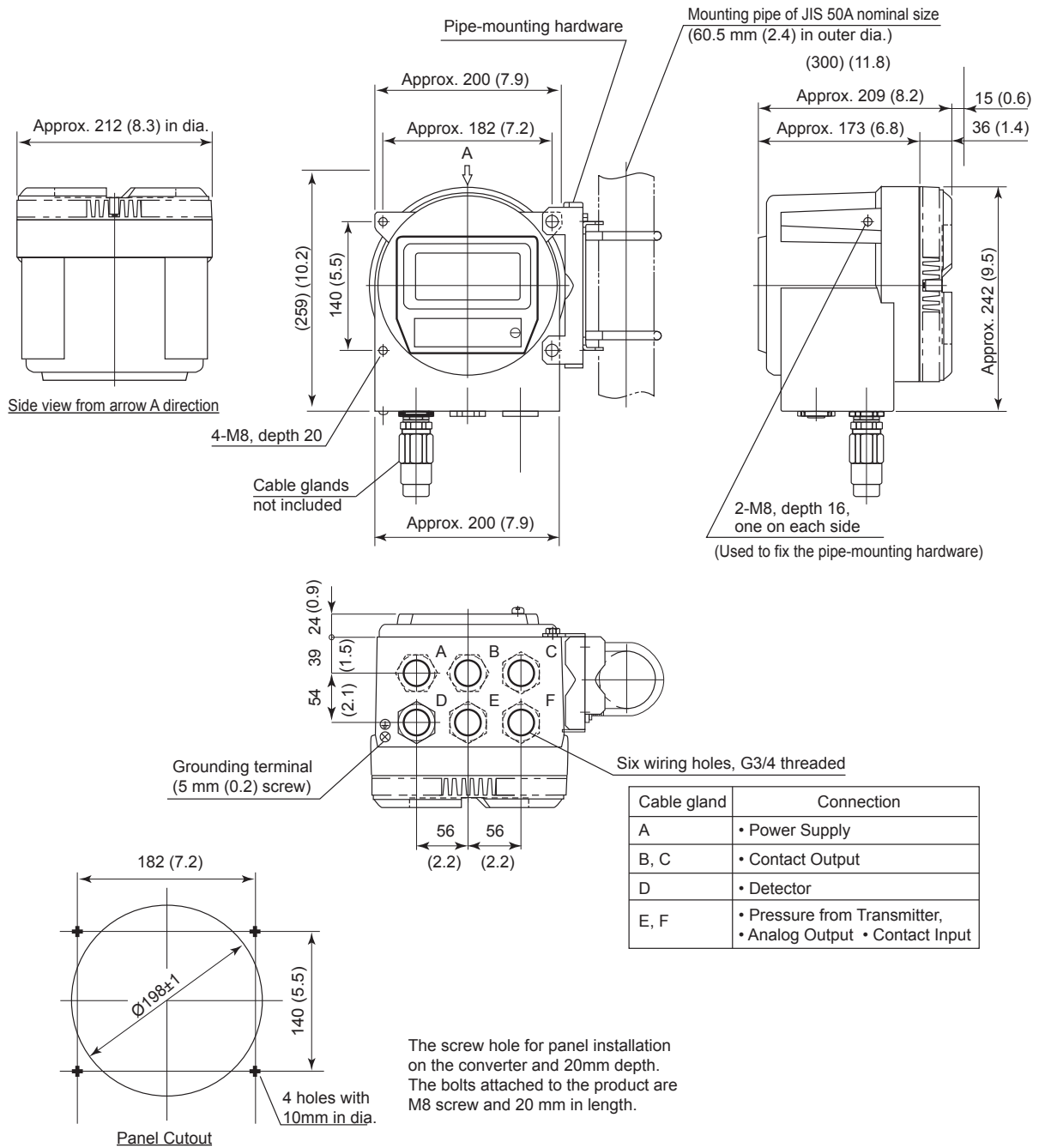

1.3.4 GD40 Detector

- Model GD40□-□ /EJAJ1, /EJAF2, /EJAF3, /EJAF4

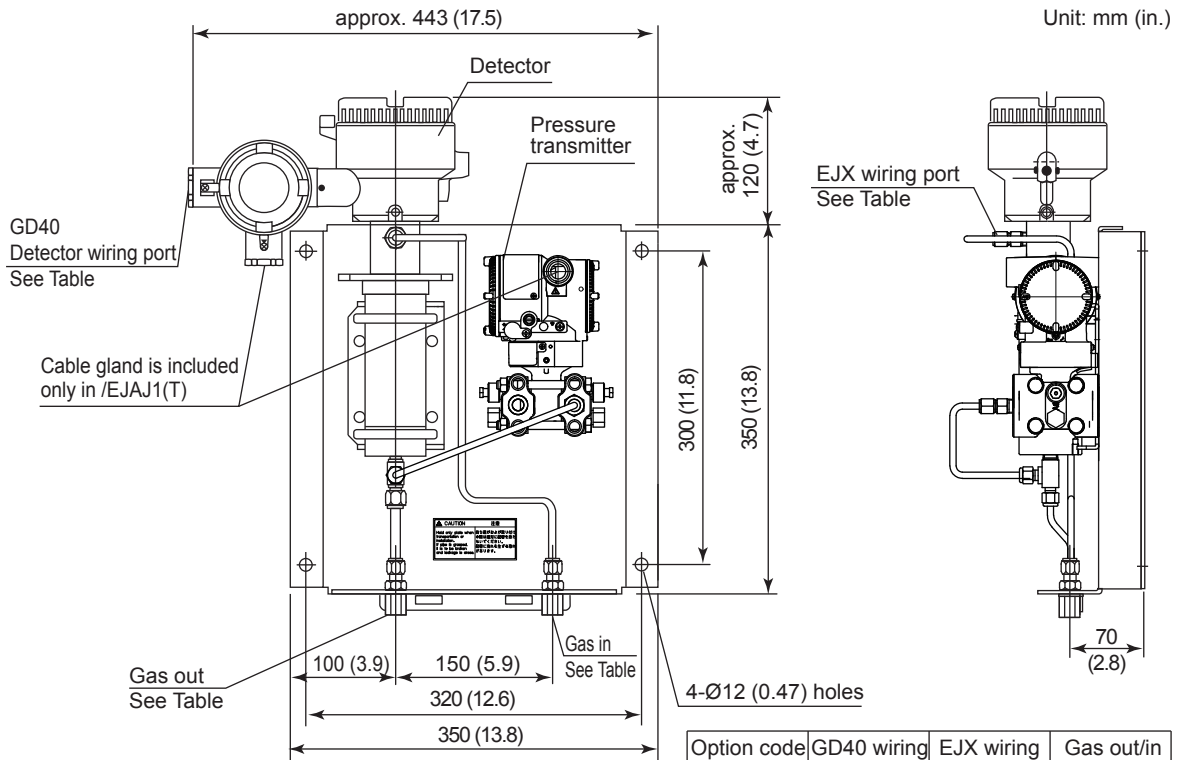

Option code	GD40 wiring	EJX wiring	Gas out/in
/EJAJ1(T)	G1/2	G1/2	Rc1/4
/EJAF2(T)	1/2NPT	1/2NPT	1/4NPT
/EJAF3(T)	1/2NPT	1/2NPT	1/4NPT
/EJAF4(T)	1/2NPT	1/2NPT	1/4NPT

1.3.5 Detector Unit (Intrinsically Safe, Explosion-proof)

- Bracket for Pipe Mounting : GD40□

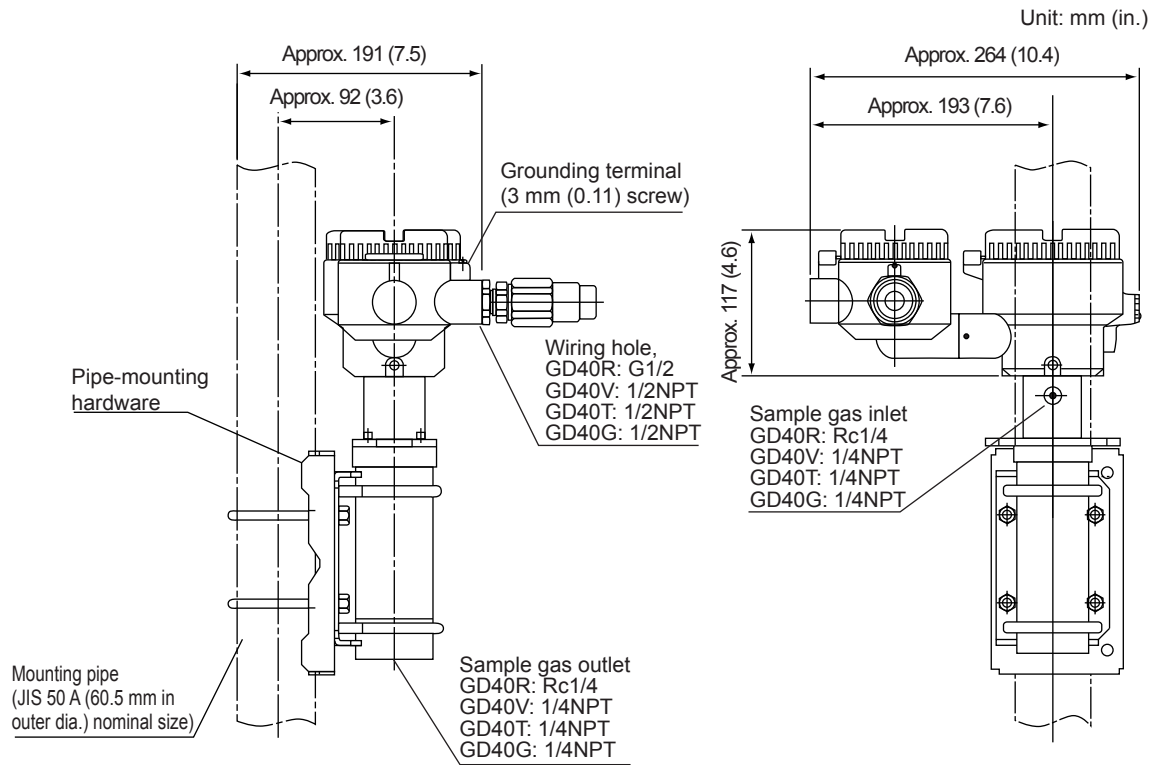

Blank Page

2. INSTALLATION, WIRING AND PIPING

The GD402 Gas Density Meter is thoroughly inspected at the factory and carefully packed to ensure the equipment does not suffer any damage during transportation. The package should also be handled with care when unpacking to prevent the equipment from undergoing severe mechanical shock. After unpacking, visually check the equipment to ensure that it is free from any damage.

Although the detector has no controls on it, it may need to be accessed for inspection or for other reasons. Install the detector in a location as close as possible to where the gas is sampled and where maintenance can be easily carried out. The converter has a display with controls on it; thus, you should install it so that the keys are positioned directly in front of you when working.

Note that there must be a clearance of at least 400 mm at the back of the converter GD402G, GD402T, GD402V and GD402R since cables are wired to the back by removing the screwed rear cover.

2.1 Installing the Detector

The GD40□ detector is an explosion-proof with intrinsically safe sensor instrument. Install the detector in a location where the following conditions are satisfied.

2.1.1 Selecting the Location

- **Explosion-proof construction**

Before installing the detector in an explosion-hazardous area, ensure that the area conforms to the explosion-proof code noted above.

- **No corrosive gases**

Corrosive gases are not desirable because they may damage the electrical components in the detector.

- **Slight mechanical vibration**

Although the detector is vibration-resistant, vibration may loosen the connections of the external wiring.

- **No exposure to direct sunlight**

Exposure to direct sunlight may raise the temperature in the detector to abnormal levels, and should therefore be avoided. Note that such abnormal temperature levels can also result from heat irradiated from high-temperature equipment around the detector.

- **Humidity maintained between 5% and 95%RH**

Avoid choosing a location that is likely to be exposed to abnormally high or low humidity over a prolonged period. It is recommended that the detector be used at a humidity between 25% and 85 % RH.

- **No exposure to rain water**

Even though the detector is rainproof, whenever possible install it where it is protected from water splashes. The reasoning for this is that the detector cover may need to be removed for maintenance or for other reasons.

- **Altitude of installation site is lower than 2,000 m.**

2.1.2 GD40T (FM Explosion-proof and Intrinsically Safe Approval)

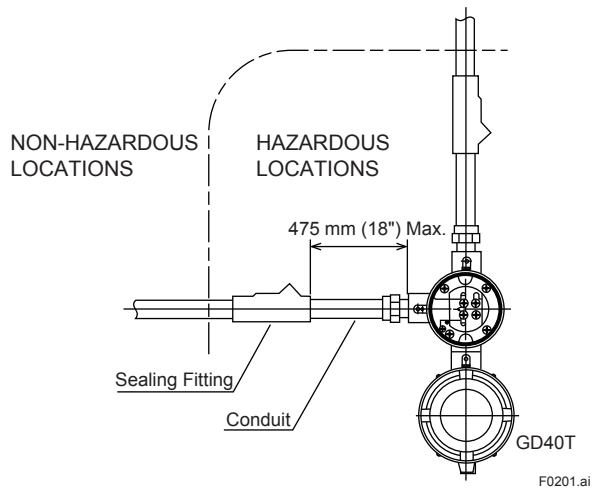

Figure 2.1

1. GD40T Gas density detector for use in hazardous (classified) locations:

- Explosion-proof for Class I, Division 1, Groups B, C and D;
Dust Ignition-proof for Class II, III, Division 1, Groups E, F and G with Intrinsically Safe sensor for Class I, II, III, Division 1, Groups B, C, D, E, F and G.
- Enclosure Rating: NEMA 4X
- Temperature Code: T5
- Ambient Temperature: -10 to 60°C

2. Wiring

- All wiring shall comply with National Electric Code ANSI/NAPA 70 and Local Electrical Codes.



WARNING

Seal all conduits within 475 mm (18 inches). Refer to Figure 2.1.

3. Operation

- Note a warning label worded as follows.



WARNING

Open circuit before removing cover.

- Take care not to generate mechanical spark when access to the instrument and peripheral devices in hazardous locations.

4. Maintenance and Repair

- The instrument modification or parts replacement by other than authorized representative of Yokogawa Electric Corporation is prohibited and will void the approval of Factory Mutual Research Corporation.

2.1.3 GD40V (CSA Explosion-proof and Intrinsically Safe Approval)

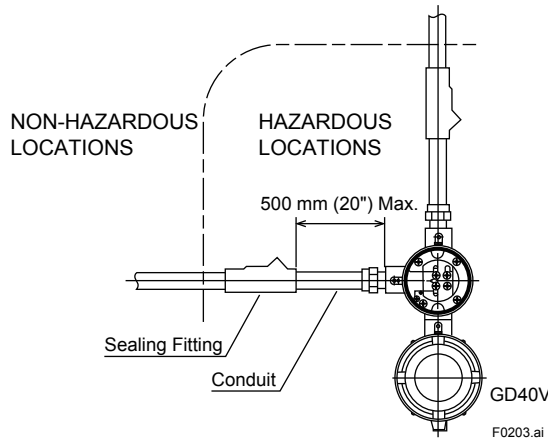

Figure 2.2

1. GD40V Gas density detector for use in hazardous (classified) locations:

- Explosion-proof for Class I, Division 1, Groups B, C and D;
Dust Ignition-proof for Class II, III, Division 1, Groups E, F and G with Intrinsically Safe sensor for Class I, II, III, Division 1, Groups B, C, D, E, F and G.
- Enclosure Rating: Type 4X
- Temperature Code: T5
- Ambient Temperature: -10 to 60°C

2. Wiring

- All wiring shall comply with Canadian Electrical and Local Electrical codes.
- Note a warning label worded as follows.



WARNING

A seal shall be installed within 500 mm (20 inches) of the enclosure. Refer to Figure 2.2.

3. Operation

- Note a warning label worded as follows.



WARNING

- Open circuit before removing cover.
- Substitution of components may impair intrinsic safety.

- Take care not to generate mechanical spark when access to the instrument and peripheral devices in hazardous locations.

4. Maintenance and Repair

- The instrument modification or parts replacement by other than authorized representative of Yokogawa Electric Corporation is prohibited and will void the certification of CSA International.

2.1.4 Mounting the Detector

The detector is designed for pipe mounting.

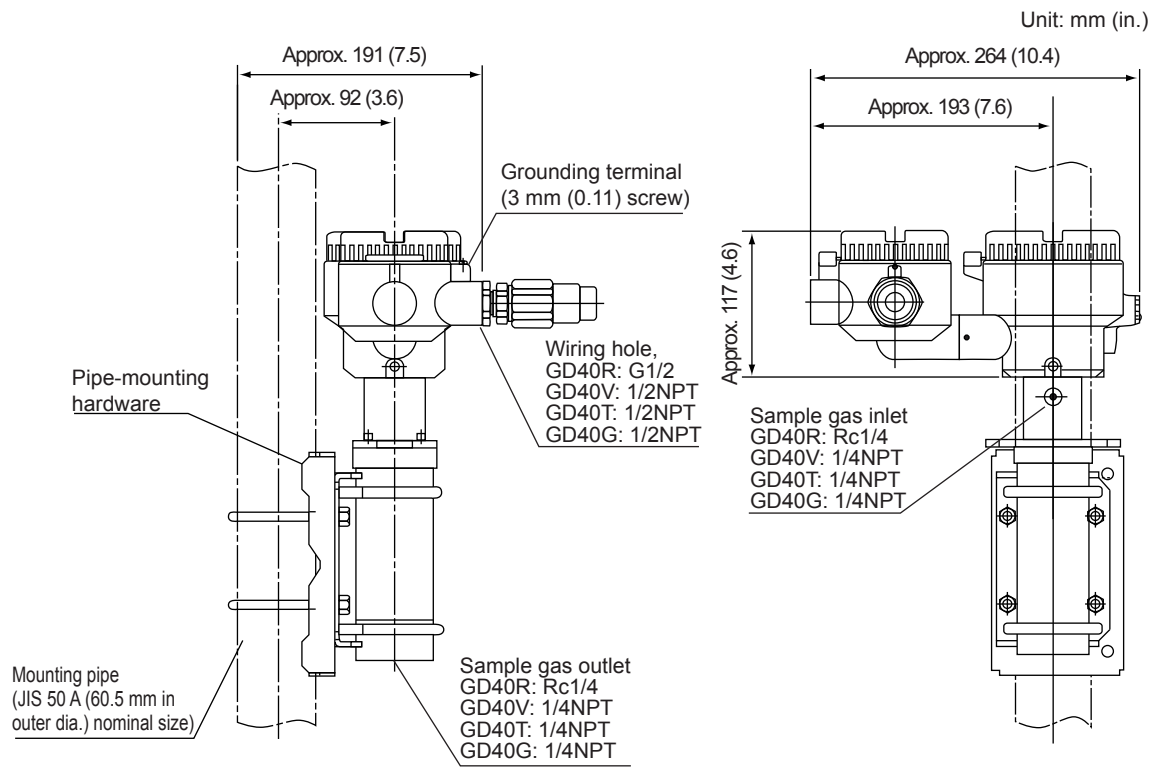

Note: Cable gland is included only in GD40R.

Figure 2.3 Vertical Mounting

2.2 Installing the Converter

The GD402 converter comes in either the non-explosion protected Model GD402G or explosion-protected Model GD402T, V, R (explosion-protection code: Refer to 1.1.1). Choose the Model GD402T or V or R if the converter is to be used in a hazardous area.

2.2.1 Selecting the Location

- **Ease of operation**

Select a location where you can easily view the readings on the display and work with the keys. Installing the converter closer to the detector will ease your maintenance work, including calibration.

- **Explosion-proof construction**

When installing the converter in an explosion-hazardous area, ensure that the area conforms to the explosion-proof code noted above.

- **No corrosive gases**

Corrosive gases are not desirable because they may damage the electrical components in the converter.

- **Slight mechanical vibration**

Although the converter is vibration-resistant, vibration may loosen the connections of the external wiring.

- **No exposure to direct sunlight**

Exposure to direct sunlight may raise the temperature in the converter to abnormal levels, and should therefore be avoided. Note that such abnormal temperature levels can also result from heat irradiated from high-temperature equipment around the converter. If the converter is likely to receive direct sunlight and the temperature in the converter will likely exceed the operating limits, attach a hood (optional).

- **Humidity maintained between 5% and 95%RH.**

Avoid choosing a location that is likely to be exposed to abnormally high or low humidity over a prolonged period. It is recommended that the converter be used at a humidity between 25% and 85%RH.

- **No exposure to rainwater**

Even though the converter is rainproof, whenever possible install it where it is protected from water splashes. The reasoning for this is that the converter cover may need to be removed for maintenance or for other reasons

- **Altitude of installation site is lower than 2,000 m.**

2.2.2 GD402T (FM Explosion-proof Approval)

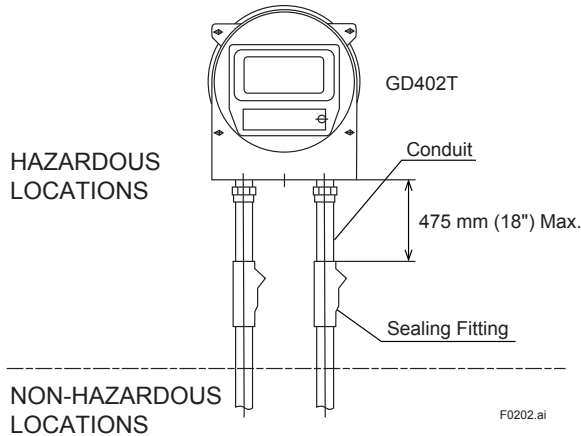

Figure 2.4

1. GD402T Gas density converter for use in hazardous (classified) locations:

- Explosion-proof for Class I, Division 1, Groups B, C and D;
Dust Ignition-proof for Class II, III, Division 1, Groups E, F and G
- Enclosure Rating: NEMA 4X
- Temperature Code: T6
- Ambient Temperature: -10 to 55°C

2. Wiring

- All wiring shall comply with National Electrical Code ANSI/NFPA 70 and Local Electrical Codes.



WARNING

Seal all conduits within 475 mm (18 inches). Refer to Figure 2.4.

3. Operation

- Note a warning label worded as follows.



WARNING

Open circuit before removing cover.

- Take care not to generate mechanical spark when access to the instrument and peripheral devices in hazardous locations.

4. Maintenance and Repair

- The instrument modification or parts replacement by other than authorized representative of Yokogawa Electric Corporation is prohibited and will void the approval of Factory Mutual Research Corporation.

2.2.3 GD402V (CSA Explosion-proof Approval)

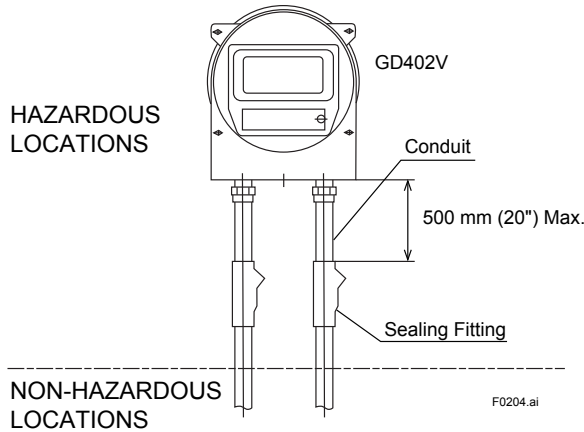

Figure 2.5

1. GD402V Gas density converter for use in hazardous (classified) locations:

- Explosion-proof for Class I, Division 1, Groups B, C and D;
Dust Ignition-proof for Class II, III, Division 1, Groups E, F and G
- Enclosure Rating: Type 4X
- Temperature Code: T6
- Ambient Temperature: -10 to 55°C

2. Wiring

- All wiring shall comply with Canadian Electrical Code and Local Electrical Codes.
- Seal all conduits within 500 mm of the enclosure. Refer to Figure 2.5.
- Note a warning label worded as follows.



WARNING

A seal shall be installed within 500 mm (20 inches) of the enclosure.

3. Operation

- Note a warning label worded as follows.



WARNING

Open circuit before removing cover.

- Take care not to generate mechanical spark when access to the instrument and peripheral devices in hazardous locations.

4. Maintenance and Repair

- The instrument modification or parts replacement by other than authorized representative of Yokogawa Electric Corporation is prohibited and will void the certification of CSA International.

2.2.4 Mounting the Converter

(1) Mounting the GD402G Converter

• Pipe Mounting

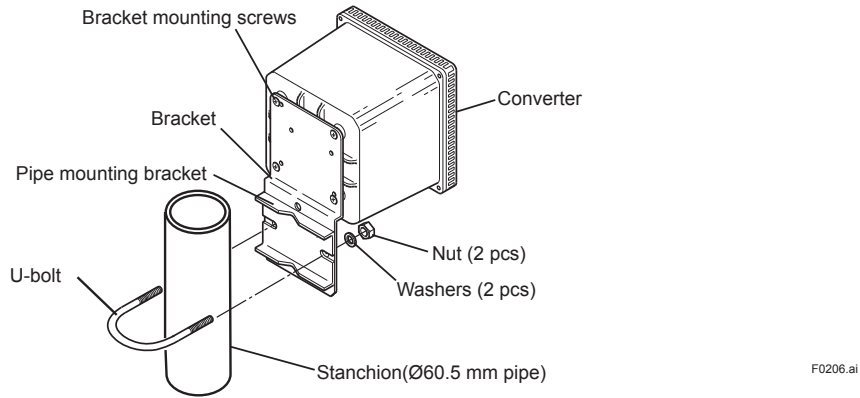
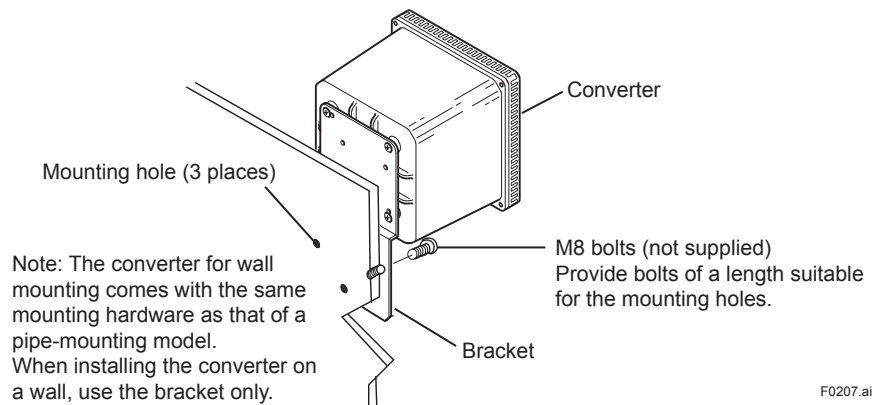

Figure 2.6 Pipe Mounting

• Wall Mounting

Figure 2.3 shows how to mount the converter on a wall.



Unit : mm

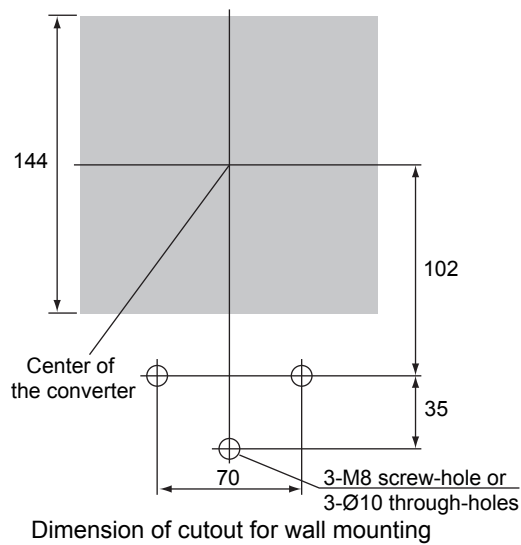

Figure 2.7 Wall Mounting

• Panel Mounting

Figure 2.4 shows how to mount the converter on a panel.

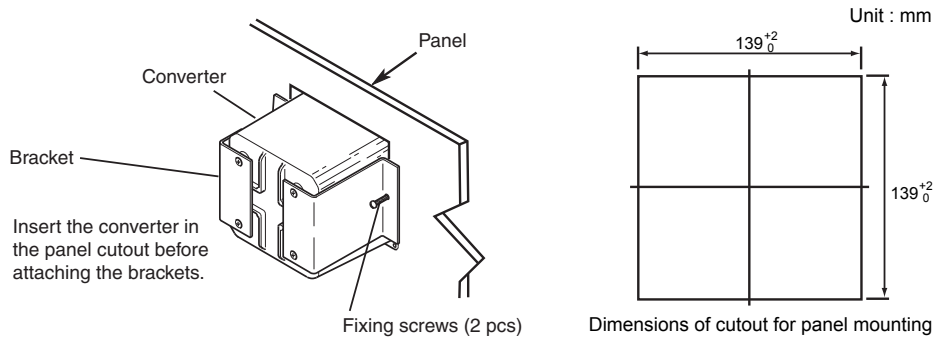

Figure 2.8 Panel Mounting

(2) Mounting the GD402T, V, R Converter

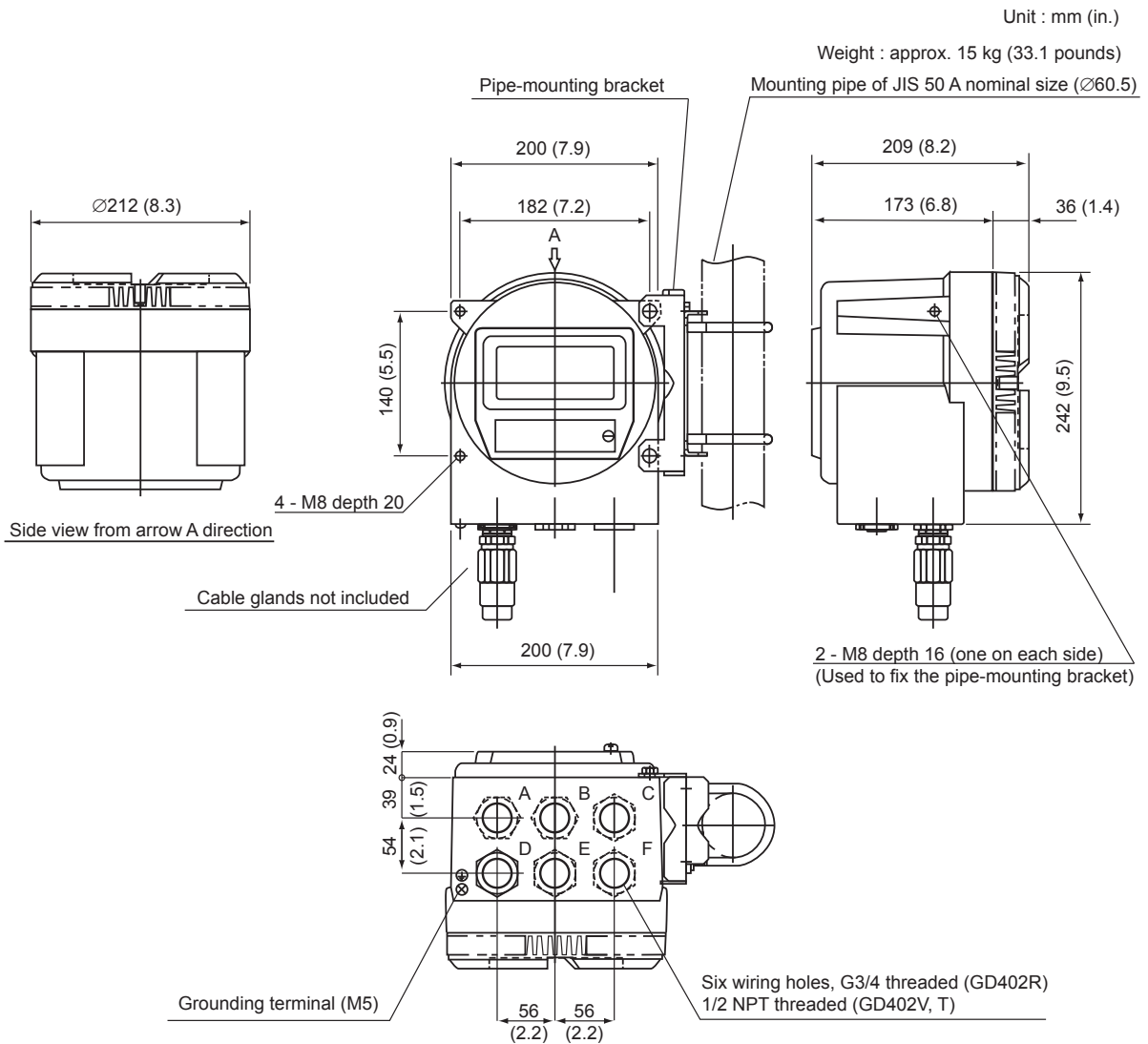

Figure 2.9 Mounting Explosion-proof Converter

2.3 Piping



CAUTION

In the case of replacement range, H₂ in CO₂ or Air in CO₂, the output happen to be fluctuated by pressure loading to detector. In order to reduce the effect, flowmeter is to be set upper side of detector so that the pressure loading to the detector is going to be about atmospheric pressure.

The piping connected to the analyzer comprises a line that feeds the gas under measurement to the detector, a line that returns (or releases to the atmosphere) the gas exhausted after measurement, and lines that carry the zero and span calibration gases. The type of piping chosen depends on the composition of the gas under measurement, its pressure, the amount of dust mixed, and the response (dead time). It is advisable however to use stainless steel piping of sizes from 6 mm and 4 mm in outer and inner diameters up to JIS 15 A (21.7mm in outer dia.).

Refer to the following instructions when connecting the analyzer piping.

- Figure 2.10, "System Configuration," shows an example of piping. Connect the lines securely to ensure that there is no gas leakage in the system.
- Make sure the pressure of the sample gas is no greater than 0.5 MPa when measured at the detector inlet. If the pressure is too high, use a pressure reducing valve to regulate the pressure to a normal level. If the pressure is too low, it must be raised using a pump.
- If the gas under measurement contains dust, mist or moisture, such impurities must be removed. Install a filter, mist separator or dehumidifier to remove these impurities from the gas.
- In order to return the gas exhausted after measurement, the difference in pressure between the detector inlet and the point of returning the gas must be 0.5 kPa minimum. Choose piping with a large inner diameter to minimize pressure loss in the return gas line.
- ALWAYS install a stop valve at the point where the gas is sampled (or returned).
- The pressure transmitter for compensating pressure is designed to detect the pressure inside the detector; install a pressure lead pipe as close to the detector as possible (preferably, no more than 0.5 m away).

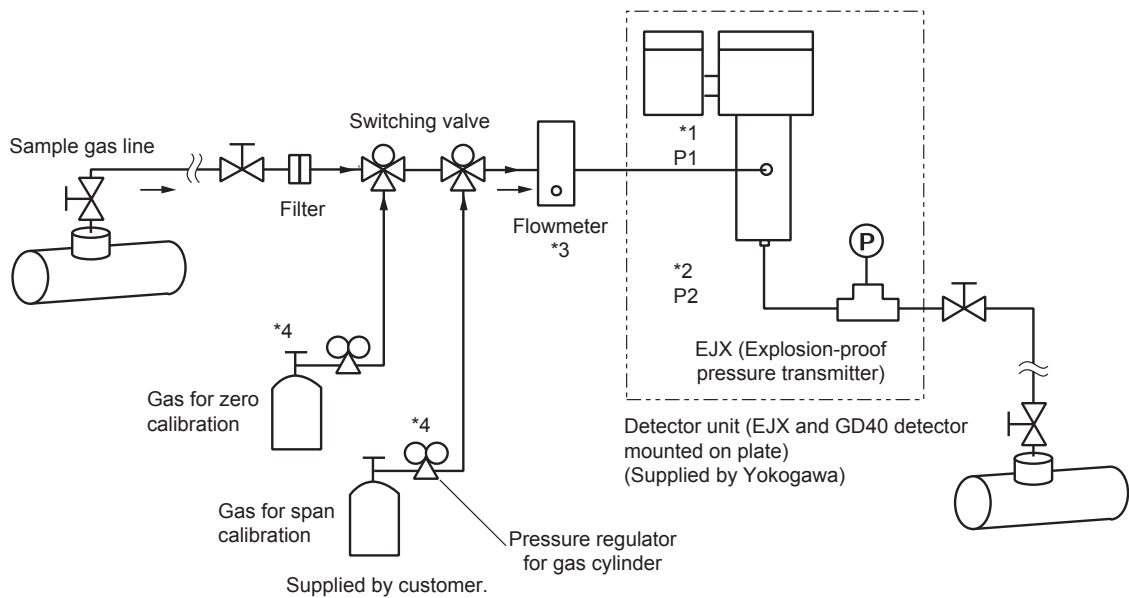

- *1: P1 (Inlet pressure) \leq Max. 0.5 MPa (71 psi)
- *2: P1 (Inlet pressure) - P2 (Outlet pressure) \geq 0.5 kPa (0.071 psi) (depending on the size and length of the pipe)
- *3: Flowrate = 0.1 to 1 L/min
- *4: The cylinder pressure must be reduced to P1 (Inlet pressure).

F0211.ai

(1) Example of Gas density and Calorie meters

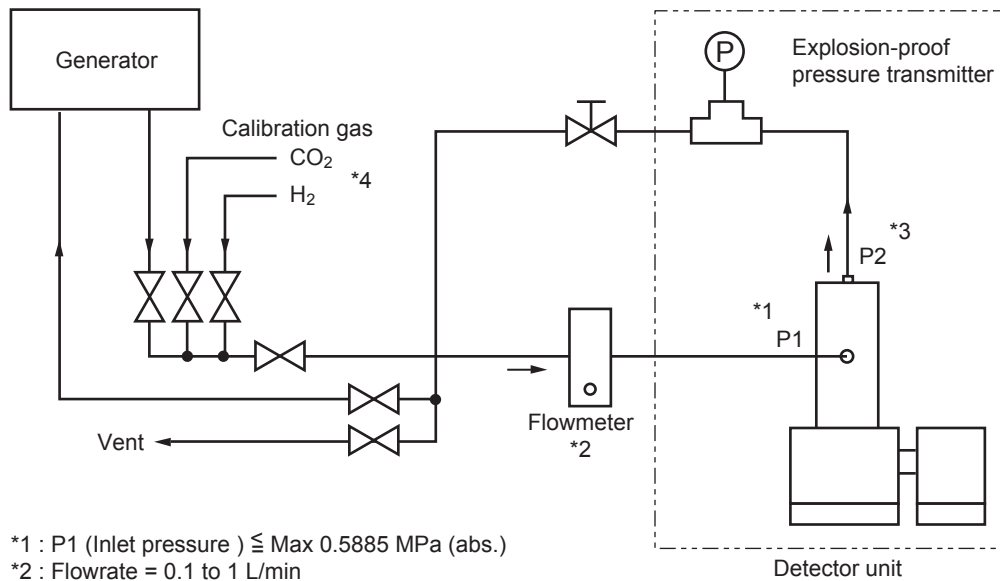

- *1 : P1 (Inlet pressure) \leq Max 0.5885 MPa (abs.)
- *2 : Flowrate = 0.1 to 1 L/min
- *3 : P1 (Input pressure) - P2 (Output pressure) \geq 0.5 kPa
- *4 : The cylinder pressure must be reduced to P1 (Inlet pressure).

F0212.ai

(2) Example of Hydrogen purity/Replacement meter System Configuration

Figure 2.10

2.4 Wiring



WARNING



Danger High Voltage !

Some parts of the meter's internal assembly have high voltages. Inadvertent contact with those parts may result in electrical shock or injury. ALWAYS turn off the power to the meter before removing the rear or front cover by using external circuit breaker.

This section explains how to wire the GD402 Analyzers. Note that this document is limited to the basic system configuration only (detector, converter and pressure transmitter). For details on the wiring of instruments used to receive analog output signals or contact output signals, see their respective instruction manuals.



CAUTION

The GD402 gas density meter is shipped after adjusting the both of detector and converter in pairs. When installation, confirm whether the serial number on both of converter and detector are in pairs or not. If mismatched in pairs, converter is to be out of order. When converter or detector supplied individually, enter the detector constants, described on inside the lid of the GD40, into converter so that the GD402 is going to be well.

In detail, please refer to Figure 5.30, Figure 6.31 or Figure 7.28.



CAUTION

After wiring to the terminal block, do not push the remaining cables into the enclosure.

2.4.1 Wiring Procedure

- (1) The types of cables wired to the GD402 Analyzers are:
 - Cable wired to power supply
 - Cable wired to detector input
 - Cables wired to output signals (two) -- or one signal if BRAIN communication is used
 - Cables wired to contact outputs (five) -- provided as necessary
 - Cable wired to contact input -- provided as necessary
 - Cables wired to pressure transmitter
 - Cables wired to the ground
- (2) The GD402 converter has six cable inlets for external wiring. Wire the converter through cable glands. As a rule, choose cable glands as shown in Figure 2.11.

<GD402G>

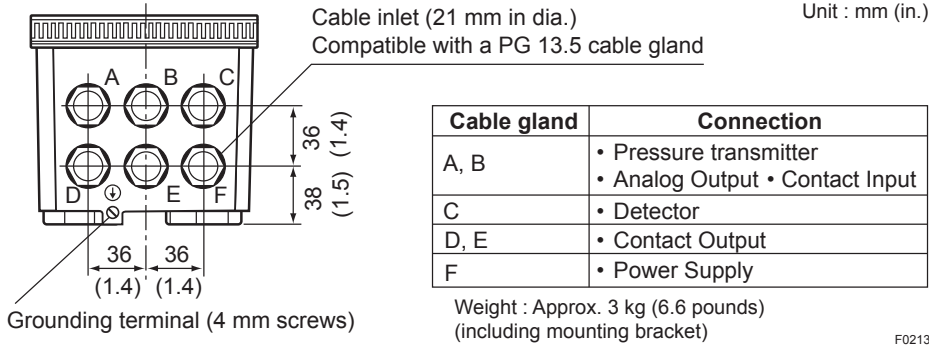

<GD402T, V, R>

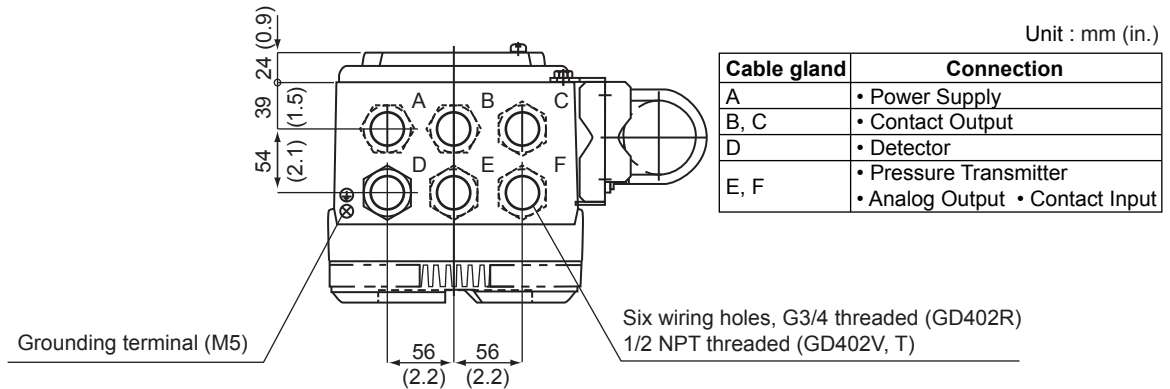

(3) The following explains the general wiring procedure for each type of converter.

<Wiring the GD402T, V, R converter>

! WARNING

Cables that withstand temperatures of the least 75°C should be used for wiring.

! CAUTION

The rear cover and the metal plugs at the external-wiring connections are fixed onto the converter case with hex setscrews. Before removing the cover, be SURE to loosen the setscrews. If you rotate the cover or a plug without loosening the setscrews, their threads may be severed, making the cover unremovable.

When the rear cover or any of the cable glands or plugs are removed, handle them with utmost care so that the threads are not damaged. When re-attaching it on to the converter, clean the threads so they will not be damaged due to such foreign matters as dust.

- Loosen the setscrews and remove the rear cover by rotating it counterclockwise.
- Guide the required external-wiring cables through the cable glands to the converter.
Exercise care so as to avoid connecting them with the wrong polarities.
- After wiring, securely fasten the rear cover and cable glands.

<Wiring the GD402G converter>

- Loosen the setscrews in the four corners and remove the front cover.
- Remove the terminal cover. Guide the required external-wiring cables through the cable glands to the converter. Beware of the correct polarities.
- After wiring, reinstall the terminal cover and front cover in place.

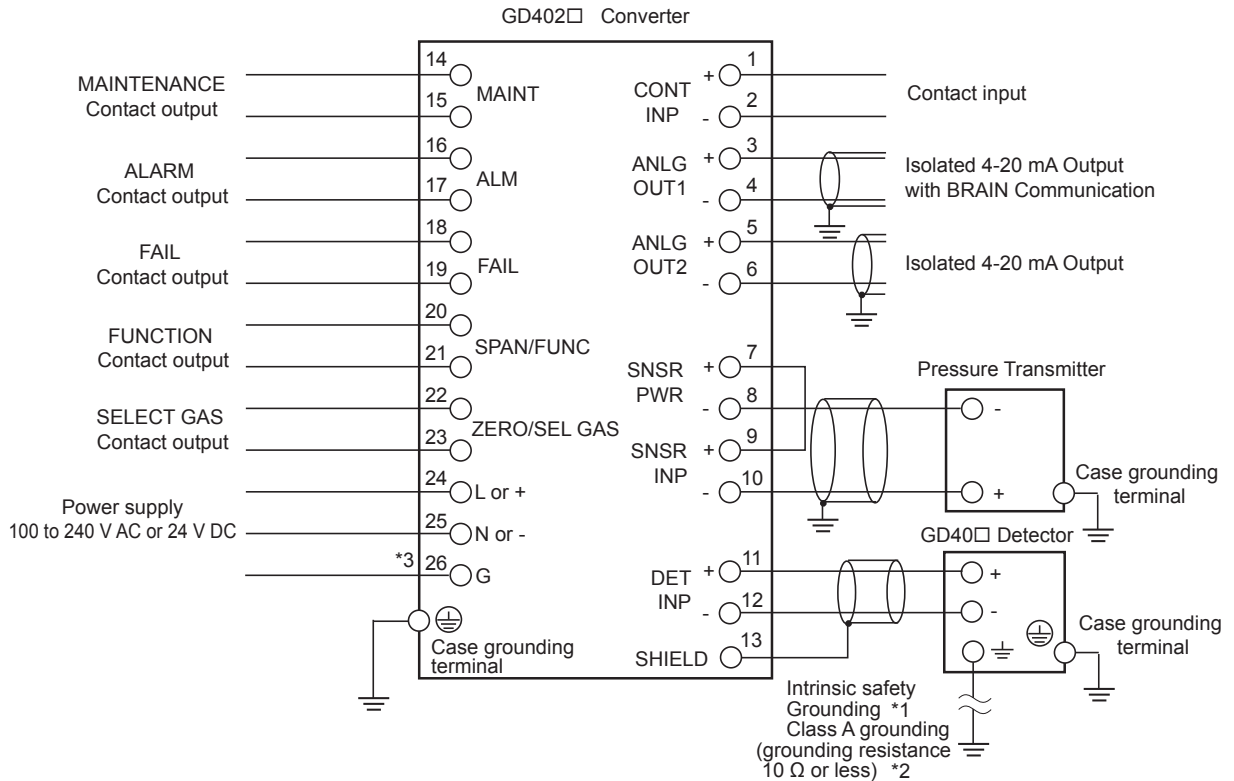

Cable List

Terminal	Indication	Shield Requirement	Requirement
MAINTENANCE Contact output	MAINT	Unshielded	
ALARM Contact output	ALM	Unshielded	
FAIL Contact output	FAIL	Unshielded	
FUNCTION Contact output	SPAN	Unshielded	
SELECT GAS Contact output	ZERO	Unshielded	
Contact input	CONT IN	UnShielded	
Analog output1	ANLG OUT1	Shielded	Total resistance should not exceed 50 Ω. Shield should be grounded at one end only. Maximum load resistance including wire resistance is 600Ω. When BRAIN communication is used, it is 250 to 550 Ω.
Analog output2	ANLG OUT2	Shielded	
Pressure transmitter input	SNSR PWR SNSR INP	Shielded	Total resistance should not exceed 50 Ω. Shield should be grounded at one end only.
Detector input	DET INP SHIELD	Shielded	Total resistance should not exceed 50 Ω. Connect shield to SHIELD terminal on converter.
Supply	L, N, G	Unshielded	

*1 Intrinsic safety grounding

GD402V, GD40V; All wiring should comply with Canadian Electrical Code and Local Electrical Codes.

GD402T, GD40T; All wiring should comply with National Electrical Code and ANSI/NFPA 70 and

Local Electrical Codes.

*2 When select GD402T/V/R.

*3 Terminal 26 is connected to the case-grounding terminal.

Figure 2.11 Terminals on the Converter

Electrical Noise Protection

If a malfunction due to noise occurs, strengthen measures against noise. For example, ground the detector body or use a double-shielded cable. If a double-shielded cable is used, ground shields of each conductor at one end. Ground one end of the outer shield on the detector side to the detector case and connect the other end on the converter side to terminal 13. See the User's Manual for more instructions on cable installation.

Contact Input Function of the Hydrogen Purity Meter

For hydrogen purity meter, the contact input is used for range selection.

Open: Concentration measurement for Air in CO₂

Close: Concentration measurement for H₂ in CO₂.

Contact Output Specifications

Indication	Specification
MAINT ALM	Contact Type: Voltage free, dry contact (mechanical relay contact output) Contact rating: 250 V AC 3 A or 30 V DC 3 A Contact arrangement: NO/NC, selectable
FAIL	Contact Type: Voltage free, dry contact (mechanical relay contact output) Contact rating: 250 V AC 3 A or 30 V DC 3 A Contact arrangement: NC, fixed
SPAN/FUNC ZERO/SEL GAS	Function contact: Use distinguish between the Hydrogen purity meter and the Replacement meter. Select gas contact: Use distinguish measuring ranges in the Replacement meter. Contact Type: Voltage free, dry contact (mechanical relay contact output) Contact rating: 250 V AC 3 A or 30 V DC 3 A Contact arrangement: NO/NC, selectable

2.4.2 Cables Wired to Power Supply

The GD402G bears the CE marking. When using the meter in a place where the CE marking is obligatory, or when performance meeting the CE marking requirements is needed, the following wiring is required. (Note that the following wiring is not required when the power supply is 24 V DC.)

- Install an external switch or circuit breaker to the power supply of the converter.
- Use an external switch or circuit breaker that is rated at 5 A and conforms to IEC 947-1 or IEC 947-3.
- Install the external switch or circuit breaker in the same room as the converter is installed.
- The external switch or circuit breaker should be installed in a location that allows operator access and should be marked a power supply switch to the converter.



CAUTION

The GD402R, T, V converter contains a power switch and a fuse. The switch cannot be operated however, if the converter is installed in an explosion-hazardous area; it must be left placed in the ON position. When Power ON/OFF, use external circuit breaker

Wiring is for supplying power supply that meets specifications to the GD402 converter. Use a 3-conductor cable with a size of 1.25 to 2.5 mm² and an outside diameter of 8 to 16 mm for 100-240 V AC type and a 2-conductor cable for 24 V DC type.

Wire the cable as instructed below:

- (1) Strip the sheath 7 mm at the cable end to be connected to the converter.
- (2) Connect the cable to terminals L, N, and G or terminals + and - on the converter.
Loosen the terminal screw, insert the stripped part of the wire into the terminal hole, and fix the cable by tightening the screw. (adequate tightening torque: 0.4 N·m)

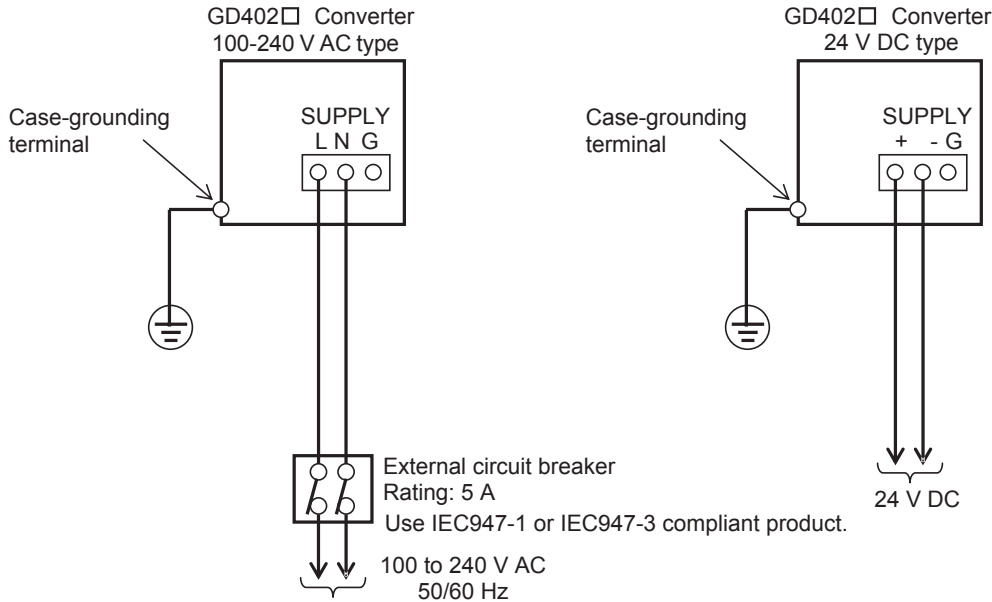

Figure 2.12 Cables Wired to Power Supply

2.4.3 Cables Wired to Outputs

These cables are used to transmit 4-20 mA DC signals and carry out BRAIN communication. Use shielded cables of 8 to 16 mm in finished outer diameter and 0.75 mm² minimum in thickness (or a two-core shielded cable for single output).

Wire the cables as instructed below:

- (1) Use cables that are 0.75 to 2.5 mm² thick. Treat the cable ends by stripping the core wires back 7 mm (see Figure 2.14).
- (2) Wire the cable for output 1 to terminals 3 and 4 on the block and the cable for output 2 to terminals 5 and 6 on the block. Beware of the correct polarities. Note that only terminals 3 and 4 (output 1) are effective for BRAIN communication. Loosen the terminal screws, insert the stripped ends of the core wires into the terminals, and fasten the screws to fix the cables.
- (3) Ground the shielding wire at a given terminal on the converter; do not ground the other end of the cable. (The appropriate tightening torque for the internal wiring terminals is 0.4 N·m.)

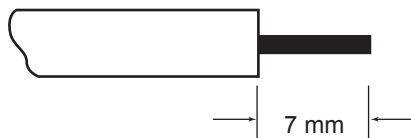

F0217.ai

Figure 2.13 Examples of Treatment on Cable End Wired to the Converter

2.4.4 Cables Wired to Contact I/Os

The contact I/Os of the GD402 converter comprise the start-of-calibration contact (input), the FAIL, ALARM and MAINTENANCE contacts, and the contacts for operating the solenoid valves for span and zero calibrations. Choose the type of cables for a group of calibration-purpose contacts and for a group of other contacts separately.

For wiring to the calibration contact output, use a cable of 8 to 16 mm in finished outer diameter and 1.25 mm² minimum in thickness. For wiring to other contacts, use a cable of 8 to 16 mm in finished outer diameter and 0.13 to 1.25 mm² in thickness, while choosing the number of core wires depending on the number of contacts used.

Since the contact outputs are voltage-free, driving such devices as alarm lamps requires a separate power supply. For the contact input (start of calibration), provide a no-voltage signal. (Do not apply an external voltage.)

Wire the cables as instructed below:

- (1) Use cables 0.13 to 1.25 mm² thick. Treat the cable ends by stripping back the core wires to 7 mm from the end (see Figure 2.14).
- (2) Wire the cables to their respective given terminals on the block, being careful not to mistake one terminal for another. For terminal numbers assigned to the respective contacts I/Os, see Figure 2.12.

Loosen the terminal screws, insert the stripped ends of the core wires into the terminals, and fasten the screws to fix the cables. (The appropriate tightening torque is 0.4 N·m)

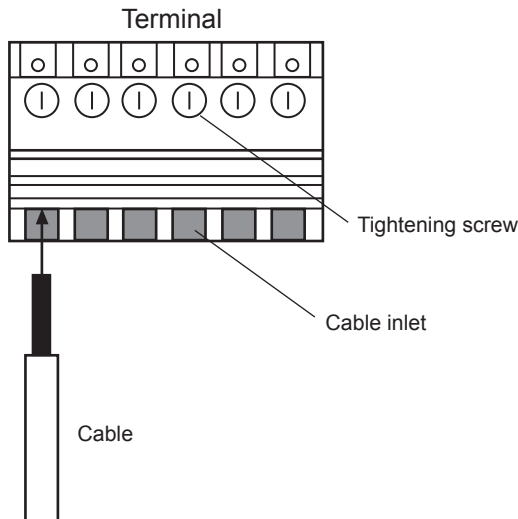

F0218.ai

Figure 2.14 Connection between terminal and cable

2.4.5 Cable Wired to GD40□ Detector

The cable wired to the GD40□ detector comes from the GD402 converter. Use a shielded cable of 10 to 13.5 mm in finished outer diameter that suits the dedicated cable gland. Wire the cable through the cable gland, being careful not to connect the cable with the wrong polarities. Attach M4 crimp terminals to the ends of the core wires (see Figure 2.14). Connect the shielding wire to terminal 13 on the converter (see Figure 2.12). When crimping the terminals, use tools that fit the terminals.

If a malfunction occurs and it is assumed to be due to noise, use a double-shielded cable (for example, the cable with Yokogawa’s Model GDW-L□ □ □). Connect the outer shielding wire to terminal 13 on the converter and the other end of the wire to the grounding terminal on the detector. Connect the inner shielding wires to the grounding terminal on the converter (see Figure 2.17).

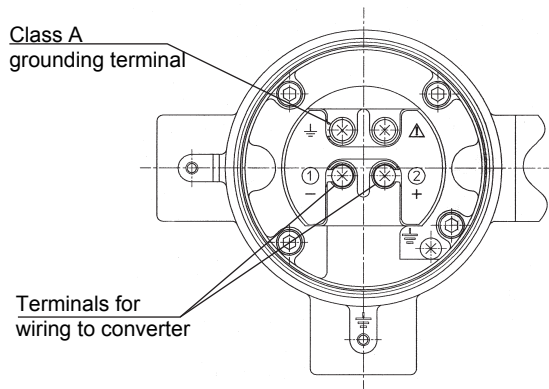

F0219.ai

Figure 2.15 Configuration of Detector Terminals

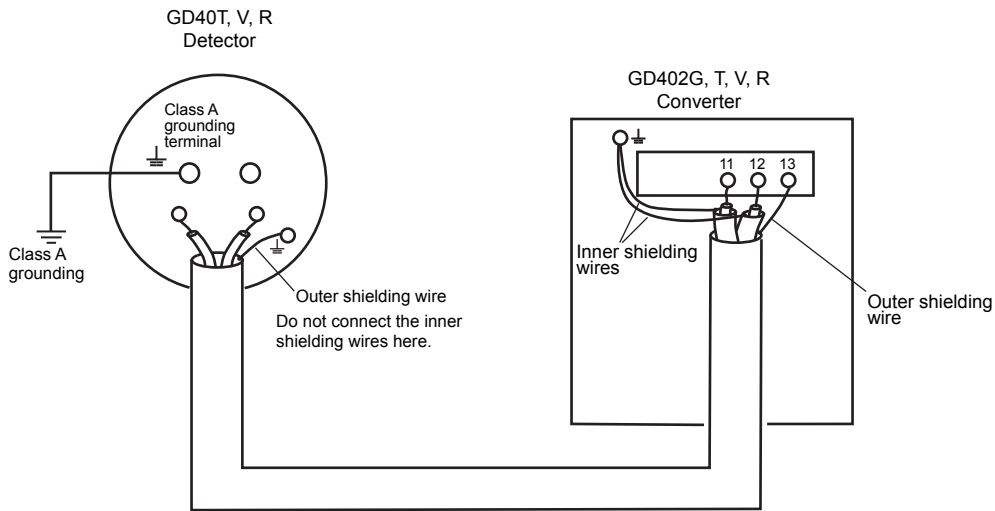

F0220.ai

Figure 2.16 Connection Between Detector and Converter When Using a Double-Shielded Cable

2.4.6 Wiring to Model EJX310A pressure transmitter

When Wiring to model EJX310A pressure transmitter, connect by using cables from GD420□ converter. Wire the cables through cable glands. Be sure not to misconnect polar. For finished external diameter, refer to Figure 2.11, "Terminals on the Converter."

The size of the terminal screw threads is M4. Use a crimp terminal suited for your cable terminal.

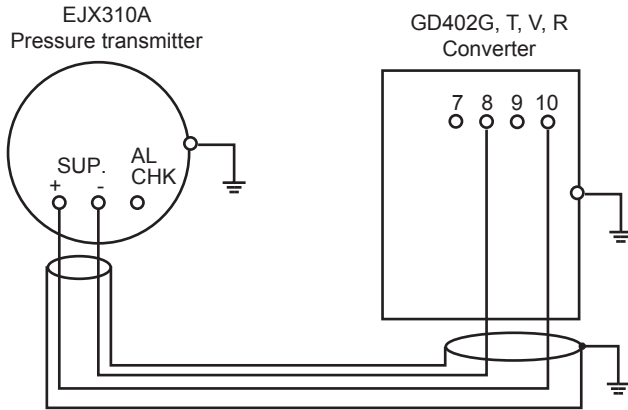

Figure 2.17 Connection Between Detector and Pressure Transmitter

For wiring and grounding of the pressure transmitter, refer to the user’s manual attached to the pressure transmitter.

2.4.7 Cables Wired to the Ground

When using the GD40R detector in an area requiring explosion protection, BE SURE to ground it as per the Class A Grounding Standard using a conductor of at least 2 mm² in nominal thickness. Also BE SURE to ground the GD402□ converter as per the Class D Grounding Standard.

In the case of using GD40T detector, Intrinsically Safe Grounding shall comply with National Electrical Code ANSI / NFPA 70 and Local Electrical Codes.

In the case of using GD40V detector, Intrinsically Safe Grounding shall comply with Canadian Electrical Code and Local Electrical Codes.

Use No. 26 internal wiring terminals or the grounding terminals of the converter. (The appropriate tightening torque for the internal wiring terminals is 0.4 N·m). Case-grounding terminal can be used as protective ground terminal. When using the detector’s grounding terminals, attach M4 crimp terminals to the ends of the grounding cables. When crimping the terminals, use tools that fit the terminals.

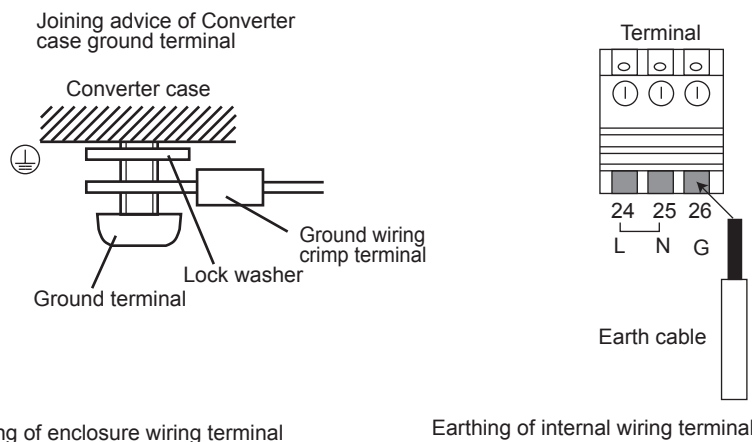

Figure 2.18 Power and Ground Wiring

3. OPERATION

This chapter explains how to operate the GD402 Analyzers.

3.1 Preparation for Operation



WARNING

- DO NOT supply power to the analyzer when inspecting it.
 - Leave the power switch which is built in the converter, in the ON position.
 - DO NOT open the terminal box cover with the power turned on, if the analyzer is installed in an explosion-hazardous area.
 - When using the converter under high ambient temperatures, be careful as the metal parts of the converter will also be hot.
-

3.1.1 Inspecting Installation, Piping and Wiring Workmanship

Before turning the power on, inspect workmanship with regards to installation, piping and wiring as instructed below:

- Examine how the GD402 analyzer and its peripheral equipment are installed.
- Check the sample-gas line, which feeds the GD40□ detector, for any gas leakage.
- Inspect the system to ensure that the GD402 analyzer and its peripheral equipment are wired correctly. After inspection, shut the terminal box cover securely.
- Place the power switch built in the GD402T, GD402V, GD402R converter (explosion-protected) in the ON position.

3.1.2 Supplying Power

First make sure that when the GD402 analyzer is turned on, no control instruments connected to the analyzer will come into operation by the signals transmitted from the analyzer. Next, turn on the external power switch to start the analyzer. At that point, make sure the internal power switch is in the ON position if the converter is an explosion-protected model.

After power-on, the analyzer will begin to operate in the measurement mode.

[Major Items Shown in Measurement Mode]

- **Measured Values**

In the Message selection under the DISP mode, choose the item you want to show.

Item	No. of Digits and Position of Decimal Point	Message
Physical density	XX.XXXX	KG/M3
Physical density	X.XXXXX	LB/FT3
Compensated density	X.XXXX	KG/M3
Compensated density	X.XXXXX	LB/FT3
Calorific value	XXX.XXX	MJ/M3
Calorific value	X.XXXX	KBTU
Specific gravity	X.XXXX	SP GR
Molecular weight	XXX.XX	MOL
Concentration	XXX.X	VOL%

- **Types of Messages**

- Measurement units
- Error number (shown if an error occurs)
- Alarm number (shown if an alarm occurs)

- **HOLD and FAIL Indications (shown regardless of whether the analyzer is in the measurement mode or not)**

- HOLD appears when the analyzer is in a hold state.
- FAIL appears if an error occurs.

3.1.3 Display on Operation Panel and Operation Keys

Figures 3.1 and 3.2 illustrate the operation panels of the Model GD402G and GD402T, GD402V, GD402R converters, respectively. The operation panel has a display and operation keys. Use the seven operation keys on the panel to set operation parameters, and so on.

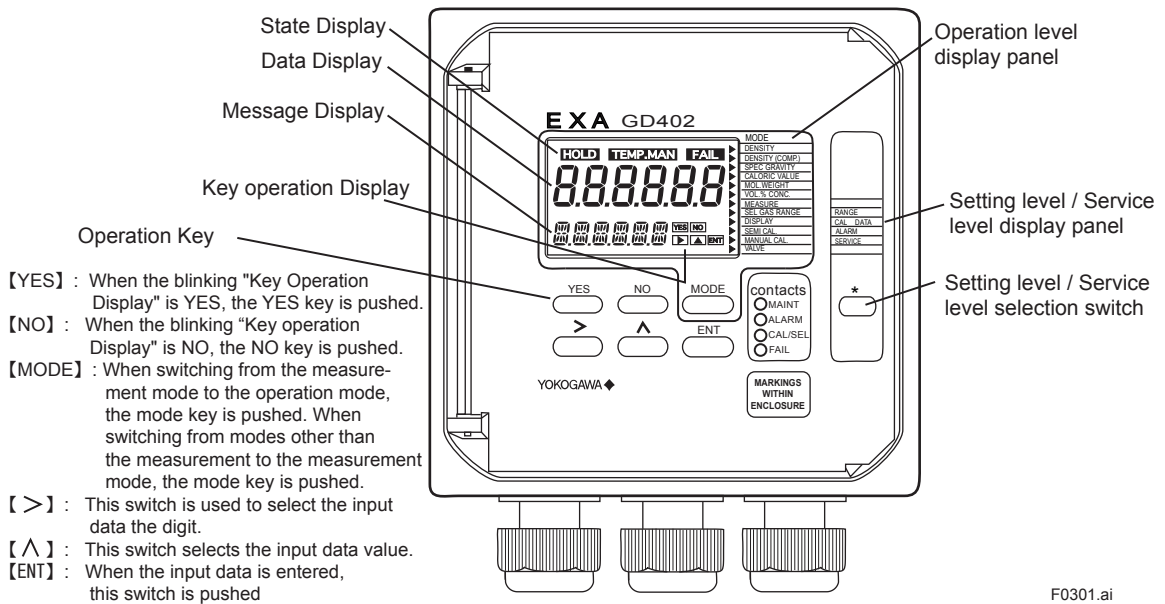

Figure 3.1 Functional Description of GD402G Converter (Cover Open)

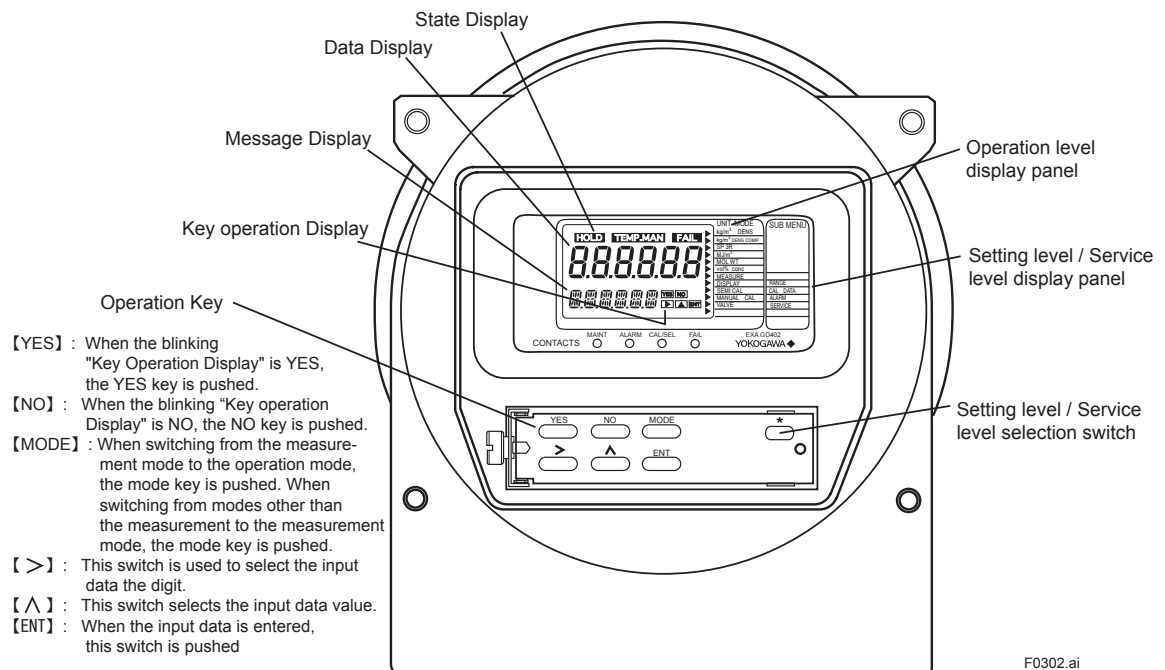

Figure 3.2 Functional Description of GD402T, GD402V, GD402R Converter (Cover Open)

3.1.4 Basic Key Operation

The basics of key operation are the selection between modes/levels, the selection and execution of the function/action, and entry of data values.

1. Selecting Between Modes at the Operation Level (See Chapter 5, 6 or 7 for details.)

- You can enter the measurement mode by pressing the [MODE] key while the analyzer is in a mode other than the measurement mode.

When switching between modes, note the following two points:

- Press the [MODE] key once. The message field first shows "DISP" in Figure 3.3-(1) (then password is not selected in first condition). And then changes to look like one shown in Figure 3.3-(2).

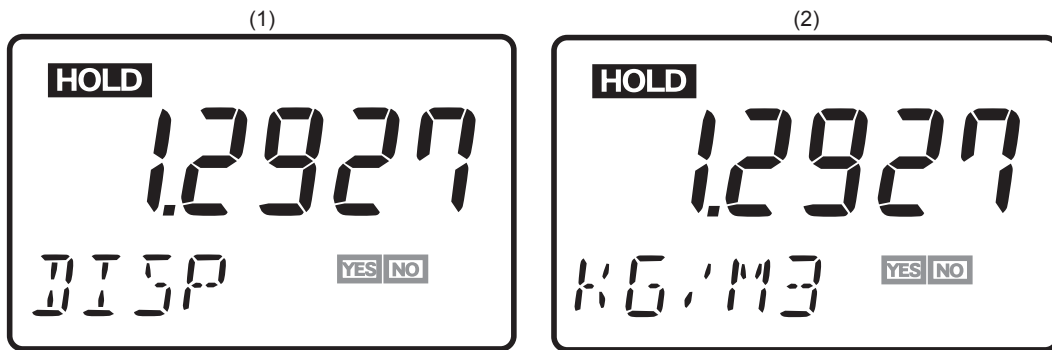

When password is selected, the message field <*PASSW>, prompting you to enter a passwords. Type [XXX] and press the [ENT] key. The message field changes to look like one shown left.

In the display shown left, the [YES] and [NO] fields blink. Pressing the [YES] key will change the message to [KG/M3], indicating the analyzer is now in the density mode.

F0303.ai

Figure 3.3 Examples of Display at Operation Level (In case of the Density Meter)

- In the display shown in Figure 3.3-(1), each press of the [NO] key changes the message field, enabling you to choose a different mode by its indication.

2. Selecting Between Modes at the Setting Level (See Chapter 5, 6 or 7 for details.)

- In the measurement mode, press the [*] key (to select between settings).

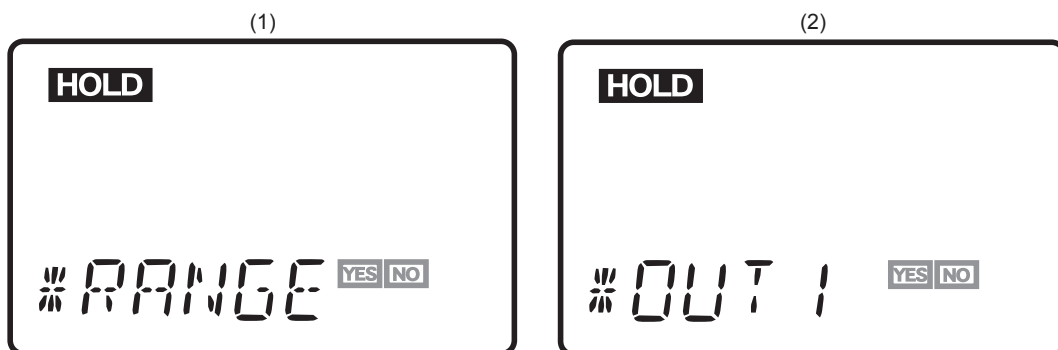

When password is selected, the message field shows <*PASSW>, prompting you to enter a passwords. Type [XXX] and press the [ENT] key. The message field changes to look like one shown left.

In the display shown left, the [YES] and [NO] fields blink. Pressing the [YES] key will change the message to read [OUT1], indicating the analyzer is now in the analog output setting mode.

F0304.ai

Figure 3.4 Examples of Display at Setting Level

- In the display shown in 3.4-(1), each press of the [NO] key changes the message field, enabling you to choose a different mode by its indication.

3. Entering Data Values

NOTE

The data you have entered keep in memory even if you turn off the power. If the data you have entered are provisional, reenter the normal data.

The following explains how to make changes to existing data entries.

In the display shown in Figure 3.4-(2), pressing the [YES] key causes the message field to default to [*DENS]. Pressing the [YES] key once again changes the message to [*Z_DNS], the range of lower limit setting, and makes the indication of the lower limit blink.

Assume the existing data entry of the range's lower limit is 1.2927. To change the value to 2.0535, follow the instructions given below:

- (1) Press the [>] key so "1" starts blinking.
- (2) Press the [^] key until the blinking "1" changes to "2".
- (3) Press the [>] key until the next digit begins blinking. Then, press the [^] key until the blinking "2" digit changes to "0".
- (4) Press the [>] key until the next digit begins blinking. Then, press the [^] key until the blinking digit changes to "5".
- (5) Press the [>] key until the next digit begins blinking. Then, press the [^] key until the blinking digit changes to "3".
- (6) Press the [>] key until the next digit begins blinking. Then, press the [^] key until the blinking digit changes to "5".
- (7) Press the [ENT] key. This confirms the value "2.0535".

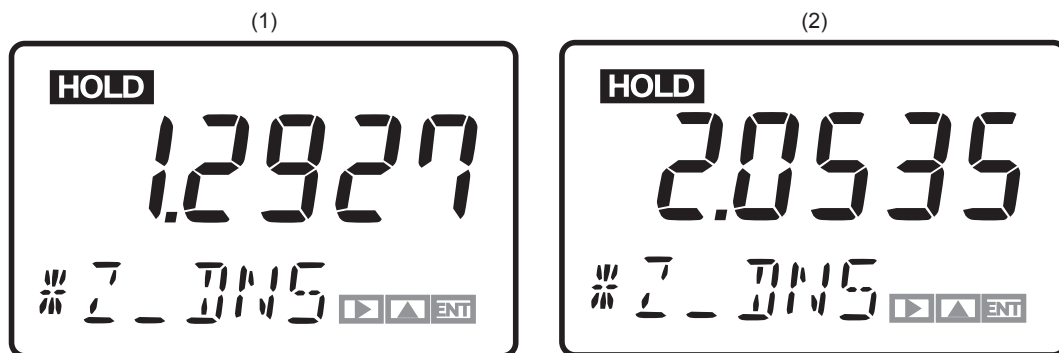

In the display shown in Figure 3.4 (2), pressing the [YES] key will change the display to look like this.

Pressing the [ENT] key enters the value shown in the data field.

F0305.ai

Figure 3.5 Display During Data Setting

4. Entering a Password

If you need, a password can be entered to proceed into the operation, setting or service level. When you attempt to enter that level, a password-entry message (password prompt) like one shown in Figure 3.6-(1) appears. The required password is “XXX”. (See section “4.2 Setting Lists”.)

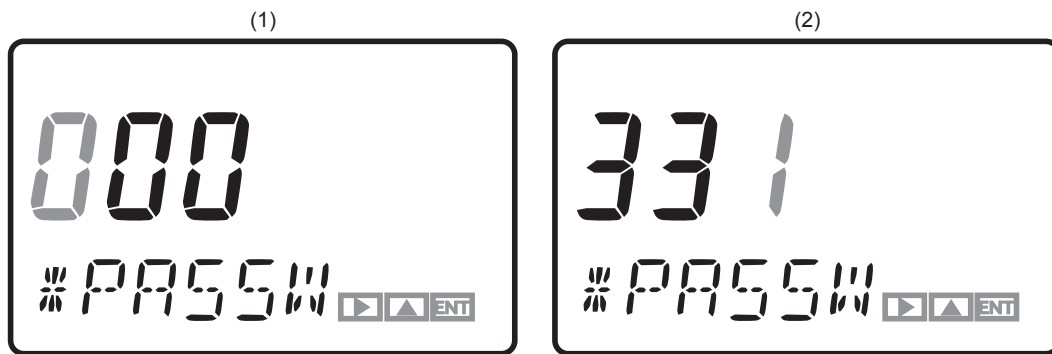

When password is selected, pressing the [MODE] key, then the [*] key, changes the display to look like this.

Type the password (XXX) and then press the [ENT] key. If you type a wrong password, you cannot enter the level.

F0306.ai

Figure 3.6 Password Prompt and the Reading of a Password Typed

3.1.5 Checking the Setting Parameters

Set up the relevant parameters, display unit, analog output and others, to meet individual operating requirements. The GD402 gas density meter is designed to change into density, calorific meter and hydrogen purity meter according to application. (Select “50” in Service code, and change parameter you need.)

3.1.6 Calibrating the Analyzer for Correct Readings

For details on the calibration of the analyzer for correct readings, see Chapter 8, 9 or 10.

3.1.7 Checking the Analyzer for Performance

When the required parameters have been completely set, bring into operation all equipment composing the measurement loop. Keep this equipment operating for a while. After making sure there is no problem with the equipment, go into normal operation.

For reference, the following summarizes the setting functions (related to signals) of the GD402 analyzer that are used to obtain the optimum operating conditions.

[Functions Related to the Output Signal]

The output signal can be held at a value immediately before calibration or at a desired value during calibration or at the setting/service level. This is to prevent the output signal from adversely affecting the operation of the equipment configuring the measurement loop (default setting: the output signal is held at the value immediately before).

[Functions Related to the High/Low Limit Alarm Contact Output]

Select the parameters for which the alarms are raised, and then set their respective high/low limit set-points. The analyzer transmits an alarm contact signal if any of these setpoints is exceeded. (Define the voltage-free contacts and the state of contacts at the service level.)

[Functions Related to the FAIL Contact Signal]

If a FAIL state occurs, an appropriate message appears on the LCD display. For details on these functions, see Chapter 11.

[Contact output of Hydrogen purity / Replacement meter]

According to switching of Replacement meter, the status of contact and display (LED) is changed as following. (The status of contact output are to be set in Service level, CODE 05.)

• Hydrogen purity meter

	RANGE	FUNC	SEL GAS	LED
Replacement Meter	H ₂ in CO ₂ AIR in CO ₂	—	ACTIVE NORMAL	ON OFF
Hydrogen Purity/ Replacement Meter	H ₂ in AIR H ₂ in CO ₂ AIR in CO ₂	NORMAL ACTIVE ACTIVE	NORMAL ACTIVE NORMAL	OFF ON OFF

FUNC: Identification signal of Hydrogen purity/Replacement Meter. (contact)

SEL GAS: Range identification signal of Replacement Meter. (contact)

[The status of contact output]

	FAIL	SEL	FUNC	MAINT	ALM
Power Supply OFF	OPEN	CLOSE	CLOSE	CLOSE	CLOSE
Power Supply ON	NORMAL: CLOSE FAILURE: OPEN	The status of contact are to be set in Service level, CODE 05.			

3.2 Normal Operation

In normal operation, there is no need for working with the GD402 analyzer except when calibrating it. Unless there is any failure found, carry out maintenance, inspection, and so on at the same time the analyzer is calibrated. The analyzer is designed to prohibit you from calibrating it or setting each parameter unless you have entered the password (XXX). (See section “4.2 Setting Lists”.)

3.2.1 Starting Operation

Follow the procedure below to start operation.

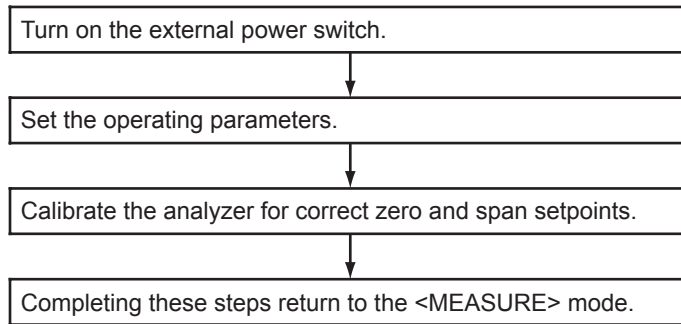

F0307.ai

The following details the operations required in this procedure.

- (1) The analyzer, when turned on, indicates the density value. See Figure 5.2, 6.3 or 7.3 for the operations used to change to the required unit of density.
- (2) Set the relevant operating parameters by checking and modifying their default values in order to meet individual operating requirements.
- (3) Supply the zero and span gases to check readings. If the readings contain errors, the analyzer must be calibrated. For details on calibration, see Chapter 8, 9 or 10.
- (4) When calibration is complete, the analyzer returns to the <MEASURE> mode.

3.2.2 Corrective Actions in Case of Failure

If the GD402 analyzer senses a failure, it sends out a FAIL contact output signal through terminals 18 and 19. In such a case, the output signal is held at either the value held immediately before or at the preset value for each setting.

The message field indicates the type of error by the error code. Should a failure occur, check the nature of the failure and take corrective action without delay. Table 3.1 summarizes the numeric codes of errors that may occur in the measurement mode. For details on each type of error, see Table 11.2 on page 11-4.

Table 3.1 Errors that May Occur in the Measurement Mode

Error No.	Nature of Failure	Corrective Actions
Err. 01	Sensor oscillation shutdown	Reset the power and contact service personnel.
Err. 02	Faulty oscillation frequency of sensor	Reset the power and contact service personnel.
Err. 03	Sensor's failure to detect temperature	Contact service personnel.
Err. 04	Failure in A/D converter	Contact service personnel.
Err. 05	Failure in memory	Contact service personnel.

3.2.3 Inspection and Maintenance

Due to the operating principle (polymodal self-excited oscillation circuitry), the sensor has only the slightest marginal drift, which is, in fact, generated by the detector itself or a result of contamination from dust, etc. Therefore, the GD402 analyzer basically does not have to undergo any inspection or maintenance. Periodical inspection and maintenance are recommended however, to ensure optimum performance. For details on inspection and maintenance, see Chapter 11.

3.3 Shutdown and Restart

3.3.1 Measures for Shutdown

Data set in the converter are retained even when the power is turned off. If the system needs to be shut down over a prolonged period, turn off the power. Any foreign matter that accumulates and hardens on the detector or any corrosive substance that condenses on the detector can be the cause of problems. Fully purge the sensor with fresh air (instrument air). Cleaning of the sensor is also recommended where it is appropriate; consult Yokogawa.

3.3.2 Measures for Restarting

Visually check all component equipment of the analyzer before you resume measurement after a long-term shutdown of the analyzer. Re-confirm the wiring and piping have tight connections .

Blank Page

4. FUNCTIONS

When using the GD402 analyzer, set data and select functions according to the measuring conditions. This chapter describes the structures of function.

4.1 Summary of Setting Operations

4.1.1 Measurement, Operation, Setting and Service

Parameters can be set by selecting the appropriate mode. These modes are classified into four levels: measurement, operation, setting, and service.

[Measurement Level]

This level is used to view various measured values.

[Operation Level]

This is basically a level used to select between items to be viewed in the measurement mode and a parameter to be measured, and to perform operations relating to routine inspection and/or maintenance such as calibration.

[Setting Level]

At this level, there are modes for setting data related to analog outputs, calibration data and alarm contact outputs.

[Service Level]

The GD402 analyzer has numerous functions. At this level, there are modes for selecting the functions necessary for system operation.

4.1.2 Key Operations

Keys can be operated in an "interactive" manner. Operate the keys according to the information in the data or message field, information pointed to by the pointer (mode indication), and/or information in the key operation indicators. For basic key operations, see Subsection 3.1.4.

[Interactions]

- **Flashing pointer**

This inquires whether you want to go to the mode being pointed at or move the pointer to the next mode. When the system indicates the modes for the setting or service level, the message is preceded by an asterisk (*). When you enter one of the modes, the pointer stops flashing and remains continuously lit.

- **Flashing key operation indicators**

This prompts you to choose an indicator from the indicators flashing on the display and press the corresponding key.

- **Flashing numerals in data field**

This asks whether you want to change the flashing numeral or move to the next digit and have it flash. Press the appropriate key. If neither of these actions is required, press the [ENT] key.

[Aborting the Setting Operation]

Press the [MODE] key. Normally, the [MODE] key is used to move from the measurement (<MEASURE>) mode to a mode at the operation level. It is also used to return to the measurement mode from other modes.

4.1.3 Points to Be Noted When Making Settings

(1) Password

Password is not selected in first condition. When password is necessary, refer to Section “4.2 Setting Lists” and selected password what you need. If password is selected, you are not allowed to access any mode unless you enter the given password (XXX).

A password prompt appears when:

- at the operation level, the [MODE] key is pressed during the measurement mode, or
- at the setting level, the [*] key is pressed during the measurement mode.
- at the service level, the [YES] key is pressed with [*SERV] displayed.

(2) Related Parameters

If any change has been made to a particular parameter, check its relationship with parameters set in other modes so that there will not be any inconsistency.

[Parameters to Check When the Analog Output Settings Are Changed]

- a. High/low limit alarm set-points and contact outputs
- b. Fixed value for held output signal

[Parameters to Check When High/Low limit Alarm Set-points Are Changed]

- a. Alarm actions (low limit alarm or high limit alarm operation)
- b. Analog output settings

4.2 Setting Lists

The GD402 Gas Density meter comes in 3 different models (and model codes) to meet several measurement conditions: (1) Density meter, (2) Calorie meter, and (3) Hydrogen purity meter.

The values measured by the different models are as follows.

- (1) Density meter : Density, compensated density, specific gravity, molecular weight, concentration and calorie.
- (2) Calorie meter : Density, compensated density, and calorie
- (3) Hydrogen purity meter : Density, compensated density, H₂ in Air, Air in CO₂, and H₂ in CO₂.

The following describes the conditions required when using the GD402 Gas Density meter.

After following the procedure below, set a model code and select a password.

- (1) Select a model code for each service in “Selecting the instruments” function of each service code. For example, if you select model 1, you can use the analyzer as a calorie meter. (See Figure 5.29, Figure 6.30 or Figure 7.27.)

code 0 : Density meter

1 : Calorie meter

2 : Hydrogen purity meter

- (2) Next, set a password, if you need. (See Figure 5.27, Figure 6.28 or Figure 7.25.)

- (3) Other parameter settings can now be set.

Set parameters according to the selected model code and password.

- (1) Density meter: See Chapter 5. , (2) Calorie meter: See Chapter 6. , (3) Hydrogen purity meter: See Chapter 7.

5. DENSITY / PARAMETER SETTING

CAUTION

Password is not selected in first condition. When password is necessary, refer to Section "4.2 Setting Lists".

This chapter describes how to set parameters of Density meter.

If select Calorie meter, see Chapter 6.

If select Hydrogen purity meter, see Chapter 7.

Conversion Table

1 lb/ft ³	= 16.01847 kg/m ³
1 kBTU/ft ³	= 37.25901232 MJ/m ³
X degF	= (X-32)/1.8
1 psi	= 6.894756794 kPa
Density of Air	= 1.2928 kg/m ³ = 0.08070684 lb/ft ³

5.1 Setting Parameters

Subsections 5.1.1 to 5.1.4 show the setting parameters for each level.

5.1.1 Setting Parameters at Measurement Level

When turned on, the analyzer starts up in the measurement mode (<MEASURE>).

Table 5.1 Setting Parameters at Measurement Level

Mode/Setting parameter	Display	Data to be Set (or Conditions)	Remarks
Measurement mode Indication of measurement value Physical density Compensated density Specific gravity Calorific value Molecular weight Concentration Indication of message Unit Error symbol and number Alarm mark and number Indication of HOLD and FAIL HOLD FAIL	KG/M3 LB/FT3 KG/M3 LB/FT3 SP GR MJ/M3 KBTU MOL VOL% ERR.NO ALM.NO HOLD FAIL	Set the unit in CODE 21. Set the unit in CODE 21. Set the unit in CODE 22.	See Figure 5.2 for key operation. The unit is the one set in the service level. Appears if an error occurs. Appears if an alarm occurs. Appears even during other modes. Appears during a HOLD state. Appears if a failure occurs.
DISP mode Physical density Compensated density Specific gravity Calorific value Molecular weight Concentration Sample gas temperature Sample gas pressure Analog output 1 (%) Analog output 2 (%)	DISP KG/M3 LB/FT3 KG/M3 LB/FT3 SP GR MJ/M3 KBTU MOL VOL% °C °F KPA MPA PSI MA1% MA2%	Set the unit in CODE 21. Set the unit in CODE 21. Set the unit in CODE 22. Set the unit in CODE 23. Set the unit in CODE 20.	See Figure 5.2 for key operation. Selection of parameters to be measured in the measurement mode. Read-only Read-only Read-only Read-only

5.1.2 Setting Parameters at Operation Level

Press the [MODE] key and enter the password (XXX) to gain access to this level (see Figure 5.1 for key operation).

Table 5.2 Setting Parameters at Operation Level

Mode/Setting parameter	Display	Data to be Set (or Conditions)	Remarks
Calibration mode Semi-automatic calibration Manual calibration Setting of zero-point density Setting of span-point density	SEM.CAL MAN.CAL Z_DNS S_DNS	One-touch calibration	See Figure 8.3 for key operation. See Figure 8.4 for key operation.
Zero/span-gas valve operation Zero-gas valve operation Span-gas valve operation Sample-gas valve operation	VALVE V_ZERO V_SPAN	No setting is required for manual calibration Control of zero-gas valve Control of span-gas valve Switching between sample and calibration gases	See Figure 8.1 for key operation.

5.1.3 Setting Parameters at Setting Level

Press the [*] key and enter the password (XXX) to gain access to this level (see Figure 5.4 for key operation).

Table 5.3 Setting Parameters at Setting Level

Mode/Setting parameter	Display	Data to be Set (or Conditions)	Remarks
Analog output setting Output 1 Set a parameter to be output Set the zero and span points Physical density Compensated density Specific gravity Calorific value Molecular weight Concentration Output 2 (same as output 1)	*RANGE *OUT1 *DENS *C_DNS *SP_GR *CALRY *MOL *CONCT *TEMP *PRESS *Z_DNS,*S_DNS *Z_CP.D,*S_CP.D *Z_SPC,*S_SPC *Z_CAL,*S_CAL *Z_MOL,*S_MOL *Z_CON,*S_CON *OUT2	Physical density Compensated density Specific gravity Calorific value Molecular weight Concentration Gas temperature Gas pressure 00.0000 to 60.0000 kg/m ³ 0.00000 to 4.00000 lb/ft ³ 0.0000 to 6.0000 kg/m ³ 0.00000 to 0.40000 lb/ft ³ 0.0000 to 5.0000 000.000 to 133.000 MJ/m ³ 0.0000 to 3.5000 kBTU/ft ³ 000.00 to 140.00 000.0 to 100.0	See Figure 5.4 for key operation. No setting is required if the parameter is temperature or pressure.
Setting calibration data Zero-point density Span-point density Output hold value during calibration Setting of preset value (Only if the preceding parameter is set to 2 (preset value))	*CAL.DT *Z_DNS *S_DNS *C_HLD *PR.SET	0.0000 to 6.0000 kg/m ³ 0.00000 to 0.40000 lb/ft ³ 0.0000 to 6.0000 kg/m ³ 0.00000 to 0.40000 lb/ft ³ · Disable: 0 · Enable (value immediately before) : 1 · Enable (preset value) : 2 -10.0 to 110.0	See Figure 8.2 for key operation.
Alarm-point setting Select a parameter for which an alarm is set Physical density Compensated density Specific gravity Calorific value Molecular weight Concentration Set the high/low limits Physical density Compensated density Specific gravity Calorific value Molecular weight Concentration	*ALARM *DENS *C_DNS *SP_GR *CALRY *MOL *CONCT *L_DNS,*H_DNS *L_CP.D,*H_CP.D *L_SPC,*H_SPC *L_CAL,*H_CAL *L_MOL,*H_MOL *L_CON,*H_CON	00.0000 to 60.0000 kg/m ³ 0.00000 to 4.00000 lb/ft ³ 0.0000 to 6.0000 kg/m ³ 0.00000 to 0.40000 lb/ft ³ 0.0000 to 5.0000 000.000 to 133.000 MJ/m ³ 0.0000 to 3.5000 kBTU/ft ³ 000.00 to 140.00 000.0 to 100.0	See Figure 5.5 for key operation.

5.1.4 Setting Parameters at Service Level

Press the [*] key and enter the password (XXX) to select the service level. When you select this level, the analyzer shows a Code No. promptly. Type the appropriate code number and press the [ENT] key.

Table 5.4 Setting Parameters at Service Level

Code No.	Item	Display	Data to be Set (or Conditions)	Remarks
01	Setting of hold during maintenance Hold enable/disable	*M_HLD	· Disable : 0 · Enable (value immediately before) : 1	See Figure 5.7 for key operation. If "preset value" is selected in the preceding parameter.
	Setting of preset hold value	*PR.SET	· Enable (preset value) : 2 -10.0 to 110.0	
02	Setting of hold against errors Hold enable/disable	*E_HLD	· Disable : 0 · Enable (value immediately before) : 1	See Figure 5.8 for key operation. If "preset value" is selected in the preceding parameter.
	Setting of preset hold value	*PR.SET	· Enable (preset value) : 2 -10.0 to 110.0	
04	Setting of output-smoothing constants	*SMOTH	00 to 60	See Figure 5.9 for key operation.
05	Setting of contact outputs status	*CNTCT	00 to 15	See Figure 5.10 for key operation.
10	Setting of pressure compensation Enable/disable/fixed value	*P.COMP	· Disable: 0 · Enable (measured value) : 1 · Enable (fixed value) : 2	See Figure 5.11 for key operation. If "fixed value" is selected in the preceding parameter.
	Setting of fixed value for pressure compensation	*P.FIX	0.10 to 999.99 kPa, 0.0001 to 9.9999 MPa, 0.015 to 99.999 psi	
11	Setting for compensated density measurement			See Figure 5.12 for key operation.
	Setting of reference temperature Setting of reference pressure	*C.D.TMP *C.D.PRS	-20.0 to 80.0 °C, - 4.0 to 176.0 °F 0.10 to 999.99 kPa, 0.0001 to 9.9999 MPa, 0.015 to 99.999 psi	
12	Setting of gas pressure Setting of zero gas pressure	*Z_PRS	0.01 to 999.99 kPa, 0.0001 to 9.9999 MPa, 0.015 to 99.999 psi	See Figure 5.13 for key operation.
	Setting of span gas pressure	*S_PRS	0.10 to 999.99 kPa, 0.0001 to 9.9999 MPa, 0.015 to 99.999 psi	
13	Selection for automatic calibration	*AUTO.C	· Disable : 0 · Enable : 1	See Figure 5.14 for key operation.
14	Setting for remote semi-automatic calibration	*REMOT	· Disable : 0 · Enable : 1	See Figure 5.15 for key operation.
15	Setting of data for automatic/semi-automatic calibration			See Figure 5.16 for key operation.
	Selection of calibration item	*CAL.P	Zero and span : 0 Zero : 1 Span : 2	
	Setting of calibration time	*CAL.T	00 to 59	
	Setting of stabilization time	*STAB.T	00 to 59	
	Setting of calibration starting time			
Setting of year/month/day	*Y_M_D	00.01.01 to 99.12.31		
Setting of hour/minute	*H_M	00.00 to 23.59		
Selection of unit of calibration interval	*CYCL.U	Hour : 0 Day : 1		
Selection of calibration interval	*CYCL.T	Hour : 00 to 23 Day : 000 to 255		

Table 5.4 Setting Parameters at Service Level

Code No.	Item	Display	Data to be Set (or Conditions)	Remarks
20	Selection of pressure unit	*PRES.U	· kPa : 0 · MPa : 1 · psi : 2	See Figure 5.17 for key operation.
21	Selection of density unit	*DENS.U	· kg/m ³ : 0 · lb/ft ³ : 1	See Figure 5.18 for key operation.
22	Selection of calorific value unit	*CAL.U	· MJ/m ³ : 0 · kBTU/ft ³ : 1	See Figure 5.19 for key operation.
23	Selection of temperature unit	*TEMP.U	· °C : 0 · °F : 1	See Figure 5.20 for key operation.
30	Setting of calendar Setting of year/month/day Setting of hour/minute	*Y_M_D *H_M	00.01.01 to 99.12.31 00.00 to 23.59	See Figure 5.21 for key operation. For leap years, the setting can cope with 'February 29'.
31	Showing/hiding of negative measured values (-)	*MINUS	· Show : 0 · Hide : 1	See Figure 5.22 for key operation.
40	Indication of calibration coefficients (read-only) Zero Span	*C_K_Z *C_K_S	SX.XXXX X.XXXX	See Figure 5.23 for key operation. S of SX.XXXX means Marks such as a plus or the minus.
41	Indication of oscillation frequency (read-only) Frequency F2 Frequency F4 Frequency ratio	*F2.KHZ *F4.KHZ *F2/F4	X.XXXXX X.XXXXX X.XXXXX	See Figure 5.24 for key operation.
42	Indication of software version (read-only)	*REV	X.XX	See Figure 5.25 for key operation.
43	Setting of high-resolution mode	*S_CYC	· Normal : 0 · High-resolution : 1	See Figure 5.26 for key operation.
44	Setting of password	*PASS	0.0.0 to 9.9.9	See Figure 5.27 for key operation.
45	Selecting Battery alarm detection	*BAT	· Non detection : 0 · Detection : 1	See Figure 5.28 for key operation.
50	Selecting the instruments	*MODEL	· Density meter : 0 · Calorie meter : 1 · Hydrogen purity, replacement meter : 2	See Figure 5.29 for key operation.
82	Setting Detector Constant			See Figure 5.30 for key operation.

5.2 Parameter Setting

[Aborting the Setting Operation]

Press the [MODE] key. Normally, the [MODE] key is used to move from the measurement (<MEASURE>) mode to a mode at the operation level. It is also used to return to the measurement mode from other modes.

5.2.1 Parameter Setting at Operation Level

To move to the operation level, press the [MODE] key and then enter the password (XXX). Password is not selected in first condition. When password is necessary, refer to Section 4.2 "Setting Lists" and selected password what you need.

The operation level offers two mode categories: the measurement and calibration operation modes.

Note that the function for which you have set a data value at the setting level does not work at all if that function is turned off at another level. For this reason, care must be taken when dealing with modes that relate to each other.

This subsection explains the operating procedures for the levels/modes noted below. The calibration operation mode is discussed in Chapter 8.

- (1) Operation level
- (2) Display mode (DISP mode)

(1) Operation Level

Select a mode from the following four choices of the operation level. Each press of the [NO] key cycles through the choices in the order shown below:

1. Display mode [DISP]
2. Semi-automatic calibration mode [SEM.CAL]
3. Manual calibration mode [MAN.CAL]
4. Valve operation mode [VALVE]

Press the [YES] key to enter the desired mode when it is indicated.

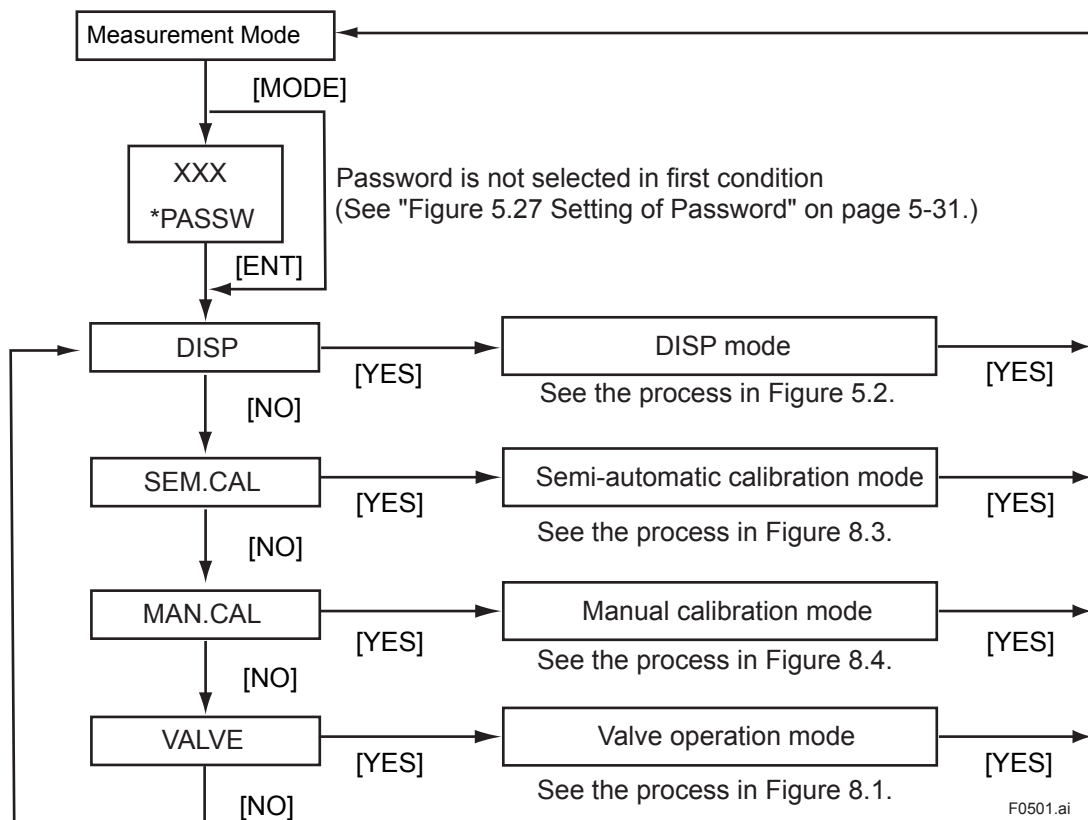

You can abort the setting operation in any of the modes by pressing [MODE] key. Doing this will return the analyzer to the measurement mode.

Figure 5.1 Modes of Operation Level

(2) Display Mode

Select one of the following ten parameters to be shown in the message field. Each press of the [NO] key cycles through the choices in the order shown below:

1. Physical density [XX.XXXX KG/M3] or [X.XXXXX LB/FT3]
(depends on the setting of CODE 21)
2. Compensated density [X.XXXX KG/M3] or [X.XXXXX LB/FT3]
(depends on the setting of CODE 21)
3. Specific gravity [X.XXXX SP GR]
4. Calorific value [XXX.XXX MJ/M3] or [X.XXXX KBTU]
(depends on the setting of CODE 22)
5. Molecular weight [XXX.XX MOL]
6. Concentration [XXX.X VOL%]
7. Temperature [XXX.X °C] or [XXX.X °F]
(depends on the setting of CODE 23)
8. Pressure [XXX.XX KPA] or [X.XXXX MPA] or [XX.XXX PSI]
(depends on the setting of CODE 20)
9. Current for analog output 1 (%) [XXX.X MA1%]
10. Current for analog output 2 (%) [XXX.X MA2%]

Show the desired choice and press the [YES] key. That choice is set as a parameter to be measured in the measurement mode (<MEASURE>). Parameters 1 to 6 are configurable, while parameters 7 to 10 are read-only.

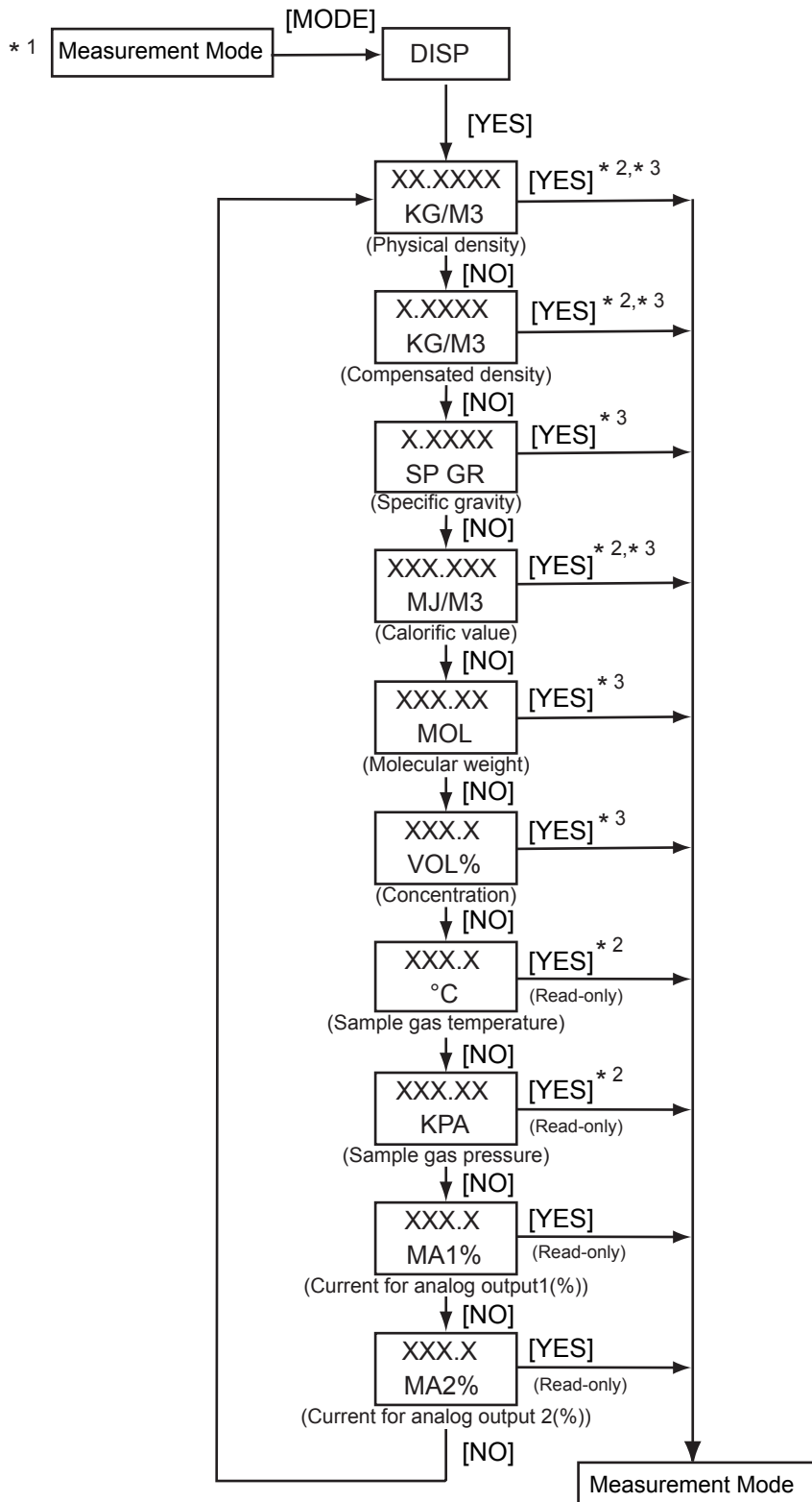

F0502.ai

*1: See "Figure 5.1 Modes of Operation Level" on page 5-7.

*2: The unit is the one set in the service level.

*3: Press the [YES] key to show the parameter in the measurement mode.

Figure 5.2 Display Mode (DISP Mode)

5.2.2 Parameter Setting at Setting Level

To move to the setting level, press the [*] key and then enter the password (XXX). The main task at the setting level is to set data values such as the measuring range values.

Note that the function for which you have set data values at the setting level, will not work if that function is turned off at another level. For this reason, care must be taken when dealing with modes that relate to each other. The setting level has four levels/modes, as shown below, although this subsection explains only the analog output setting and alarm-point setting modes. The calibration parameter setting mode is discussed in Chapter 8.

1. Analog output setting mode [*RANGE]
2. Calibration parameter setting mode [*CAL.DT]
3. Alarm-point setting mode [*ALARM]
4. Service level [*SERVC]

Select a mode from the above four choices. Each press of the [NO] key cycles through the choices in sequence. Press the [YES] key to enter the desired mode when it is indicated.

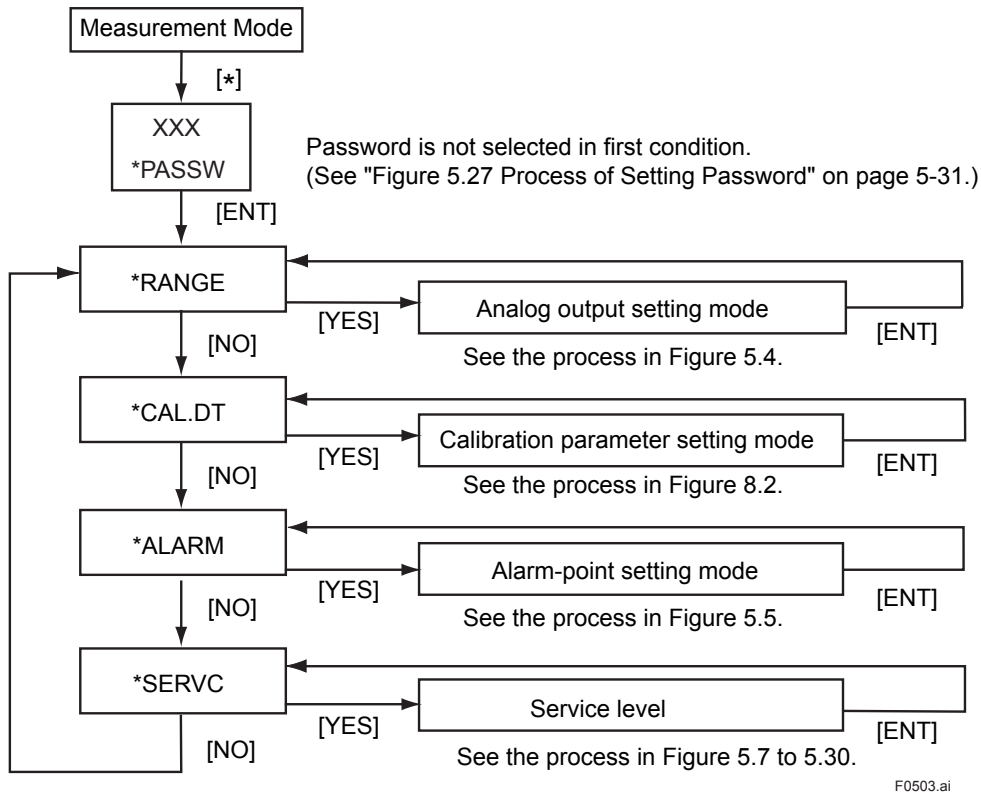

F0503.ai

You can abort the setting operation in any of the modes by pressing the [MODE] key. Doing this will return the analyzer to the measurement mode.

Figure 5.3 Process at the Setting Level

1. Analog Output Setting Mode [*RANGE]

The analog output has output 1 and output 2. Only output 1 can be used for communication purposes.

Set a range appropriate for 4-20 mA DC output signals. The range has two set-points: the lower limit (zero point) of the range corresponding to the minimum (0%) of a given output signal and the upper limit (span point) of the range corresponding to the maximum (100%) of the given output signal.

(1) Output1 [*OUT1]

(a) Select a parameter to be output.

- Physical density [*DENS]
- Compensated density [*C_DNS]
- Specific gravity [*SP_GR]
- Calorific value [*CALRY]
- Molecular weight [*MOL]
- Concentration [*CONCT]
- Gas temperature [*TEMP]
- Gas pressure [*PRESS]

(b) Set the zero and span points. (This item is not applied if temperature or pressure are chosen as the parameter in item (a) above.)

- Physical density [*Z_DNS], [*S_DNS]
Configure range: 00.0000 to 60.0000 (kg/m³),
0.00000 to 4.00000 (lb/ft³)
- Compensated density [*Z_CP.D], [*S_CP.D]
Configure range: 0.0000 to 6.0000 (kg/m³),
0.00000 to 0.40000 (lb/ft³)
- Specific gravity [*Z_SPC], [*S_SPC]
Configure range: 0.0000 to 5.0000
- Calorific value [*Z_CAL], [*S_CAL]
Configure range: 000.000 to 133.000 (MJ/m³),
0.0000 to 3.5000 (kBTU/ft³)
- Molecular weight [*Z_MOL], [*S_MOL]
Configure range: 000.00 to 140.00
- Concentration [*Z_CON], [*S_CON]
Configure range: 000.0 to 100.0

(2) Output 2 [*OUT2]

The same parameters as those of item (1) apply.

(3) Entries for Calorie and Concentration Measurement

Measuring the calorific value (or concentration) requires the density to be correlated with the calorific value (or concentration) by a linear equation (linear proportion). Therefore, use the gas calorie meter in order to measure the calorific value as accurately as possible.

The relationship must be given by $Y=aX+b$, where Y is the calorific value (MJ/m^3) and X is the density (kg/m^3).

- Example of Entries for Calorie Measurement

Assuming the relationship is given by “calorific value = $58 \times \text{density} + 6$ (MJ/m^3)”, the density ranges from 0.5 to 0.7 kg/m^3 while the calorific value ranges from 35 to 46.6 MJ/m^3 .

The entries for the [*CALRY] parameter (see Figure 5.4) therefore are:

*Z_CAL: 35

*S_CAL: 46.6

*Z_CL.D: 0.5

*S_CL.D: 0.7

- Example of Entries for Concentration Measurement

Assume we measure the concentration of hydrogen mixed with nitrogen and the relationship is given by:

$$D = aX + b$$

where,

D =density of gas being measured (hydrogen: 0.0899 kg/m^3 ; nitrogen: 1.2504 kg/m^3),

and

X =volume percent (vol%) of hydrogen gas,

then the equation above is calculated as:

$$\begin{aligned} D &= (0.0899-1.2504)(X/100) + 1.2504 \\ &= -1.1605(X/100) + 1.2504 \end{aligned}$$

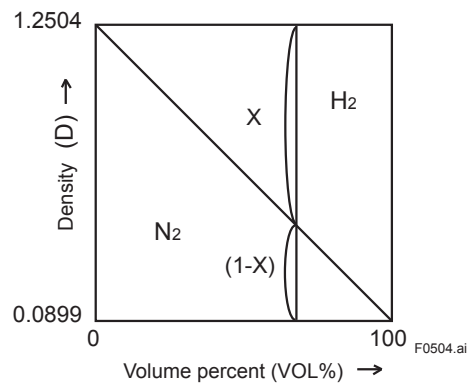

The entries for the [*CONCT] parameter (see Figure 5.4) therefore are:

*Z_CON: 0

*S_CON: 100

*Z_CN.D: 1.2504

*S_CN.D: 0.0899

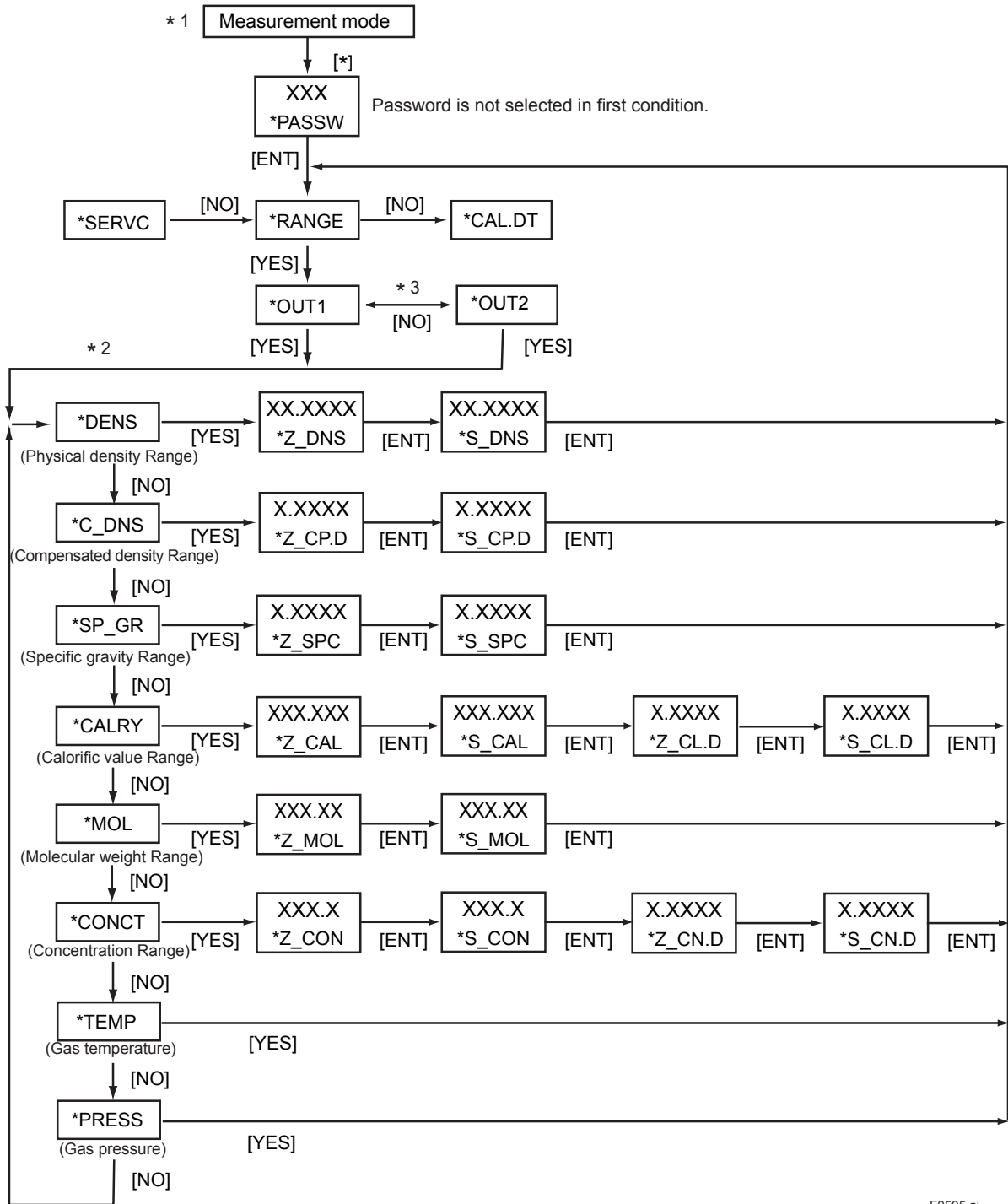

F0505.ai

*1: You can abort the setting operation in any of the modes by pressing [MODE] key. Doing this will return the analyzer to the measurement mode.

*2: The display shows the previous parameter first.

*3: Each press of the [NO] key toggles between the parameters [*OUT1] and [*OUT2].

Figure 5.4 Process of the Analog Output Setting Mode

2. Alarm-point Setting Mode [*ALARM]

Set the upper /lower limits for the measured values of the parameters noted below, for the purpose of raising an alarm.

(a) Select a parameter for which alarms are raised.

- Physical density [*DENS]
- Compensated density [*C_DNS]
- Specific gravity [*SP_GR]
- Calorific value [*CALRY]
- Molecular weight [*MOL]
- Concentration [*CONCT]

Press the [YES] key to enter the desired mode when it is indicated.

(b) Set the upper/lower limits.

- Physical density [*L_DNS], [*H_DNS]
Configure range: 00.0000 to 60.0000 (kg/m³),
0.00000 to 4.00000 (lb/ft³)
- Compensated density [*L_CP.D], [*H_CP.D]
Configure range: 0.0000 to 6.0000 (kg/m³),
0.00000 to 0.40000 (lb/ft³)
- Specific gravity [*L_SPC], [*H_SPC]
Configure range: 0.0000 to 5.0000
- Calorific Value [*L_CAL], [*H_CAL]
Configure range: 000.000 to 133.000 (MJ/m³),
0.0000 to 3.5000 (kBTU/ft³)
- Molecular weight [*L_MOL], [*H_MOL]
Configure range: 000.00 to 140.00
- Concentration [*L_CON], [*H_CON]
Configure range: 000.0 to 100.0

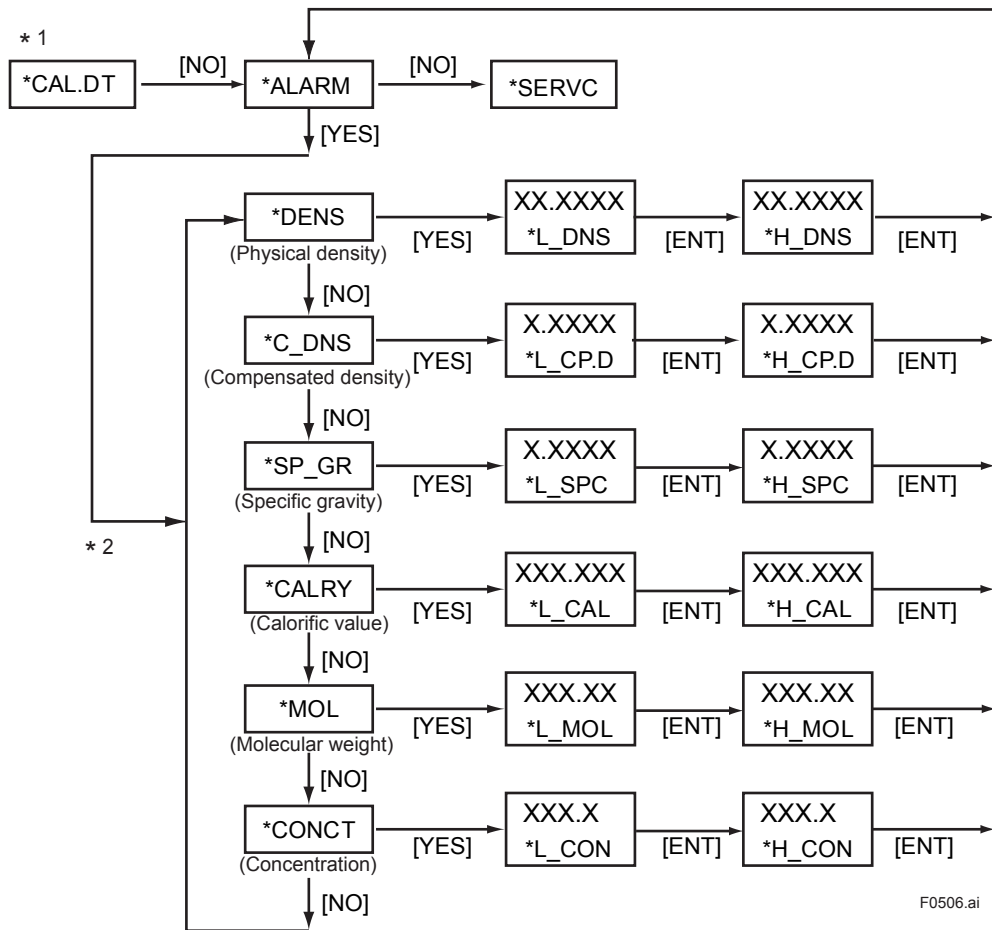

*1: See "Figure 5.3 Process at the Setting Level" on page 5-10.

*2: The display shows the previous parameter first.

Figure 5.5 Process of the Alarm-point Setting Mode

5.2.3 Parameter Setting at Service Level

To move to the service level, select [*SERVC] at the setting level, and press the [YES] key. (see Figure 5.3 on page 5-10.) The main task at the setting level is to set data values such as a measuring range. To go into each mode of the service level, enter the appropriate code number.



CAUTION

DO NOT enter codes other than those listed in Table 5.4. A change to the settings of any unlisted code can result in the failure of the analyzer to operate properly. If you have entered a wrong code number by mistake, press the [MODE] key to return to the measurement mode(<MEASURE>). You may exit the mode of that wrong code by pressing the [ENT] key, if you haven't made any change to the relevant data.

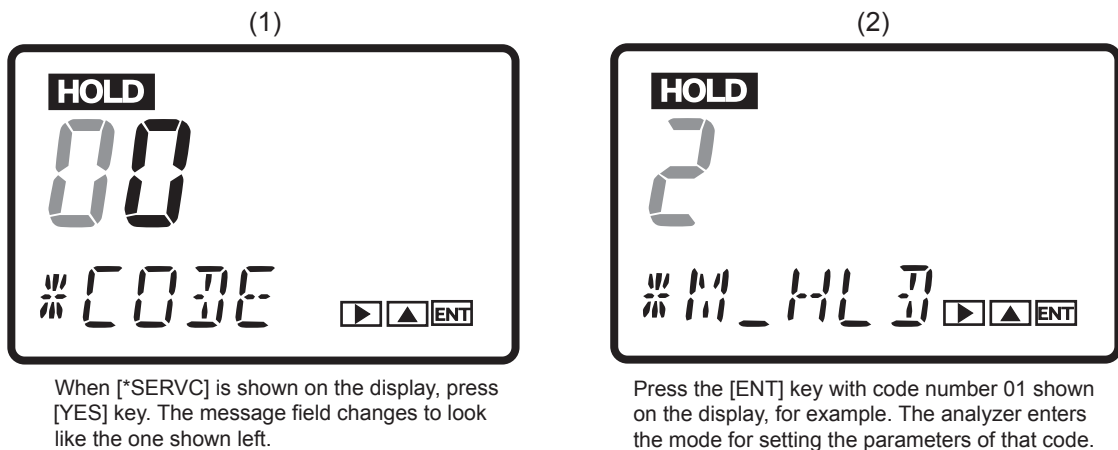

F0507.ai

Figure 5.6 Entry of Code Number at Service Level

The following explains the parameter setting procedures in the order of code numbers.

CODE 01: Setting of Hold during Maintenance

This setting determines whether or not the output signal is held during maintenance. As a value to be held, you can select either a value immediately before or a preset value.

(a) Hold enable/disable [*M_HLD]

- Disable: 0
- Enable: 1
- Enable (preset value): 2

(b) Setting of preset hold value [*PR.SET]

This item applies if item (a) above is set to "2".

Configurable range: -10.0 to 110.0 (percent of analog output)

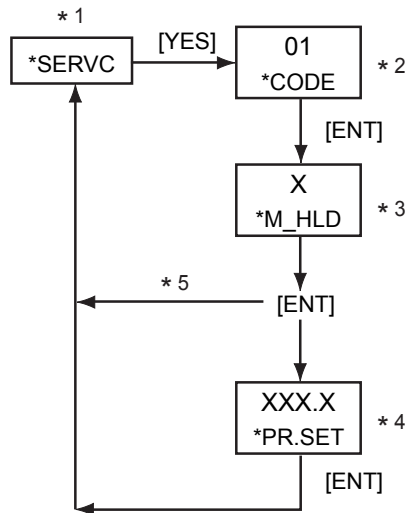

F0508.ai

- *1: See "Figure 5.3 Process at the Setting Level" on page 5-10.
- *2: Enter the code number.
- *3: Set a value using the [^] and [ENT] keys.
- *4: Set a value using the [>], [^] and [ENT] keys.
If you enter a value that exceeds the limits, the display shows [*OVER].
Press the [YES] or [NO] key to re-set the value.
- *5: Setting 0 or 1 returns to the service level with the indication [*SERVC].

Figure 5.7 Setting of Hold during Maintenance

CODE 02: Setting of Hold in the Event of Error

This setting determines whether or not the output signal is held if an error occurs. You can select either the value immediately prior to the error or a preset value as the value to be held.

(a) Hold enable/disable [*E_HLD]

- Disable: 0
- Enable: 1
- Enable (preset value): 2

(b) Setting of preset hold value [*PR.SET]

This item applies if item (a) above is set to "2".

Configurable range: -10.0 to 110.0 (percent of analog output)

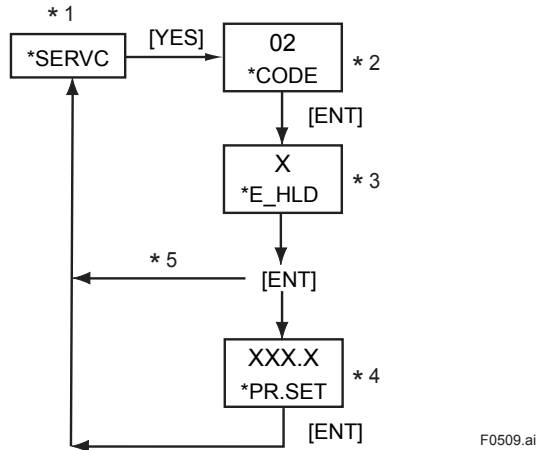

- *1: See "Figure 5.3 Process at the Setting Level" on page 5-10.
- *2: Enter the code number.
- *3: Set a value using the [^] and [ENT] keys.
- *4: Set a value using the [>], [^] and [ENT] keys.
If you enter a value that exceeds the limits, the display shows [*OVER].
Press the [YES] or [NO] key to re-set the value.
- *5: Setting 0 or 1 returns to the service level with the indication [*SERVC].

Figure 5.8 Setting of Hold in the Event of Error

CODE 04: Setting of Output-smoothing Constants [*SMOTH]

This setting defines the constants for output smoothing. This smoothing constants is output-smoothing constants of converter (electrical circuit boards).

Configurable range: 00 to 60 (unit : second)

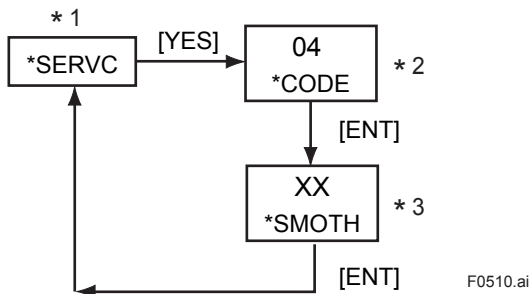

- *1: See "Figure 5.3 Process at the Setting Level" on page 5-10.
- *2: Enter the code number.
- *3: Set a value using the [>], [^] and [ENT] keys.
If you enter a value that exceeds the limits, the display shows [*OVER].
Press the [YES] or [NO] key to re-set the value.

Figure 5.9 Setting of Output-smoothing Constants

CODE 05: Setting of Contact Outputs Status [*CNTCT]

This setting defines the status of the contact outputs.

Configurable range: 00 to 15

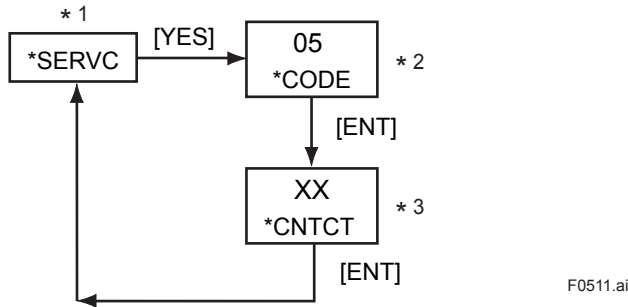

- *1: See "Figure 5.3 Process at the Setting Level" on page 5-10.
- *2: Enter the code number.
- *3: Set a value using the [>], [^] and [ENT] keys.
If you enter a value that exceeds the limits, the display shows [*OVER].
Press the [YES] or [NO] key to re-set the value.

Figure 5.10 Setting of Contact Outputs Status

Each contact output takes either of the following two status (in table), depending on the value you set.

Value	ZERO contact	SPAN contact	MAINT contact	ALM contact
0	NO	NO	NO	NO
1	NO	NO	NO	NC
2	NO	NO	NC	NO
3	NO	NO	NC	NC
4	NO	NC	NO	NO
5	NO	NC	NO	NC
6	NO	NC	NC	NO
7	NO	NC	NC	NC
8	NC	NO	NO	NO
9	NC	NO	NO	NC
10	NC	NO	NC	NO
11	NC	NO	NC	NC
12	NC	NC	NO	NO
13	NC	NC	NO	NC
14	NC	NC	NC	NO
15	NC	NC	NC	NC

NO: means "normally open"
NC: means "normally closed"

CODE 10: Setting of Pressure Compensation

This setting determines whether or not the measured density should be compensated by the gas pressure. The density can be compensated to either the value immediately before the error or a fixed value.

(a) Enable/disable/fixed value [*P.COMP]

- Disable: 0
- Enable (value immediately before): 1
- Enable (fixed value): 2

(b) Setting of fixed value for pressure compensation [*P.FIX]

This item applies if item (a) above is set to "2".

Configurable range: 0.10 to 999.99 (for kPa),
 0.0001 to 9.9999 (for MPa),
 0.015 to 99.999 (for psi)

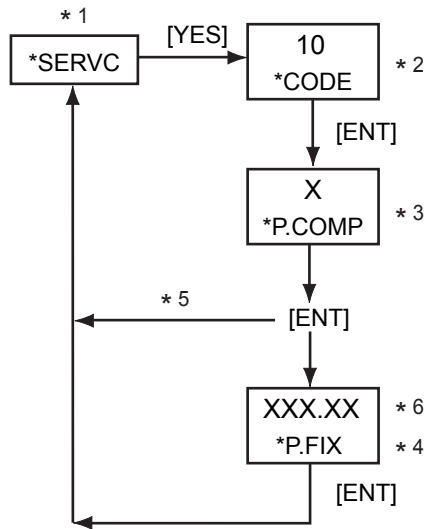

F0512.ai

- *1: See "Figure 5.3 Process at the Setting Level" on page 5-10.
- *2: Enter the code number.
- *3: Set a value using the [^] and [ENT] keys.
- *4: Set a value using the [>], [^] and [ENT] keys.
 If you enter a value that exceeds the limits, the display shows [*OVER].
 Press the [YES] or [NO] key to re-set the value.
- *5: Setting 0 or 1 returns to the service level with the indication [*SERVC].
- *6: The position of the decimal point changes depending on the setting of CODE 20.
 If the code is set to "0" (kPa), the reading is XXX.XX;
 if the code is set to "1" (MPa), the reading is X.XXXX;
 if the code is set to "2" (psi), the reading is XX.XXX.

Figure 5.11 Setting of Pressure Compensation

CODE 11: Setting for Compensated Density Measurement

This setting defines the reference temperature and pressure required to obtain the compensated density.

(a) Setting of reference temperature [*C.D.TMP]

Configurable range: -20.0 to 80.0 (for °C)
-4.0 to 176.0 (for °F)

(b) Setting of reference pressure [*C.D.PRS]

Configurable range: 0.10 to 999.99 (for kPa),
0.0001 to 9.9999 (for MPa),
0.015 to 99.999 (for psi)

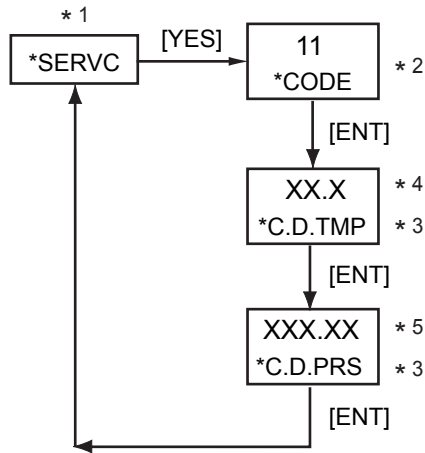

F0513.ai

- *1: See "Figure 5.3 Process at the Setting Level" on page 5-10.
- *2: Enter the code number.
- *3: Set a value using the [>], [^] and [ENT] keys.
If you enter a value that exceeds the limits, the display shows [*OVER].
Press the [YES] or [NO] key to re-set the value.
- *4: The position of the decimal point changes depending on the setting of CODE 23.
If the code is set to "0" (°C), the reading is XX.X;
if the code is set to "1" (°F), the reading is XXX.X.
- *5: The position of the decimal point changes depending on the setting of CODE 20.
If the code is set to "0" (kPa), the reading is XXX.XX;
if the code is set to "1" (MPa), the reading is X.XXXX;
if the code is set to "2" (psi), the reading is XX.XXX.

Figure 5.12 Setting for Compensated Density Measurement

CODE 12: Setting of Gas Pressure

This setting defines the zero and span points of the pressure transmitter's measurement range.

(a) Setting of zero-point gas pressure [*Z_PRS]

Configurable range: 0.01 to 999.99 (for kPa),
0.0001 to 9.9999 (for MPa),
0.015 to 99.999 (for psi)

(b) Setting of span-point gas pressure [*S_PRS]

Configurable range: 0.10 to 999.99 (for kPa),
0.0001 to 9.9999 (for MPa),
0.015 to 99.999 (for psi)

The zero and span points set here are also used for the analog output.

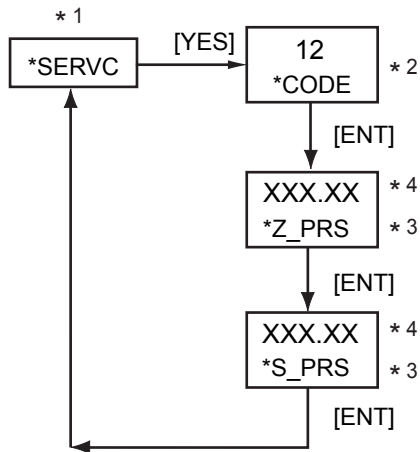

F0514.ai

- *1: See "Figure 5.3 Process at the Setting Level" on page 5-10.
- *2: Enter the code number.
- *3: Set a value using the [>], [^] and [ENT] keys.
If you enter a value that exceeds the limits, the display shows [*OVER].
Press the [YES] or [NO] key to re-set the value.
- *4: The position of the decimal point changes depending on the setting of CODE 20.
If the code is set to "0" (kPa), the reading is XXX.XX;
if the code is set to "1" (MPa), the reading is X.XXXX;
if the code is set to "2" (psi), the reading is XX.XXX.

Figure 5.13 Setting of Gas Pressure

CODE 13: Selection for Automatic Calibration [*AUTO.C]

This setting determines whether or not automatic calibration is carried out. If automatic calibration is to be carried out, you must also configure CODE 15 at the service level.

- Disable: 0
- Enable: 1

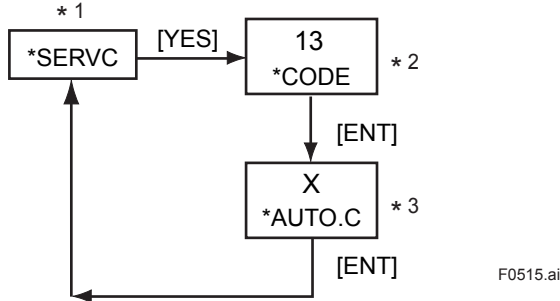

- *1: See "Figure 5.3 Process at the Setting Level" on page 5-10.
- *2: Enter the code number.
- *3: Set a value using the [>], [^] and [ENT] keys.

Figure 5.14 Selection for Automatic Calibration

CODE 14: Setting for Remote Semi-automatic Calibration [*REMOT]

This setting determines whether or not semi-automatic calibration is carried out remotely. If remote semi-automatic calibration is to be carried out, you must wire the contact input. You must also configure CODE 15 at the service level.

- Disable: 0 (The contact is open)
- Enable: 1 (The contact is closed)

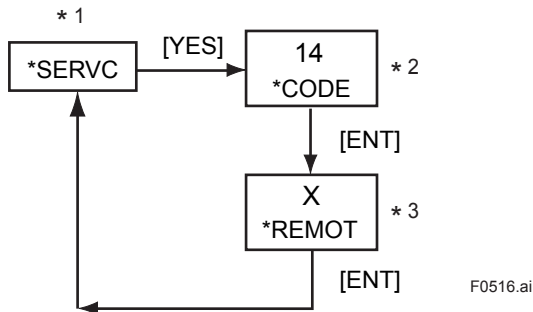

- *1: See "Figure 5.3 Process at the Setting Level" on page 5-10.
- *2: Enter the code number.
- *3: Set a value using the [>], [^] and [ENT] keys.

Figure 5.15 Setting for Remote Semi-automatic Calibration

CODE 15: Setting of Data for Automatic/Semi-automatic Calibration

This setting defines the data needed to carry out automatic/semi-automatic calibration.

- (a) Selection of calibration item [*CAL.P]
 - Zero and span: 0
 - Zero: 1
 - Span: 2
- (b) Setting of calibration time [*CAL.T]
 - Configurable range: 00 to 59 (unit : minute)
- (c) Setting of stabilization time [*STAB.T]
 - Configurable range: 00 to 59 (unit : minute)
- (d) Setting of calibration starting time
 - (1) Setting of year/month/day [*Y_M_D]
 - Configurable range: 00.01.01 to 99.12.31
 - (2) Setting of hour/minute [*H_M]
 - Configurable range: 00.00 to 23.59
- (e) Selection of unit of calibration interval [*CYCL.U]
 - Hour: 0
 - Day: 1
- (f) Selection of calibration interval [*CYCL.T]
 - Item (e) above is set to "0".
 - Configurable range: 00 to 23 (for hour)
 - Item (e) above is set to "1".
 - Configurable range: 000 to 255 (for day)

For more information, see Chapter 8, "Calibration Procedure".

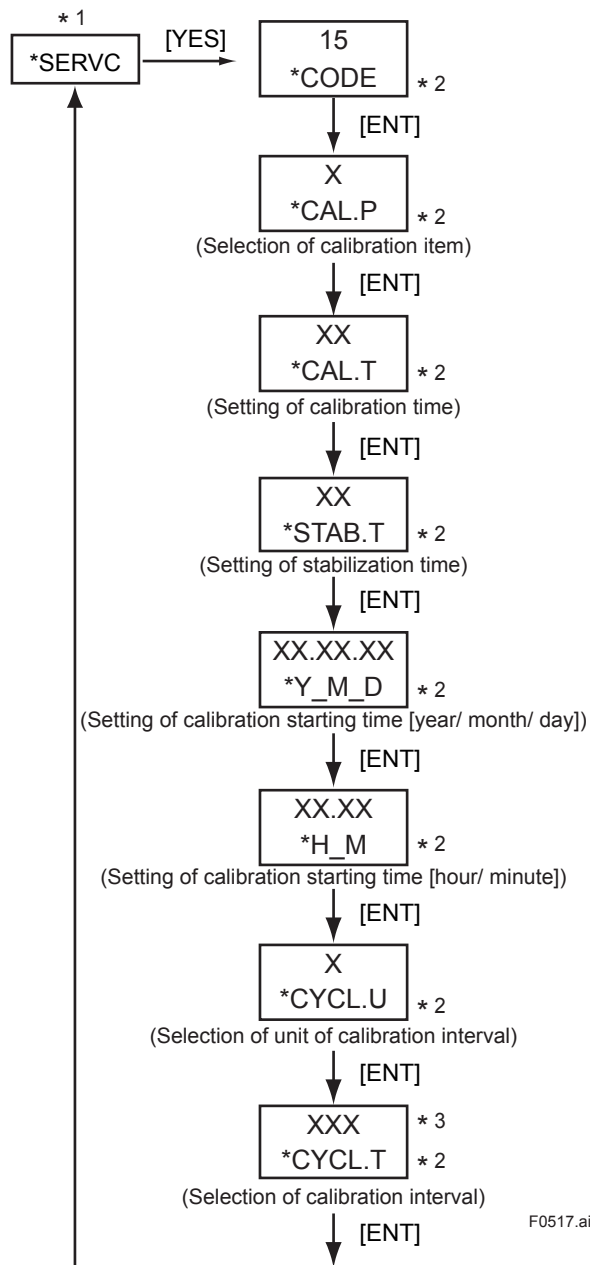

F0517.ai

*1: See "Figure 5.3 Process at the Setting Level" on page 5-10.

*2: Set a value using the [>], [^] and [ENT] keys.

If you enter a value that exceeds the limits, the display shows [*OVER].

Press the [YES] or [NO] key to re-set the value.

*3: The number of digits on LCD varies depending on the unit of the calibration interval (parameter [*CYCL.U]).

If the parameter is set to "0" (hour), the indication is two-digit number.

If the parameter is set to "1" (day), the indication is three-digit number.

Figure 5.16 Setting of Data for Automatic/Semi-automatic Calibration

CODE 20: Selection of Pressure Unit [*PRES.U]

This setting defines the pressure unit for the gas pressure transmitter.

- kPa: 0
- MPa: 1
- psi : 2

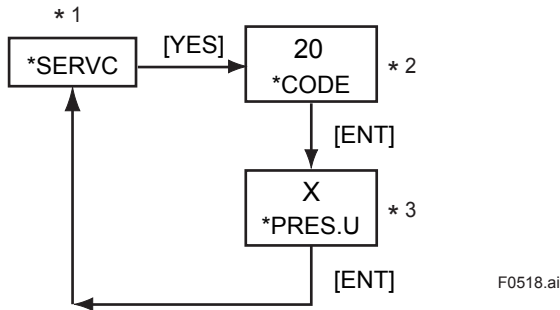

- *1: See "Figure 5.3 Process at the Setting Level" on page 5-10.
- *2: Enter the code number.
- *3: Set a value using the [>], [^] and [ENT] keys.

Figure 5.17 Selection of Pressure Unit.

CODE 21: Selection of Density Unit [*DENS.U]

This setting defines the density unit for the gas density meter.

- kg/m³: 0
- lb/ft³: 1

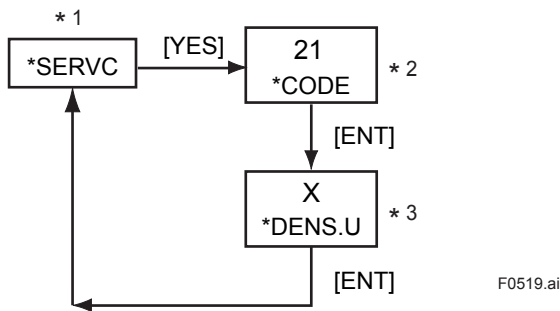

- *1: See "Figure 5.3 Process at the Setting Level" on page 5-10.
- *2: Enter the code number.
- *3: Set a value using the [>], [^] and [ENT] keys.

Figure 5.18 Selection of Density Unit

CODE 22: Selection of Calorific Value Unit [*CAL.U]

This setting defines the calorific value unit for the gas density meter.

- MJ/m³ : 0
- kBTU/ft³ : 1

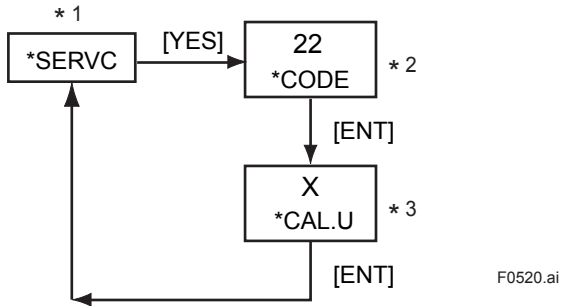

- *1: See "Figure 5.3 Process at the Setting Level" on page 5-10.
- *2: Enter the code number.
- *3: Set a value using the [>], [^] and [ENT] keys.

Figure 5.19 Selection of Calorific Value Unit

CODE 23: Selection of Temperature Unit [*TEMP.U]

This setting defines the temperature unit for the gas density meter.

- °C: 0
- °F: 1

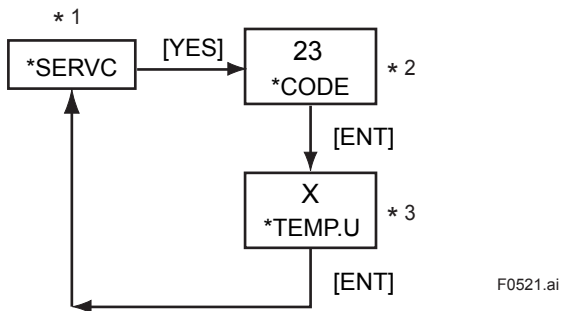

- *1: See "Figure 5.3 Process at the Setting Level" on page 5-10.
- *2: Enter the code number.
- *3: Set a value using the [>], [^] and [ENT] keys.

Figure 5.20 Selection of Temperature Unit

CODE 30: Setting of Calendar

This setting defines the date and time.

(a) Setting of year/month/day [*Y_M_D]

Configurable range : 00.01.01 to 99.12.31

(b) Setting of hour/minute [*H_M]

Configurable range : 00.00 to 23.59

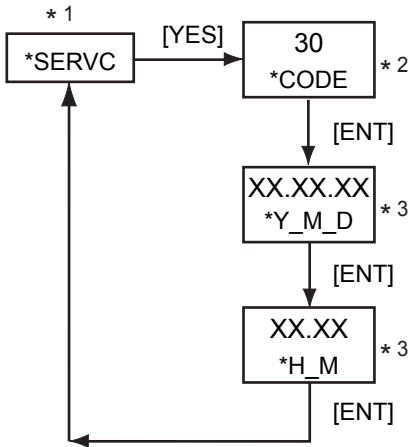

F0522.ai

*1: See "Figure 5.3 Process at the Setting Level" on page 5-10.

*2: Enter the code number.

*3: Set a value using the [>], [^] and [ENT] keys.

If you enter a value that exceeds the limits, the display shows [*OVER].

Press the [YES] or [NO] key to re-set the value.

Figure 5.21 Setting of Calendar

CODE 31: Showing/Hiding of Negative Measured Values [*MINUS]

This setting determines whether negative measured values (-) should be shown or hidden.

- Show: 0
- Hide: 1

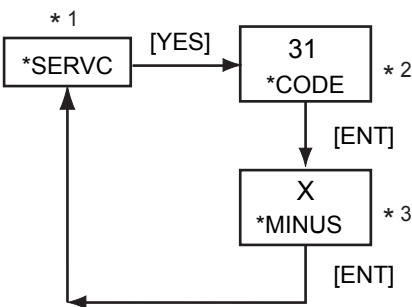

F0523.ai

*1: See "Figure 5.3 Process at the Setting Level" on page 5-10.

*2: Enter the code number.

*3: Set a value using the [>], [^] and [ENT] keys.

Figure 5.22 Showing/Hiding of Negative Measured Values

CODE 40: Indication of Calibration Coefficients (Read-only)

This setting determines the calibration coefficients to be indicated.

- (a) Zero [*C_K_Z]: indicated as SX.XXXX
- (b) Span [*C_K_S]: indicated as X.XXXX

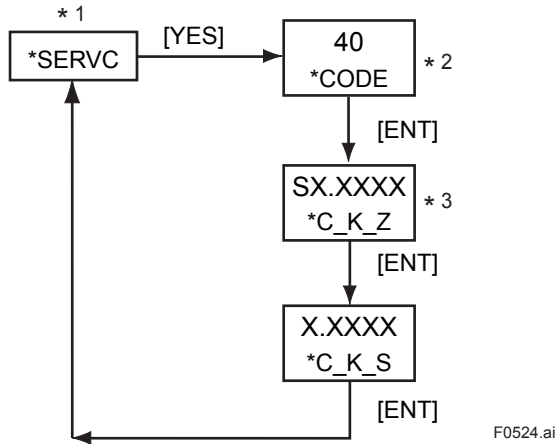

- *1: See "Figure 5.3 Process at the Setting Level" on page 5-10.
- *2: Enter the code number.
- *3: By pressing the [ENT] key, the next indication is displayed.
This parameter does not accept the [>] and [^] key input.

Figure 5.23 Indication of Calibration Coefficients

CODE 41: Indication of Oscillation Frequency (Read-only)

This setting determines the F2 and F4 oscillation frequencies coefficients to be indicated.

- (a) Indication of frequency F2 (kHz) [*F2.KHZ]: indicated as X.XXXXXX
- (b) Indication of frequency F4 (kHz) [*F4.KHZ]: indicated as X.XXXXXX
- (c) Indication of frequency ratio (kHz) [*F2/F4]: indicated as X.XXXXXX

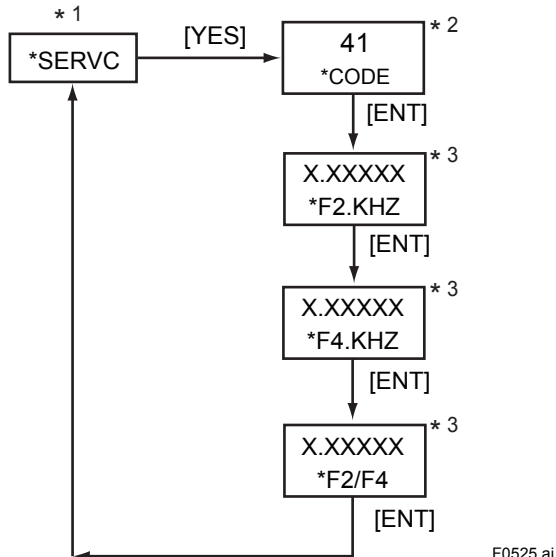

- *1: See "Figure 5.3 Process at the Setting Level" on page 5-10.
- *2: Enter the code number.
- *3: By pressing the [ENT] key, the next indication is displayed.
This parameter does not accept the [>] and [^] key input.

Figure 5.24 Indication of Oscillation Frequency

CODE 42: Indication of Software Version [*REV] (Read-only)

This setting allows the software version to be confirmed (indicated).
Indicated as X.XX

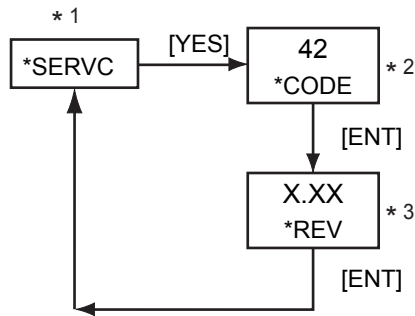

F0526.ai

- *1: See "Figure 5.3 Process at the Setting Level" on page 5-10.
- *2: Enter the code number.
- *3: Pressing the [ENT] key returns to the service level with the indication [*SERVC].
This parameter does not accept the [>] and [^] key input.

Figure 5.25 Indication of Software Version

CODE 43: Setting of High-resolution Mode [*S_CYC]

This setting selects between the normal mode and the high-resolution mode.

- Normal mode: 0
- High-resolution mode: 1

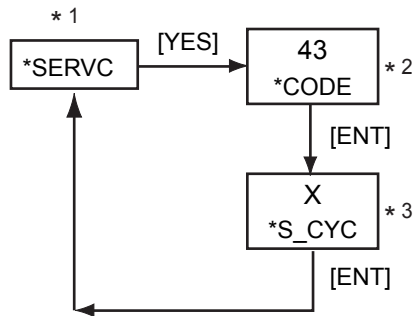

F0527.ai

- *1: See "Figure 5.3 Process at the Setting Level" on page 5-10.
- *2: Enter the code number.
- *3: Set a value by using the [>] and [^] key.

Figure 5.26 Setting of High-resolution Mode

CODE 44: Setting of PASSWORD [*PASS]

This setting defines the password.

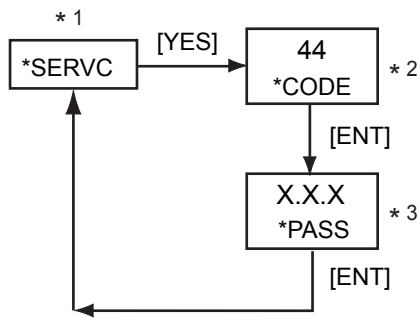

F0528.ai

*1: See "Figure 5.3 Process at the Setting Level" on page 5-10.

*2: Enter the code number.

*3: Set a value by using the [>], [^] and [ENT] keys.

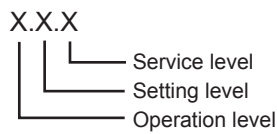

Note: Password entry request (if a password is set)

At the operation level, a request is issued when the [MODE] key is pressed in the measurement mode. At the setting level, it is issued when the [*] key is pressed. At the service level, it is issued when the [YES] key is pressed with [*SERVC] displayed.

Password	
X (Setting)	Contents
(0)	(No setting)
1	111
2	333
3	777
4	888
5	123
6	957
7	331
8	546
9	847

Figure 5.27 Setting of Password

CODE 45: Selecting Battery alarm detection [*BAT]

This setting determines whether or not battery alarm is detection.

- Non detection: 0
- Detection: 1

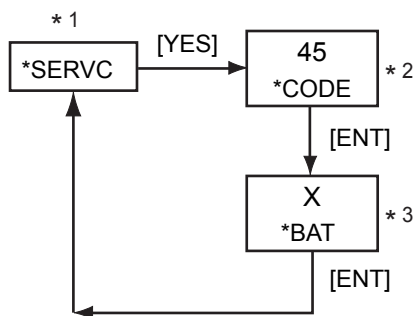

F0529.ai

*1: See "Figure 5.3 Process at the Setting Level" on page 5-10.

*2: Enter the code number.

*3: Set a value by using the [>], [^] and [ENT] keys.

Figure 5.28 Selecting Battery alarm detection

CODE 50: Selecting the instruments [*MODEL]

This setting defines the model.

- Density meter: 0
- Calorie meter: 1
- Hydrogen purity, replacement meter : 2

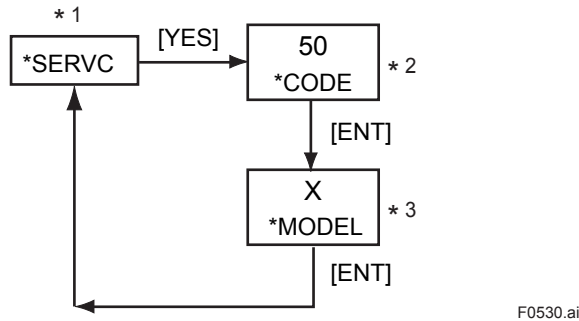

*1: See "Figure 5.3 Process at the Setting Level" on page 5-10.

*2: Enter the code number.

*3: Set a value by using the [>], [^] and [ENT] keys.

Figure 5.29 Selecting the instruments

CODE 82: Setting Detector Constant

This setting defines the detector constant.



CAUTION

The instruments may not only work improperly but also big problems occur unless the detector constants entered incorrectly. Do carefully and precisely when enter the detector constants into converter.

1. The GD402 gas density meter is shipped after adjusting the detector and converter in pairs. When installation, confirm the converter serial number described on the label of detector so that combines converter and detector correctly. If mismatched in pairs, converter may be out of order. If combined correctly, no need to enter the detector constants again, as converter has been adjusted with the constants in factory.
2. When supply converter or detector individually, enter the detector constants, described on inside the lid of the GD40, into the converter so that the GD402 is going to be well.

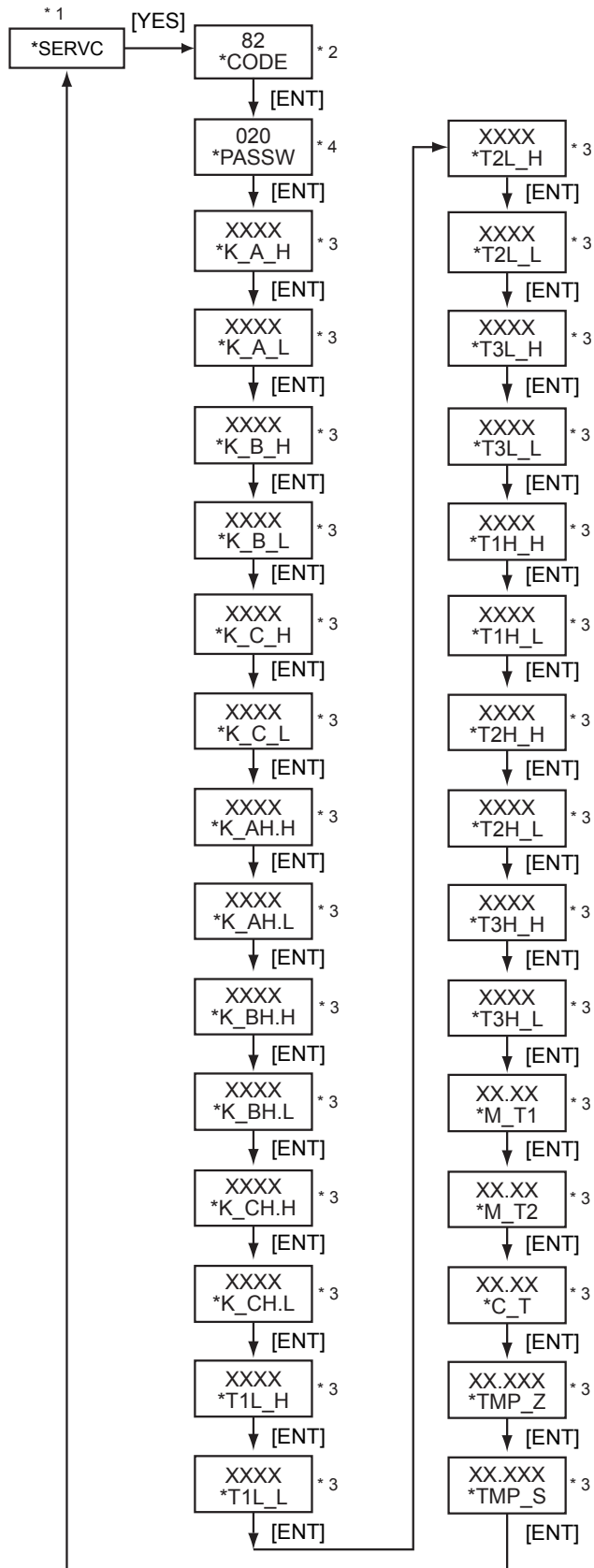

F0531.ai

- *1: See "Figure 5.3 Process at the Setting Level" on page 5-10.
- *2: Enter the code number.
- *3: Set a value using the [>], [^] and [ENT] keys.
Detector Constants are described inside the lid of detector GD40.
- *4: Set the PASSWORD.

Figure 5.30 Setting Detector Constant

6. CALORIE / PARAMETER SETTING

CAUTION

Password is not selected in first condition. When password is necessary, refer to Section "4.2 Setting Lists".

This chapter describes how to set parameters of Calorie meter.

If select Density meter, see Chapter 5.

If select Hydrogen purity meter, see Chapter 7.

Conversion Table

1 lb/ft ³	= 16.01847 kg/m ³
1 kBTU/ft ³	= 37.25901232 MJ/m ³
X degF	= (X-32)/1.8
1 psi	= 6.894756794 kPa
Density of Air	= 1.2928 kg/m ³
	= 0.08070684 lb/ft ³

6.1 Setting Parameters

Subsections 6.1.1 to 6.1.4 show the setting parameters for each level.

6.1.1 Setting Parameters at Measurement Level

When turned on, the analyzer starts up in the measurement mode (<MEASURE>).

Table 6.1 Setting Parameters at Measurement Level

Mode/Setting parameter	Display	Data to be Set (or Conditions)	Remarks
Measurement mode			See Figure 6.3 for key operation.
Indication of measurement value			
Physical density	KG/M3 LB/FT3	Set the unit in CODE 21.	
Compensated density	KG/M3 LB/FT3	Set the unit in CODE 21.	
Calorific value	MJ/M3 KBTU	Set the unit in CODE 22.	
Indication of message			
Unit			The unit is the one set in the service level.
Error symbol and number	ERR.NO		Appears if an error occurs.
Alarm mark and number	ALM.NO		Appears if an alarm occurs.
Indication of HOLD and FAIL			Appears even during other modes.
HOLD	HOLD		Appears during a HOLD state.
FAIL	FAIL		Appears if a failure occurs.
DISP mode	DISP		See Figure 6.3 for key operation.
Physical density	KG/M3 LB/FT3	Set the unit in CODE 21.	Selection of parameters to be measured in the measurement mode.
Compensated density	KG/M3 LB/FT3	Set the unit in CODE 21.	
Calorific value	MJ/M3 KBTU	Set the unit in CODE 22.	
Sample gas temperature	°C °F	Set the unit in CODE 23.	Read-only
Sample gas pressure	KPA MPA PSI	Set the unit in CODE 20.	Read-only
Analog output 1 (%)	MA1%		Read-only
Analog output 2 (%)	MA2%		Read-only

6.1.2 Setting Parameters at Operation Level

Press the [MODE] key and enter the password (XXX) to gain access to this level (see Figure 6.1 for key operation).

Table 6.2 Setting Parameters at Operation Level

Mode/Setting parameter	Display	Data to be Set (or Conditions)	Remarks
Calibration mode Semi-automatic calibration Manual calibration Setting of zero-point calorific value Setting of zero-point density Setting of span-point calorific value Setting of span-point density	SEM.CAL MAN.CAL Z_CAL Z_DNS S_CAL S_DNS	One-touch calibration	See Figure 9.3 for key operation. See Figure 9.4 for key operation.
Zero/span-gas valve operation Zero-gas valve operation Span-gas valve operation Sample-gas valve operation	VALVE	No setting is required for manual calibration. Control of zero-gas valve Control of span-gas valve Switching between sample and calibration gases	See Figure 9.1 for key operation.
Density/calorie conversion factor setting mode Automatic zero-point adjustment Factor setting Zero point Factor K0 Factor K1	ADJUST AT_ADJ SET_K K0_ADJ K0 K1	The decimal point can be repositioned for this setting only. Range : -99999 to 99999 Range : -99999 to 99999 Range : 0 to 99999	See Figure 6.2 for key operation. (Floating-point)

6.1.3 Setting Parameters at Setting Level

Press the [*] key and enter the password (XXX) to gain access to this level (see Figure 6.5 for key operation).

Table 6.3 Setting Parameters at Setting Level

Mode/Setting parameter	Display	Data to be Set (or Conditions)	Remarks
Analog output setting Output 1 Set a parameter to be output Set the zero and span points Physical density Compensated density Calorific value Output 2 (same as output 1)	*RANGE *OUT1 *DENS *C_DNS *CALRY *TEMP *PRESS *Z_DNS, *S_DNS *Z_CP.D, *S_CP.D *Z_CAL, *S_CAL *OUT2	Physical density Compensated density Calorific value Gas temperature Gas pressure 00.0000 to 60.0000 kg/m ³ 0.00000 to 4.00000 lb/ft ³ 0.0000 to 6.0000 kg/m ³ 0.00000 to 0.40000 lb/ft ³ 000.000 to 133.000 MJ/m ³ 0.0000 to 3.5000 kBTU/ft ³	See Figure 6.5 for key operation. No setting is required if the parameter is temperature or pressure.
Setting calibration data Zero-point calorific value Zero-point density Span-point calorific value Span-point density Output hold value during calibration Setting of preset value (Only if the preceding parameter is set to 2 (preset value))	*CAL.DT *Z_CAL *Z_DNS *S_CAL *S_DNS *C_HLD *PR.SET	000.000 to 133.000 MJ/m ³ 0.0000 to 6.0000 kg/m ³ 0.00000 to 0.40000 lb/ft ³ 000.000 to 133.000 MJ/m ³ 0.0000 to 3.5000 kBTU/ft ³ 0.0000 to 6.0000 kg/m ³ 0.00000 to 0.40000 lb/ft ³ · Disable: 0 · Enable (value immediately before) : 1 · Enable (preset value) : 2 -10.0 to 110.0	See Figure 9.2 for key operation.
Alarm-point setting Select a parameter for which an alarm is set Physical density Compensated density Calorific value Set the high/low limits. Physical density Compensated density Calorific value	*ALARM *DENS *C_DNS *CALRY *L_DNS, *H_DNS *L_CP.D, *H_CP.D *L_CAL, *H_CAL	00.0000 to 60.0000 kg/m ³ 0.0000 to 6.0000 kg/m ³ 000.000 to 133.000 MJ/m ³	See Figure 6.6 for key operation.

6.1.4 Setting Parameters at Service Level

Press the [*] key and enter the password (XXX) to select the service level. When you select this level, the analyzer shows a Code No. promptly. Type the appropriate code number and press the [ENT] key.

Table 6.4 Setting Parameters at Service Level

Code No.	Item	Display	Data to be Set (or Conditions)	Remarks
01	Setting of hold during maintenance Hold enable/disable	*M_HLD	· Disable : 0 · Enable (value immediately before) : 1	See Figure 6.8 for key operation. If "preset value" is selected in the preceding parameter.
	Setting of preset hold value	*PR.SET	· Enable (preset value) : 2 -10.0 to 110.0	
02	Setting of hold against errors Hold enable/disable	*E_HLD	· Disable : 0 · Enable (value immediately before) : 1	See Figure 6.9 for key operation. If "preset value" is selected in the preceding parameter.
	Setting of preset hold value	*PR.SET	· Enable (preset value) : 2 -10.0 to 110.0	
04	Setting of output-smoothing constants	*SMOTH	00 to 60	See Figure 6.10 for key operation.
05	Setting of contact outputs status	*CNTCT	00 to 15	See Figure 6.11 for key operation.
10	Setting of pressure compensation Enable/disable/fixed value	*P.COMP	· Disable: 0 · Enable (measured value) : 1 · Enable (fixed value) : 2	See Figure 6.12 for key operation. If "fixed value" is selected in the preceding parameter.
	Setting of fixed value for pressure compensation	*P.FIX	0.10 to 999.99 kPa, 0.0001 to 9.9999 MPa, 0.015 to 99.999 psi	
11	Setting for compensated density measurement			See Figure 6.13 for key operation.
	Setting of reference temperature Setting of reference pressure	*C.D.TMP *C.D.PRS	-20.0 to 80.0°C, -4.0 to 176.0°F 0.10 to 999.99 kPa, 0.0001 to 9.9999 MPa, 0.015 to 99.999 psi	
12	Setting of gas pressure			See Figure 6.14 for key operation.
	Setting of zero-gas pressure Setting of span-gas pressure	*Z_PRS *S_PRS	0.01 to 999.99kPa, 0.0001 to 9.9999MPa, 0.015 to 99.999 psi 0.10 to 999.99kPa, 0.0001 to 9.9999MPa, 0.015 to 99.999 psi	
13	Selection for automatic calibration	*AUTO.C	· Disable : 0 · Enable : 1	See Figure 6.15 for key operation.
14	Setting for remote semi-automatic calibration	*REMOT	· Disable : 0 · Enable : 1	See Figure 6.16 for key operation.
15	Setting of data for automatic/semi-automatic calibration			See Figure 6.17 for key operation.
	Selection of calibration item	*CAL.P	Zero and span : 0 Zero : 1 Span : 2	
	Setting of calibration time	*CAL.T	00 to 59	
	Setting of stabilization time	*STAB.T	00 to 59	
	Setting of calibration starting time			
	Setting of year/month/day	*Y_M_D	00.01.01 to 99.12.31	
Setting of hour/minute	*H_M	00.00 to 23.59		
Selection of unit of calibration interval	*CYCL.U	Hour : 0 Day : 1		
Selection of calibration interval	*CYCL.T	Hour : 00 to 23 Day : 000 to 255		

Table 6.4 Setting Parameters at Service Level

Code No.	Item	Display	Data to be Set (or Conditions)	Remarks
20	Selection of pressure unit	*PRES.U	· kPa : 0 · MPa : 1 · psi : 2	See Figure 6.18 for key operation.
21	Selection of density unit	*DENS.U	· kg/m ³ : 0 · lb/ft ³ : 1	See Figure 6.19 for key operation.
22	Selection of calorific value unit	*CAL.U	· MJ/m ³ : 0 · kBTU/ft ³ : 1	See Figure 6.20 for key operation.
23	Selection of temperature unit	*TEMP.U	· °C : 0 · °F : 1	See Figure 6.21 for key operation.
30	Setting of calendar Setting of year/month/day Setting of hour/minute	*Y_M_D *H_M	00.01.01 to 99.12.31 00.00 to 23.59	See Figure 6.22 for key operation. For leap years, the setting can cope with 'February 29'.
31	Showing/hiding of negative measured values (-)	*MINUS	· Show : 0 · Hide : 1	See Figure 6.23 for key operation.
40	Indication of calibration coefficients (read-only) Zero Span	*C_K_Z *C_K_S	SX.XXXX X.XXXX	See Figure 6.24 for key operation. S of SX.XXXX means Marks such as a plus or the minus.
41	Indication of oscillation frequency (read-only) Frequency F2 Frequency F4 Frequency ratio	*F2.KHZ *F4.KHZ *F2/F4	X.XXXXX X.XXXXX X.XXXXX	See Figure 6.25 for key operation.
42	Indication of software version (read-only)	*REV	X.XX	See Figure 6.26 for key operation.
43	Setting of high-resolution mode	*S_CYC	· Normal : 0 · High-resolution : 1	See Figure 6.27 for key operation.
44	Setting of password	*PASS	0.0.0 to 9.9.9	See Figure 6.28 for key operation.
45	Selecting Battery alarm detection	*BAT	· Non detection : 0 · Detection : 1	See Figure 6.29 for key operation.
50	Selecting the instruments	*MODEL	· Density meter : 0 · Calorie meter : 1 · Hydrogen purity, replacement meter : 2	See Figure 6.30 for key operation.
82	Setting Detector Constant			See Figure 6.31 for key operation.

6.2 Parameter Setting

[Aborting the Setting Operation]

Press the [MODE] key. Normally, the [MODE] key is used to move from the measurement (<MEASURE>) mode to a mode at the operation level. It is also used to return to the measurement mode from other modes.

6.2.1 Parameter Setting at Operation Level

To move to the operation level, press the [MODE] key and then enter the password (XXX). Password is not selected in first condition. When password is necessary, refer to Section 4.2 "Setting Lists" and selected password what you need.

The operation level offers two mode categories: the measurement and calibration operation modes.

Note that the function for which you have set a data value at the setting level does not work at all if that function is turned off at another level. For this reason, care must be taken when dealing with modes that relate to each other.

This subsection explains the operating procedures for the levels/modes noted below. The calibration operation mode is discussed in Chapter 9.

- (1) Operation level
- (2) Density/calorie conversion factor setting mode
- (3) Display mode (DISP mode)

(1) Operation Level

Select a mode from the following four choices of the operation level. Each press of the [NO] key cycles through the choices in the order shown below:

- 1. Display mode [DISP]
- 2. Semi-automatic calibration mode [SEM.CAL]
- 3. Manual calibration mode [MAN.CAL]

In the mode, "Density / Calorie Conversion Factor Setting Mode" is included in next page.

- 4. Valve operation mode [VALVE]

Press the [YES] key to enter the desired mode when it is indicated.

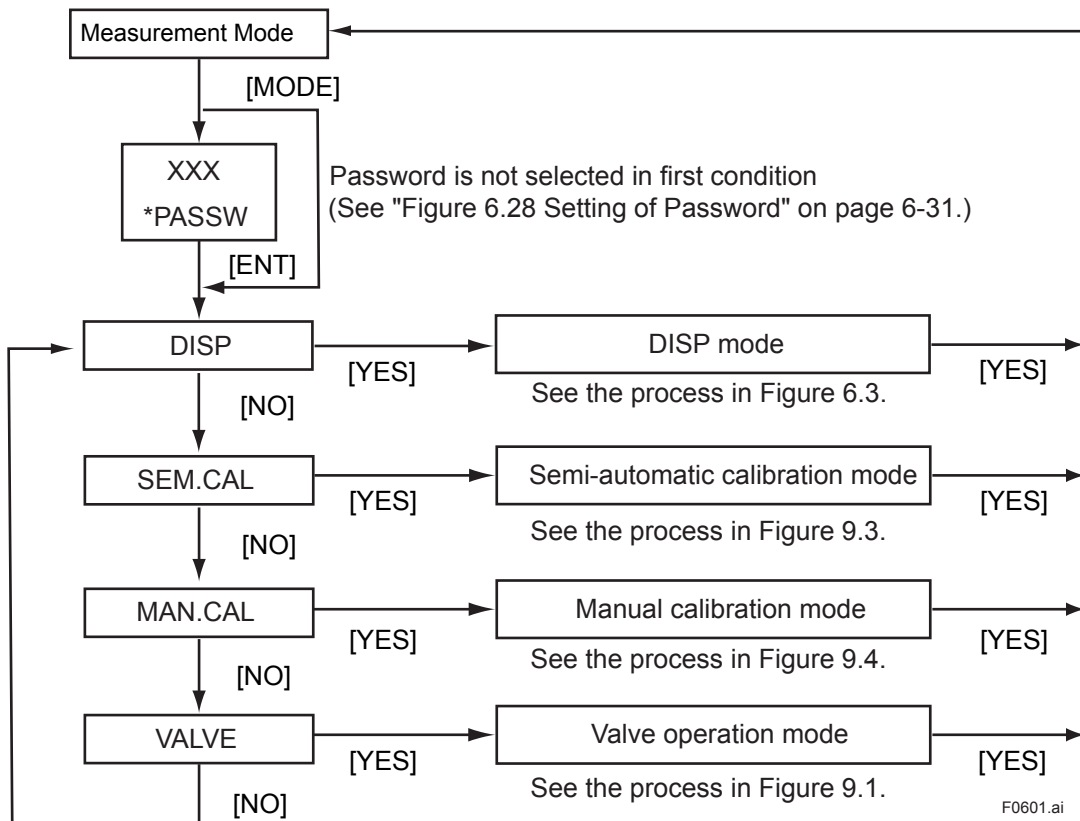

You can abort the setting operation in any of the modes by pressing [MODE] key. Doing this will return the analyzer to the measurement mode.

Figure 6.1 Modes of Operation Level

(2) Density/Calorie Conversion Factor Setting Mode

In order to this mode, select "MAN.CAL" in before page, and press [YES] key. This mode is used to set a factor for converting density to calorie. This setting is mandatory when measuring the calorie.

(a) Automatic zero-point adjustment [AT_ADJ] : 0 to 133.000, 0 to 3.5000

(b) Factor setting [SET_K] :

- Zero point [K0_ADJ] : -99999 to 99999
- K0 [K0] : -99999 to 99999
- K1 [K1] : 0 to 99999

Note: The result of executing item (a) above is also reflected on [K0_ADJ] in item (b).

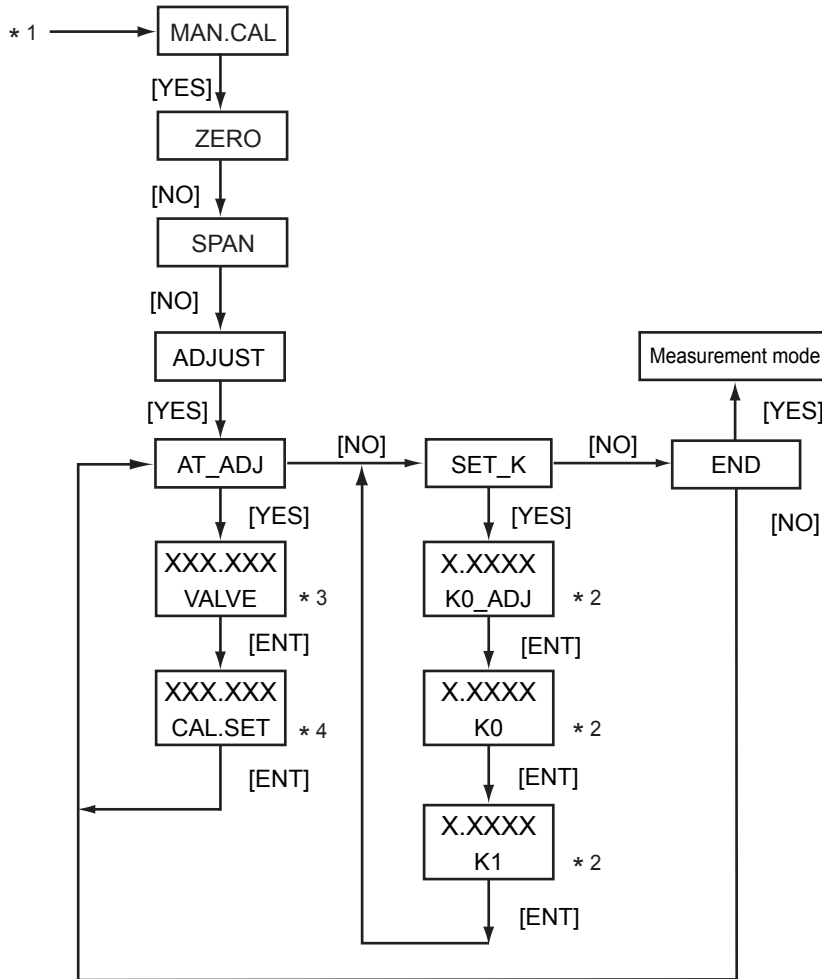

*1: See "Figure 6.1 Modes of Operation Level" on page 6-8.
 *2: Using the [>], [^] and [ENT] keys, set a value (numeral position of the decimal point and sign). Each press of the [>] key moves through the fields of the numeral decimal point and sign in this order. If you enter a value that exceeds the limits, the display shows [*OVER]. Press the [YES] or [NO] key to re-set the value.
 *3: Set a value using the [>], [^] and [ENT] keys.
 *4: When the reading stabilizes, press the [ENT] key to confirm the factor. This parameter does not accept input from the [>] and [^] keys.

F0602.ai

Figure 6.2 Density / Calorie Conversion Factor Setting Mode

(3) Display Mode

Select one of the following seven parameters to be shown in the message field. Each press of the [NO] key cycles through the choices in the order shown below:

1. Physical density [XX.XXXX KG/M3] or [XX.XXXX LB/FT3]
(depends on the setting of CODE 21)
2. Compensated density [X.XXXX KG/M3] or [X.XXXXX LB/FT3]
(depends on the setting of CODE 21)
3. Calorific value [XXX.XXX MJ/M3] or [XX.XXXX KBTU]
(depends on the setting of CODE 22)
4. Temperature [XXX.X °C] or [XXX.X °F]
(depends on the setting of CODE 23)
5. Pressure [XXX.XX KPA] or [X.XXXX MPA] or [XX.XXX PSI]
(depends on the setting of CODE 20)
6. Current for analog output 1 (%) [XXX.X MA1%]
7. Current for analog output 2 (%) [XXX.X MA2%]

Show the desired choice and press the [YES] key. That choice is set as a parameter to be measured in the measurement mode (<MEASURE>). Parameters 1, 2 and 3 are configurable, while parameters 4 to 7 are read-only.

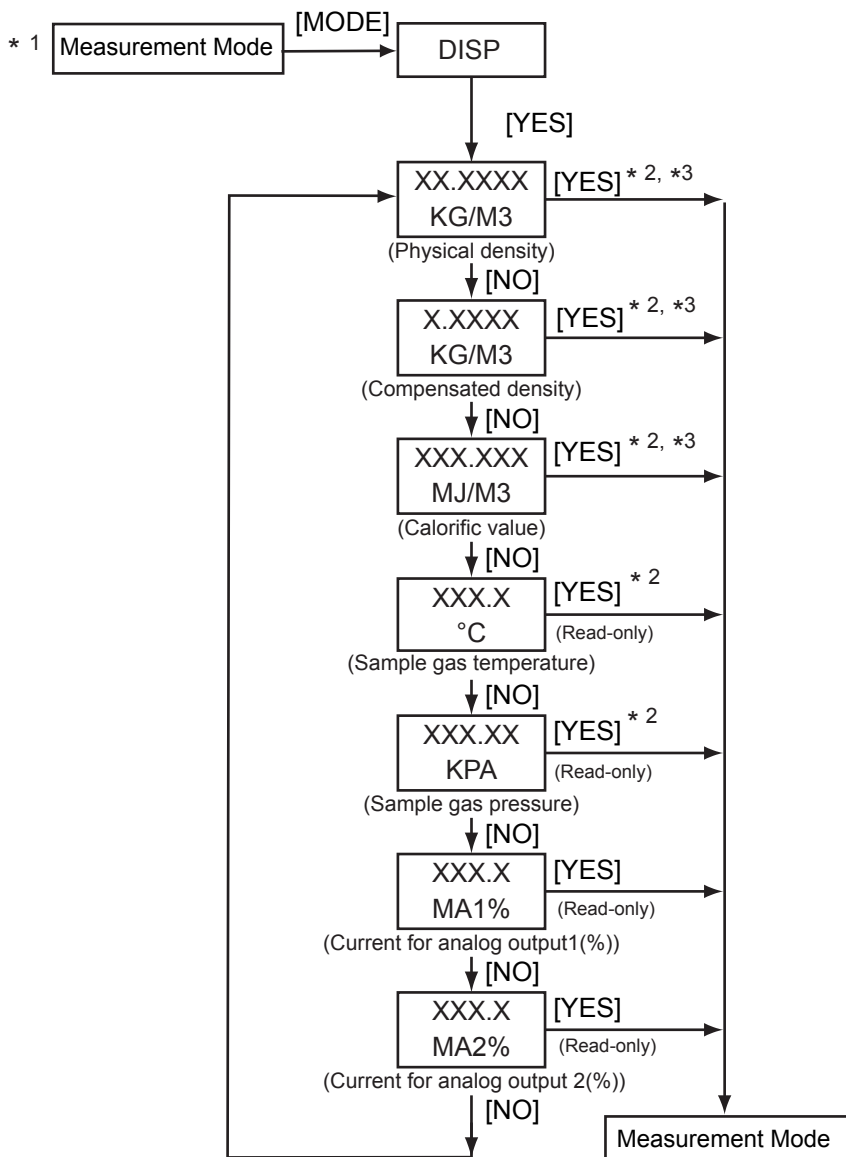

F0603.ai

- *1: See "Figure 6.1 Modes of Operation Level" on page 6-8.
- *2: The unit is the one set the service level.
- *3: Press the [YES] key to show the parameter in the measurement mode.

Figure 6.3 Display Mode (DISP Mode)

6.2.2 Parameter Setting at Setting Level

To move to the setting level, press the [*] key and then enter the password (XXX). The main task at the setting level is to set data values such as the measuring range values.

Note that the function for which you have set data values at the setting level, will not work if that function is turned off at another level. For this reason, care must be taken when dealing with modes that relate to each other. The setting level has four levels/modes, as shown below, although this subsection explains only the analog output setting and alarm-point setting modes. The calibration parameter setting mode is discussed in Chapter 9.

1. Analog output setting mode [*RANGE]
2. Calibration parameter setting mode [*CAL.DT]
3. Alarm-point setting mode [*ALARM]
4. Service level [*SERVC]

Select a mode from the above four choices. Each press of the [NO] key cycles through the choices in sequence. Press the [YES] key to enter the desired mode when it is indicated.

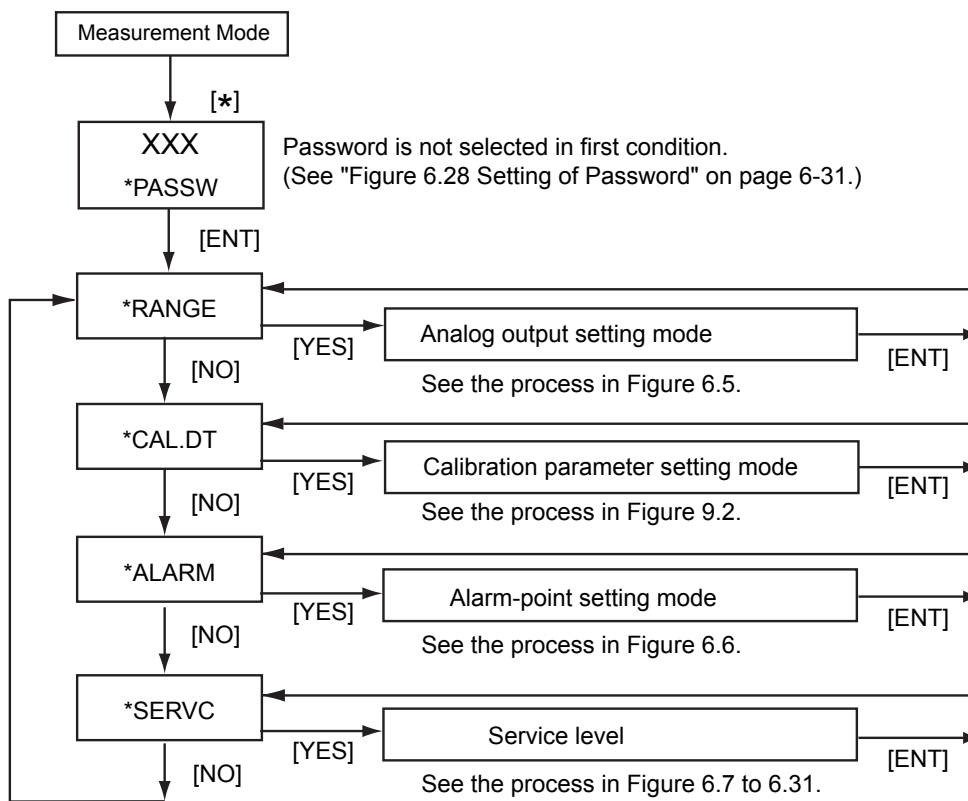

F0604.ai

You can abort the setting operation in any of the modes by pressing the [MODE] key. Doing this will return the analyzer to the measurement mode.

Figure 6.4 Process at the Setting Level

1. Analog Output Setting Mode [*RANGE]

The analog output has output 1 and output 2. Only output 1 can be used for communication purposes.

Set a range appropriate for 4-20 mA DC output signals. The range has two setpoints: the lower limit (zero point) of the range corresponding to the minimum (0%) of a given output signal and the upper limit (span point) of the range corresponding to the maximum (100%) of the given output signal.

(1) Output 1 [*OUT1]

(a) Select a parameter to be output.

- Physical density [*DENS]
- Compensated density [*C_DNS]
- Calorific value [*CALRY]
- Gas temperature [*TEMP]
- Gas pressure [*PRESS]

(b) Set the zero and span points. (This item is not applied if temperature or pressure are chosen as the parameter in item (a) above.)

- Physical density [*Z_DNS], [*S_DNS]
Configure range: 00.0000 to 60.0000 (kg/m³),
 0.00000 to 4.00000 (lb/ft³)
- Compensated density [*Z_CP.D], [*S_CP.D]
Configure range: 0.0000 to 6.0000 (kg/m³),
 0.00000 to 0.40000 (lb/ft³)
- Calorific value [*Z_CAL], [*S_CAL]
Configure range: 000.000 to 133.000(MJ/m³),
 0.0000 to 3.5000 (kBTU/ft³)

(2) Output 2 [*OUT2]

The same parameters as those of item (1) apply.

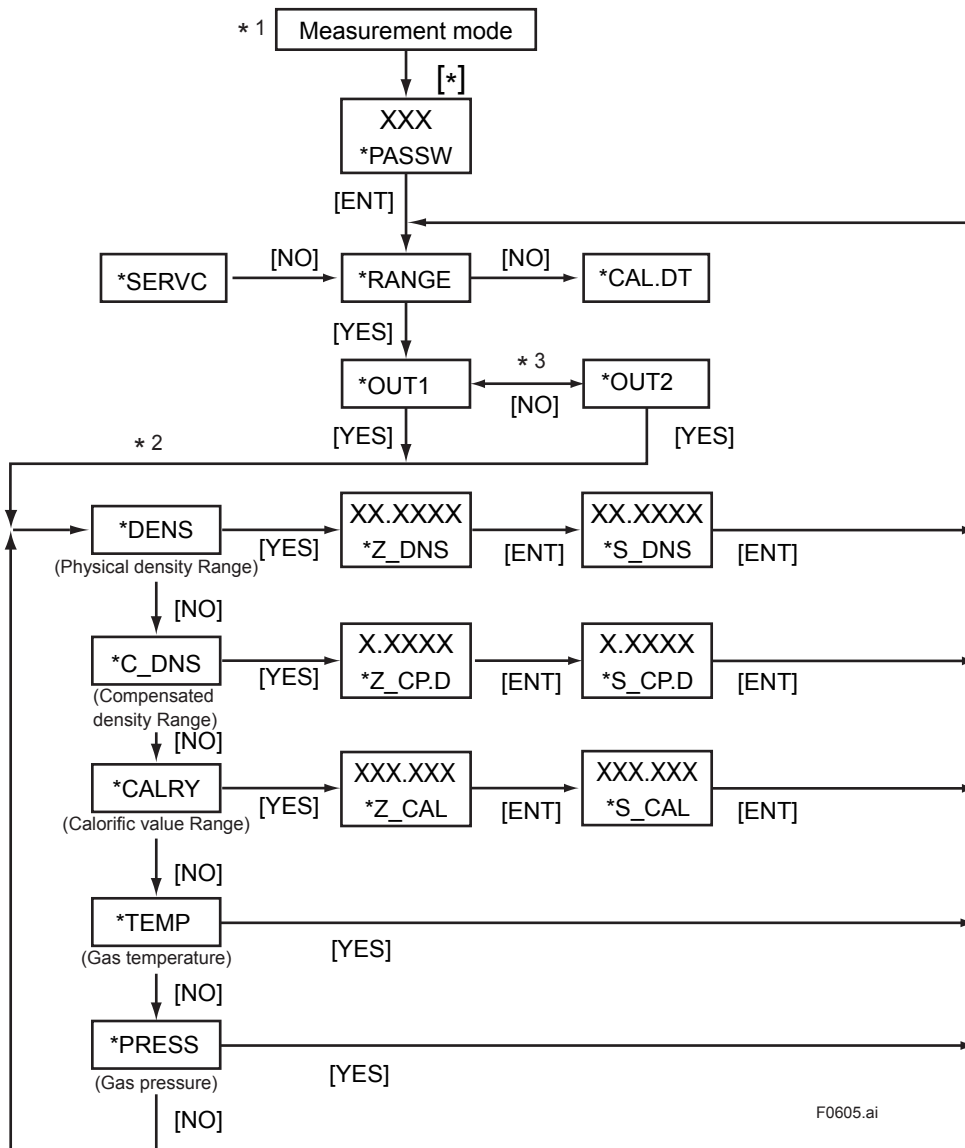

*1: You can abort the setting operation in any of the modes by pressing [MODE] key.

Doing this will return the analyzer to the measurement mode.

*2: The display shows the previous parameter first.

*3: Each press of the [NO] key toggles between the parameters [*OUT1] and [*OUT2].

Figure 6.5 Process of the Analog Output Setting Mode

2. Alarm-point Setting Mode [*ALARM]

Set the upper /lower limits for the measured values of the parameters noted below, for the purpose of raising an alarm.

(a) Select a parameter for which alarms are raised.

- Physical density [*DENS]
- Compensated density [*C_DNS]
- Calorific value [*CALRY]

Press the [YES] key to enter the desired mode when it is indicated.

(b) Set the upper/lower limits.

- Physical density [*L_DNS], [*H_DNS]
Configure range: 00.0000 to 60.0000 (kg/m³),
0.00000 to 4.00000 (lb/ft³)
- Compensated density [*L_CP.D], [*H_CP.D]
Configure range: 0.0000 to 6.0000 (kg/m³),
0.00000 to 0.40000 (lb/ft³)
- Calorific Value [*L_CAL], [*H_CAL]
Configure range: 000.000 to 133.000 (MJ/m³),
0.0000 to 3.5000 (kBTU/ft³)

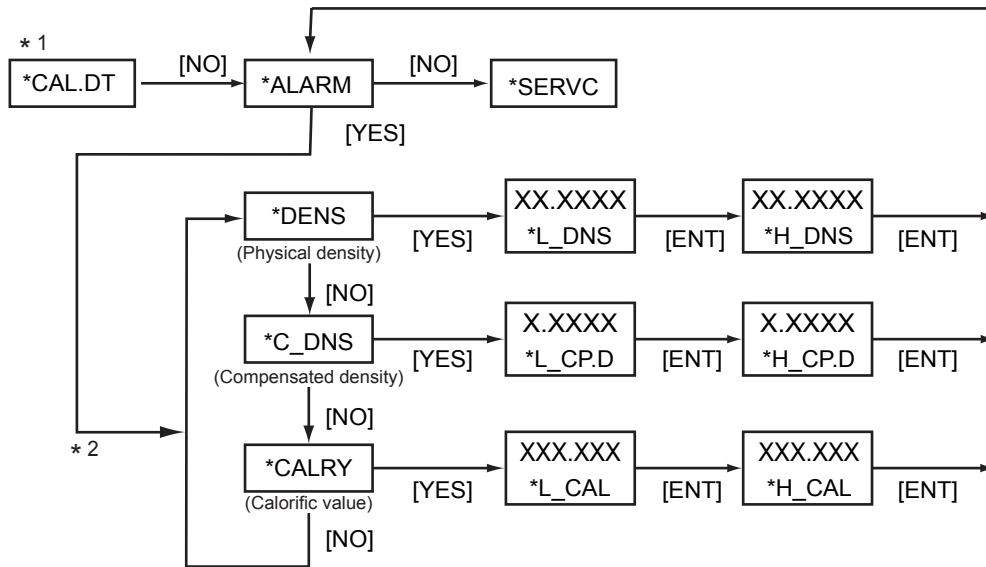

*1: See "Figure 6.4 Process at the Setting Level" on page 6-12.

*2: The display shows the previous parameter first.

F0606.ai

Figure 6.6 Process of the Alarm-point Setting Mode

6.2.3 Parameter Setting at Service Level

To move to the service level, select [*SERVC] at the setting level, and press the [YES] key. (see Figure 6.4 on page 6-12.) The main task at the setting level is to set data values such as a measuring range. To go into each mode of the service level, enter the appropriate code number.



CAUTION

DO NOT enter codes other than those listed in Table 6.4. A change to the settings of any unlisted code can result in the failure of the analyzer to operate properly. If you have entered a wrong code number by mistake, press the [MODE] key to return to the measurement mode(<MEASURE>). You may exit the mode of that wrong code by pressing the [ENT] key, if you haven't made any change to the relevant data.

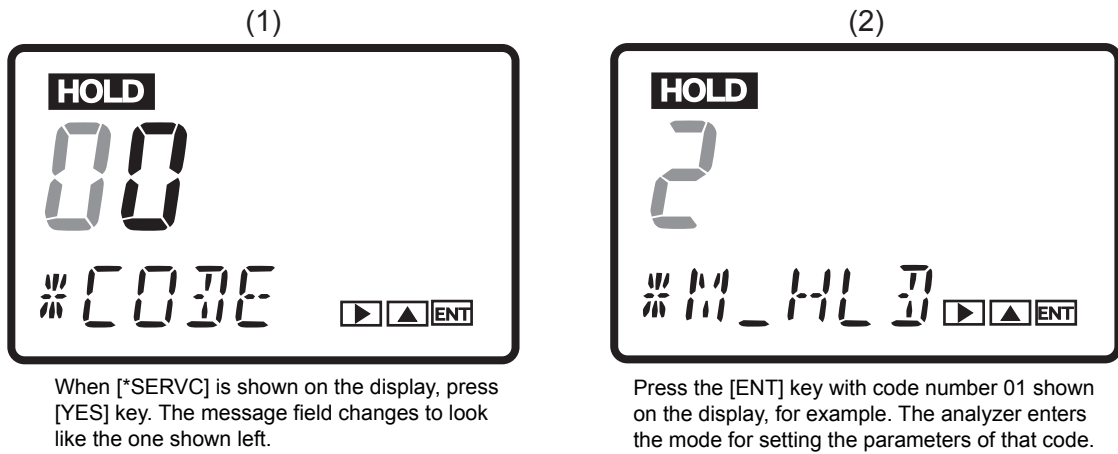

0607.ai

Figure 6.7 Entry of Code Number at Service Level

The following explains the parameter setting procedures in the order of code numbers.

CODE 01: Setting of Hold during Maintenance

This setting determines whether or not the output signal is held during maintenance. As a value to be held, you can select either a value immediately before or a preset value.

(a) Hold enable/disable [*M_HLD]

- Disable: 0
- Enable: 1
- Enable (preset value): 2

(b) Setting of preset hold value [*PR.SET]

This item applies if item (a) above is set to "2".

Configurable range: -10.0 to 110.0 (percent of analog output)

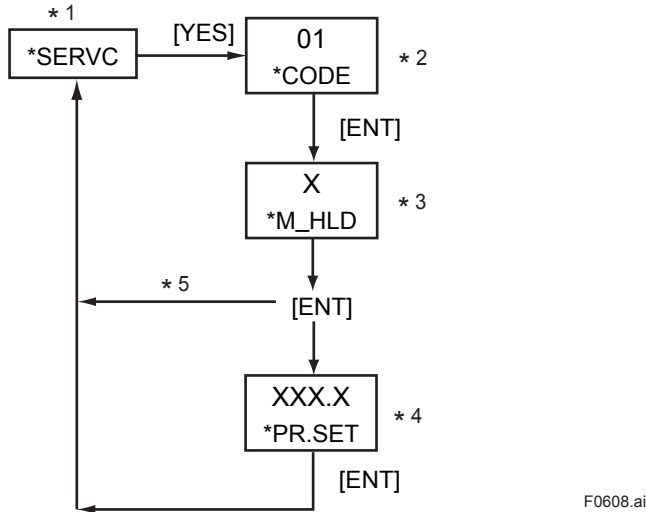

- *1: See "Figure 6.4 Process at the Setting Level" on page 6-12.
- *2: Enter the code number.
- *3: Set a value using the [^] and [ENT] keys.
- *4: Set a value using the [>], [^] and [ENT] keys.
If you enter a value that exceeds the limits, the display shows [*OVER].
Press the [YES] or [NO] key to re-set the value.
- *5: Setting 0 or 1 returns to the service level with the indication [*SERVC].

Figure 6.8 Setting of Hold during Maintenance

CODE 02: Setting of Hold in the Event of Errors

This setting determines whether or not the output signal is held if an error occurs. You can select either the value immediately prior to the error or a preset value as the value to be held.

(a) Hold enable/disable [*E_HLD]

- Disable: 0
- Enable: 1
- Enable (preset value): 2

(b) Setting of preset hold value [*PR.SET]

This item applies if item (a) above is set to "2".

Configurable range: -10.0 to 110.0 (percent of analog output)

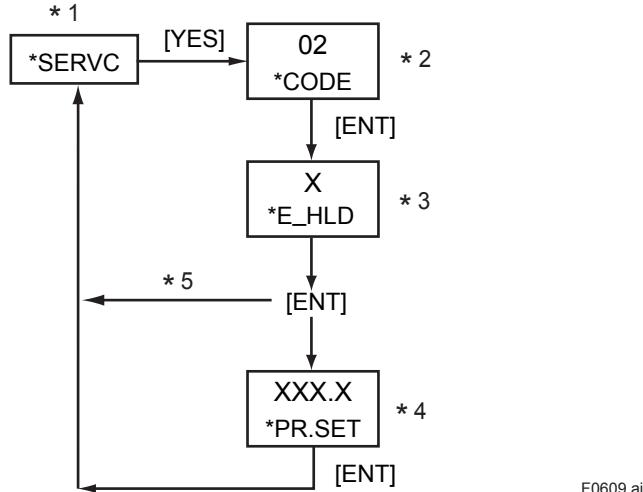

- *1: See "Figure 6.4 Process at the Setting Level" on page 6-12.
- *2: Enter the code number.
- *3: Set a value using the [^] and [ENT] keys.
- *4: Set a value using the [>], [^] and [ENT] keys.
If you enter a value that exceeds the limits, the display shows [*OVER].
Press the [YES] or [NO] key to re-set the value.
- *5: Setting 0 or 1 returns to the service level with the indication [*SERVC].

Figure 6.9 Setting of Hold in the Event of Error

CODE 04: Setting of Output-smoothing Constants [*SMOTH]

This setting defines the constants for output smoothing.

This smoothing constants is output-smoothing constants of converter (electrical circuit boards).

Configurable range: 00 to 60 (unit : second)

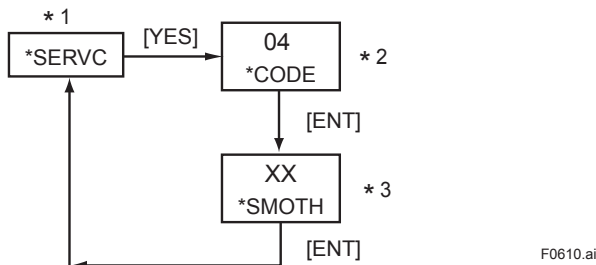

- *1: See "Figure 6.4 Process at the Setting Level" on page 6-12 .
- *2: Enter the code number.
- *3: Set a value using the [>] , [^] and [ENT] keys.
If you enter a value that exceeds the limits, the display shows [*OVER].
Press the [YES] or [NO] key to re-set the value.

Figure 6.10 Setting of Output-smoothing Constants

CODE 05: Setting of Contact Outputs Status [*CNTCT]

This setting defines the status of the contact outputs.

Configurable range: 00 to 15

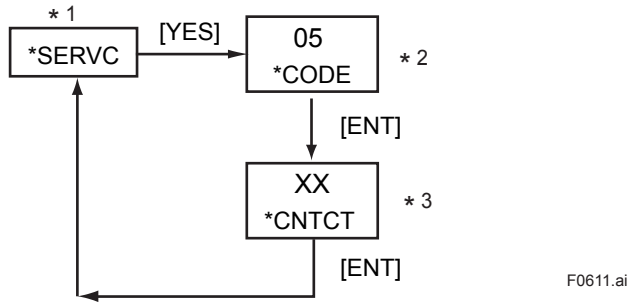

- *1: See "Figure 6.4 Process at the Setting Level" on page 6-12.
- *2: Enter the code number.
- *3: Set a value using the [>], [^] and [ENT] keys.
If you enter a value that exceeds the limits, the display shows [*OVER].
Press the [YES] or [NO] key to re-set the value.

Figure 6.11 Setting of Contact Outputs Status

Each contact output takes either of the following two status (in table); depending on the value you set.

Value	ZERO contact	SPAN contact	MAINT contact	ALM contact
0	NO	NO	NO	NO
1	NO	NO	NO	NC
2	NO	NO	NC	NO
3	NO	NO	NC	NC
4	NO	NC	NO	NO
5	NO	NC	NO	NC
6	NO	NC	NC	NO
7	NO	NC	NC	NC
8	NC	NO	NO	NO
9	NC	NO	NO	NC
10	NC	NO	NC	NO
11	NC	NO	NC	NC
12	NC	NC	NO	NO
13	NC	NC	NO	NC
14	NC	NC	NC	NO
15	NC	NC	NC	NC

NO: means "normally open"
NC: means "normally closed"

CODE 10: Setting of Pressure Compensation

This setting determines whether or not the measured density should be compensated by the gas pressure. The density can be compensated to either the value immediately before the error or a fixed value.

(a) Enable/disable/select preset value [*P.COMP]

- Disable: 0
- Enable (value immediately before): 1
- Enable (fixed value): 2

(b) Setting of fixed value for pressure compensation [*P.FIX]

This item applies if item (a) above is set to "2".

Configurable range: 0.10 to 999.99 (for kPa),
0.0001 to 9.9999 (for MPa),
0.015 to 99.999 (for psi)

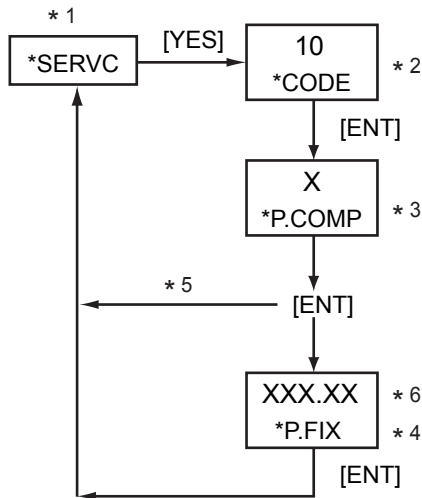

- *1: See "Figure 6.4 Process at the Setting Level" on page 6-12.
- *2: Enter the code number.
- *3: Set a value using the [^] and [ENT] keys.
- *4: Set a value using the [>], [^] and [ENT] keys.
If you enter a value that exceeds the limits, the display shows [*OVER].
Press the [YES] or [NO] key to re-set the value.
- *5: Setting 0 or 1 returns to the service level with the indication [*SERVC].
- *6: The position of the decimal point changes depending on the setting of CODE 20.
If the code is set to "0" (kPa), the reading is XXX.XX;
if the code is set to "1" (MPa), the reading is X.XXXX;
if the code is set to "2" (psi), the reading is XX.XXX.

Figure 6.12 Setting of Pressure Compensation

CODE 11: Setting for Compensated Density Measurement

This setting defines the reference temperature and pressure required to obtain the compensated density.

(a) Setting of reference temperature [*C.D.TMP]

Configurable range: -20.0 to 80.0 (for °C)
 -4.0 to 176.0 (for °F)

(b) Setting of reference pressure [*C.D.PRS]

Configurable range: 0.10 to 999.99 (for kPa),
 0.0001 to 9.9999 (for MPa),
 0.015 to 99.999 (for psi)

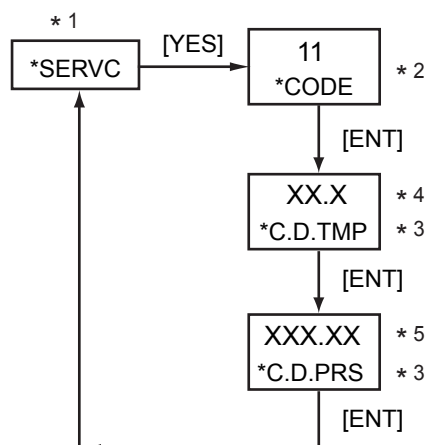

F0613.ai

*1: See "Figure 6.4 Process at the Setting Level" on page 6-12.

*2: Enter the code number.

*3: Set a value using the [>], [^] and [ENT] keys.

If you enter a value that exceeds the limits, the display shows [*OVER].

Press the [YES] or [NO] key to re-set the value.

*4: The position of the decimal point changes depending on the setting of CODE 23.

If the code is set to "0" (°C), the reading is XX.X;

if the code is set to "1" (°F), the reading is XXX.X.

*5: The position of the decimal point changes depending on the setting of CODE 20.

If the code is set to "0" (kPa), the reading is XXX.XX;

if the code is set to "1" (MPa), the reading is X.XXXX;

if the code is set to "2" (psi), the reading is XX.XXX.

Figure 6.13 Setting for Compensated Density Measurement

CODE 12: Setting of Gas Pressure

This setting defines the zero and span points of the pressure transmitter's measurement range.

(a) Setting of zero-point gas pressure [*Z_PRS]

Configurable range: 0.01 to 999.99 (for kPa),
0.0001 to 9.9999 (for MPa),
0.015 to 99.999 (for psi)

(b) Setting of span-point gas pressure [*S_PRS]

Configurable range: 0.10 to 999.99 (for kPa),
0.0001 to 9.9999 (for MPa),
0.015 to 99.999 (for psi)

The zero and span points set here are also used for the analog output.

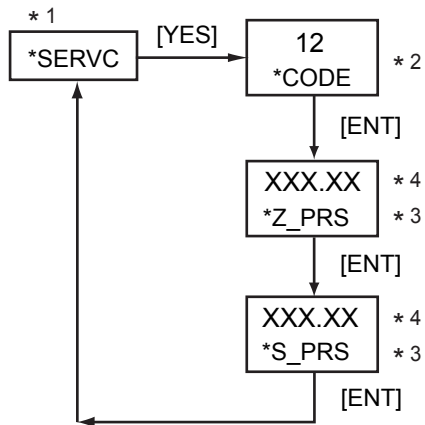

F0614.ai

- *1: See "Figure 6.4 Process at the Setting Level" on page 6-12.
- *2: Enter the code number.
- *3: Set a value using the [>], [^] and [ENT] keys.
If you enter a value that exceeds the limits, the display shows [*OVER].
Press the [YES] or [NO] key to re-set the value.
- *4: The position of the decimal point changes depending on the setting of CODE 20.
If the code is set to "0" (kPa), the reading is XXX.XX;
if the code is set to "1" (MPa), the reading is X.XXXX;
if the code is set to "2" (psi), the reading is XX.XXX.

Figure 6.14 Setting of Gas Pressure

CODE 13: Selection for Automatic Calibration [*AUTO.C]

This setting determines whether or not automatic calibration is carried out. If automatic calibration is to be carried out, you must also configure CODE 15 at the service level.

- Disable: 0
- Enable: 1

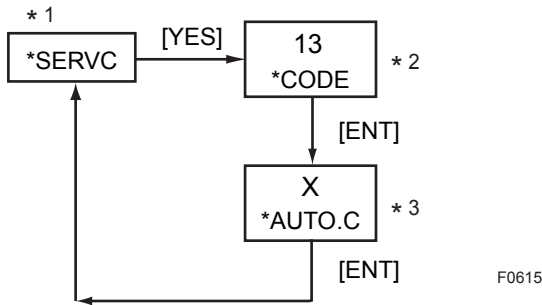

- *1: See "Figure 6.4 Process at the Setting Level" on page 6-12.
- *2: Enter the code number.
- *3: Set a value using the [>], [^] and [ENT] keys.

Figure 6.15 Selection for Automatic Calibration

CODE 14: Setting for Remote Semi-automatic Calibration [*REMOT]

This setting determines whether or not semi-automatic calibration is carried out remotely. If remote semi-automatic calibration is to be carried out, you must wire the contact input. You must also configure CODE 15 at the service level.

- Disable: 0
- Enable: 1

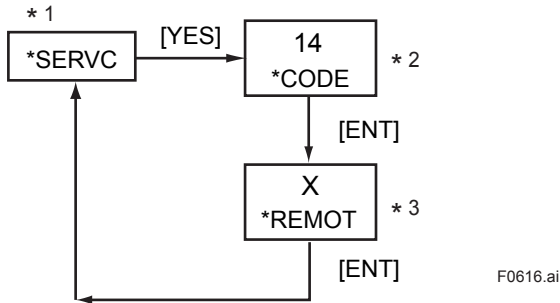

- *1: See "Figure 6.4 Process at the Setting Level" on page 6-12.
- *2: Enter the code number.
- *3: Set a value using the [>], [^] and [ENT] keys.

Figure 6.16 Setting for Remote Semi-automatic Calibration

CODE 15: Setting of Data for Automatic/Semi-automatic Calibration

This setting defines the data needed to carry out automatic/semi-automatic calibration.

- (a) Selection of calibration item [*CAL.P]
 - Zero and span: 0
 - Zero: 1
 - Span: 2
- (b) Setting of calibration time [*CAL.T]
 - Configurable range: 00 to 59 (unit : minute)
- (c) Setting of stabilization time [*STAB.T]
 - Configurable range: 00 to 59 (unit : minute)
- (d) Setting of calibration starting time
 - (1) Setting of year/month/day [*Y_M_D]
 - Configurable range: 00.01.01 to 99.12.31
 - (2) Setting of hour/minute [*H_M]
 - Configurable range: 00.00 to 23.59
- (e) Selection of unit of calibration interval [*CYCL.U]
 - Hour: 0
 - Day: 1
- (f) Selection of calibration interval [*CYCL.T]
 - Item (e) above is set to "0".
 - Configurable range: 00 to 23 (for hour)
 - Item (e) above is set to "1".
 - Configurable range: 000 to 255 (for day)

For more information, see Chapter 9, "Calibration Procedure".

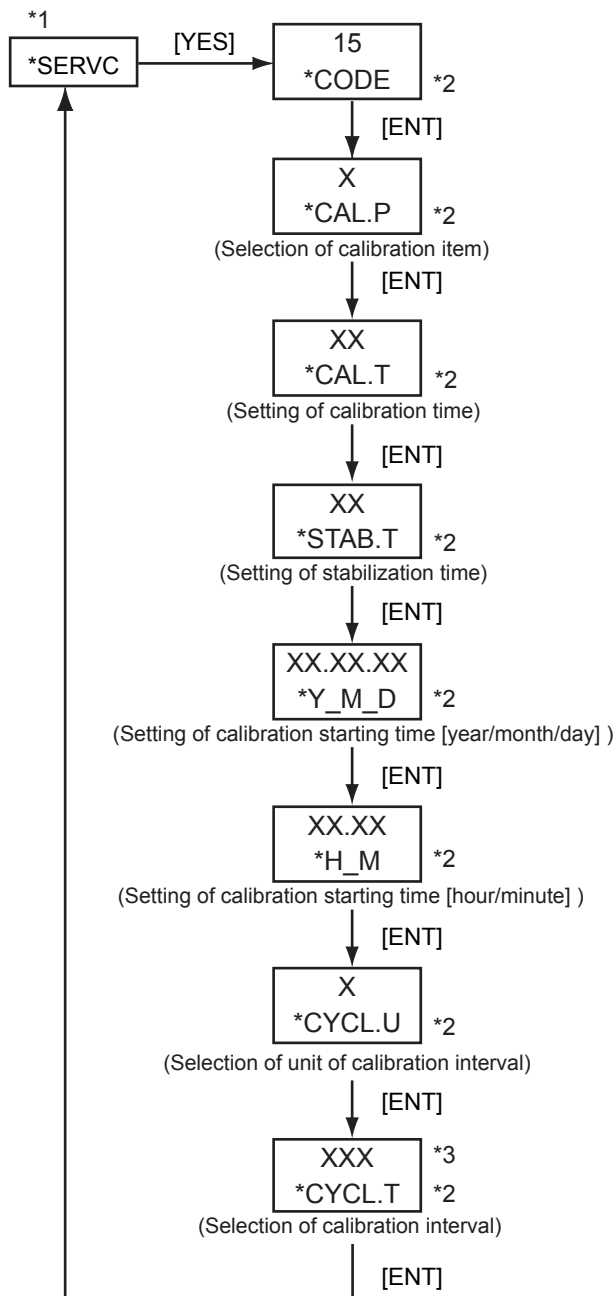

F0617.ai

*1: See "Figure 6.4 Process at the Setting Level" on page 6-12.

*2: Set a value using the [>], [^] and [ENT] keys.

If you enter a value that exceeds the limits, the display shows [*OVER].

Press the [YES] or [NO] key to re-set the value.

*3: The number of digits on LCD varies depending on the unit of the calibration interval (parameter *CYCL.U).

If the parameter is set to "0" (hour), the indication is two-digit number.

If the parameter is set to "1" (day), the indication is three-digit number.

Figure 6.17 Setting of Data for Automatic/Semi-automatic Calibration

CODE 20: Selection of Pressure Unit [*PRES.U]

This setting defines the pressure unit for the gas pressure transmitter.

- kPa: 0
- MPa: 1
- psi : 2

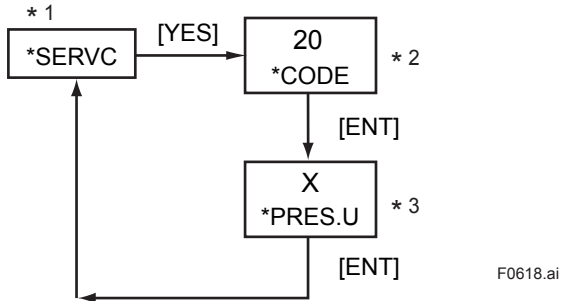

- *1: See "Figure 6.4 Process at the Setting Level" on page 6-12.
- *2: Enter the code number.
- *3: Set a value using the [>], [^] and [ENT] keys.

Figure 6.18 Selection of Pressure Unit

CODE 21: Selection of Density Unit [*DENS.U]

This setting defines the density unit for the gas density meter.

- kg/m³: 0
- lb/ft³: 1

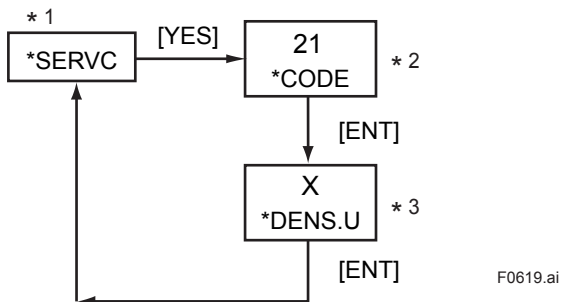

- *1: See "Figure 6.4 Process at the Setting Level" on page 6-12.
- *2: Enter the code number.
- *3: Set a value using the [>], [^] and [ENT] keys.

Figure 6.19 Selection of Density Unit

CODE 22: Selection of Calorific Value Unit [*CAL.U]

This setting defines the calorific value unit for the gas density meter.

- MJ/m³ : 0
- kBTU/ft³ : 1

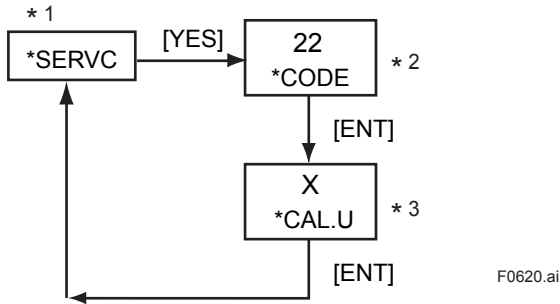

- *1: See "Figure 6.4 Process at the Setting Level" on page 6-12.
- *2: Enter the code number.
- *3: Set a value using the [>], [^] and [ENT] keys.

Figure 6.20 Selection of Calorific Value Unit

CODE 23: Selection of Temperature Unit [*TEMP.U]

This setting defines the temperature unit for the gas density meter.

- °C: 0
- °F: 1

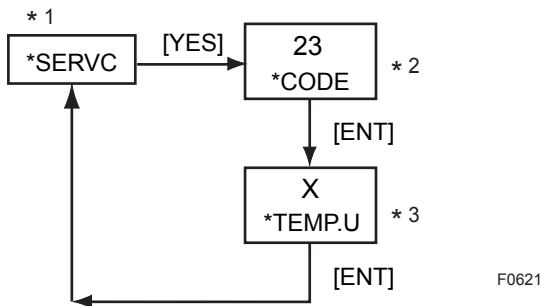

- *1: See "Figure 6.4 Process at the Setting Level" on page 6-12.
- *2: Enter the code number.
- *3: Set a value using the [>], [^] and [ENT] keys.

Figure 6.21 Selection of Temperature Unit

CODE 30: Setting of Calendar

This setting defines the date and time.

(a) Setting of year/month/day [*Y_M_D]

Configurable range : 00.01.01 to 99.12.31

(b) Setting of hour/minute [*H_M]

Configurable range : 00.00 to 23.59

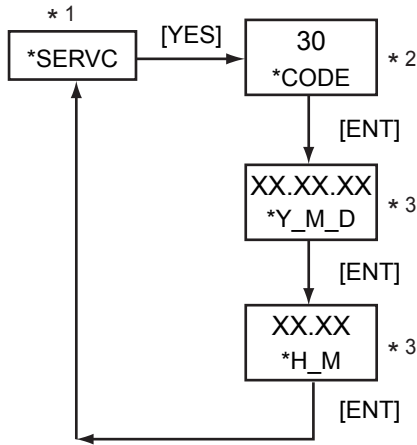

F0622.ai

*1: See "Figure 6.4 Process at the Setting Level" on page 6-12.

*2: Enter the code number.

*3: Set a value using the [>], [^] and [ENT] keys.

If you enter a value that exceeds the limits, the display shows [*OVER].

Press the [YES] or [NO] key to re-set the value.

Figure 6.22 Setting of Calendar

CODE 31: Showing/Hiding of Negative Measured Values [*MINUS]

This setting determines whether negative measured values (-) should be shown or hidden.

- Show: 0
- Hide: 1

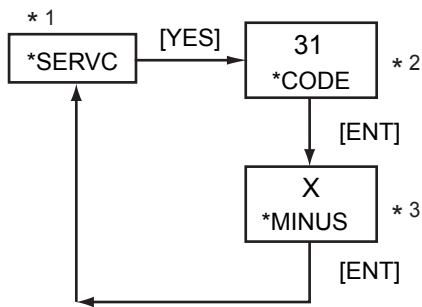

F0623.ai

*1: See "Figure 6.4 Process at the Setting Level" on page 6-12.

*2: Enter the code number.

*3: Set a value using the [>], [^] and [ENT] keys.

Figure 6.23 Showing/Hiding of Negative Measured Values

CODE 40: Indication of Calibration Coefficients (Read-only)

This setting determines the calibration coefficients to be indicated.

- (a) Zero [*C_K_Z]: indicated as SX.XXXX
- (b) Span [*C_K_S]: indicated as X.XXXX

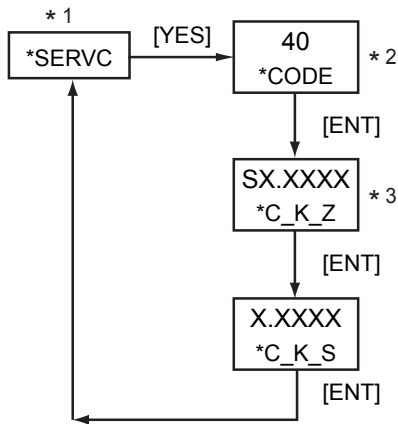

F0624.ai

- *1: See "Figure 6.4 Process at the Setting Level" on page 6-12.
- *2: Enter the code number.
- *3: By pressing the [ENT] key, the next indication is displayed.
This parameter does not accept the [>] and [^] key input.

Figure 6.24 Indication of Calibration Coefficients

CODE 41: Indication of Oscillation Frequency (Read-only)

This setting determines the F2 and F4 oscillation frequencies coefficients to be indicated.

- (a) Indication of frequency F2 (kHz) [*F2.KHZ]: indicated as X.XXXXXX
- (b) Indication of frequency F4 (kHz) [*F4.KHZ]: indicated as X.XXXXXX
- (c) Indication of frequency ratio (kHz) [*F2/F4]: indicated as X.XXXXXX

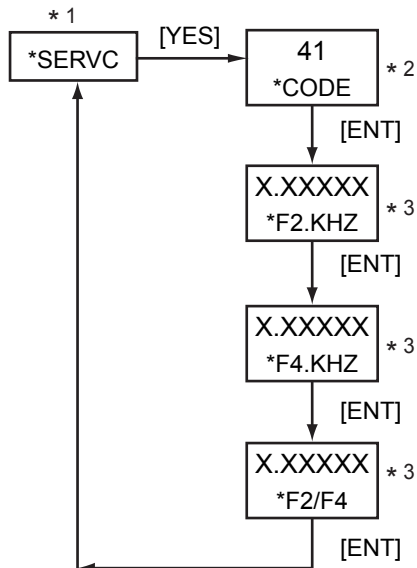

F0625.ai

- *1: See "Figure 6.4 Process at the Setting Level" on page 6-12.
- *2: Enter the code number.
- *3: By pressing the [ENT] key, the next indication is displayed.
This parameter does not accept the [>] and [^] key input.

Figure 6.25 Indication of Oscillation Frequency

CODE 42: Indication of Software Version [*REV] (Read-only)

This setting allows the software version to be confirmed (indicated).
Indicated as X.XX

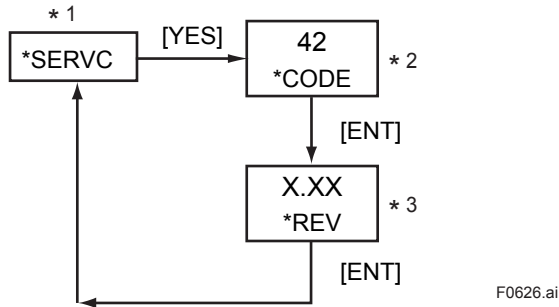

- *1: See "Figure 6.4 Process at the Setting Level" on page 6-12.
- *2: Enter the code number.
- *3: Pressing the [ENT] key returns to the service level with the indication [*SERVC].
This parameter does not accept the [>] and [^] key input.

Figure 6.26 Indication of Software Version

CODE 43: Setting of High-resolution Mode [*S_CYC]

This setting selects between the normal mode and the high-resolution mode.

- Normal mode: 0
- High-resolution mode: 1

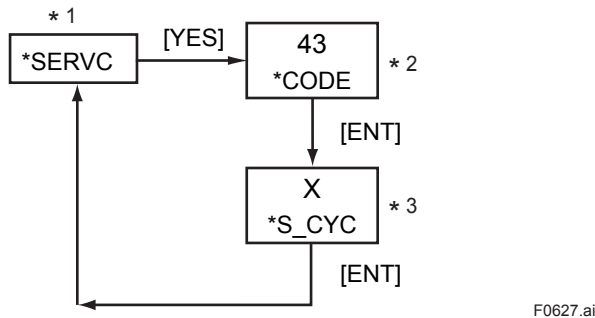

- *1: See "Figure 6.4 Process at the Setting Level" on page 6-12.
- *2: Enter the code number.
- *3: Set a value by using the [>], [^] and [ENT] keys.

Figure 6.27 Setting of High-resolution Mode

CODE 44: Setting of PASSWORD [*PASS]

This setting defines the password.

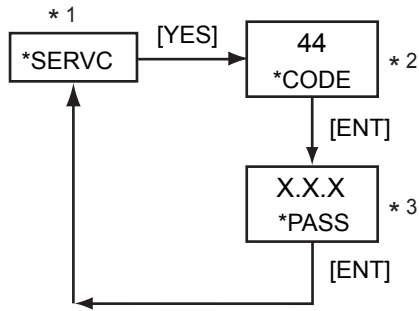

F0628.ai

*1: See "Figure 6.4 Process at the Setting Level" on page 6-12.

*2: Enter the code number.

*3: Set a value by using the [>], [^] and [ENT] keys.

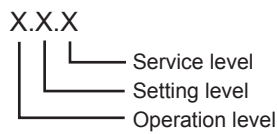

Note: Password entry request (if a password is set)

At the operation level, a request is issued when the [MODE] key is pressed in the measurement mode. At the setting level, it is issued when the [*] key is pressed. At the service level, it is issued when the [YES] key is pressed with [*SERVC] displayed.

Password	
X (Setting)	Contents
(0)	(No setting)
1	111
2	333
3	777
4	888
5	123
6	957
7	331
8	546
9	847

Figure 6.28 Setting of Password

CODE 45: Selecting Battery alarm detection [*BAT]

This setting determines whether or not battery alarm is detection.

- Non detection: 0
- Detection: 1

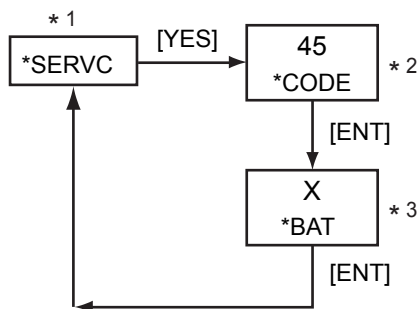

F 629.ai

*1: See "Figure 6.4 Process at the Setting Level" on page 6-12.

*2: Enter the code number.

*3: Set a value by using the [>], [^] and [ENT] keys.

Figure 6.29 Selecting Battery alarm detection

CODE 50: Selecting the instruments [*MODEL]

This setting defines the model.

- Density meter: 0
- Calorie meter: 1
- Hydrogen purity, replacement meter : 2

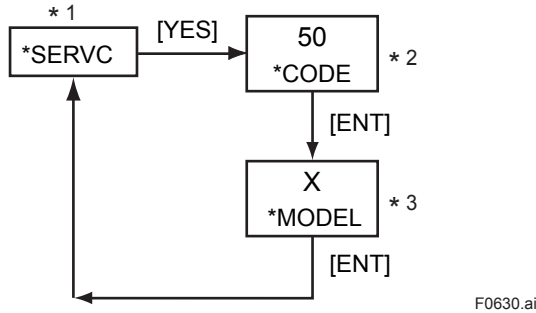

- *1: See "Figure 6.4 Process at the Setting Level" on page 6-12.
- *2: Enter the code number.
- *3: Set a value by using the [>], [^] and [ENT] keys.

Figure 6.30 Selecting the instruments

CODE 82: Setting Detector Constant

This setting defines the detector constant.



CAUTION

The instruments may not only work improperly but also big problems occur unless the detector constants entered incorrectly. Do carefully and precisely when enter the detector constants into converter.

1. The GD402 gas density meter is shipped after adjusting the detector and converter in pairs. When installation, confirm the converter serial number described on the label of detector so that combines converter and detector correctly. If mismatched in pairs, converter may be out of order. If combined correctly, no need to enter the detector constants again, as converter has been adjusted with the constants in factory.
2. When supply converter or detector individually, enter the detector constants, described on inside the lid of the GD40, into the converter so that the GD402 is going to be well.

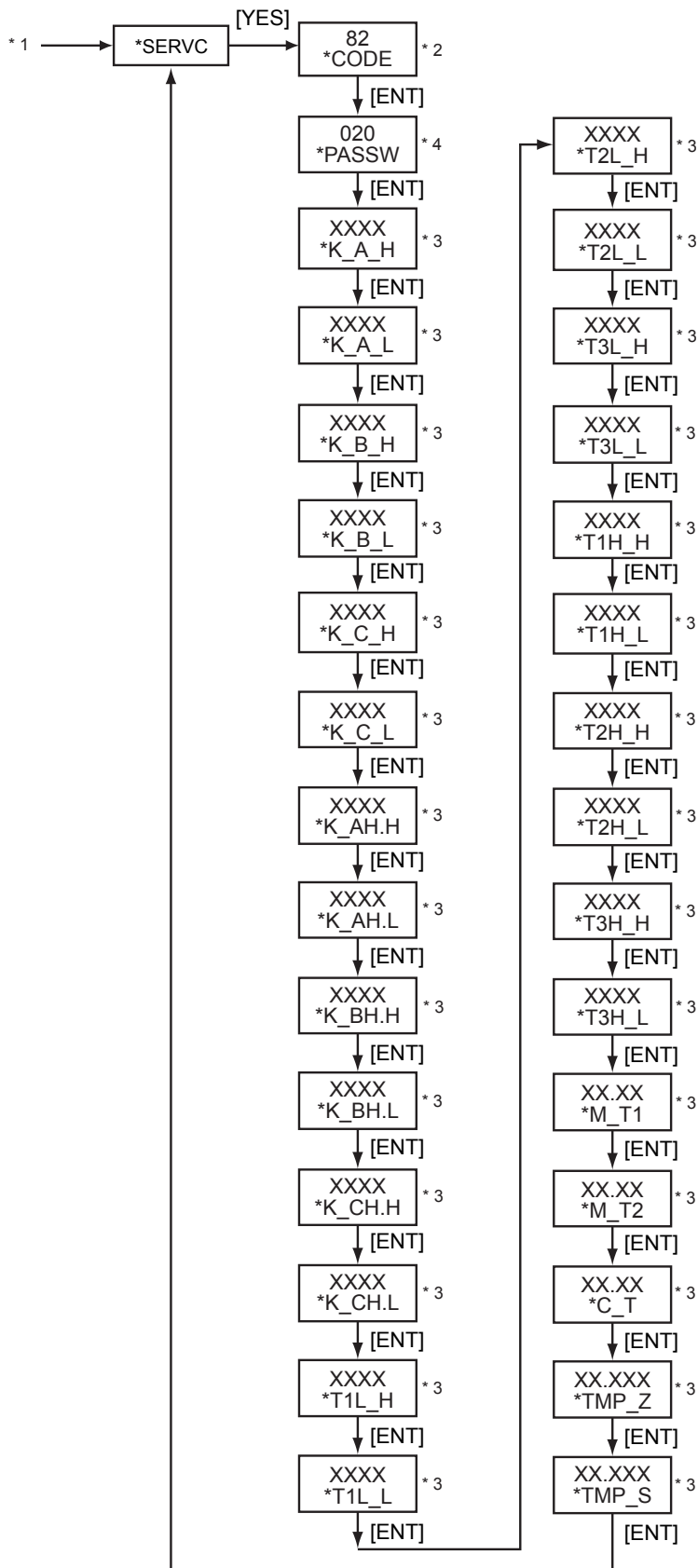

F0631.ai

- *1: See "Figure 6.4 Process at the Setting Level" on page 6-12.
- *2: Enter the code number.
- *3: Set a value using the [>], [^] and [ENT] keys.
Detector Constants are described inside the lid of detector GD40.
- *4: Set the PASSWORD.

Figure 6.31 Setting Detector Constant

7. HYDROGEN PURITY/PARAMETER SETTING

CAUTION

Password is not selected in first condition. When password is necessary, refer to Section "4.2 Setting Lists".

This chapter describes how to set parameters of Hydrogen purity meter.

If select Density meter, see Chapter 5.

If select Calorie meter, see Chapter 6.

Conversion Table

1 lb/ft ³	= 16.01847 kg/m ³
1 kBTU/ft ³	= 37.25901232 MJ/m ³
X degF	= (X-32)/1.8
1 psi	= 6.894756794 kPa
Density of Air	= 1.2928 kg/m ³
	= 0.08070684 lb/ft ³

7.1 Setting Parameters

Subsections 7.1.1 to 7.1.4 show the setting parameters for each level.

7.1.1 Setting Parameters at Measurement Level

When turned on, the analyzer starts up in the measurement mode (<MEASURE>).

Table 7.1 Setting Parameters at Measurement Level

Mode/Setting parameter	Display	Data to be Set (or Conditions)	Remarks
Measurement mode			See Figure 7.2 for key operation.
Indication of measurement value			
Physical density	KG/M3 LB/FT3	Set the unit in CODE 21.	
Compensated density	KG/M3 LB/FT3	Set the unit in CODE 21.	
Hydrogen purity	H2_AIR H2_CO2 A_CO2		The display shows the measuring range selected in the measuring range selection mode.
Indication of message			
Unit			The unit is the one set in the service level.
Error symbol and number	ERR.NO		Appears if an error occurs.
Alarm mark and number	ALM.NO		Appears if an alarm occurs.
Indication of HOLD and FAIL			Appears even during other modes.
HOLD	HOLD		Appears during a HOLD state.
FAIL	FAIL		Appears if a failure occurs.
Selection of measuring range	S_GAS	Select the item to be measured with hydrogen purity meter.	See Figure 7.1 for key operation.
Hydrogen purity	H2_AIR	H2 in AIR	
Substituents-concentration	H2_CO2	H2 in CO2	
Substituents-concentration	A_CO2	AIR in CO2.	

7.1.2 Setting Parameters at Operation Level

Press the [MODE] key and enter the password (XXX) to gain access to this level (see Figure 7.1 for key operation).

Table 7.2 Setting Parameters at Operation Level

Mode/Setting parameter	Display	Data to be Set (or Conditions)	Remarks
DISP mode	DISP		See Figure 7.2 for key operation.
Physical density	KG/M3 LB/FT3	Set the unit in CODE 21.	Selection of parameters to be measured in the measurement mode.
Compensated density	KG/M3 LB/FT3	Set the unit in CODE 21.	
Hydrogen purity	H2_AIR H2_CO2 A_CO2		
Sample gas temperature	°C °F	Set the unit in CODE 23.	Read-only
Sample gas pressure	KPA MPA PSI	Set the unit in CODE 20.	Read-only
Analog output 1 (%)	MA1%		Read-only
Analog output 2 (%)	MA2%		Read-only
Calibration mode			
Manual calibration	MAN.CAL		See Figure 10.2 for key operation.

7.1.3 Setting Parameters at Setting Level

Press the [*] key and enter the password (XXX) to gain access to this level (see Figure 7.4 for key operation).

Table 7.3 Setting Parameters at Setting Level

Mode/Setting parameter	Display	Data to be Set (or Conditions)	Remarks
Analog output setting mode Output 1 Set a parameter to be output Set the zero and span points Physical density Compensated density Hydrogen purity Substituents-concentration Output 2 (same as output 1)	*RANGE *OUT1 *DENS *C_DNS *H_A *H_C_A *TEMP *PRESS *Z_DNS, *S_DNS *Z_CP.D, *S_CP.D *Z_H_A, *S_H_A *Z_H.C.A, *S_H.C.A *OUT2	Physical density Compensated density Hydrogen purity Substituents-concentration Gas temperature Gas pressure 00.0000 to 60.0000 kg/m ³ 0.00000 to 4.00000 lb/ft ³ 0.0000 to 6.0000 kg/m ³ 0.00000 to 0.40000 lb/ft ³ 0.00000 to 0.40000 0.0 to 100.0	See Figure 7.5 for key operation. No setting is required if the parameter is temperature or pressure.
Setting of calibration data Output hold value during calibration Setting of preset value (Only if the preceding parameter is set to 2 (preset value))	*CAL.DT *C_HLD *PR.SET	· Disable: 0 · Enable (value immediately before) : 1 · Enable (preset value) : 2 -10.0 to 110.0	See Figure 10.1 for key operation.
Alarm-point setting mode Select a parameter for which an alarm is raised Physical density Compensated density Hydrogen purity Set the high/low limits Physical density Compensated density Hydrogen purity	*ALARM *DENS *C_DNS *H_A *L_DNS, *H_DNS *L_CP.D, *H_CP.D *L_H_A	0.0000 to 6.0000 kg/m ³ 0.00000 to 4.00000 lb/ft ³ 0.0000 to 6.0000 kg/m ³ 0.00000 to 0.40000 lb/ft ³ 0.0 to 100.0	See Figure 7.6 for key operation.

7.1.4 Setting Parameters at Service Level

Press the [*] key and enter the password (XXX) to select the service level. When you select this level, the analyzer shows a Code No. promptly. Type the appropriate code number and press the [ENT] key.

Table 7.4 Setting Parameters at Service Level

Code No.	Item	Display	Data to be Set (or Conditions)	Remarks
01	Setting of hold during maintenance Hold enable/disable	*M_HLD	· Disable : 0 · Enable (value immediately before) : 1	See Figure 7.8 for key operation.
	Setting of preset hold value	*PR.SET	· Enable (preset value) : 2 -10.0 to 110.0	If "preset value" is selected in the preceding parameter.
02	Setting of hold against errors Hold enable/disable	*E_HLD	· Disable : 0 · Enable (value immediately before) : 1	See Figure 7.9 for key operation.
	Setting of preset hold value	*PR.SET	· Enable (preset value) : 2 -10.0 to 110.0	If "preset value" is selected in the preceding parameter.
03	Setting of hydrogen purity range Hold enable/disable	*H_HLD	· Disable : 0 · Enable (value immediately before) : 1	See Figure 7.10 for key operation.
	Setting of the preset hold value	*PR.SET	· Enable (preset value) : 2 -10.0 to 110.0	If "preset value" is selected in the preceding parameter.
04	Setting of output-smoothing constants	*SMOTH	00 to 60	See Figure 7.11 for key operation.
05	Setting of contact outputs status	*CNTCT	00 to 15	See Figure 7.12 for key operation.
10	Setting of pressure compensation Enable/disable/fixed value	*P.COMP	· Disable: 0 · Enable (measured value) : 1	See Figure 7.13 for key operation.
	Setting of fixed value for pressure correction	*P.FIX	· Enable (fixed value) : 2 0.10 to 999.99 kPa, 0.0001 to 9.9999 MPa, 0.015 to 99.999 psi	If "fixed value" is selected in the preceding parameter.
11	Setting for measurement compensated density Setting of reference temperature	*C.D.TMP	-20.0 to 80.0°C, -4.0 to 176.0°F	See Figure 7.14 for key operation.
	Setting of reference pressure	*C.D.PRS	0.10 to 999.99 kPa, 0.0001 to 9.9999 MPa, 0.015 to 99.999 psi	
12	Setting of gas pressure Setting of zero-gas pressure	*Z_PRS	0.01 to 999.99 kPa, 0.0001 to 9.9999 MPa, 0.015 to 99.999 psi	See Figure 7.15 for key operation.
	Setting of span-gas pressure	*S_PRS	0.10 to 999.99 kPa, 0.0001 to 9.9999 MPa, 0.015 to 99.999 psi	
14	Setting for remote semi-automatic calibration	*REMOT	· Disable : 0 · Enable : 1 Open contact : AIR in CO ₂ Closed contact : H ₂ in CO ₂	See Figure 7.16 for key operation.
20	Selection of pressure unit	*PRES.U	· kPa : 0 · MPa : 1 · psi : 2	See Figure 7.17 for key operation.
21	Selection of density unit	*DENS.U	· kg/m ³ : 0 · lb/ft ³ : 1	See Figure 7.18 for key operation.
23	Selection of temperature unit	*TEMP.U	· °C : 0 · °F : 1	See Figure 7.19 for key operation.
31	Showing/hiding of negative measured values (-)	*MINUS	· Show : 0 · Hide : 1	See Figure 7.20 for key operation.

Table 7.4 Setting Parameters at Service Level

Code No.	Item	Display	Data to be Set (or Conditions)	Remarks
40	Indication of calibration coefficients (read-only) Zero Span	*C_K_Z *C_K_S	SX.XXXX X.XXXX	See Figure 7.21 for key operation.
41	Indication of oscillation frequency (read-only) Frequency F2 Frequency F4 Frequency ratio	*F2.KHZ *F4.KHZ *F2/F4	X.XXXXX X.XXXXX X.XXXXX	See Figure 7.22 for key operation.
42	Indication of software version (read-only)	*REV	X.XX	See Figure 7.23 for key operation.
43	Setting of high-resolution mode	*S_CYC	· Normal resolution : 0 · High-resolution : 1	See Figure 7.24 for key operation.
44	Setting of password	*PASS	0.0.0 to 9.9.9	See Figure 7.25 for key operation.
45	Selecting Battery alarm detection	*BAT	· Non detection : 0 · Detection : 1	See Figure 7.26 for key operation.
50	Selecting the instruments	*MODEL	· Density meter : 0 · Calorie meter : 1 · Hydrogen purity, replacement meter : 2	See Figure 7.27 for key operation.
82	Setting Detector Constant			See Figure 7.28 for key operation.

7.2 Parameter Setting

[Aborting the Setting Operation]

Press the [MODE] key. Normally, the [MODE] key is used to move from the measurement (<MEASURE>) mode to a mode at the operation level. It also used to return to the measurement mode from other modes.

7.2.1 Parameter Setting at Measurement Level

1. Measuring Range Selection Mode

Operate the keys as shown below to switch between the hydrogen purity meter and replacement (substituents-concentration) meter.

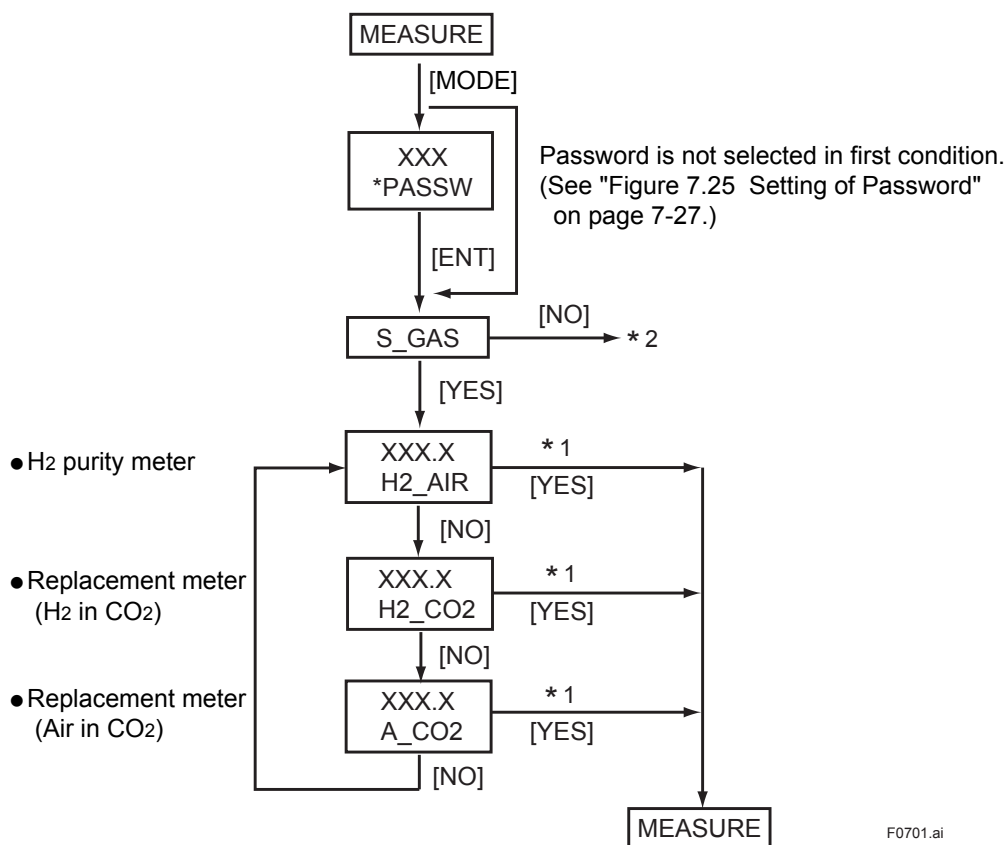

* 1 : Press the [YES] key to show the parameter in the measurement mode.
* 2 : See "Figure 7.3 Modes of Operation Level" on page 7-9.

Figure 7.1 Measuring Range Selection Mode

7.2.2 Parameter Setting at Operation Level

To move to the operation level, press the [MODE] key and then enter the password (XXX). Password is not selected in first condition. When password is necessary, refer to Section 4.2 "Setting Lists" and selected password what you need.

This level includes the manual calibration mode, which is discussed in Chapter 10.

(1) Operation Level

Select a mode from the following four choices of the operation level. Each press of the [NO] key cycles through the choices in the order shown below:

1. Measuring range selection mode [S_GAS]
2. Display mode [DISP]
3. Manual calibration mode [MAN.CAL]

Press the [YES] key to enter the desired mode when it is indicated.

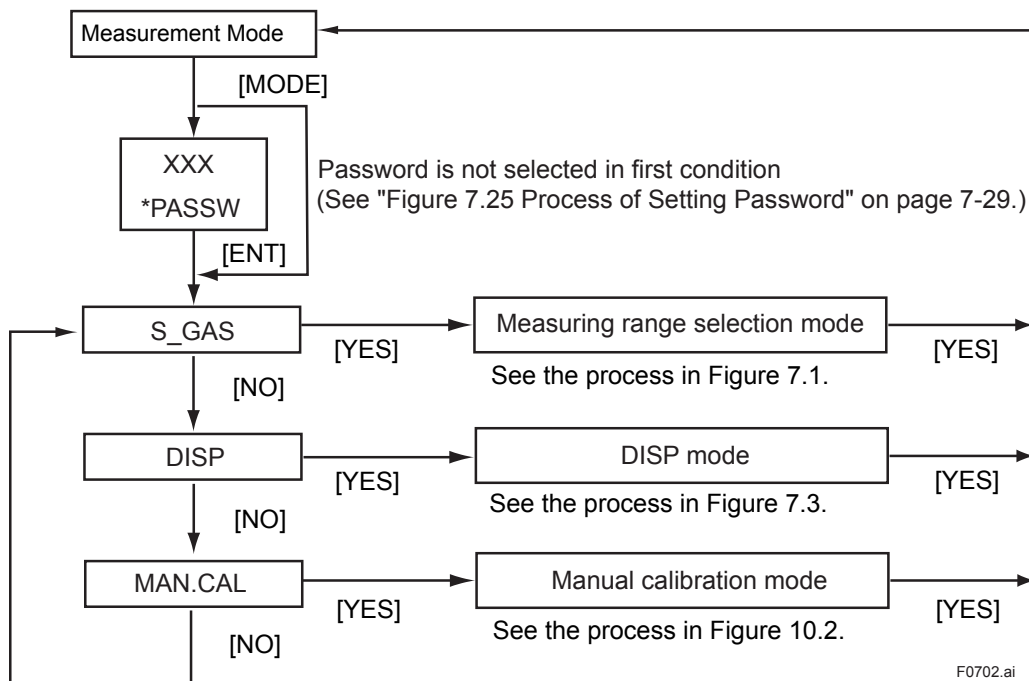

You can abort the setting operation in any of the modes by pressing [MODE] key. Doing this will return the analyzer to the measurement mode.

Figure 7.2 Modes of Operation Level

2. Display Mode

Select one of the following seven parameters to be shown in the message field. Each press of the [NO] key cycles through the choices in the order shown below:

1. Physical density [XX.XXXX KG/M3] or [XX.XXXXX LB/FT3]
(depends on the setting of CODE 21)
2. Compensated density [X.XXXX KG/M3] or [X.XXXXX LB/FT3]
(depends on the setting of CODE 21)
3. Concentration [XXX.X VOL%]
4. Temperature [XXX.X °C] or [XXX.X °F]
(depends on the setting of CODE 23)
5. Pressure [XXX.XX KPA] or [X.XXXX MPA] or [XX.XXX PSI]
(depends on the setting of CODE 20)
6. Current for analog output 1 (%) [XXX.X MA1%]
7. Current for analog output 2(%) [XXX.X MA2%]

Show the desired choice and press the [YES] key. That choice is set as a parameter to be measured in the measurement mode (<MEASURE>). Parameters 1, 2 and 3 are configurable, while parameters 4 to 7 are read-only.

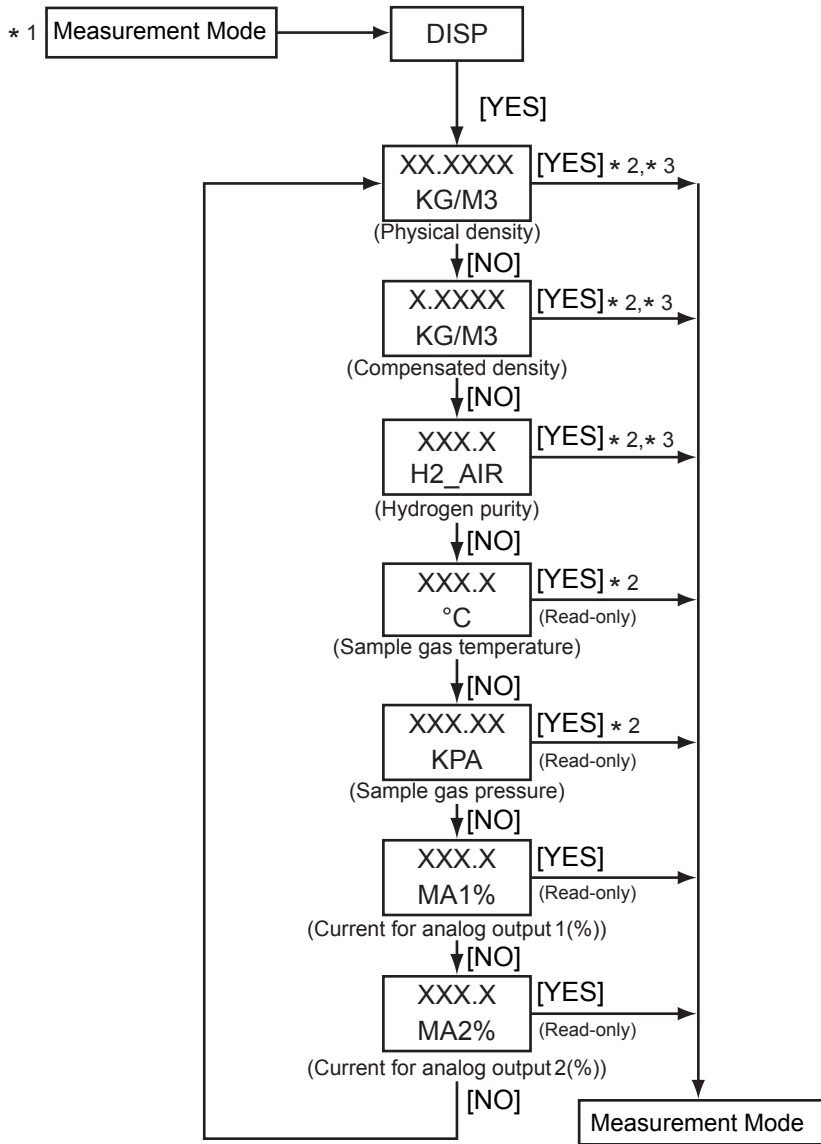

F0703.ai

*1: See "Figure 7.2 Modes of Operation Level" on page 7-7.

*2: The unit is the one set the service level.

*3: Press the [YES] key to show the parameter in the measurement mode.

Figure 7.3 Display Mode (DISP Mode)

7.2.3 Parameter Setting at Setting Level

To move to the setting level, press the [*] key and then enter the password (XXX). The main task at the setting level is to set data values such as the measuring range values.

Note that the function for which you have set data values at the setting level, will not work if that function is turned off at another level. For this reason, care must be taken when dealing with modes that relate to each other. The setting level has four levels/modes, as shown below, although this subsection explains only the analog output setting and alarm-point setting modes. The calibration parameter setting mode is discussed in Chapter 10.

1. Analog output setting mode [*RANGE]
2. Calibration parameter setting mode [*CAL.DT]
3. Alarm-point setting mode [*ALARM]
4. Service level [*SERVC]

Select a mode from the above four choices. Each press of the [NO] key cycles through the choices in sequence. Press the [YES] key to enter the desired mode when it is indicated.

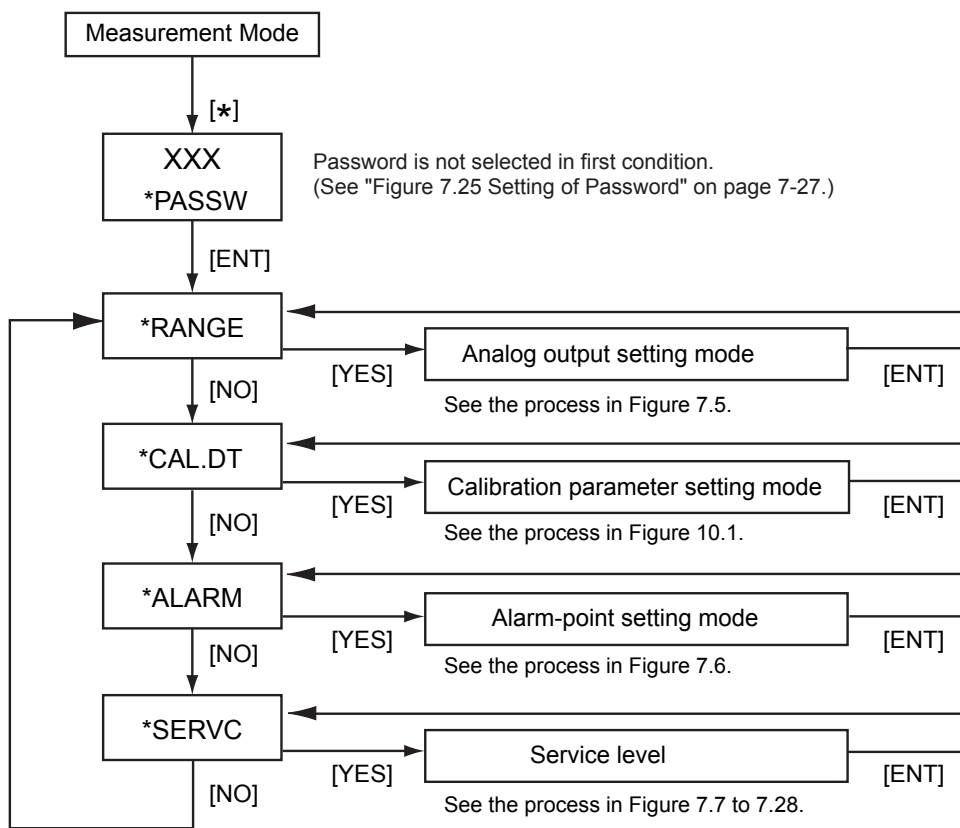

You can abort the setting operation in any of the modes by pressing the [MODE] key. Doing this will return the analyzer to the measurement mode.

F0704.ai

Figure 7.4 Process at the Setting Level

1. Analog Output Setting Mode [*RANGE]

The analog output has output 1 and output 2. Only output 1 can be used for communication purposes.

Set a range appropriate for 4-20 mA DC output signals. The range has two set-points: the lower limit (zero point) of the range corresponding to the minimum (0%) of a given output signal and the upper limit (span point) of the range corresponding to the maximum (100%) of the given output signal.

(1) Output 1 [*OUT1]

(a) Select a parameter to be output.

- Physical density [*DENS]
- Compensated density [*C_DNS]
- Hydrogen purity [*H_A] *1
- Substituents-concentration [*H_C_A] *2
- Gas temperature [*TEMP]
- Gas pressure [*PRESS]

*1: Not selectable (i.e., not shown) if the analyzer is in the replacement (substituents-concentration) meter mode.

*2: Not selectable (i.e., not shown) if the analyzer is in the hydrogen purity meter mode.

(b) Set the zero and span points. (This item is not applied if temperature or pressure are chosen as the parameter in item (a) above.)

- Physical density [*Z_DNS], [*S_DNS]
Configure range: 00.0000 to 60.0000 (kg/m³),
 0.00000 to 4.00000 (lb/ft³)
- Compensated density [*Z_CP.D], [*S_CP.D]
Configure range: 0.0000 to 6.0000 (kg/m³),
 0.00000 to 0.40000 (lb/ft³)
- Hydrogen purity [*Z_H_A] , [*S_H_A]
Configure range: 0.0 to 100.0
- Substituents-concentration [*Z_H.C.A] , [*S_H.C.A]
Configure range: 0.0 to 100.0

(2) Output 2 [*OUT2]

The same parameters as those of item (1) apply.

Note: If the same parameter is selected for both outputs 1 and 2, the zero/span point settings you made the last time apply when the parameter is output.

Example: Assume you first select parameter [*H_A] for analog output [*OUT1] and set the zero/span points as 100.0/0.0, and then select parameter [*H_A] for analog output [*OUT2] and set the zero/span points as 0.0/100.0. In that case, the parameter is output with the 0.0/100.0 zero/span point settings for both outputs 1 and 2.

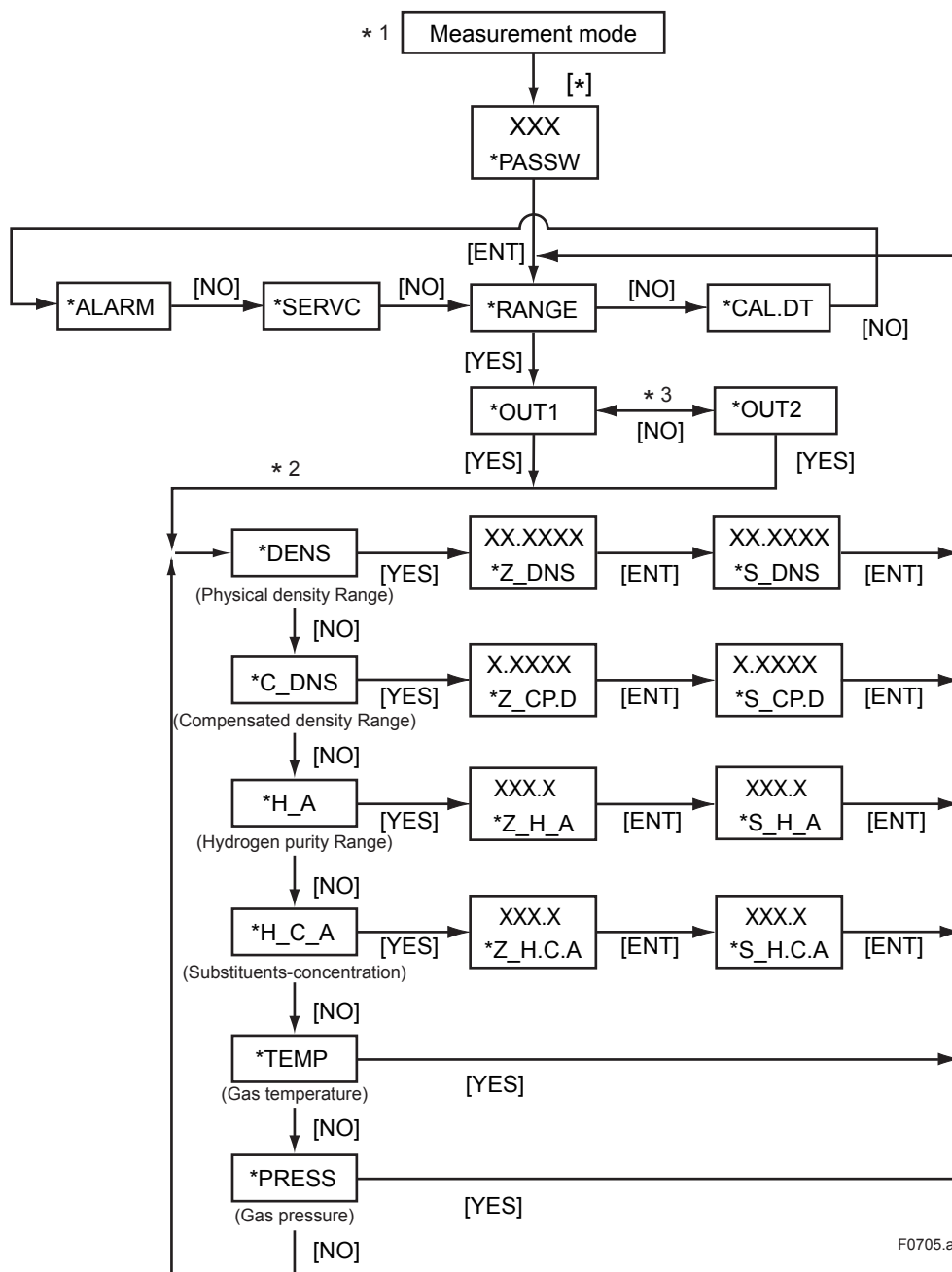

*1: You can abort the setting operation in any of the modes by pressing [MODE] key. Doing this will return the analyzer to the measurement mode.

*2: The display shows the previous parameter first.

*3: Each press of the [NO] key toggles between the parameters [*OUT1] and [*OUT2].

Figure 7.5 Process of the Analog Output Setting Mode

2. Alarm-point Setting Mode [*ALARM]

Set the upper /lower limits for the measured values of the parameters noted below, for the purpose of raising an alarm.

(a) Select a parameter for which alarms are raised.

- Physical density [*DENS]
- Compensated density [*C_DNS]
- Hydrogen purity [*H_A]

Press the [YES] key to enter the desired mode when it is indicated.

(b) Set the high/low limits.

- Physical density [*L_DNS], [*H_DNS]
 Configure range: 00.0000 to 60.0000 (kg/m³),
 0.00000 to 4.00000 (lb/ft³)
- Compensated density [*L_CP.D], [*H_CP.D]
 Configure range: 0.0000 to 6.0000 (kg/m³),
 0.00000 to 0.40000 (lb/ft³)
- Hydrogen purity [*L_H_A]
 Configure range: 0.0 to 100.0

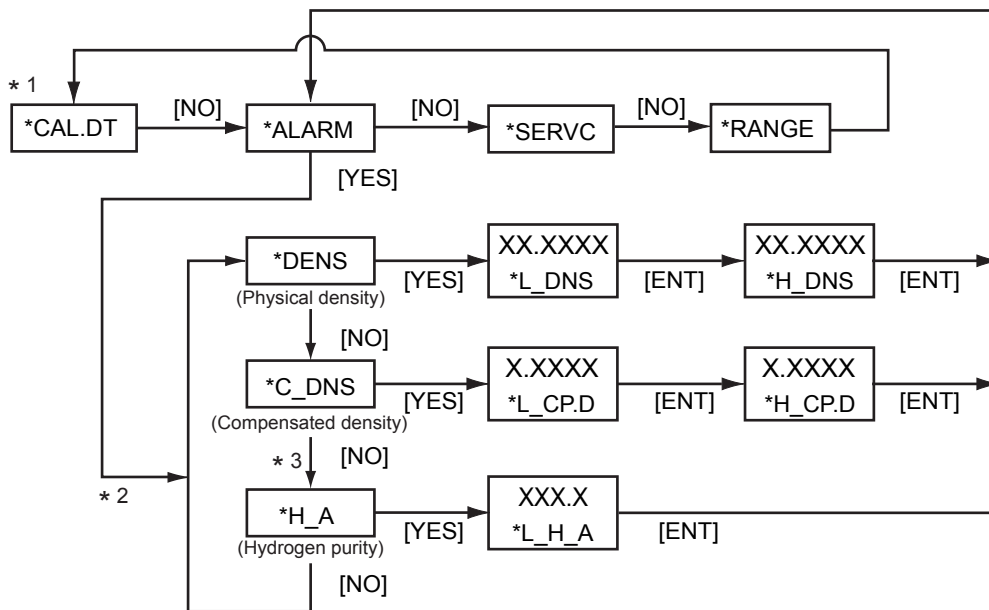

*1: See "Figure 7.4 Process at the Setting Level" on page 7-10.
 *2: The display shows the previous parameter first.
 *3: This step is skipped when the replacement meter is selected.

F0706.ai

Figure 7.6 Process of the Alarm-point Setting Mode

7.2.4 Parameter Setting at Service Level

To move to the service level, select [*SERVC] at the setting level, and press the [YES] key. (see Figure 7.4 on page 7-10.) The main task at the setting level is to set data values such as a measuring range. To go into each mode of the service level, enter the appropriate code number.

 **CAUTION**

DO NOT enter codes other than those listed in Table 7.4. A change to the settings of any unlisted code can result in the failure of the analyzer to operate properly. If you have entered a wrong code number by mistake, press the [MODE] key to return to the measurement mode(<MEASURE>). You may exit the mode of that wrong code by pressing the [ENT] key, if you haven't made any change to the relevant data.

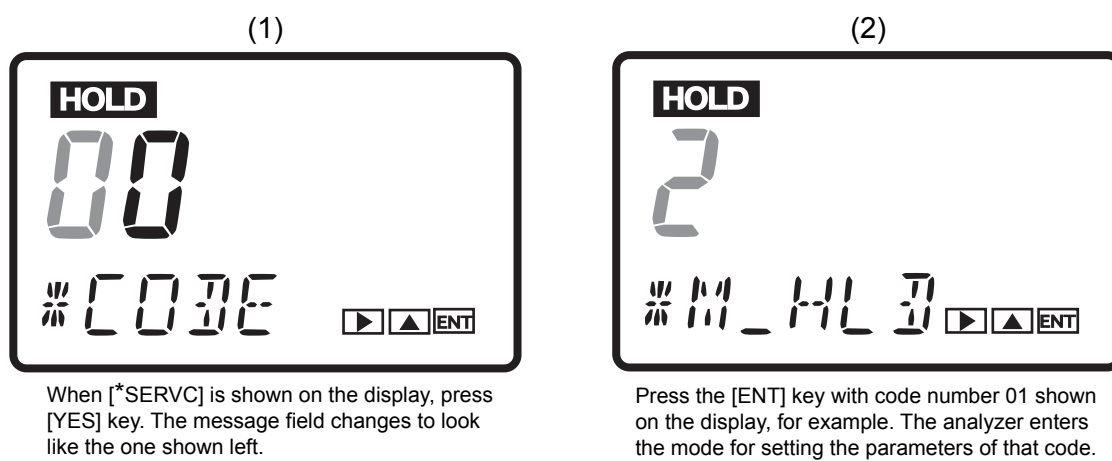

Figure 7.7 Entry of Code Number at Service Level

The following explains the parameter setting procedures in the order of code numbers.

CODE 01: Setting of Hold during Maintenance

This setting determines whether or not the output signal is held during maintenance. As a value to be held, you can select either a value immediately before or a preset value.

(a) Hold enable/disable [*M_HLD]

- Disable: 0
- Enable: 1
- Enable (preset value): 2

(b) Setting of preset hold value [*PR.SET]

This item applies if item (a) above is set to "2".

Configurable range: -10.0 to 110.0 (percent of analog output)

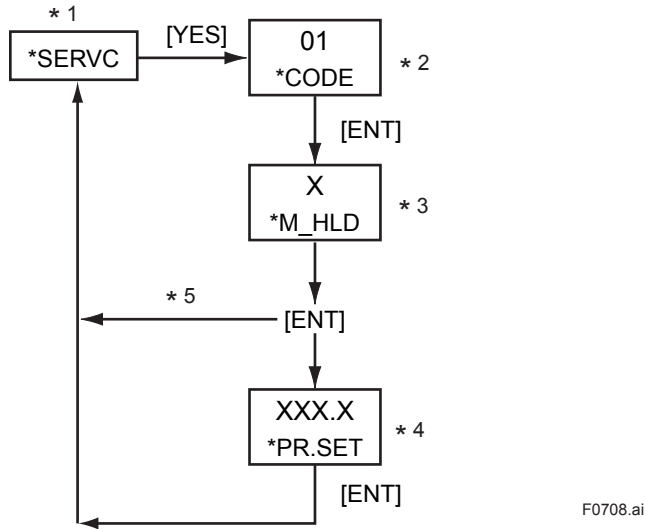

- *1: See "Figure 7.4 Process at the Setting Level" on page 7-10.
- *2: Enter the code number.
- *3: Set a value using the [^] and [ENT] keys.
- *4: Set a value using the [>], [^] and [ENT] keys.
If you enter a value that exceeds the limits, the display shows [*OVER].
Press the [YES] or [NO] key to re-set the value.
- *5: Setting 0 or 1 returns to the service level with the indication [*SERVC].

Figure 7.8 Setting of Hold for During Maintenance

CODE 02: Setting of Hold in the Event of Errors

This setting determines whether or not the output signal is held if an error occurs. You can select either the value immediately prior to the error or a preset value as the value to be held.

(a) Hold enable/disable [*E_HLD]

- Disable: 0
- Enable: 1
- Enable (preset value): 2

(b) Setting of preset hold value [*PR.SET]

This item applies if item (a) above is set to "2".

Configurable range: -10.0 to 110.0 (percent of analog output)

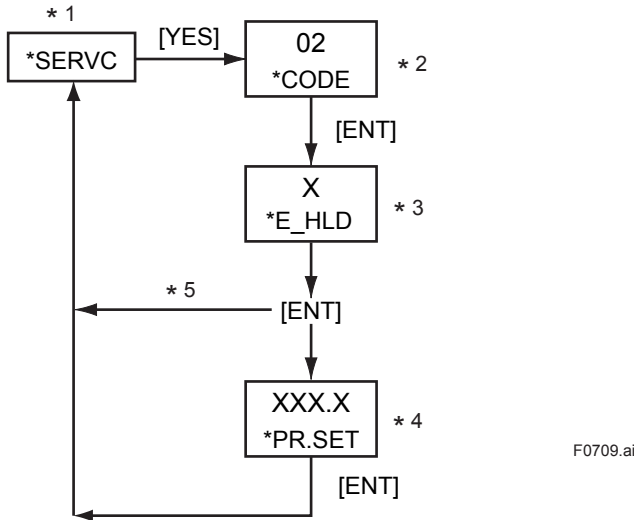

- *1: See "Figure 7.4 Process at the Setting Level" on page 7-10.
- *2: Enter the code number.
- *3: Set a value using the [\wedge] and [ENT] keys.
- *4: Set a value using the [>], [\wedge] and [ENT] keys.
If you enter a value that exceeds the limits, the display shows [*OVER].
Press the [YES] or [NO] key to re-set the value.
- *5: Setting 0 or 1 returns to the service level with the indication [*SERVC].

Figure 7.9 Setting of Hold in the Event of Error

CODE 03: Setting of Hold of Hydrogen Purity Range

This setting enables or disables the function for holding the output in the hydrogen purity range (hydrogen purity/replacement (substituents-concentration) meters mode only). You can select either the value immediately prior to the hold or a preset value as the value to be held.

(a) Hold enable/disable [*H_HLD]

- Disable: 0
- Enable: 1
- Enable (preset value): 2

(b) Setting of preset hold value [*PR.SET]

This item applies if item (a) above is set to "2".

Configurable range: -10.0 to 110.0 (percent of analog output)

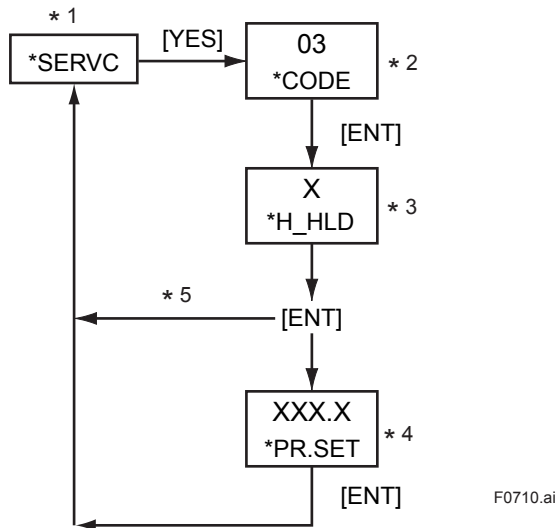

- *1: See "Figure 7.4 Process at the Setting Level" on page 7-10.
- *2: Enter the code number.
- *3: Set a value using the [^] and [ENT] keys.
- *4: Set a value using the [>], [^] and [ENT] keys.
If you enter a value that exceeds the limits, the display shows [*OVER].
Press the [YES] or [NO] key to re-set the value.
- *5: Setting 0 or 1 returns to the service level with the indication [*SERVC].

Figure 7.10 Process of Setting the Hold of Hydrogen Purity Range

[Note]

Relationship of CODE 01 to 03 with Output Hold Function Applied to Parameter [*CAL.DT] at Setting level.

Hydrogen purity/Replacement (Substituents-concentration) Meters Mode

Priority	Status	Hydrogen purity Range is Selected for Output	Hydrogen purity Range is Not Selected for Output
1	Error	The output value selected in CODE03	The output value selected in CODE 02
2	Calibration	The output value selected in CODE03	The output value selected for data item [*C_HLD] under parameter [*CAL.DT]
3	Maintenance	The output value selected in CODE03	The output valve selected in CODE 01
4	Switch to replacement meter mode	The output value selected in CODE03	The normal output condition applies

Example: If you select parameter [*H_A] for output 1 and parameter [*H_C_A] for output 2, then the resulting status-by-status output values to be held are summarized as follows:

	Output 1	Output 2
During error status	As per CODE 03	As per CODE02
During calibration status	As per CODE 03	As per data item [*C_HLD] under parameter [*CAL.DT]

CODE 04: Setting of Output-smoothing Constants [*SMOTH]

This setting defines the constants for output smoothing.

This smoothing constants is output-smoothing constants of converter (electrical circuit boards).

Configurable range: 00 to 60. (unit : second)

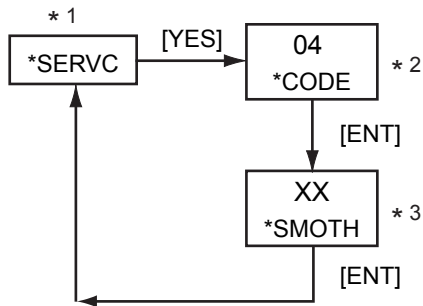

F0711.ai

*1: See "Figure 7.4 Process at the Setting Level" on page 7-10.

*2: Enter the code number.

*3: Set a value using the [>], [^] and [ENT] keys.

If you enter a value that exceeds the limits, the display shows [*OVER].
Press the [YES] or [NO] key to re-set the value.

Figure 7.11 Setting of Output-smoothing Constants

CODE 05: Setting of Contact Outputs Status [*CNTCT]

This setting defines the status of the contact outputs.

Configurable range: 00 to 15

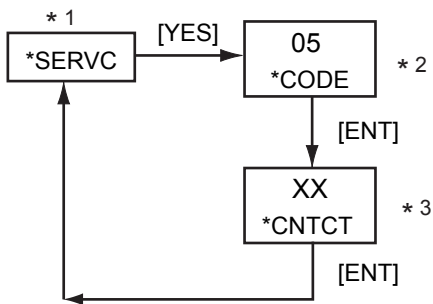

F0712.ai

*1: See "Figure 7.4 Process at the Setting Level" on page 7-10.

*2: Enter the code number.

*3: Set a value using the [>], [^] and [ENT] keys.

If you enter a value that exceeds the limits, the display shows [*OVER].
Press the [YES] or [NO] key to re-set the value.

Figure 7.12 Setting of Contact Outputs Status

Each contact output takes either of the following two status (in table); depending on the value you set.

Value	SEL GAS contact	FUNC contact	MAINT contact	ALM contact
0	NO	NO	NO	NO
1	NO	NO	NO	NC
2	NO	NO	NC	NO
3	NO	NO	NC	NC
4	NO	NC	NO	NO
5	NO	NC	NO	NC
6	NO	NC	NC	NO
7	NO	NC	NC	NC
8	NC	NO	NO	NO
9	NC	NO	NO	NC
10	NC	NO	NC	NO
11	NC	NO	NC	NC
12	NC	NC	NO	NO
13	NC	NC	NO	NC
14	NC	NC	NC	NO
15	NC	NC	NC	NC

NO: means "normally open"
NC: means "normally closed"

CODE 10: Setting of Pressure Compensation

This setting determines whether or not the measured density should be compensated by the gas pressure. The density can be compensated either by receiving a signal from a pressure transmitter or by using a fixed pressure set-point.

If you want the analyzer to compensate the density using a pressure transmitter, you **MUST** connect a pressure transmitter to the converter and enter the pressure input and zero and span points with CODE 12 at the service level.

If you do not want the analyzer to compensate the density, the analyzer shows and outputs the measured density equivalent to a value at an atmospheric pressure of unity (101.33 kPa ABS)..

(a) Enable/disable/select preset value [*P.COMP]

- Disable: 0
- Enable (value immediately before): 1
- Enable (fixed value): 2

(b) Setting of fixed value for pressure compensation [*P.FIX]

This item applies if item (a) above is set to "2".

Configurable range: 0.10 to 999.99 (for kPa),
0.0001 to 9.9999 (for MPa),
0.015 to 99.999 (for psi)

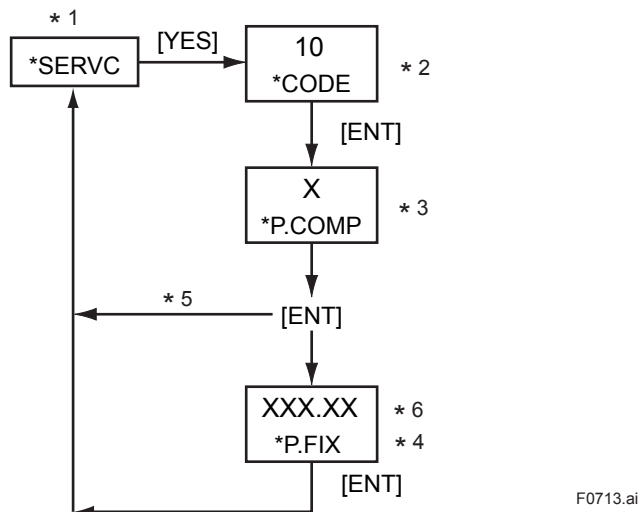

F0713.ai

- *1: See "Figure 7.4 Process at the Setting Level" on page 7-10.
- *2: Enter the code number.
- *3: Set a value using the [^] and [ENT] keys.
- *4: Set a value using the [>], [^] and [ENT] keys.
If you enter a value that exceeds the limits, the display shows [*OVER].
Press the [YES] or [NO] key to re-set the value.
- *5: Setting 0 or 1 returns to the service level with the indication [*SERVC].
- *6: The position of the decimal point changes depending on the setting of CODE 20.
If the code is set to "0" (kPa), the reading is XXX.XX;
if the code is set to "1" (MPa), the reading is X.XXXX;
if the code is set to "2" (psi), the reading is XX.XXX.

Figure 7.13 Setting of Pressure Compensation

CODE 11: Setting for Compensated Density Measurement

This setting defines the reference temperature and pressure required to obtain the compensated density.

(a) Setting of reference temperature [*C.D.TMP]

Configurable range: -20.0 to 80.0 (for °C)
-4.0 to 176.0 (for °F)

(b) Setting of reference pressure [*C.D.PRS]

Configurable range: 0.10 to 999.99 (for kPa),
0.0001 to 9.9999 (for MPa),
0.015 to 99.999 (for psi)

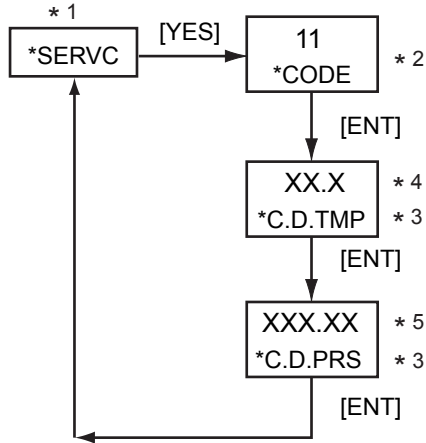

F0714.ai

- *1: See "Figure 7.4 Process at the Setting Level" on page 7-10.
- *2: Enter the code number.
- *3: Set a value using the [>], [^] and [ENT] keys.
If you enter a value that exceeds the limits, the display shows [*OVER.]
Press the [YES] or [NO] key to re-set the value.
- *4: The position of the decimal point changes depending on the setting of CODE 23.
If the code is set to "0" (°C), the reading is XX.X;
if the code is set to "1" (°F), the reading is XXX.X.
- *5: The position of the decimal point changes depending on the setting of CODE 20.
If the code is set to "0" (kPa), the reading is XXX.XX;
if the code is set to "1" (MPa), the reading is X.XXXX;
if the code is set to "2" (psi), the reading is XX.XXX.

Figure 7.14 Setting for Compensated Density Measurement

CODE 12: Setting of Gas Pressure

This setting defines the zero and span points of the pressure transmitter's measurement range.

(a) Setting of zero-point gas pressure [*Z_PRS]

Configurable range: 0.01 to 999.99 (for kPa),
0.0001 to 9.9999 (for MPa),
0.015 to 99.999 (for psi)

(b) Setting of span-point gas pressure [*S_PRS]

Configurable range: 0.10 to 999.99 (for kPa),
0.0001 to 9.9999 (for MPa),
0.015 to 99.999 (for psi)

The zero and span points set here are also used for the analog output.

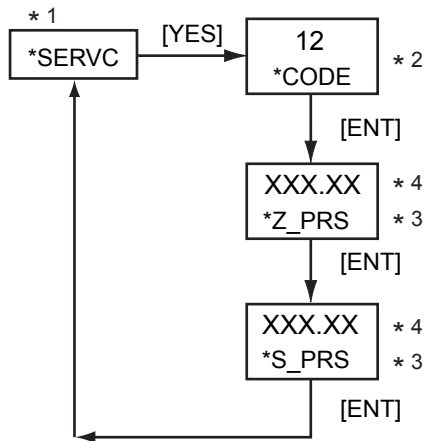

F0715.ai

- *1: See "Figure 7.4 Process at the Setting Level" on page 7-10.
- *2: Enter the code number.
- *3: Set a value using the [>], [^] and [ENT] keys.
If you enter a value that exceeds the limits, the display shows [*OVER].
Press the [YES] or [NO] key to re-set the value.
- *4: The position of the decimal point changes depending on the setting of CODE 20.
If the code is set to "0" (kPa), the reading is XXX.XX;
if the code is set to "1" (MPa), the reading is X.XXXX;
if the code is set to "2" (psi), the reading is XX.XXX.

Figure 7.15 Setting of Gas Pressure

CODE 14: Setting for Remote Semi-automatic Calibration [*REMOT]

This setting determines whether or not the measuring range of the replacement (substituents-concentration) meter is selected remotely.

If remote range selection is to be carried out, you must wire the contact input.

- Disable: 0
- Enable: 1

If the code is set to "1", the analyzer selects:

- the "AIR in CO₂" range, if the contact input is open.
- the "H₂ in CO₂" range, if the contact input is closed.

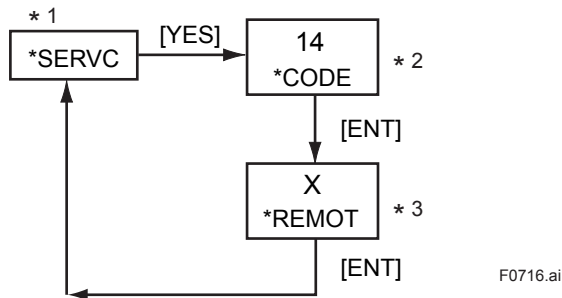

- *1: See "Figure 7.4 Process at the Setting Level" on page 7-10.
- *2: Enter the code number.
- *3: Set a value using the [>], [^] and [ENT] keys.

Figure 7.16 Setting for Remote Semi-automatic Calibration

CODE 20: Selection of Pressure Unit [*PRES.U]

This setting defines the pressure unit for the gas pressure transmitter.

- kPa: 0
- MPa: 1
- psi : 2

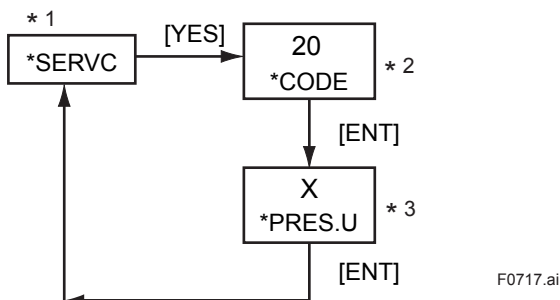

- *1: See "Figure 7.4 Process at the Setting Level" on page 7-10.
- *2: Enter the code number.
- *3: Set a value using the [>], [^] and [ENT] keys.

Figure 7.17 Selection of Pressure Unit

CODE 21: Selection of Density Unit [*DENS.U]

This setting defines the density unit for the gas density meter.

- kg/m³: 0
- lb/ft³: 1

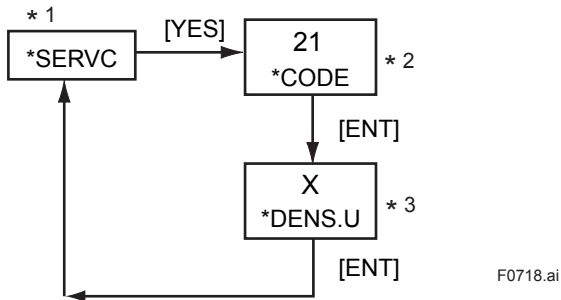

- *1: See "Figure 7.4 Process at the Setting Level" on page 7-10.
- *2: Enter the code number.
- *3: Set a value using the [>], [^] and [ENT] keys.

Figure 7.18 Selection of Density Unit

CODE 23: Selection of Temperature Unit [*TEMP.U]

This setting defines the temperature unit for the gas density meter.

- °C: 0
- °F: 1

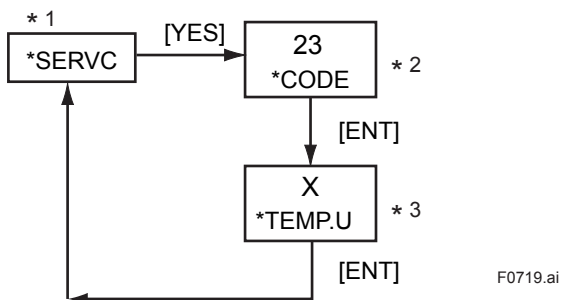

- *1: See "Figure 7.4 Process at the Setting Level" on page 7-10.
- *2: Enter the code number.
- *3: Set a value using the [>], [^] and [ENT] keys.

Figure 7.19 Selection of Temperature Unit

CODE 31: Showing/Hiding of Negative Measured Values [*MINUS]

This setting determines whether negative measured values (-) should be shown or hidden.

- Show: 0
- Hide: 1

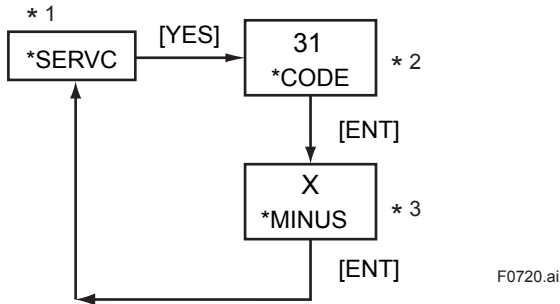

*1: See "Figure 7.4 Process at the Setting Level" on page 7-10.

*2: Enter the code number.

*3: Set a value using the [>], [^] and [ENT] keys.

Figure 7.20 Showing/Hiding of Negative Measured Values

CODE 40: Indication of Calibration Coefficients (Read-only)

This setting determines the calibration coefficients to be indicated.

- (a) Zero [*C_K_Z]: indicated as SX.XXXX
- (b) Span [*C_K_S]: indicated as X.XXXX

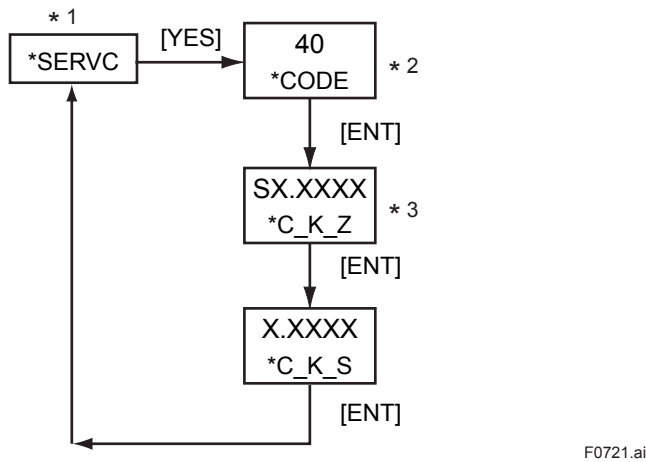

*1: See "Figure 7.4 Process at the Setting Level" on page 7-10.

*2: Enter the code number.

*3: By pressing the [ENT] key, the next indication is displayed.
This parameter does not accept the [>] and [^] key input.

Figure 7.21 Indication of Calibration Coefficients

CODE 41: Indication of Oscillation Frequency (Read-only)

This setting determines the F2 and F4 oscillation frequencies coefficients to be indicated.

- (a) Indication of frequency F2 (kHz) [*F2.KHZ]: indicated as X.XXXXX
- (b) Indication of frequency F4 (kHz) [*F4.KHZ]: indicated as X.XXXXX
- (c) Indication of frequency ratio (kHz) [*F2/F4]: indicated as X.XXXXX

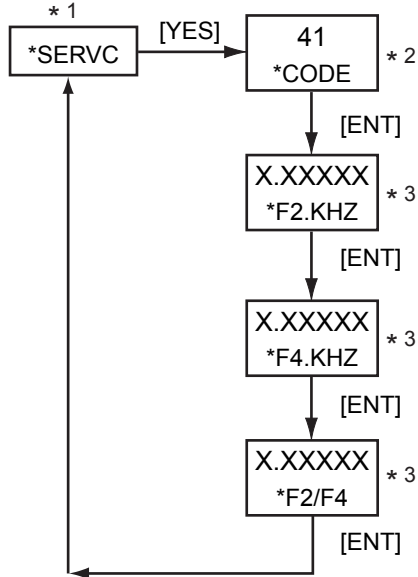

F0722.ai

- *1: See "Figure 7.4 Process at the Setting Level" on page 7-10.
- *2: Enter the code number.
- *3: By pressing the [ENT] key, the next indication is displayed.
This parameter does not accept the [>] and [^] key input.

Figure 7.22 Indication of Oscillation Frequency

CODE 42: Indication of Software Version [*REV] (Read-only)

This setting allows the software version to be confirmed (indicated).

Indicated as X.XX

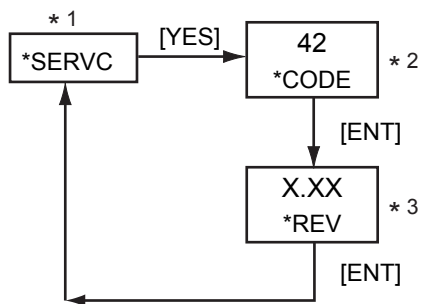

F0723.ai

- *1: See "Figure 7.4 Process at the Setting Level" on page 7-10.
- *2: Enter the code number.
- *3: Pressing the [ENT] key returns to the service level with the indication [*SERVC].
This parameter does not accept the [>] and [^] key input.

Figure 7.23 Indication of Software Version

CODE 43: Setting of High-resolution Mode [*S_CYC]

This setting selects between the normal mode and the high-resolution mode.

- Normal mode: 0
- High-resolution mode: 1

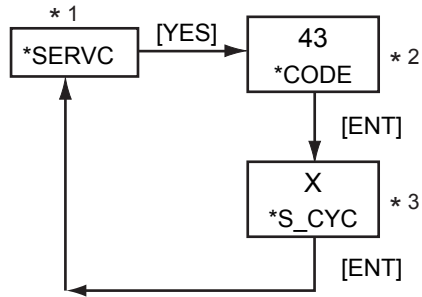

F0724.ai

- *1: See "Figure 7.4 Process at the Setting Level" on page 7-10.
- *2: Enter the code number.
- *3: Set a value by using the [>], [^] and [ENT] keys.

Figure7.24 Setting of High-resolution Mode

CODE 44: Setting of PASSWORD [*PASS]

This setting defines the password.

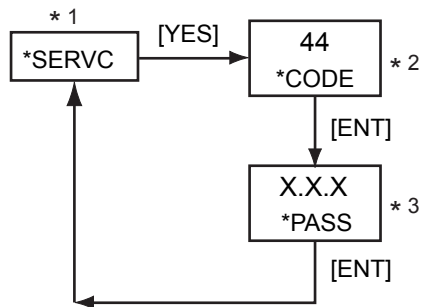

F0725

- *1: See "Figure 7.4 Process at the Setting Level" on page 7-10.
- *2: Enter the code number.
- *3: Set a value by using the [>], [^] and [ENT] keys.

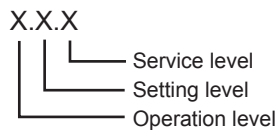

Note: Password entry request (if a password is set)
 At the operation level, a request is issued when the [MODE] key is pressed in the measurement mode. At the setting level, it is issued when the [*] key is pressed. At the service level, it is issued when the [YES] key is pressed with [*SERVC] displayed.

Password	
X (Setting)	Contents
(0)	(No setting)
1	111
2	333
3	777
4	888
5	123
6	957
7	331
8	546
9	847

Figure 7.25 Setting of Password

CODE 45: Selecting Battery alarm detection [*BAT]

This setting determines whether or not battery alarm is detection.

- Non detection: 0
- Detection: 1

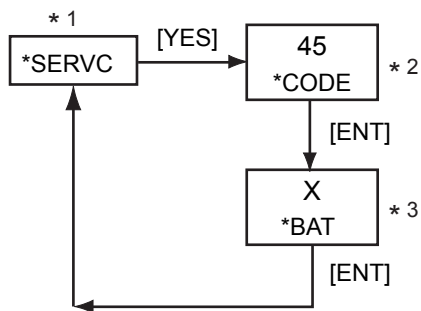

F0726

*1: See "Figure 7.4 Process at the Setting Level" on page 7-10.

*2: Enter the code number.

*3: Set a value by using the [>], [^] and [ENT] keys.

Figure 7.26 Selecting Battery alarm detection

CODE 50: Selecting the instruments [*MODEL]

This setting defines the model.

- Density meter: 0
- Calorie meter: 1
- Hydrogen purity, replacement meter : 2

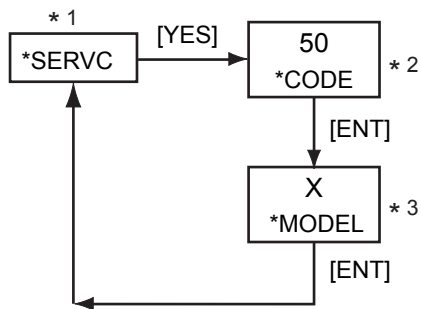

F0727

*1: See "Figure 7.4 Process at the Setting Level" on page 7-10.

*2: Enter the code number.

*3: Set a value by using the [>], [^] and [ENT] keys.

Figure 7.27 Selecting the instruments

CODE 82: Setting Detector Constant

This setting defines the detector constant.

**CAUTION**

The instruments may not only work improperly but also big problems occur unless the detector constants entered incorrectly. Do carefully and precisely when enter the detector constants into converter.

1. The GD402 gas density meter is shipped after adjusting the detector and converter in pairs. When installation, confirm the converter serial number described on the label of detector so that combines converter and detector correctly. If mismatched in pairs, converter may be out of order. If combined correctly, no need to enter the detector constants again, as converter has been adjusted with the constants in factory.
 2. When supply converter or detector individually, enter the detector constants, described on inside the lid of the GD40, into the converter so that the GD402 is going to be well.
-

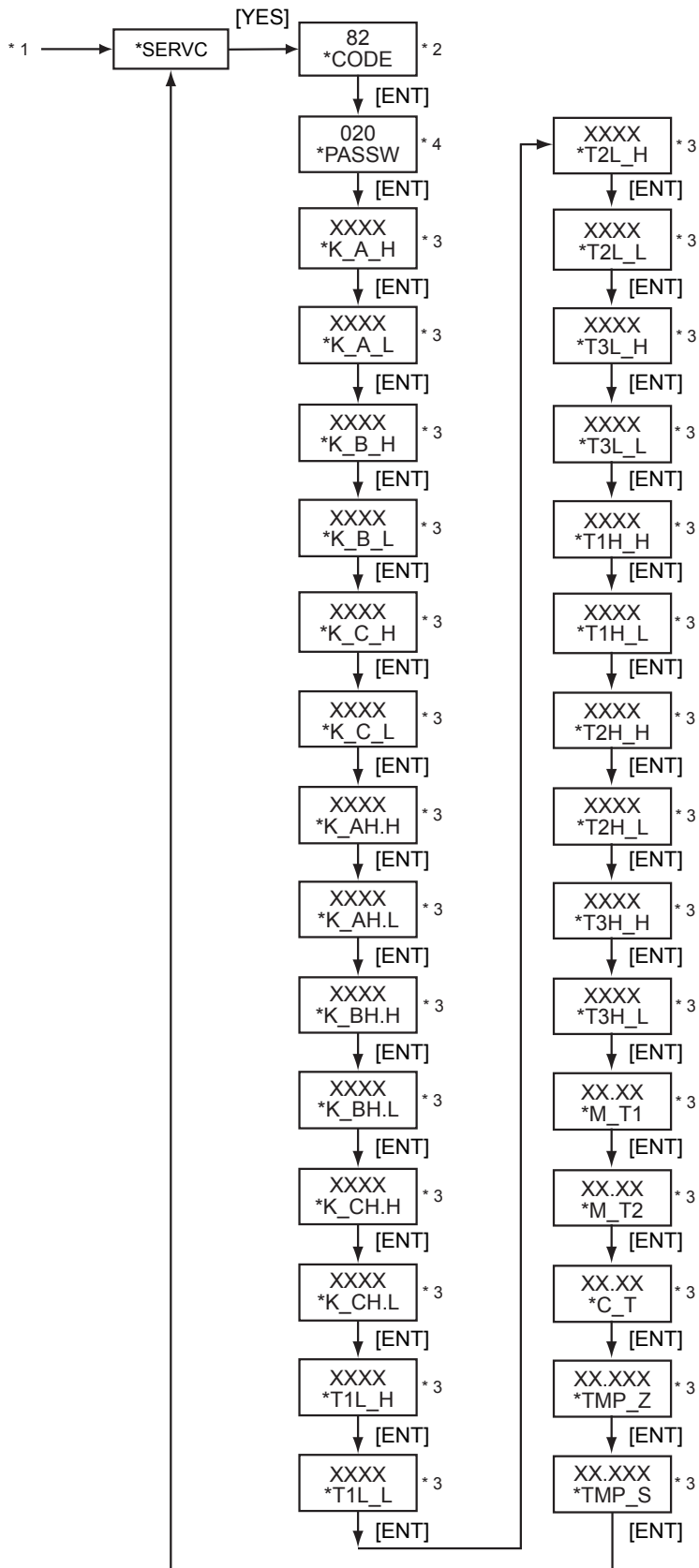

F0728

- *1: See "Figure 7.4 Process at the Setting Level" on page 7-10.
- *2: Enter the code number.
- *3: Set a value using the [>], [^] and [ENT] keys.
Detector Constants are described inside the lid of detector GD40.
- *4: Set the PASSWORD.

Figure 7.28 Setting Detector Constant

8. DENSITY / CALIBRATION PROCEDURE

This chapter describes how to calibrate of Density meter.

If select Calorie meter, see Chapter 9.

If select Hydrogen purity meter, see Chapter 10.

Zero and span calibration can be carried out using standard gases (zero and span gases). Three modes are available for calibration: automatic, semi-automatic (remote semi-automatic) and manual. Even if automatic calibration is enabled in the parameter setting, you can interrupt the system with either the semi-automatic or manual mode of calibration. The following explains the basic procedure and operation used in calibration.

8.1 Basic Calibration Procedure

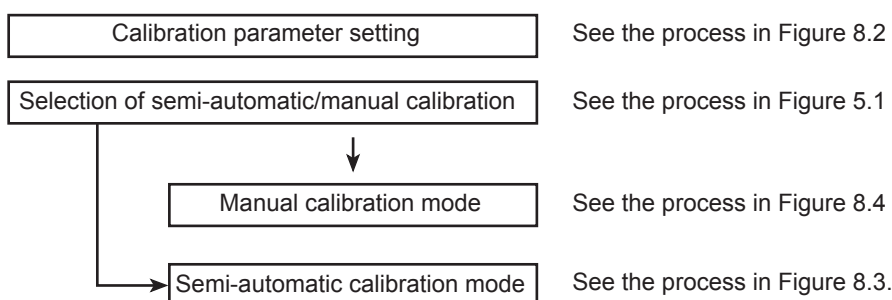

F0801.ai

8.2 Preparation for Calibration

Prepare for calibration during the initial operation of the analyzer, by carrying out the following.

- At the operation level, set the parameters for semi-automatic and manual calibration. Also set the valve-operation parameter for switching between gases to check the valve performance.
- At the setting level, set the calibration data (zero- and span-point values, status of output during calibration etc.)
- At the service level, determine whether automatic and remote semi-automatic calibrations are enabled or disabled in CODE 13 and 14. Set the calibration data (selection of calibration item, calibration time, stabilization time, etc.) in CODE 15.

8.2.1 Setting Type of Calibration and Checking Valve Operation

(1) Operations to Set the Semi-automatic and Manual Calibration

In the measurement mode, press the [MODE] key, (if password is selected, enter the password (XXX) (See section “4.2 Setting Lists”),) and select the desired type of calibration.

- To select semi-automatic calibration, show [SEM.CAL] and press the [YES] key.
- To select manual calibration, show [MAN.CAL] and press the [YES] key.

For details on this process, see Figure 5.1.

(2) Operations for Setting the Automatic/Remote Semi-automatic Calibration

- Selection for automatic calibration [*AUTO.C]
At the service level, select CODE 13.
 - Disable: 0
 - Enable: 1
- Selection for remote semi-automatic calibration [*REMOT]
At the service level, select CODE 14.
 - Disable: 0
 - Enable: 1

(3) Valve Check

Check the performance of valves according to the “valve operation flowchart” at the operation level.

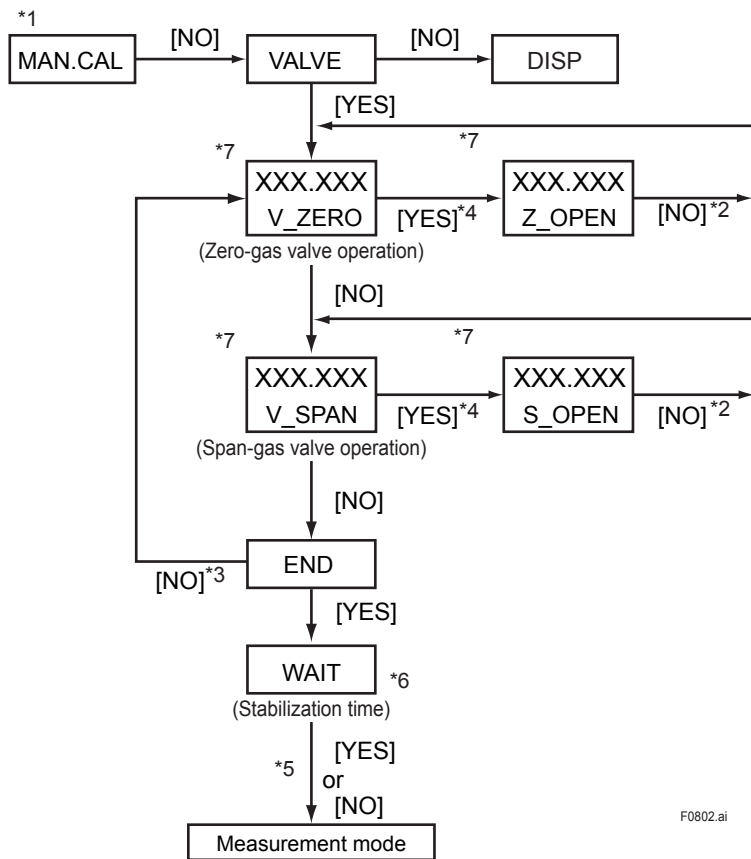

- *1: See "Figure 5.1 Modes of Operation Level" on page 5-8.
- *2: Press the [NO] key to return to the parameter for sample gas.
- *3: Using the [NO] key, show [V_ZERO], [V_SPAN] and [END] in succession.
- *4: Using the [YES] key, open the zero-gas or span-gas value to read the measured value at the point.
- *5: Press the [YES] key to go into the measurement mode state after a given stabilization time elapses; press the [NO] key to go into that state immediately.
- *6: This step is skipped if no valve was opened.
- *7: The display shows the same data item to be measured as the one in the measurement mode.

Figure 8.1 Valve Operation Mode

8.2.2 Setting Calibration Data

To set calibration data, press the [*] key in the measurement mode, (when password is selected, enter the password (XXX),) and select the parameter [*CAL.DT]. See Figure 5.4 for the process at the setting level.

- (a) Zero-point density [*Z_DNS]
 - Configurable range : 0.0000 to 6.0000 (kg/m³)
 - 0.00000 to 0.40000 (lb/ft³)
- (b) Span-point density [*S_DNS]
 - Configurable range : 0.0000 to 6.0000 (kg/m³)
 - 0.00000 to 0.40000 (lb/ft³)
- (c) Output hold value during calibration [*C_HLD]
 - Disable: 0
 - Enable: 1
 - Enable (preset value): 2
- (d) Setting of preset value [*PR.SET]
 - Configurable range: -10.0 to 110.0
 - (Applies only if item (c) above is set to "2".)

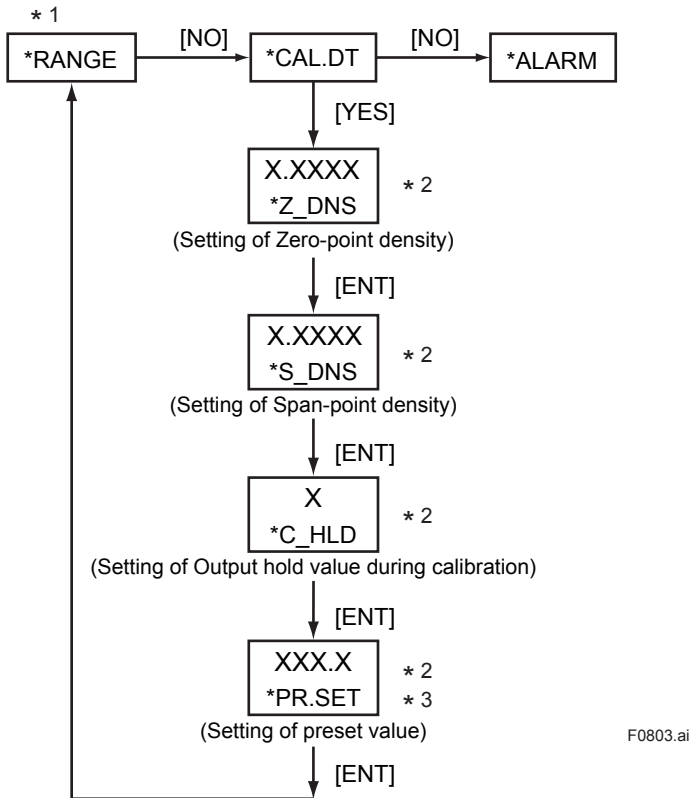

*1: See "Figure 5.3 Process at the Setting Level" on page 5-10.
 *2: Set a value using the [>], [^] and [ENT] keys.
 If you enter a value that exceeds the limits, the display shows [*OVER].
 Press the [YES] or [NO] key to re-set the value.
 *3: This step is skipped if the parameter [*C_HLD] is set to a value other than "2".

Figure 8.2 Calibration Parameter Setting Mode

8.3 Calibration

8.3.1 Semi-automatic Calibration

In this mode of calibration, you can carry out one-touch calibration. To use this feature, you must observe the following instructions.

- The analyzer needs solenoid valves for controlling the calibration gases (zero and span gases). Connect the solenoid valves with utmost care to ensure that there is no gas leakage in the system.
- Install the calibration gas cylinders in a location close to the GD40□ detector. If the detector needs to be installed in an explosion-hazardous area, the solenoid valves being used must also be protected against explosion.
- The contacts for controlling solenoid valves are built in the GD402T, GD402V, GD402R converter. It is the user's responsibility to supply power to drive the contacts. You must install a switch and a fuse along the power line. Note that the contacts are rated at 250 V AC/3 A or 30 V DC/3 A.

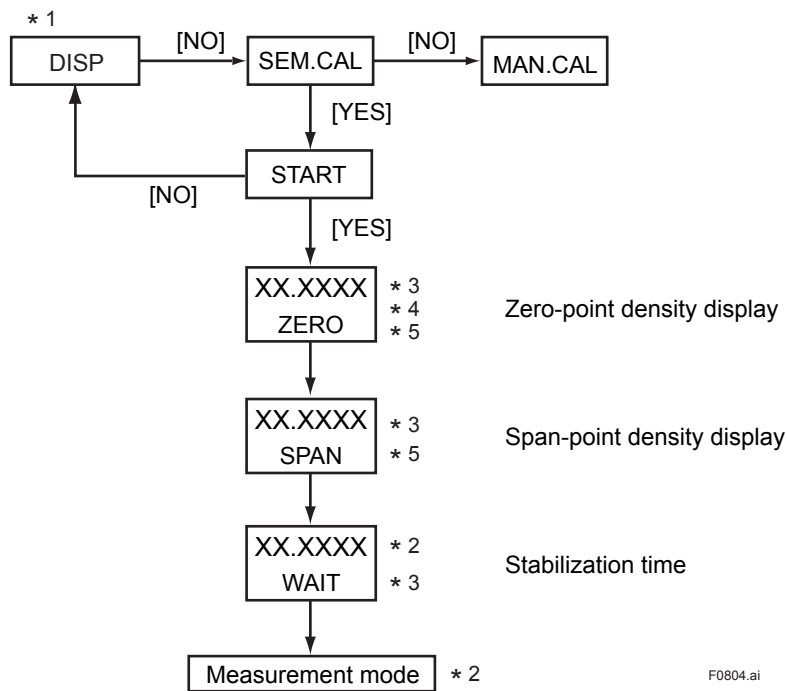

*1: See "Figure 5.1 Modes of Operation Level" on page 5-8.
*2: If a calibration data error [ALM.10] occurs, the display alternates between the [WAIT] and [ALM.10] indications. The [ALM.10] indication still remains on display even after the mode move to the measurement mode. This error message does not disappear until normally ending in re-calibration or resetting the analyzer.
*3: The values are operated and the calibration data are read at the time setpoint (calibration time) which is defined in the mode for setting automatics/semi-automatic calibration data in CODE 15. The display always shows the corrected density.
*4: During automatic calibration, the display shows the same data items as those of the [ZERO] and subsequent indications.
*5: When pressing the [MODE] key during [ZERO] or [SPAN] status, the [WAIT] appears on the display. When pressing the [MODE] key once again, the analyzer returns to the measurement mode. (This operation means you have cancelled automatic/semi-automatic calibration.)

Figure 8.3 Semi-automatic Calibration Mode

8.3.2 Manual Calibration

In this mode of calibration, you visually make sure the reading has settled, and then confirm the reading manually (by pressing the [ENT] key). There are two ways to switch between the zero, span and sample gases: by using manually-operated valves or by using solenoid valves. When switching between the gases using solenoid valves, follow the instructions on valve installation in Subsection 8.3.1.

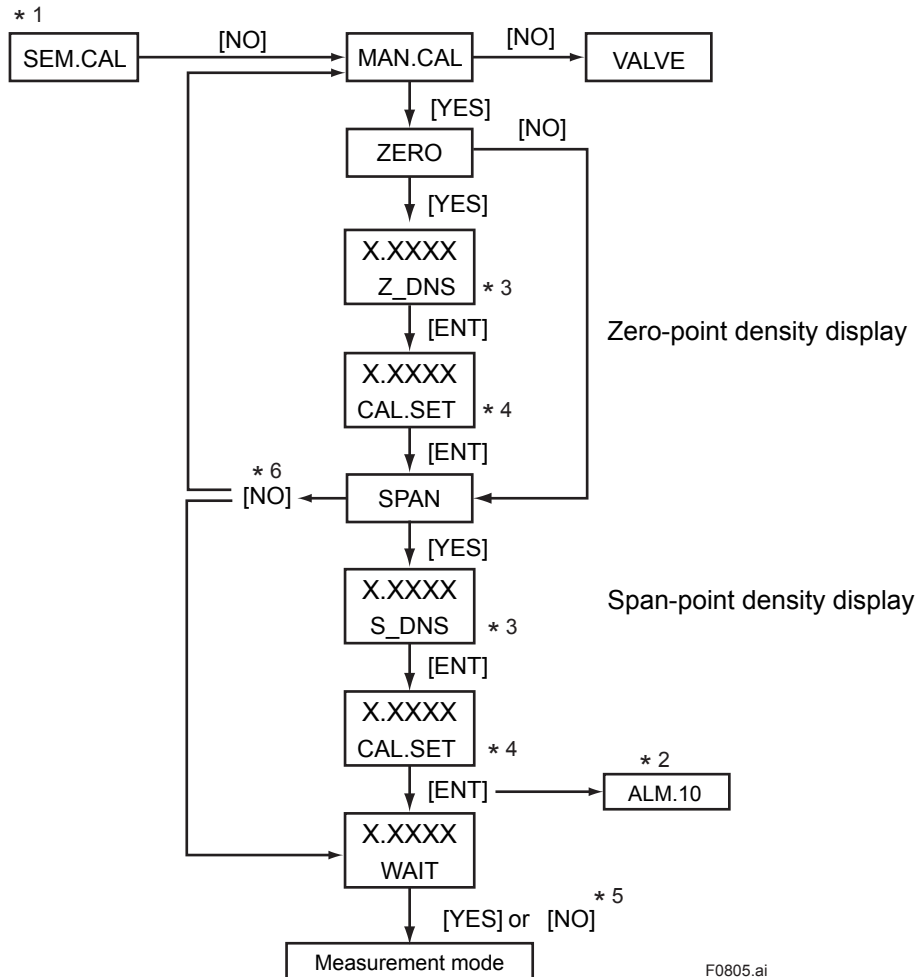

- *1: See "Figure 5.1 Modes of Operational Level" on page 5-8.
- *2: If a calibration data error occurs, the display shows [ALM.10]. Pressing the [YES] or [NO] key returns the display to the [MAN.CAL].
- *3: Set a desired value by using the [>], [^] and [ENT] keys.
- *4: When the reading settles, press the [ENT] key to confirm your calibration. This parameter does not accept input with the [>] and [^] keys. If you press the [MODE] key (for ESCAPE) after this parameter appears, the display shows [WAIT]. The display always shows the corrected density.
- *5: Press the [YES] key to go into the measurement mode status after a given stabilization time elapses: Press the [NO] key to go into the state immediately.
- *6: In case of pressing the [NO] key after skipping zero calibration (by pressing [NO] key in the ZERO status), the analyzer returns to [MAN.CAL]. In case of pressing the [NO] key after finishing zero calibration, the analyzer goes to [WAIT] status.

Figure 8.4 Manual Calibration Mode

8.3.3 Automatic Calibration

This mode of calibration takes effect when you select “enable” for automatic calibration in CODE 13 - [*AUTO.C] - at the service level. Even during automatic calibration, you can interrupt the system with the semi-automatic or manual mode of calibration. One cycle of automatic calibration is skipped, however, if the time of automatic calibration arrives when semi-automatic calibration is in progress.

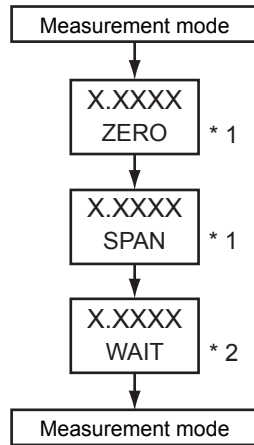

F0806.ai

*1 : Pressing the [MODE] key, change it to display [WAIT] indication.

*2 : Pressing the [MODE] key, once again returns it measuring mode.

Figure 8.5 Automatic Calibration Mode

9. CALORIE /CALIBRATION PROCEDURE

This chapter describes how to calibrate of Calorie meter.
If select Density meter, see Chapter 8.
If select Hydrogen purity meter, see Chapter 10.

Zero and span calibration can be carried out using standard gases (zero and span gases). Three modes are available for calibration: automatic, semi-automatic (remote semi-automatic) and manual. Even if automatic calibration is enabled in the parameter setting, you can interrupt the system with either the semi-automatic or manual mode of calibration. The following explains the basic procedure and operation used in calibration.

9.1 Basic Calibration Procedure

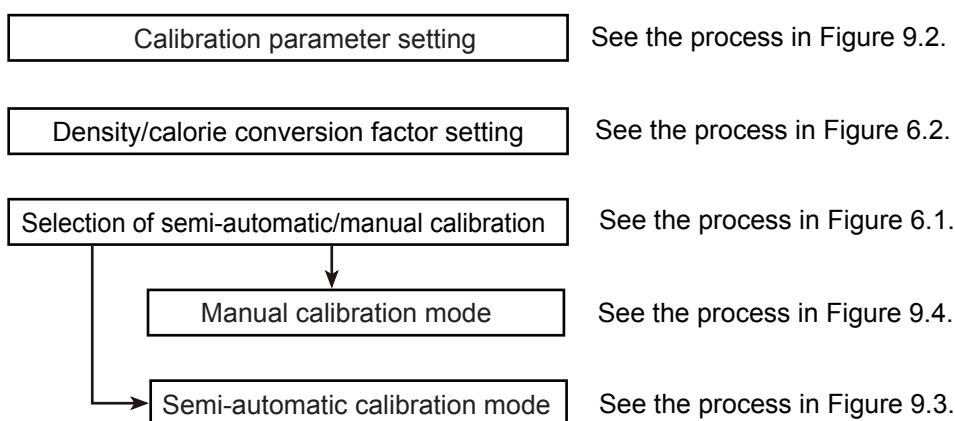

F0901.ai

9.2 Preparation for Calibration

Prepare for calibration during the initial operation of the analyzer, by carrying out the following.

- At the operation level, set the parameters for semi-automatic and manual calibration. Also set the valve-operation parameter for switching between gases to check the valve performance.
- At the setting level, set the calibration data (zero- and span-point values, status of output during calibration etc.)
- At the service level, determine whether automatic and remote semi-automatic calibrations are enabled or disabled in CODE 13 and 14. Set the calibration data (selection of calibration item, calibration time, stabilization time, etc.) in CODE 15.

9.2.1 Setting Type of Calibration and Checking Valve Operation

(1) Operations to Set the Semi-automatic and Manual Calibration

In the measurement mode, press the [MODE] key, (if password is selected, enter the password (XXX) (See section “4.2 Setting Lists”),) and select the desired type of calibration.

- To select semi-automatic calibration, show [SEM.CAL] and press the [YES] key.
- To select manual calibration, show [MAN.CAL] and press the [YES] key.

For details on this process, see Figure 6.1.

(2) Operations for Setting the Automatic/Remote Semi-automatic Calibration

- Selection for automatic calibration [*AUTO.C]
At the service level, select CODE 13.
 - Disable: 0
 - Enable: 1
- Selection for remote semi-automatic calibration [*REMOT]
At the service level, select CODE 14.
 - Disable: 0
 - Enable: 1

(3) Valve Check

Check the performance of valves according to the “valve operation flowchart” at the operation level.

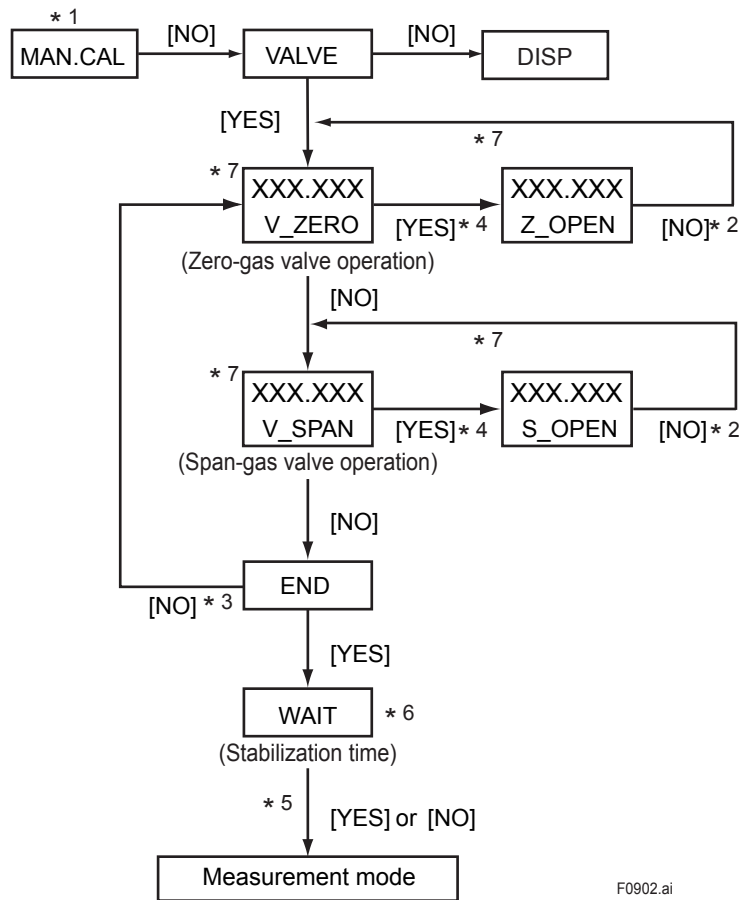

F0902.ai

- *1: See "Figure 6.1 Modes of Operation Level" on page 6-8.
- *2: Press the [NO] key to return to the parameter for sample gas.
- *3: Using the [NO] key, show [V_ZERO], [V_SPAN] and [END] in succession.
- *4: Using the [YES] key, open the zero-gas or span-gas value to read the measured value at the point.
- *5: Press the [YES] key to go into the measurement mode state after a given stabilization time elapses; press the [NO] key to go into that state immediately.
- *6: This step is skipped if no valve was opened.
- *7: The display shows the same data item to be measured as the one in the measurement mode.

Figure 9.1 Valve Operation Mode

9.2.2 Setting Calibration Data

To set calibration data, press the [*] key in the measurement mode, (when password is selected, enter the password (XXX),) and select the parameter [*CAL.DT]. See Figure 6.4 for the process at the setting level.

(a) Zero-point calorific value [*Z_CAL]

Configurable range : 000.000 to 133.000 (MJ/m³)
0.0000 to 3.5000 (kBTU/ft³)

(b) Zero-point density [*Z_DNS]

Configurable range : 0.0000 to 6.0000 (kg/m³)
0.00000 to 0.40000 (lb/ft³)

(c) Span-point calorific value [*S_CAL]

Configurable range : 000.000 to 133.000 (MJ/m³)
0.0000 to 3.5000 (kBTU/ft³)

(d) Span-point density [*S_DNS]

Configurable range : 0.0000 to 6.0000 (kg/m³)
0.00000 to 0.40000 (lb/ft³)

(e) Output hold value during calibration [*C_HLD]

- Disable: 0
- Enable: 1
- Enable (preset value): 2

(f) Setting of preset value [*PR.SET]

Configurable rang : -10.0 to 110.0

(Applies only if item (e) above is set to "2".)

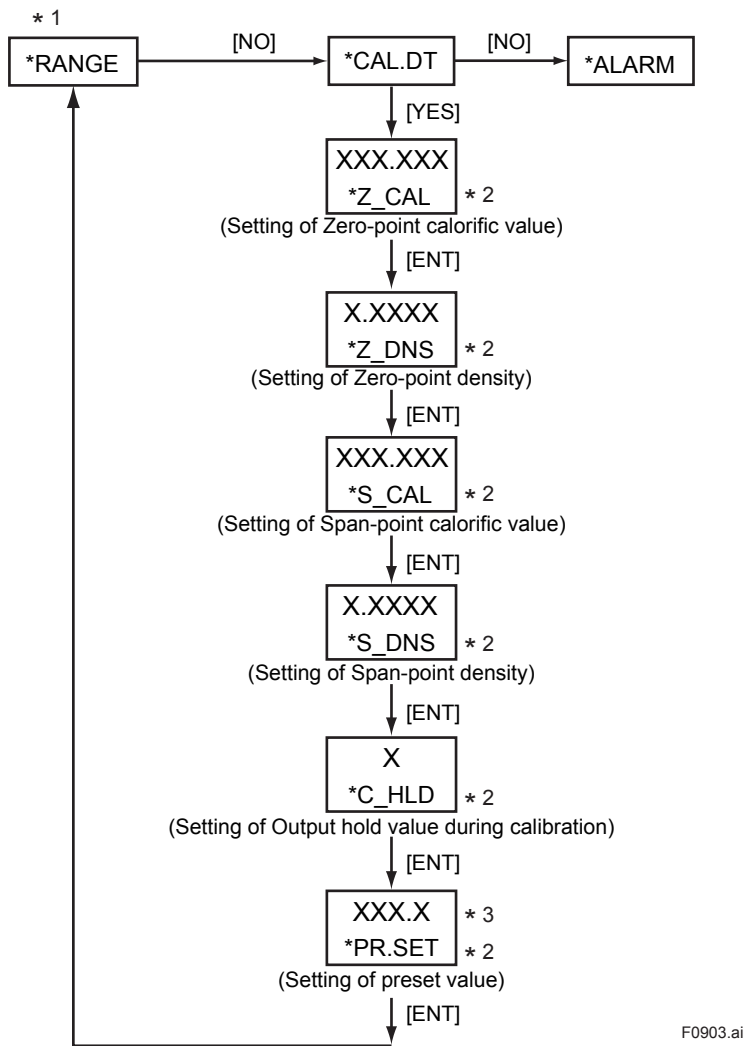

F0903.ai

*1: See "Figure 6.4 Process at the Setting Level" on page 6-12.

*2: Set a value using the [>], [^] and [ENT] keys.

If you enter a value that exceeds the limits, the display shows [*OVER].
Press the [YES] or [NO] key to re-set the value.

*3: This step is skipped if the parameter [*C_HLD] is set to a value other than "2".

Figure 9.2 Calibration Parameter Setting Mode

9.3 Calibration

9.3.1 Semi-automatic Calibration

In this mode of calibration, you can carry out one-touch calibration. To use this feature, you must observe the following instructions.

- The analyzer needs solenoid valves for controlling the calibration gases (zero and span gases). Connect the solenoid valves with utmost care to ensure that there is no gas leakage in the system.
- Install the calibration gas cylinders in a location close to the GD40□ detector. If the detector needs to be installed in an explosion-hazardous area, the solenoid valves being used must also be protected against explosion.
- The contacts for controlling solenoid valves are built in the GD402T, GD402V, GD402R converter. It is the user's responsibility to supply power to drive the contacts. You must install a switch and a fuse along the power line. Note that the contacts are rated at 250 V AC/3 A or 30 V DC/3 A.

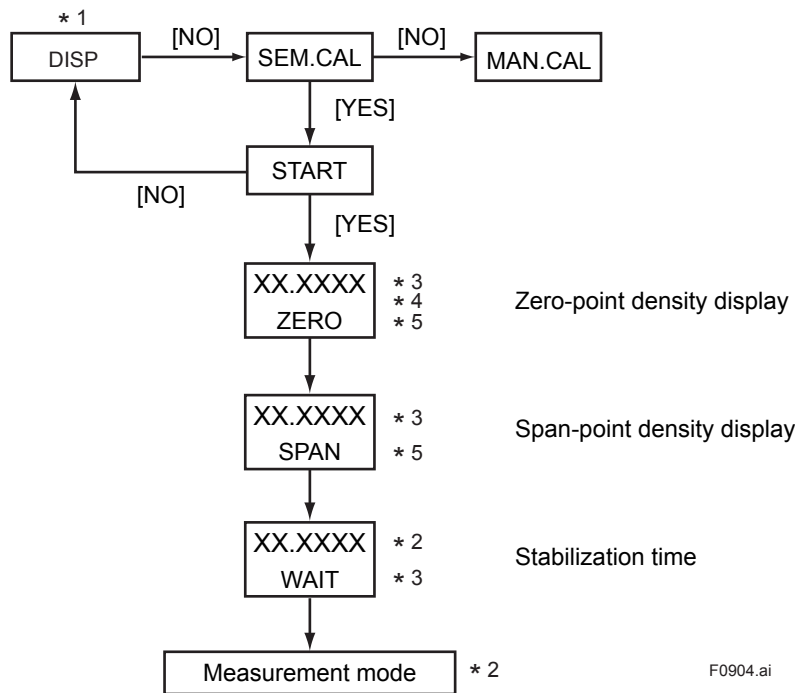

*1: See " Figure 6.1 Modes of Operation Level" on page 6-8.
 *2: If a calibration data error [ALM.10] occurs, the display alternates between the [WAIT] and [ALM.10] indications. The [ALM.10] indication still remains on display even after the mode move to the measurement mode. This error message does not disappear until normally ending in re-calibration or resetting the analyzer.
 *3: The values are operated and the calibration data are read at the time setpoint (calibration time) which is defined in the mode for setting automatics/semi-automatic calibration data in CODE 15. The display always shows the corrected density.
 *4: During automatic calibration, the display shows the same data items as those of the [ZERO] and subsequent indications.
 *5: When pressing the [MODE] key during [ZERO] or [SPAN] status, the [WAIT] appears on the display. When pressing the [MODE] key once again, the analyzer returns to the measurement mode. (This operation means you have cancelled automatic/semi-automatic calibration.)

Figure 9.3 Semi-automatic Calibration Mode

9.3.2 Manual Calibration

In this mode of calibration, you visually make sure the reading has settled, and then confirm the reading manually (by pressing the [ENT] key). There are two ways to switch between the zero, span and sample gases: by using manually-operated valves or by using solenoid valves. When switching between the gases using solenoid valves, follow the instructions on valve installation in Subsection 9.3.1.

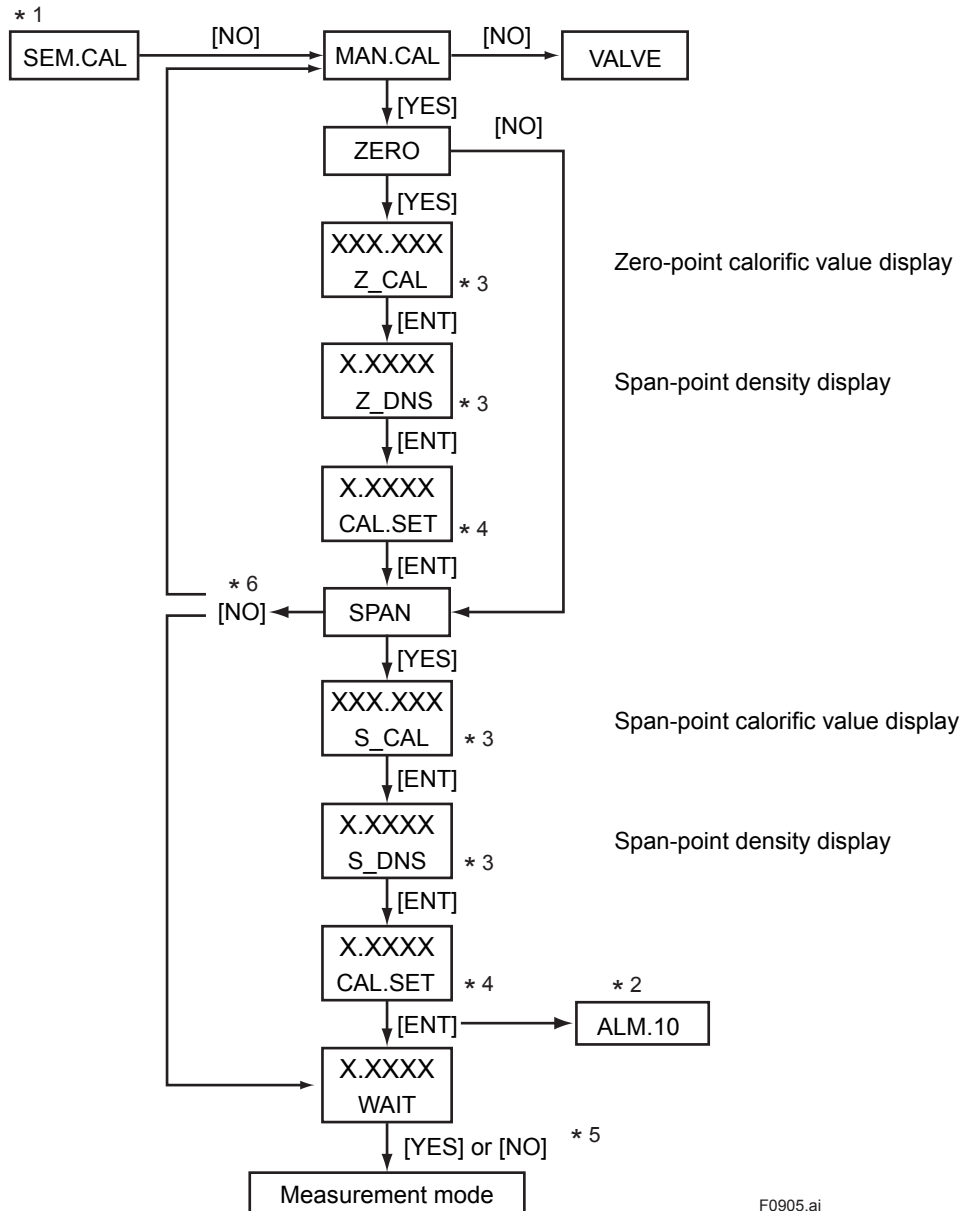

- *1: See "Figure 6.1 Modes of Operational Level" on page 6-8.
- *2: If a calibration data error occurs, the display shows [ALM.10]. Pressing the [YES] or [NO] key returns the display to the [MAN.CAL].
- *3: Set a desired value by using the [>], [^] and [ENT] keys.
- *4: When the reading settles, press the [ENT] key to confirm your calibration. This parameter does not accept input with the [>] and [^] keys. If you press the [MODE] key (for ESCAPE) after this parameter appears, the display shows [WAIT]. The display always shows the corrected density.
- *5: Press the [YES] key to go into the measurement mode status after a given stabilization time elapses: Press the [NO] key to go into that state immediately.
- *6: In case of pressing the [NO] key after skipping zero calibration (by pressing [NO] key in the [ZERO] status), the analyzer returns to [MAN.CAL]. In case of pressing the [NO] key after finishing zero calibration, the analyzer goes to [WAIT] status.

Figure 9.4 Manual Calibration Mode

9.3.3 Automatic Calibration

This mode of calibration takes effect when you select “enable” for automatic calibration in CODE 13 - [*AUTO.C] - at the service level. Even during automatic calibration, you can interrupt the system with the semi-automatic or manual mode of calibration. One cycle of automatic calibration is skipped, however, if the time of automatic calibration arrives when semi-automatic calibration is in progress.

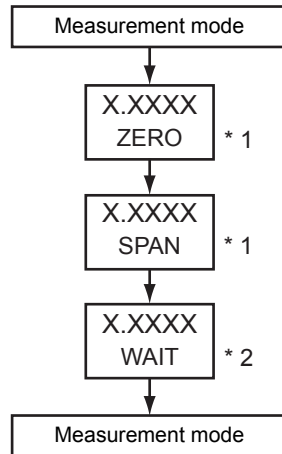

F0906.ai

*1 : Pressing the [MODE] key, change it to display [WAIT] indication.

*2 : Pressing the [MODE] key, once again returns it measuring mode.

Figure 9.5 Automatic Calibration Mode

10. HYDROGEN PURITY / CALIBRATION PROCEDURE

This chapter describes how to calibrate of Hydrogen purity meter.
 If select Density meter, see Chapter 8.
 If select Calorie meter, see Chapter 9.

Zero and span calibration can be carried out using standard gases (zero and span gases). The analyzer uses hydrogen (100%) as the zero gas and carbon dioxide (100%) as the span gas. The analyzer is designed so that calibration is done manually. The basic calibration procedures and operations are as follows.

10.1 Basic Calibration Procedure

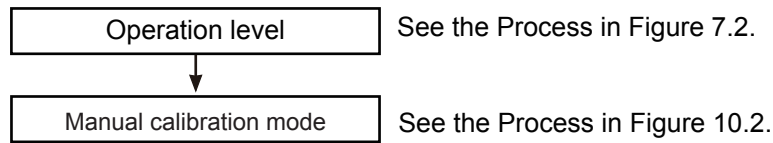

F1001.ai

10.2 Preparation for Calibration

Prepare for calibration during the initial operation of the analyzer by entering manual calibration at the operation level.

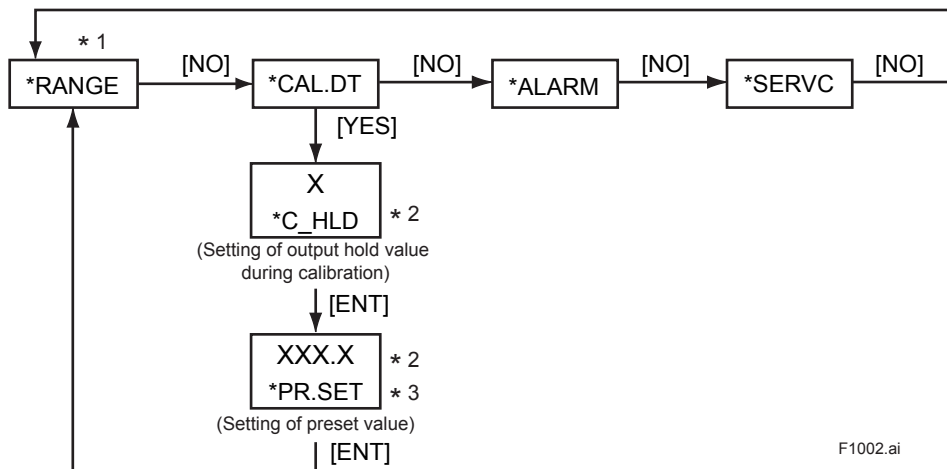

F1002.ai

- *1: See "Figure 7.4 Process at the Setting Level" on page 7-10.
- *2: Set a value using the [>], [^] and [ENT] keys.
 If you enter a value that exceeds the limits, the display shows [*OVER].
 Press the [YES] or [NO] key to re-set the value.
- *3: This step is skipped if the parameter [*C_HLD] is set to a value other than "2".

Figure 10.1 Calibration Parameter Setting Mode

10.3 Calibration

In the manual calibration mode, visually check that the reading has settled, and then confirm the reading manually (by pressing the [ENT] key).

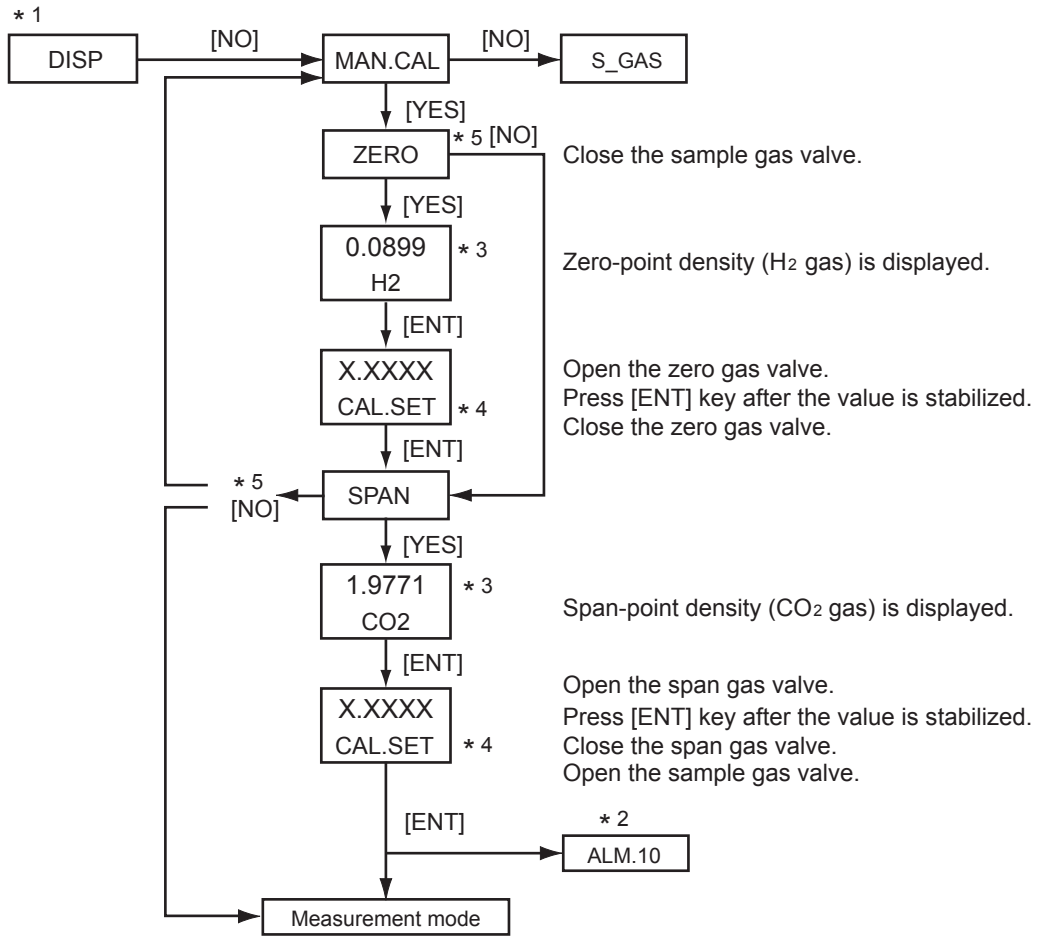

- *1: See "Figure 7.2 Modes of Operational Level" on page 7-7.
- *2: If a calibration data error occurs, the display shows ALM.10 .
Pressing the [YES] or [NO] key returns this status to the [MAN.CAL].
- *3: The displayed value is fixed. It cannot be set.
- *4: When the reading settles, press the [ENT] key to confirm your calibration.
This parameter does not accept input with the [>] and [^] keys.
The display always shows the corrected density.
- *5: Pressing the [NO] key for both the [ZERO] and [SPAN] indications returns this status to the [MAN.CAL].

F1003.ai

Figure 10.2 Manual Calibration Mode

11. INSPECTION AND MAINTENANCE

To ensure the GD402 analyzer remains highly accurate with excellent operating conditions, routine inspection and maintenance is essential. Refer to the check items in this chapter to determine which items to apply in your inspection and maintenance, and check them periodically.

11.1 Routine Inspection and Maintenance

11.1.1 Checking Readings and Calibrating the Analyzer

Measure the standard gases every two to three months to check the output signal (Note: the interval varies depending on the operating conditions). If the output signal has errors, carry out zero and span calibration. For details on calibration, see Chapter 8, 9 or 10.

11.1.2 Checking the Flowrate of Sample Gas

The sample gas should be supplied to the detector at 600 mL/min \pm 10%. Periodically make sure the given flowrate is kept constant. When checking the flowrate, also make sure the piping is normal and there is no leakage of calibration gases.

11.1.3 Periodic Replacement of the Detector's O-rings

The O-rings are made from NBR, a material that is not very susceptible to plastic deformation. Their sealing capabilities therefore are not readily impaired. Any deterioration in these O-rings however can result in not only gas leakage but reduced resistance to mechanical vibration, which in turn may lead to reading errors. For this reason, it is recommended that the O-rings be replaced at a fixed interval (every two to three years). Consult Yokogawa for the replacement of O-rings.

11.1.4 Replacing the Fuse

- (1) For safety reasons, stop the power supply to the converter by switching the external breaker.
- (2) Remove the fuse from the fuse holder. Turn the holder cap counterclockwise by 90 degrees using a flat-blade screwdriver that fits the holder cap. Then, pull out the fuse together with the cap.
- (3) Check that the rating of the new fuse is correct, and put it in the fuse cap; insert the cap (and fuse) in the holder; then while pressing down, turn the cap clockwise by 90 degrees using the flat-blade screwdriver.
- (4) If the new fuse breaks too soon, the circuit may be abnormal. Contact Yokogawa in such a case.

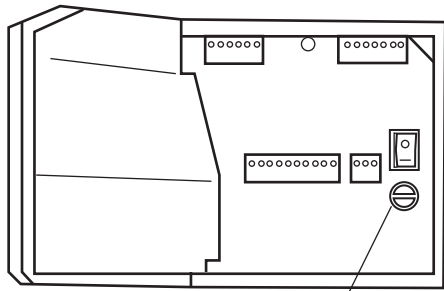

General purpose type

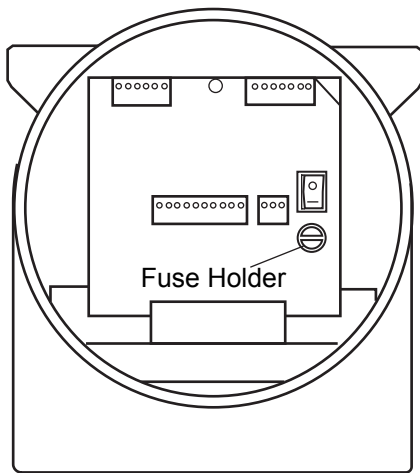

Explosion-proof type

F1101.ai

Figure 11.1 Position of the Fuse Holder

11.1.5 Cleaning

Use a clean, soft cloth when cleaning for inspection or maintenance. You can use a neutral detergent on the transparent window of the non-explosion-protected converter (weathering-resistant PVC sheet), when extremely dirty. But do not use any organic solvent.

If the device is so dirty and/or badly scratched that it affects key operation or reduces visibility, replace the case cover (part No.: K9313DW).

11.2 Inspection In Case of Failure

11.2.1 Inspecting the Analyzer in an Alarm Status

The GD402 analyzer outputs an ALARM signal through terminals 16 and 17 if a failure is detected by the self-diagnostic function during measurement. In addition, the <ALARM> lamp on the operation panel comes on and the message field shows an alarm number. The analyzer outputs no contact signal, however, if the alarm number is [ALM.09]. If a failure (alarm) is detected, take the corrective action given in Table 11.1.

Table 11.1 Corrective Actions when an Alarm Status Is Detected

Message Shown	Failure Type	Diagnostic Conditions	Corrective Actions	Message via Communication
ALM.01	High/low limit alarm against physical density	Physical density \leq Low-limit-of-physical-density alarm set-point Physical density \geq High-limit-of-physical-density	Change the high/low limits.	OUT OF DENSITY
ALM.02	High/low limit alarm against compensated density	Compensated density \leq Low-limit-of-compensated-density alarm set-point Compensated density \geq High-limit-of-compensated-density alarm set-point	Change the high/low limits.	OUT OF COMP DENSITY
ALM.03	High/low limit alarm against specific gravity	Specific gravity \leq Low-limit-of-specific gravity alarm set-point Specific gravity \geq High-limit-of-specific gravity alarm set-point	Change the high/low limits.	OUT OF SP GR
ALM.04	High/low limit alarm against calorific value	Calorific value \leq Low-limit-of-calorific-value alarm set-point Calorific value \geq High-limit-of-calorific-value alarm set-point	Change the high/low limits.	OUT OF CALORY
ALM.05	High/low limit alarm against molecular weight	Molecular weight \leq Low-limit-of-molecular weight alarm set-point Molecular weight \geq High-limit-of-molecular weight alarm set-point	Change the high/low limits.	OUT OF MOLECULE
ALM.06	High/low limit alarm against concentration	Concentration \leq Low-limit-of-concentration alarm set-point Concentration \geq High-limit-of-concentration alarm set-point	Change the high/low limits.	OUT OF CONC
ALM.07	Error in pressure input range	Zero point $-3\% \geq$ pressure Span point $+5\% \leq$ pressure Pressure ≤ 0.1 kPa	Check the sample-gas pressure and the pressure range.	OUT OF GAS PRESS
ALM.08	Abnormal sample gas temperature	-25 °C \leq sample gas temperature ≤ 80 °C	Use the sample gas within the tolerance limits.	OUT OF GAS TEMP
ALM.09	Battery failure		Contact Yokogawa service personnel.	LOW BATTERY
ALM.10	Error in calibration (zero and span points)	$-0.3000 \leq$ zero calibration value ≤ 0.3000 $0.50000 \leq$ span calibration value ≤ 1.5000	Redo calibration.	ILLEGAL CALIB

11.2.2 Inspecting the Analyzer in a FAIL Status

IN GD402, the state of terminals 18 and 19 is changed from close to open if a FAIL status is detected by the self-diagnostic function during measurement. In addition, the <FAIL> lamp on the operation panel comes on and the message field shows an error number. If a FAIL status is detected, take the corrective action given in Table 11.2.

Table 11.2 Corrective Actions when a FAIL Status Is Detected

Message Shown	Failure Type	Diagnostic Conditions	Corrective Action	Message via Communication
Err.01	Sensor oscillation shutdown	Failure to detect oscillation frequency from the detector	Reset the power supply. Contact Yokogawa service personnel.	FAULT SENSOR
Err.02	Error in sensor's oscillation frequency	Frequency F2 : out of range from 1000 to 10000Hz Frequency F4 : out of range from 4000 to 10000Hz	Reset the power supply. Contact Yokogawa service personnel.	OVER FREQUENCY
Err.03	Error in sensor's temperature	Sensor's failure to detect temperature	Contact Yokogawa service personnel.	FAULT TEMP
Err.04	A/D converter failure	Failure in A/D converter	Contact Yokogawa service personnel.	FAULT A/D
Err.05	Memory failure	Erroneous data in EEPROM/EPROM/RAM	Contact Yokogawa service personnel.	FAULT MEMORY

Customer Maintenance Parts List

GD40G, GD40T, GD40V, GD40R Gas Density Meter Detector

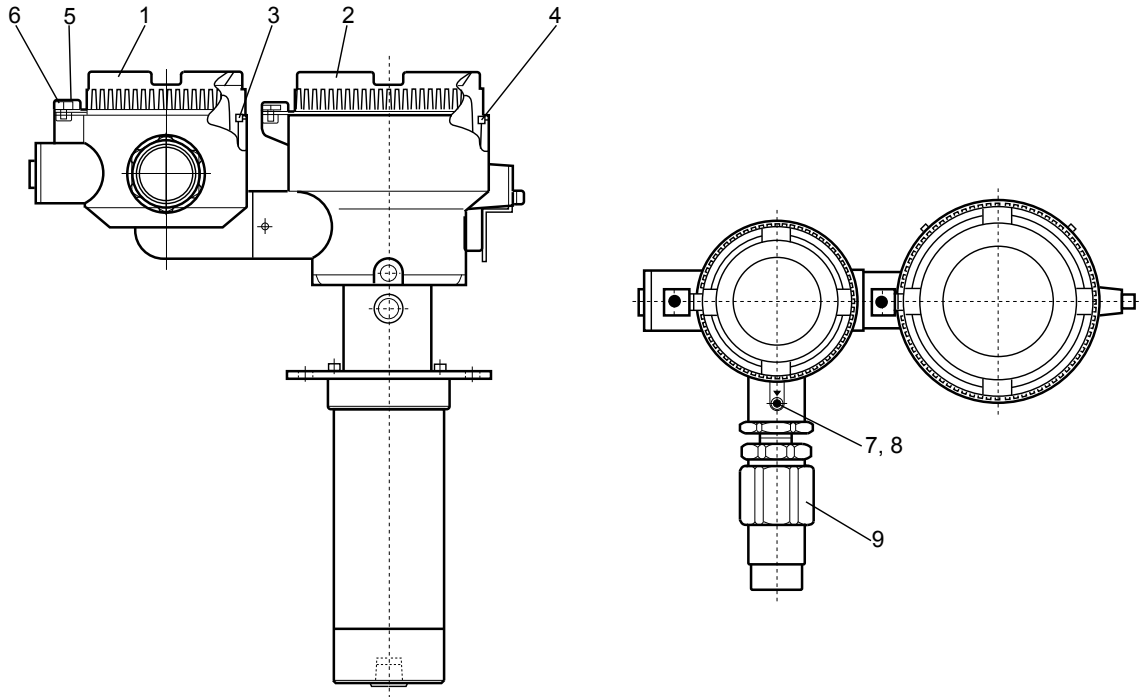

Item	Part No.	Qty	Description
1	F9301DY	1	Cover
2	F9301DQ	1	Cover
3	G9303AM	1	O-ring
4	G9303LK	1	O-ring
5	G9339AA	2	Bracket Assembly
6	Y9408ZU	2	Bolt
7	F9340AL	1	Screw
8	Y9401WL	1	Toothed Lock Washer
9	G9601AN	1	Cable Gland Assembly (only GD40R)

Customer Maintenance Parts List

GD402G Gas Density Meter Non-Explosion-proof Converter

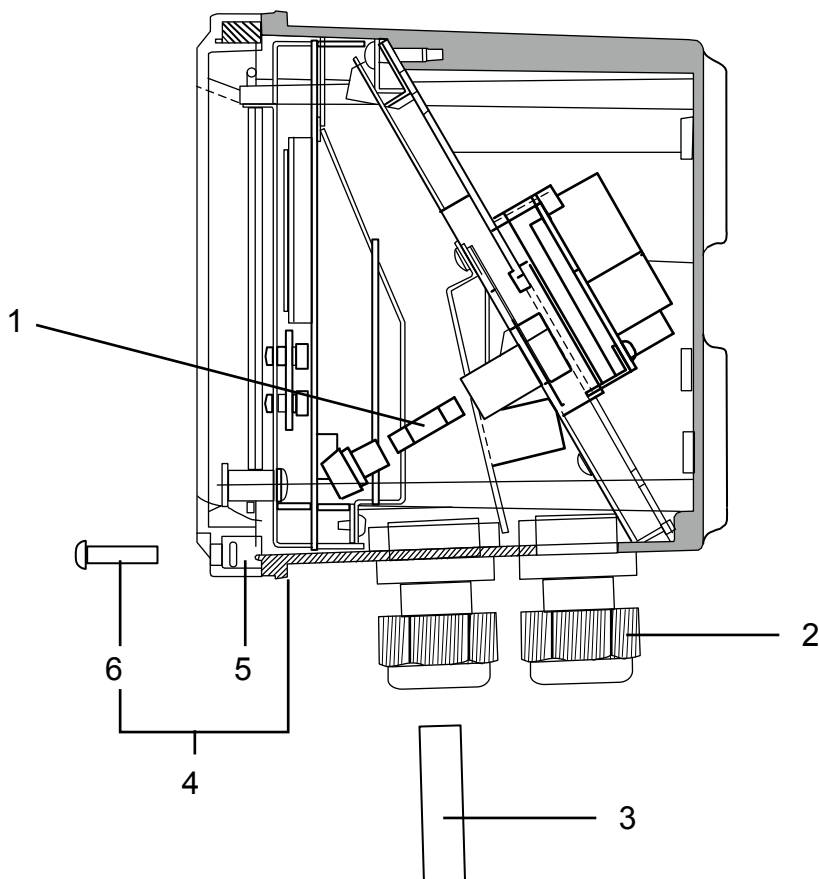

Item	Part No.	Qty	Description
1	A1109EF	1	Fuse 1.0 A (For 100 to 240 V AC)
	A1111EF	1	Fuse 2.0 A (For 24 V DC)
2	L9811FV	6	Cable Gland
3	K9334CN	6	Insert
4	K9313DW	1	Cover Assy
5	Y9101XA	4	O-Ring
6	Y9420LU	4	Screw

Customer Maintenance Parts List

GD402T, GD402V, GD402R Gas Density Meter Explosion-proof Converter

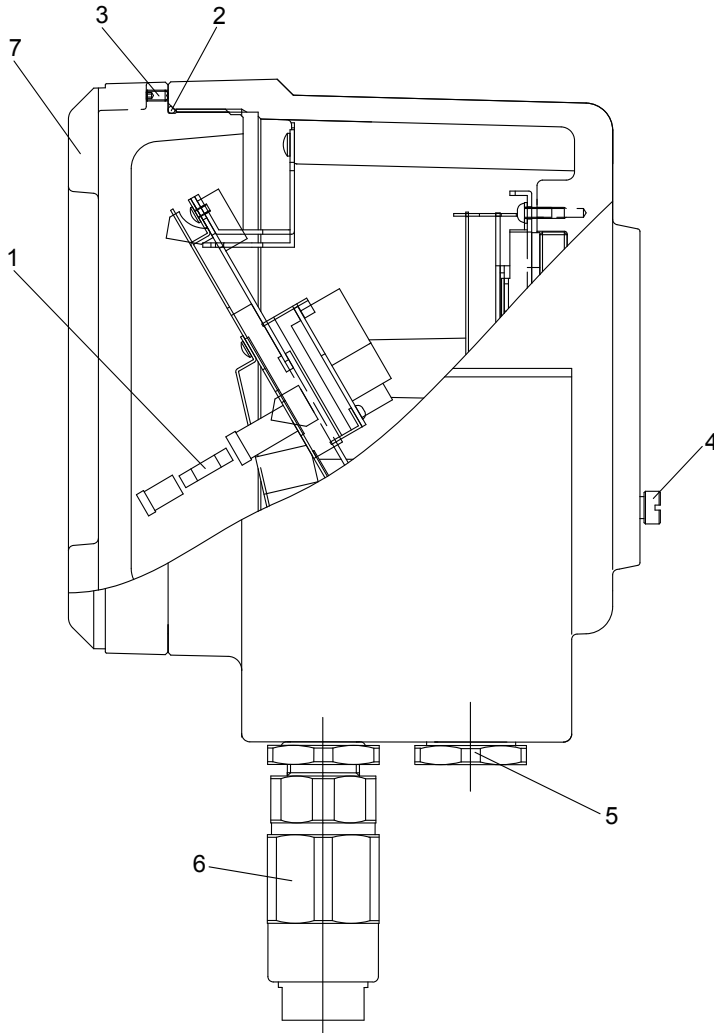

Item	Part No.	Qty	Description
1	A1109EF	1	Fuse 1.0 A (For 100 to 240 V AC)
	A1111EF	1	Fuse 2.0 A (For 24 V DC)
2	L9817MH	1	O-Ring
3	K9292XL	1	Screw
4	L9800GT	1	Screw
5	K9214GZ	3	Plug
6	L9811LL	3	Cable Gland G3/4 (PF3/4) (only GD402R)
7	K9214BF	1	Cover

Revision Information

- Title : Model GD402 Gas Density Meter
- Manual No. : IM 11T03E01-01E

Edition	Date	Remark(s)
11th	June 2017	Added RoHS compliance statement.
10th	Jan. 2017	EJA310 to EJX310A (Pages 1-2, 1-3, 1-6, 1-7, 1-8, 1-12, 2-11, 2-20) Addition of Applicable standards (Pages 1-1 and 1-2) Revised over all
9th	Feb. 2016	Addition the related documents, etc. IM number change (IM 11T3E1-01E to IM 11T03E01-01E)
8th	Jun. 2015	Style change Page i Pages 1-3, 1-6 Change of fuse type Pages 1-7, 1-8 Addition of "Style" Pages 1-7, 1-14, 2-14, 2-16 Deletion of "Surge Protector" Correction Pages i, 1-4, 1-7, 1-8, 1-12, 2-11, 2-12, 2-14, 2-16, 5-5, 5-24, 6-5, 6-24, 10-2 CMPL 11T3E1-01E 5th edition
7th	June 2012	Revised and Corrected over all
6th	Sep. 2008	All over revised
5th	Jul. 2006	Revised Section After-sales Warranty: Added description. Added Section 1.1.1.7, "Safety and EMC compliance" Deleted Section 1.4, "Safety Standard" Section 2.1.2, "GD40T (FM Explosion-proof with Intrinsically Safe Approval)": Correction error in Item 1. Section 2.4.1, Replaced the entire page. Replaced entire Section 2.4.2, "Cable Wired to Power Supply" Section 5.2.2 "Example of Entries for Concentration Measurement": Correction error of *Z_CN.D and *S_CN.D. CMPL 11T3E1-01E: Deleted Item 7, moved up the following Items, and changed part numbers of Items 5 and 9.
4th	May 2004	
1st	Sep. 1998	Newly published

-
- If you want have more information about Yokogawa products, you can visit Yokogawa's home page at the following website.
<http://www.yokogawa.com/an/>
 - Published by Yokogawa Electric Corporation
2-9-32 Nakacho, Musashino-shi, Tokyo 180-8750, JAPAN
 - Printed by KOHOKU PUBLISHING & PRINTING INC.
-

Blank Page