

GD54/74LS154

4-LINE TO 16-LINE DECODERS/DEMULTIPLEXERS

Feature

- Decodes 4 Binary-Coded Inputs into One of 16 Mutually Exclusive Outputs
- Performs the Demultiplexing Function by Distributing Data from One Input Line to Any One of 16 Outputs
- Input Clamping Diodes Simplify System Design
- High Fan-Out, Low-Impedance, Totem-Pole Outputs
- Fully Compatible with Most TTL, DTL and MSI Circuits

Description

This monolithic 4-line to 16 line decoder utilizes TTL circuitry to decode four binary-coded inputs into one of sixteen mutually exclusive outputs when both the strobe inputs, G_1 and G_2 are low. The demultiplexing function is performed by using the 4 input lines to address the output line, passing data from one of the strobe inputs with the other strobe

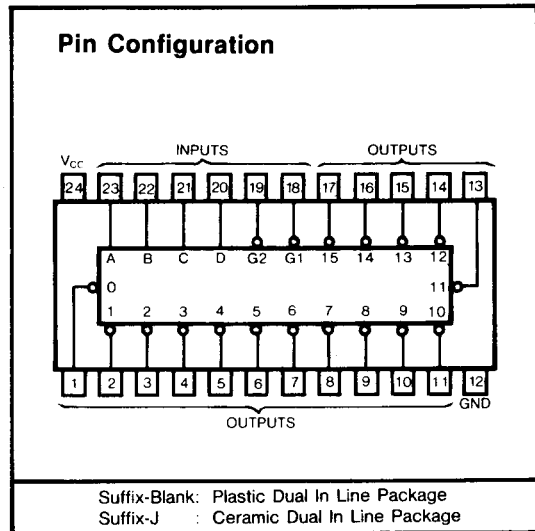

input low. When either strobe input is high, all outputs are high.

Function Table

INPUTS				OUTPUTS																		
G1	G2	D	C	B	A	0	1	2	3	4	5	6	7	8	9	10	11	12	13	14	15	
L	L	L	L	L	L	L	H	H	H	H	H	H	H	H	H	H	H	H	H	H	H	H
L	L	L	L	L	H	H	L	H	H	H	H	H	H	H	H	H	H	H	H	H	H	H
L	L	L	L	H	L	H	H	L	H	H	H	H	H	H	H	H	H	H	H	H	H	H
L	L	L	L	H	H	H	H	L	H	H	H	H	H	H	H	H	H	H	H	H	H	H
L	L	L	H	L	L	H	H	H	H	L	H	H	H	H	H	H	H	H	H	H	H	H
L	L	L	H	H	L	H	H	H	H	H	L	H	H	H	H	H	H	H	H	H	H	H
L	L	L	H	L	L	H	H	H	H	H	H	L	H	H	H	H	H	H	H	H	H	H
L	L	L	H	L	H	H	H	H	H	H	H	H	H	L	H	H	H	H	H	H	H	H
L	L	L	H	H	L	L	H	H	H	H	H	H	H	H	H	H	L	H	H	H	H	H
L	L	L	H	H	L	H	H	H	H	H	H	H	H	H	H	H	H	L	H	H	H	H
L	L	L	H	H	H	L	H	H	H	H	H	H	H	H	H	H	H	H	L	H	H	H
L	L	L	H	H	H	L	H	H	H	H	H	H	H	H	H	H	H	H	H	L	H	H
L	L	L	H	H	H	L	H	H	H	H	H	H	H	H	H	H	H	H	H	H	L	H
L	L	L	H	H	H	L	H	H	H	H	H	H	H	H	H	H	H	H	H	H	H	L
L	H	X	X	X	X	H	H	H	H	H	H	H	H	H	H	H	H	H	H	H	H	H
H	L	X	X	X	X	H	H	H	H	H	H	H	H	H	H	H	H	H	H	H	H	H
H	H	X	X	X	X	H	H	H	H	H	H	H	H	H	H	H	H	H	H	H	H	H

H: High level L: Low level X: Irrelevant

Function Block Diagram

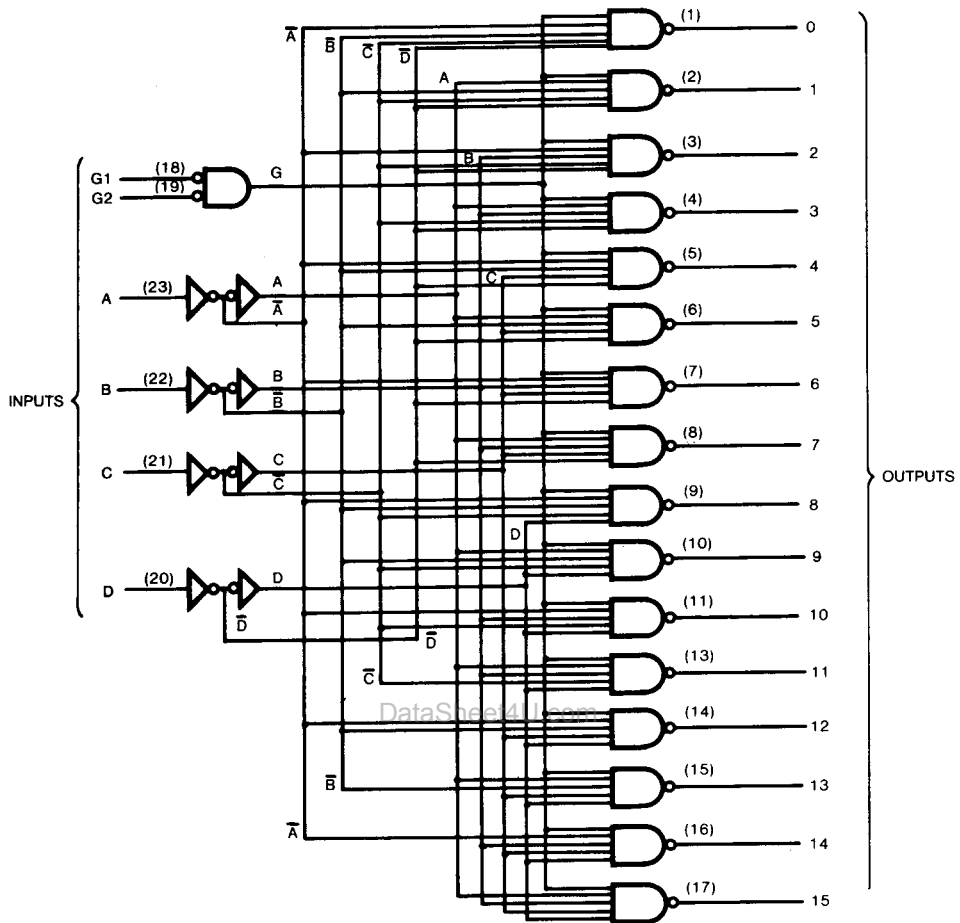

Schematics of Inputs and Outputs

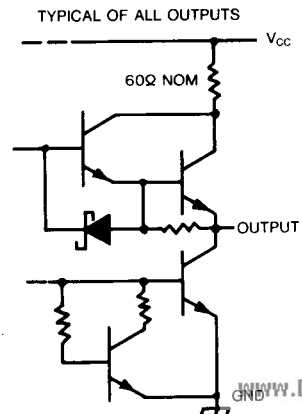
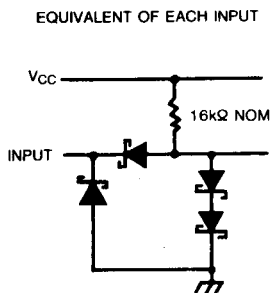

Absolute Maximum Ratings

- Supply voltage, V_{CC} 7V
- Input voltage 7V
- Operating free-air temperature range 54LS -55°C to 125°C
74LS 0°C to 70°C
- Storage temperature range -65°C to 150°C

Recommended Operating Conditions

SYMBOL	PARAMETER		MIN	NOM	MAX	UNIT
V_{CC}	Supply voltage	54	4.5	5	5.5	V
		74	4.75	5	5.25	
I_{OH}	High-level output current	54,74			-400	μA
I_{OL}	Low-level output current	54			4	mA
		74			8	
T_A	Operating free-air temperature	54	-55		125	$^{\circ}\text{C}$
		74	0		70	

Electrical Characteristics over recommended operating free-air temperature range (unless otherwise noted)

SYMBOL	PARAMETER	TEST CONDITIONS	MIN	TYP (Note 1)	MAX	UNIT	
V_{IH}	High-level input voltage			2		V	
V_{IL}	Low-level input voltage		54		0.7	V	
			74		0.8		
V_{IK}	Input clamp voltage	$V_{CC}=\text{Min}$, $I_I=-18\text{mA}$			-1.5	V	
V_{OH}	High-level output voltage	$V_{CC}=\text{Min}$ $V_{IL}=\text{Max}$	54	2.5	3.4	V	
		$I_{OH}=\text{Max}$ $V_{IH}=\text{Min}$	74	2.7	3.4		
V_{OL}	Low-level output voltage	$V_{CC}=\text{Min}$ $I_{OL}=4\text{mA}$	54,74		0.25	0.4	V
		$V_{IL}=\text{Max}$ $I_{OL}=8\text{mA}$	74		0.35	0.5	
I_I	Input current at maximum input voltage	$V_{CC}=\text{Max}$, $V_I=7\text{V}$				0.1	mA
I_{IH}	High-level input current	$V_{CC}=\text{Max}$, $V_I=2.7\text{V}$				20	μA
I_{IL}	Low-level input current	$V_{CC}=\text{Max}$, $V_I=0.4\text{V}$				-0.4	mA
I_{OS}	Short-circuit output current	$V_{CC}=\text{Max}$ (Note 2)			-20	-100	mA
I_{CC}	Supply current	$V_{CC}=\text{Max}$ (Note 3)			9	14	mA

Note 1: All typicals are at $V_{CC}=V$, $T_A=25^{\circ}\text{C}$

Note 2: Not more than one output should be shorted at a time, and the duration should not exceed one second.

Note 3: I_{CC} is measured with the inputs grounded and all outputs open.

Switching Characteristics $V_{CC}=5\text{V}$, $T_A=25^{\circ}\text{C}$

SYMBOL	TEST CONDITIONS#	MIN	TYP	MAX	UNIT
t_{PLH}	Data to output		22	36	ns
t_{PHL}	Data to output		22	33	ns
t_{PLH}	Strobe to output		18	30	ns
t_{PHL}	Strobe to output		16	27	ns

#For load circuit and voltage waveforms, see page 3-11.