 <i>Good Display</i>		SPEC NO	
	GDE029	REV NO	

Good Display Specifications

Type: Standard
Model No. GDE029

Prepared: Shouyang Zhao
Checked: Dong Wei
Approved: Jinggang Zhao



Dalian Good Display Co., Ltd.

No.17 Gonghua Street, Shahekou District, Dalian 116021 China
Tel: +86-411-84619565 Fax: +86-411-84619585
E-mail: sales@good-lcd.com.cn
Website: www.good-lcd.com

Product Specification**Revision History**

Rev.	Issued Date	Revised Contents
1.0	Jan.12.2014	Preliminary
1.1	Feb.27.2014	In part 6, Modify BUSY_N to BUSY. For more details please see page 11.
1.2	Apr.08.2014	1. Modify the specification's name GDE029

Product Specification
TECHNICAL SPECIFICATION
CONTENTS

NO.	ITEM	PAGE
-	Cover	1
-	Revision History	2
-	Contents	3
1	Over View	4
2	Features	4
3	Mechanical Specifications	4
4	Mechanical Drawing of EPD module	5
5	Input/Output Terminals	6
6	Command Table	8
7	Electrical Characteristics	14
8	Waveform LUT control software	22
9	Typical Operating Sequence	23
10	Optical Characteristics	25
11	Handling, Safety and Environment Requirements	27
12	Reliability test	28
13	Block Diagram	29
14	Point and line standard	30
15	Packing	32

Product Specification

1. Over View

The display is a TFT active matrix electrophoretic display , with interface and a reference system design.

The 2.9" active area contains 296×128 pixels, and has 1-bit full display capabilities. An integrated circuit contains gate buffer, source buffer, interface, timing control logic, oscillator, DC-DC. SRAM. LUT ,VCOM, and border are supplied with each panel.

2. Features

- High contrast
- High reflectance
- Ultra wide viewing angle
- Ultra low power consumption
- Pure reflective mode
- Bi-stable
- Commercial temperature range
- Landscape, portrait mode
- Antiglare hard-coated front-surface
- Low current deep sleep mode
- On chip display RAM
- Serial peripheral interface available
- On-chip oscillator
- On-chip booster and regulator control for generating VCOM, Gate and source driving voltage .
- I²C Signal Master Interface to read external temperature sensor
- Available in COG package IC thickness 300um

3. Mechanical Specifications

Parameter	Specifications	Unit	Remark
Screen Size	2.9	Inch	
Display Resolution	296 (H)×128 (V)	Pixel	Dpi:112
Active Area	66.9 (H)×29.1 (V)	mm	
Pixel Pitch	0.227×0.226	mm	
Pixel Configuration	Rectangle		
Outline Dimension	79.0 (H)×36.7 (V) ×1.18(D)	mm	
Weight	7.35±0.5	g	

Product Specification

4. Mechanical Drawing of EPD module

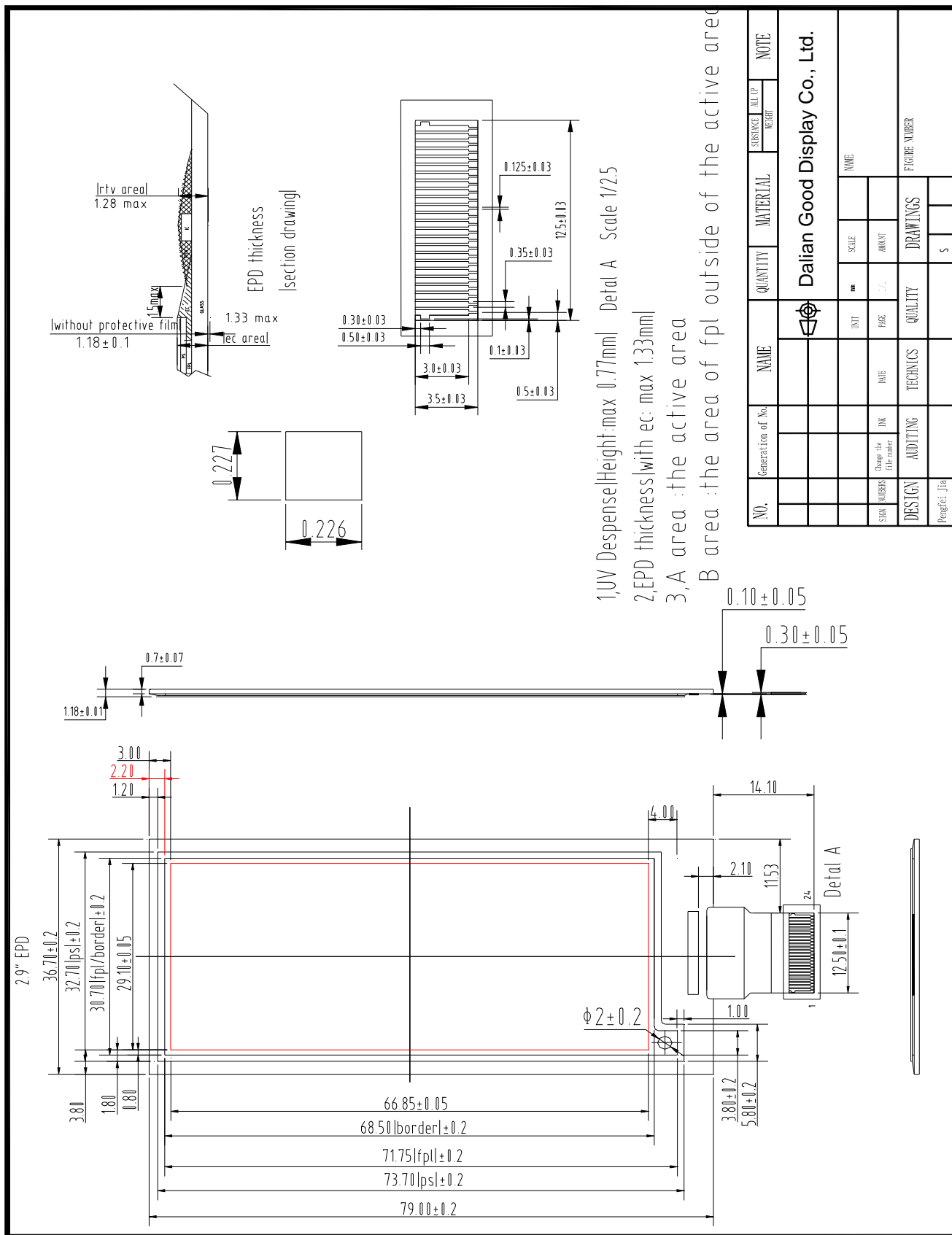

Product Specification

5. Input/Output Terminals

5-1) Pin out List

Pin #	Type	Single	Description	Remark
1		NC	No connection and do not connect with other NC pins	Keep Open
2	O	GDR	N-Channel MOSFET Gate Drive Control	
3	O	RESE	Current Sense Input for the Control Loop	
4	C	VGL	Negative Gate driving voltage	
5	C	VGH	Positive Gate driving voltage	
6	O	TSCL	I2C Interface to digital temperature sensor Clock pin	
7	I/O	TSDA	I2C Interface to digital temperature sensor Date pin	
8	I	BS1	Bus selection pin	Note 5-5
9	O	BUSY	Busy state output pin	Note 5-4
10	I	RES #	Reset	Note 5-3
11	I	D/C #	Data /Command control pin	Note 5-2
12	I	CS #	Chip Select input pin	Note 5-1
13	I/O	D0	serial clock pin (SPI)	
14	I/O	D1	serial data pin (SPI)	
15	I	VDDIO	Power for interface logic pins	
16	I	VCI	Power Supply pin for the chip	
17		VSS	Ground	
18	C	VDD	Core logic power pin	
19	C	VPP	Power Supply for OTP Programming	
20	C	VSH	Positive Source driving voltage	
21	C	PREVGH	Power Supply pin for VGH and VSH	
22	C	VSL	Negative Source driving voltage	
23	C	PREVGL	Power Supply pin for VCOM, VGL and VSL	
24	C	VCOM	VCOM driving voltage	

Note 5-1: This pin (CS#) is the chip select input connecting to the MCU. The chip is enabled for MCU communication only when CS# is pulled LOW.

Note 5-2: This pin (D/C#) is Data/Command control pin connecting to the MCU. When the pin is pulled HIGH, the data will be interpreted as data. When the pin is pulled LOW, the data will be interpreted as command.

Product Specification

Note 5-3: This pin (RES#) is reset signal input. The Reset is active low.

Note 5-4: This pin (BUSY) is Busy state output pin. When Busy is Low the operation of chip should not be interrupted and any commands should not be issued to the module. The driver IC will put Busy pin Low when the driver IC is working such as:

- Outputting display waveform; or
- Communicating with digital temperature sensor

Note 5-5: This pin (BS1) is for 3-line SPI or 4-line SPI selection. When it is “Low”, 4-line SPI is selected. When it is “High”, 3-line SPI (9 bits SPI) is selected. Please refer to below Table.

Table: Bus interface selection

BS1	MPU Interface
L	4-lines serial peripheral interface (SPI)
H	3-lines serial peripheral interface (SPI) – 9 bits SPI

Product Specification

6. Command Table

Code	Inst/Para	R/W	DC	D7	D6	D5	D4	D3	D2	D1	D0	Default
R01H	PWR	W	0	0	0	0	0	0	0	0	0	(01H)
	1 st Para	W	1	-	-	-	-	-	-	VDS_EN	V DG_EN	03H
	2 nd Para	W	1	-	-	-	-	-	-	0	0	00H
R02H	POF	W	0	0	0	0	0	0	0	1	0	(02H)
R04H	PON	W	0	0	0	0	0	0	1	0	0	(04H)
R06H	BTST	W	0	1	1	1	0	0	0	1	0	(E2H)
	1 st Para	W	1	-	0	0	BT_PHA 4	BT_PHA3	1	1	1	0FH
	2 nd Para	W	1	-	0	0	BT_PHB 4	BT_PHB3	1	1	0	0EH
	3 rd Para	W	1	-	-	-	BT_PHC 4	BT_PHC3	1	0	1	0DH
R10H	DTM1	W	0	0	0	1	0	0	0	0	0	(10H)
	1 st Para	W	KPx1[1]	KPx1[0]	KPx2[1]	KPx2[0]	KPx3[1]	KPx3[0]	KPx4[1]	KPx4[0]	KPx1[1]	00H
	W	1									00H
	M th Para	W	1	KPxI(N-1)[1]	KPxI(N-1)[0]	KPxIN[1]	KPxIN[0]					00H
R12H	DRF	W	0	0	0	0	1	0	0	1	0	(12H)

Product Specification

Cod e	Inst/P ara	R/W	DC	D7	D6	D5	D4	D3	D2	D1	D0	Defau lt
R30 H	PLL	W	0	0	0	1	1	0	0	0	0	(30H)
	1 st Para	W	0	-	-	M2	M1	M0	N2	N1	N0	3CH
R40 H	TSC	W	0	0	1	0	0	0	0	0	0	(40H)
	1 st Para	R	1	D10	D9	D8	D7	D6/TS 3	D5/TS 2	D4/TS 1	D3/TS 0	00H
	2 nd Para	R	1	D2	D1	D0	-	-	-	-	-	00H
R41 H	TSE	W	0	0	1	0	0	0	0	0	1	(41H)
	1 st Para	W	1	TSE	-	-	-	-	-	-	-	00H
R42 H	TSW	W	0	0	1	0	0	0	0	1	0	(42H)
	1 st Para	W	1	WATTR 7	WATTR6	WATTR 5	WATTR 4	WATTR 3	WATTR 2	WATTR 1	WATTR 0	00H
	2 nd Para	W	1	WMSB 7	WMSB6	WMSB5	WMSB4	WMSB3	WMSB2	WMSB1	WMSB0	00H
	3 rd Para	W	1	WLS B7	WLSB6	WLSB 5	WLSB 4	WLSB 3	WLSB 2	WLSB 1	WLSB 0	00H
R43 H	TSR	W	0	0	1	0	0	0	0	1	1	(43H)
	1 st Para	R	1	RMS B7	RMSB6	RMSB 5	RMSB 4	RMSB 3	RMSB 2	RMSB 1	RMSB 0	00H
	2 nd Para	R	1	RLSB 7	RLSB6	RLSB5	RLSB4	RLSB3	RLSB2	RLSB1	RLSB0	00H
R50 H	CDI	W	0	0	1	0	1	0	0	0	0	(50H)
	1 st Para	W	1	-	-	-	DDX	CDI3	CDI2	CDI1	CDI0	17H
R61 H	TRES	W	0	0	1	1	0	0	0	0	1	(61H)
	1 st Para	W	1	HRES 7	HRES6	HRES5	HRES4	HRES3	HRES2	HRES1	0	00H
	2 nd Para	W	1	-	-	-	-	-	-	-	HRES8	00H
	3 rd Para	W	1	VRES 7	VRES6	VRES5	VRES4	VRES3	VRES2	VRES1	VRES0	00H
R82 H	VDCS	W	0	1	0	0	0	0	0	1	0	(82H)
	1 st Para	W	1	-	-	VDCS 5	VDCS 4	VDCS 3	VDCS 2	VDCS 1	VDCS 0	00H

Product Specification

Power Setting Register

Code	Inst/Para	R/W	DC	D7	D6	D5	D4	D3	D2	D1	D0	Default
R01H	PWR	W	0	0	0	0	0	0	0	0	0	(01H)
	1 st Para	W	1	-	-	-	-	-	-	VDS_EN	V DG_EN	03H
	2 nd Para	W	1	-	-	-	-	-	-	0	0	00H

Name	Control	Value	Function Description
VDS_EN	Source Power Selection	0	External positive source voltage from VDH pin and negative source voltage from VDL pin
		1	Internal voltage generation circuit for both VDH/VDL
VDG_EN	Gate Power Selection	0	External positive source voltage from VDH pin and negative source voltage from VDL pin
		1	Internal voltage generation circuit for both VDH/VDL

Note: For this panel the 2ndPara must set as 0x00.

Power OFF

Code	Inst/Para	R/W	DC	D7	D6	D5	D4	D3	D2	D1	D0	Default
R02H	POF	W	0	0	0	0	0	0	0	1	0	(02H)

After the Power Off command, driver will power off based on the power off Sequence, BUSY will become "0". This command will turn off charge pump, T-con, source driver, gate driver, VCOM, and temperature sensor, but register data will be kept until VDD becomes OFF.

SD output and Vcom will base on previous condition. It may have 2 conditions: 0V or floating.

This command can be active only when BUSY = "1".

Power ON / Setting

Code	Inst/Para	R/W	DC	D7	D6	D5	D4	D3	D2	D1	D0	Default
R04H	PON	W	0	0	0	0	0	0	1	0	0	(04H)
R06H	BTST	W	0	1	1	1	0	0	0	1	0	(06H)
	1 st Para	W	1	-	0	0	BT_PHA4	BT_PHA3	1	1	1	0FH
	2 nd Para	W	1	-	0	0	BT_PHB4	BT_PHB3	1	1	0	0EH
	3 rd Para	W	1	-	-	-	BT_PHC4	BT_PHC3	1	0	1	0DH

Name	Control	Value	Description
BT_PHA[4:3] BT_PHB[4:3] BT_PHC[4:3]	Driving Strength	00	1
		01	2
		10	3
		11	4

NOTE: For this panel , You 'd better to set these bits's (BT_PHA \BT_PHB\BT_PHC) value to 00.

Product Specification

Data Start Transmission 1 / Data Stop Command(B/W)

Code	Inst/Para	R/W	DC	D7	D6	D5	D4	D3	D2	D1	D0	Default
R10H	DTM1	W	0	0	0	1	0	0	0	0	0	(10H)
	1 st Para	W	1	KPixel1[1:0]		KPixel2[1:0]		KPixel3[1:0]		KPixel4[1:0]		00H
		W	1		00H
	M th Para	W	1	KPixel(n-1)[1:0]		KPixel(n)[1:0]		-	-	-	-	00H

This Command starts transmitting data and write them into SRAM. To complete data transmission, command DSP(Data transmission Stop) must be issued. Then the chip will start to send data/VCOM for panel.

	KPixel(x)[1:0]	LUT
When DDX=0	00	White
	11	Black
When DDX=1	00	Black
	11	White

This command can be active only when BUSY = "1".

Data Refresh Command

Code	Inst/Para	R/W	DC	D7	D6	D5	D4	D3	D2	D1	D0	Default
R12H	DRF	W	0	0	0	0	1	0	0	1	0	(12H)

While user sent this command, driver will refresh display (data/VCOM) according to SRAM data and LUT.

This command can be active only when BUSY = "1". After display refresh command, BUSY signal will become "0".

PLL Control

Code	Inst/Para	R/W	DC	D7	D6	D5	D4	D3	D2	D1	D0	Default
R30H	PLL	W	0	0	0	1	1	0	0	0	0	(30H)
	1 st Para	W	0	-	-	M2	M1	M0	N2	N1	N0	3CH

Note: For this panel the R30H Must be set as 0x39.

Product Specification

Temperature Sensor Command

Code	Inst/Para	R/W	DC	D7	D6	D5	D4	D3	D2	D1	D0	Default
R40H	TSC	W	0	0	1	0	0	0	0	0	0	(40H)
	1 st Para	R	1	D10	D9	D8	D7	D6/TS3	D5/TS2	D4/TS1	D3/TS0	00H
	2 nd Para	R	1	D2	D1	D0	-	-	-	-	-	00H

Internal Sensor Mapping

TS[3:0]	temperature
0000	0 °C
0001	5 °C
0010	10 °C
0011	15 °C
0100	20 °C
0101	25 °C
0110	30 °C
0111	35 °C
1000	40 °C
1001	45 °C
1010	50 °C

External LM75 Sensor Mapping (D10~D0)

Table 10. Temp register value

11-bit binary (2's complement)	Hexadecimal value	Decimal value	Value
011 1111 1000	3F8	1016	+127.000 °C
011 1111 0111	3F7	1015	+126.875 °C
011 1111 0001	3F1	1009	+126.125 °C
011 1110 1000	3E8	1000	+125.000 °C
000 1100 1000	0C8	200	+25.000 °C
000 0000 0001	001	1	+0.125 °C
000 0000 0000	000	0	0.000 °C
111 1111 1111	7FF	-1	-0.125 °C
111 0011 1000	738	-200	-25.000 °C
110 0100 1001	649	-439	-54.875 °C
110 0100 1000	648	-440	-55.000 °C

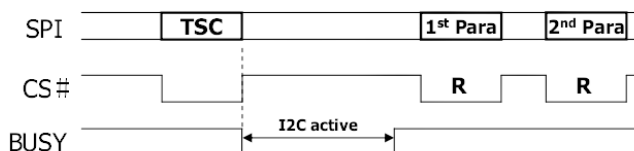

Typical External Sensor Cycles

Temperature Sensor Setting

Code	Inst/Para	R/W	DC	D7	D6	D5	D4	D3	D2	D1	D0	Default
R41H	TSE	W	0	0	1	0	0	0	0	0	1	(41H)
	1 st Para	W	1	TSE	0	0	0	0	0	0	0	00H

Name	Control	Value	Description
TSE	Temperature Sensor Selection	0	Internal temperature sensor
		1	External temperature sensor

VCOM and Data Interval Setting Command

Code	Inst/Para	R/W	DC	D7	D6	D5	D4	D3	D2	D1	D0	Default
R50H	CDI	W	0	0	1	0	1	0	0	0	0	(50 H)
	1 st Para	W	1	-	-	-	DDX	CDI3	CDI2	CDI1	CDI0	17H

Note: For this panel the R50H Must be set as 0x17.

Product Specification

Resolution Setting Command

Code	Inst/Para	R/W	DC	D7	D6	D5	D4	D3	D2	D1	D0	Default
R61H	TRES	W	0	0	1	1	0	0	0	0	1	(61H)
	1 st Para	W	1	HRES7	HRES6	HRES5	HRES4	HRES3	HRES2	HRES1	0	00H
	2 nd Para	W	1	-	-	-	-	-	-	-	HRES8	00H
	3 rd Para	W	1	VRES7	VRES6	VRES5	VRES4	VRES3	VRES2	VRES1	VRES0	00H

Name	Control	Description
HRES[7:0]	Horizontal Resolution	(1) Horizontal resolution setting (HRES[0] is forced to '0') (2) Minimum active SD channel = S0 (3) Maximum active SD channel = min_active SD + HRES[7:0] - 1
VRES[8:0]	Vertical Resolution	(1) Vertical resolution setting (2) Minimum active GD channel = G0 (3) Maximum active GD channel = min_active GD + VRES[8:0] - 1

Resolution setting(R61H) has higher priority than RES[1:0](R00H).

Note : For this panel R61H 's value must be 0x80、0x01、0x28.

VCOM-DC Setting

Code	Inst/Para	R/W	DC	D7	D6	D5	D4	D3	D2	D1	D0	Default
R82H	VDCS	W	0	1	0	0	0	0	0	0	1	(82H)
	1 st Para	W	1	-	-	VDCS5	VDCS4	VDCS3	VDCS2	VDCS1	VDCS0	0CH

VDCS[5:0]	VCOM Value	VV[5: 0]	VCOM Value
000000	0v	001101	-1.3v
000001	-0.1v	001110	-1.4v
000010	-0.2v
000011	-0.3v	100111	-3.9v
000100	-0.4v	101000	-4.0v
000101	-0.5v	101001	-4.1v
000110	-0.6v	101001	-4.2v
000111	-0.7v
001000	-0.8v	111011	-5.9v
001001	-0.9v	111100	-6.0v
001010	-1.0v	111101	-6.1v
001011	-1.1v	111110	-6.2v
001100	-1.2v	111111	-6.3v

Product Specification

7. Electrical Characteristics

7-1) Absolute maximum rating

Parameter	Symbol	Rating	Unit
Logic Supply Voltage	V _{CI}	-0.5 to +3.6	V
Logic Input Voltage	V _{IN}	-0.5 to V _{CI} +0.5	V
Logic Output Voltage	V _{OUT}	-0.5 to V _{CI} +0.5	V
Operating Temp. range	T _{OPR}	0 to +40	°C
Storage Temp. range	T _{STG}	-25 to +70	°C

7-2) Panel DC Characteristics

The following specifications apply for : V_{SS} = 0V, V_{CI} = 3.0V, T_A = 25°C

Parameter	Symbol	Conditions	Min	Typ	Max	Unit
Single ground	V _{SS}	-	-	0	-	V
Logic Supply Voltage	V _{CI}	-	2.4	3.0	3.7	V
High level input voltage	V _{IH}	-	0.8V _{CI}	-	-	V
Low level input voltage	V _{IL}	-	-	-	0.2V _{CI}	V
High level output voltage	V _{OH}	IOH= -100uA	0.9V _{CI}	-	-	V
Low level output voltage	V _{OL}	IOH= 100uA	-	-	0.1V _{CI}	V
Image update current	I _{UPDATE}	-	-	8	12	mA
Standby panel current	I _{standby}	-	-	-	5	uA
Power panel (update)	P _{MAX} P _{UPDATE}	-	-	40 26.4		mW
Standby power panel	P _{STBY}	-	-	-	0.0165	mW
Operating temperature	-	-	0	-	40	°C
Storage temperature	-	-	-25	-	70	°C
Image update Time at 25 °C	-	-	-	3000	-	ms
Deep sleep mode current	V _{CI}	DC/DC off No clock No input load Ram data not retain	-	2	5	uA
Sleep mode current	V _{CI}	DC/DC off No clock No input load Ram data retain	-	35	50	uA

- The Typical power consumption is measured with following pattern transition: from horizontal 2 gray scale pattern to vertical 2 gray scale pattern.(Note 7-1)
- The standby power is the consumed power when the panel controller is in standby mode.
- The listed electrical/optical characteristics are only guaranteed under the controller & waveform provided by WF

Product Specification

- Vcom is recommended to be set in the range of assigned value $\pm 0.1V$.

Note 7-1

The Typical power consumption

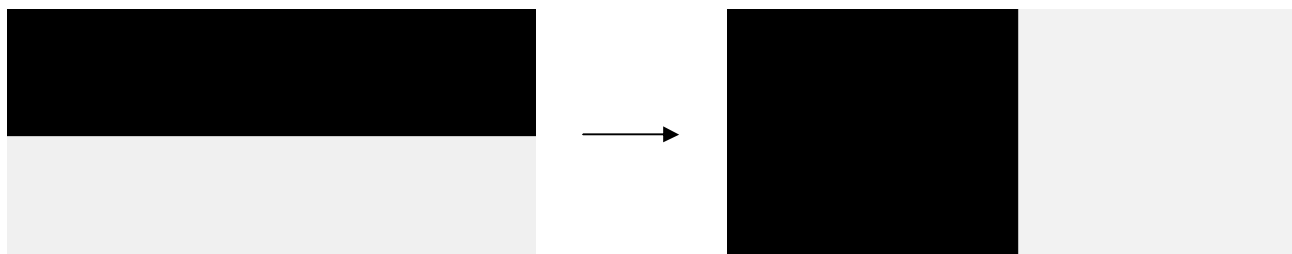

7-3) Panel AC Characteristics

7-3-1) Oscillator frequency

The following specifications apply for : VSS = 0V, VCI = 3.0V, T_A = 25°C

Parameter	Symbol	Conditions	Min	Typ	Max	Unit
Internal Oscillator frequency	Fosc	VCI=2.4 to 3.7V	0.95	1	1.05	MHz

7-3-2) MCU Interface

7-3-2-1) MCU Interface Selection

In this module, there are 4-wire SPI and 3-wire SPI that can communicate with MCU. The MCU interface mode can be set by hardware selection on BS1 pins. When it is “Low”, 4-wire SPI is selected. When it is “High”, 3-wire SPI (9 bits SPI) is selected.

Pin Name	Data/Command Interface		Control Signal		
	D1	D0	CS#	D/C#	RES#
Bus interface	SDin	SCLK	CS#	D/C#	RES#
SPI4	SDin	SCLK	CS#	L	RES#

Table 7-1: MCU interface assignment under different bus interface mode

Note 7-2: L is connected to VSS

Note 7-3: H is connected to VCI

Product Specification

7-3-2-2) MCU Serial Interface (4-wire SPI)

The 4-wire SPI consists of serial clock SCLK, serial data SDIN, D/C#, CS#. In SPI mode, D0 acts as SCLK, D1 acts as SDIN.

Function	CS#	D/C#	SCLK
Write Command	L	L	↑
Write data	L	H	↑

Table 7-2: Control pins of 4-wire Serial Peripheral interface

Note 7-9: ↑stands for rising edge of signal

SDIN is shifted into an 8-bit shift register in the order of D7, D6, ... D0. The data byte in the shift register is written to the Graphic Display Data RAM (RAM) or command register in the same clock.

Under serial mode, only write operations are allowed.

Figure 7-1: Write procedure in 4-wire Serial Peripheral Interface mode

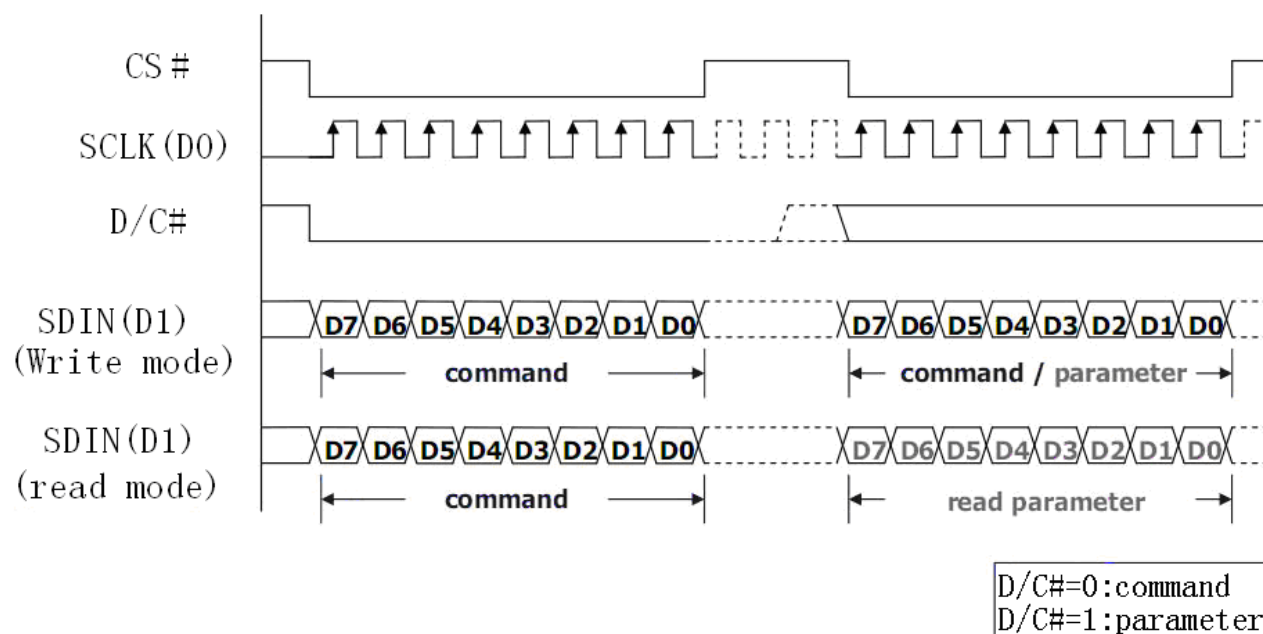

D/C# keeps the same value during the whole 8-bit cycles.

Product Specification

7-3-2-3) MCU Serial Interface (3-wire SPI)

The 3-wire serial interface consists of serial clock SCLK, serial data SDIN and CS#.

In 3-wire SPI mode, D0 acts as SCLK, D1 acts as SDIN, The pin D/C# can be connected to an external ground.

The operation is similar to 4-wire serial interface while D/C# pin is not used. There are altogether 9-bits will be shifted into the shift register on every ninth clock in sequence : D/C# bit, D7 to D0 bit. The D/C# bit (first bit of the sequential data) will determine the following data byte in shift register is written to the Display Data RAM (D/C# bit = 1) or the command register (D/C# bit = 0). Under serial mode ,only write operations are allowed.

Function	CS#	D/C#	SCLK
Write Command	L	Tie LOW	↑
Write data	L	Tie LOW	↑

Table 7-3: Control pins of 3-wire Serial Peripheral Interface

Note 7-10: ↑stands for rising edge of signal

Figure 7-2: Write procedure in 3-wire Serial Peripheral Interface mode

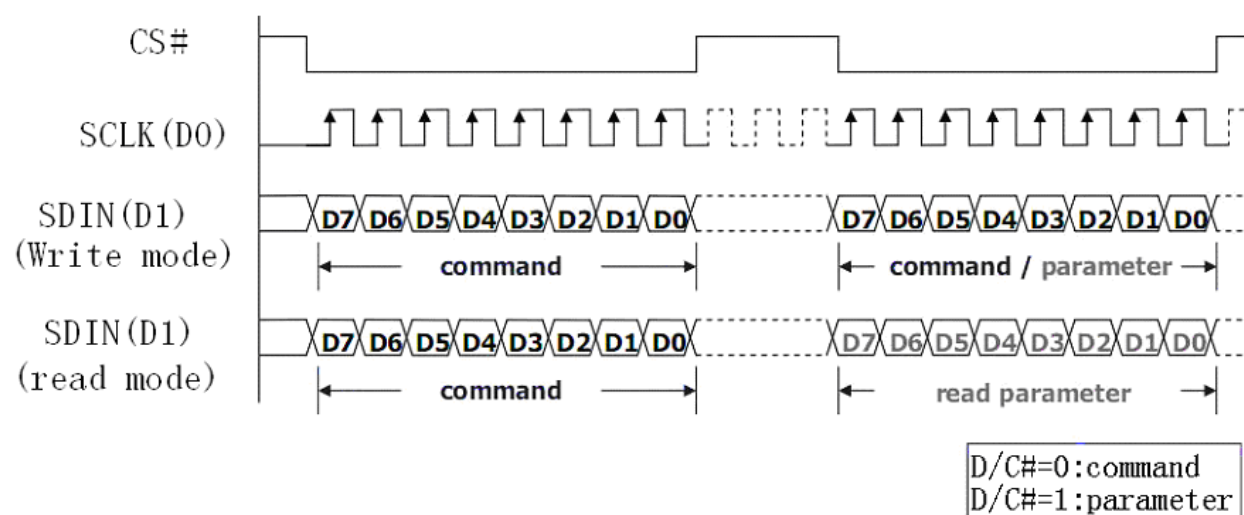

Product Specification

7-3-3) Timing Characteristics of Series Interface

Table 7-4: Serial Peripheral Interface Timing Characteristics

(VCI - VSS = 1.8 V to 2.0 v , T_A = 25°C, C_L = 20 pF)

Symbol	Parameter	Min	Typ	Max	Unit
t _{cycle}	Clock Cycle Time	250	-	-	ns
t _{AS}	Address Setup Time	150	-	-	ns
t _{AH}	Address Hold Time	150	-	-	ns
t _{CSS}	Chip Select Setup Time	120	-	-	ns
t _{CSH}	Chip Select Hold Time	60	-	-	ns
t _{DSW}	Write Data Setup Time	50	-	-	ns
t _{DHW}	Write Data Hold Time	15	-	-	ns
t _{CLKL}	Clock Low Time	100	-	-	ns
t _{CLKH}	Clock High Time	100	-	-	ns
t _R	Rise Time [20%~80%]	-	-	15	ns
t _F	Fall Time [20%~80%]	-	-	15	ns

Figure 7-3 : Serial peripheral interface characteristics

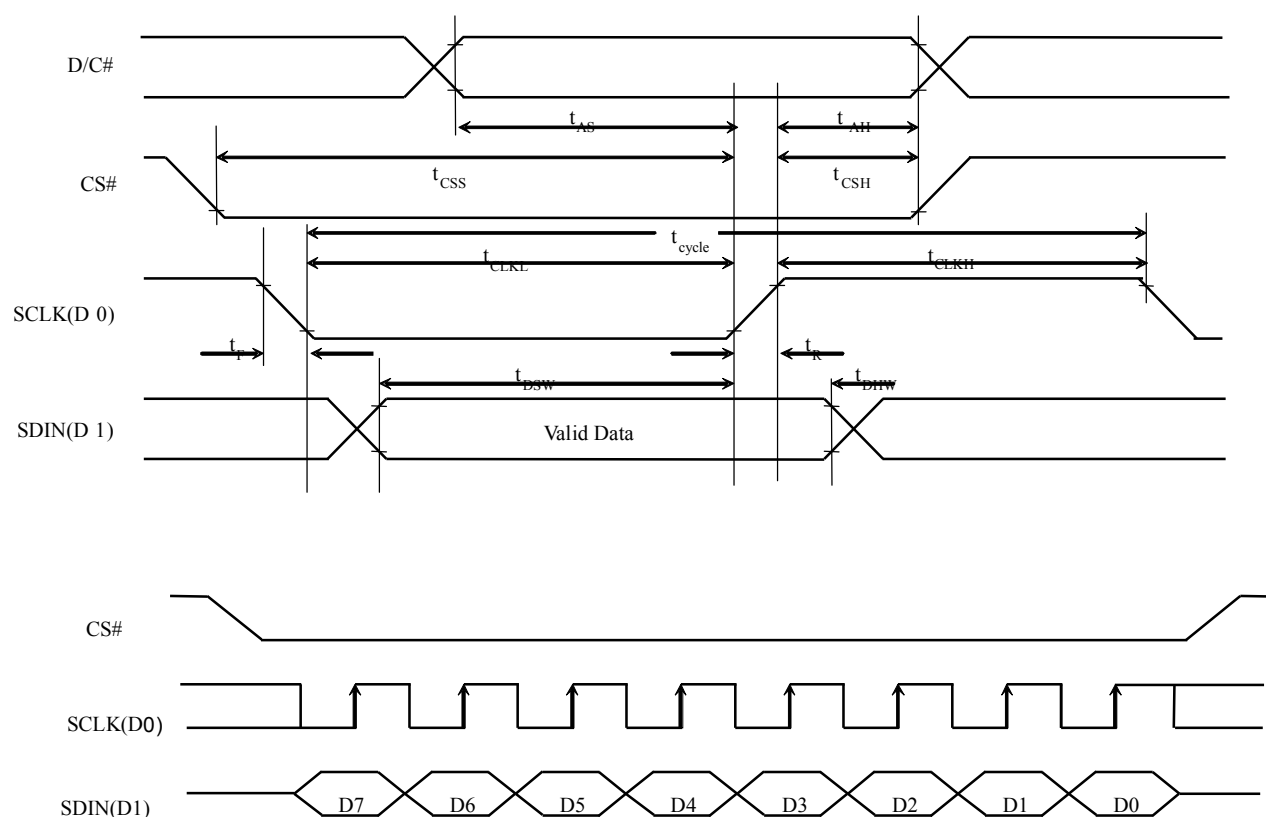

Product Specification

7-4) Power Consumption

Parameter	Symbol	Conditions	TYP	Max	Unit	Remark
Panel power consumption during update	-	-	30	40	mW	-
Power consumption in standby mode	-	-	-	0.017	mW	-

7-5) Reference Circuit

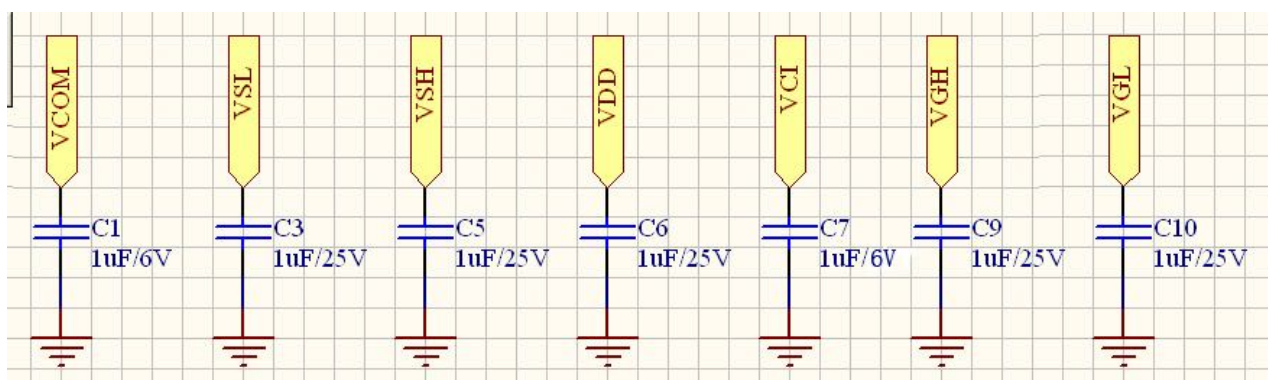
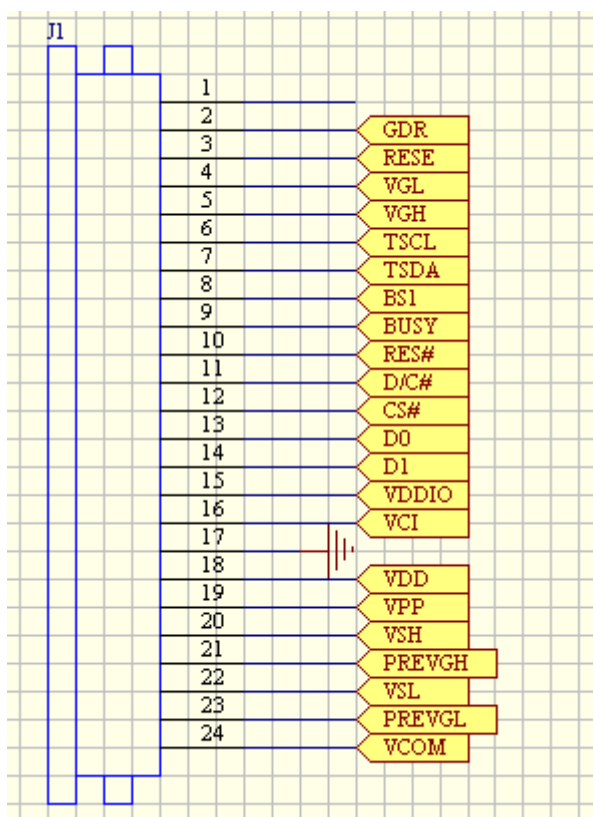

Figure . 7-5 (2)

Product Specification

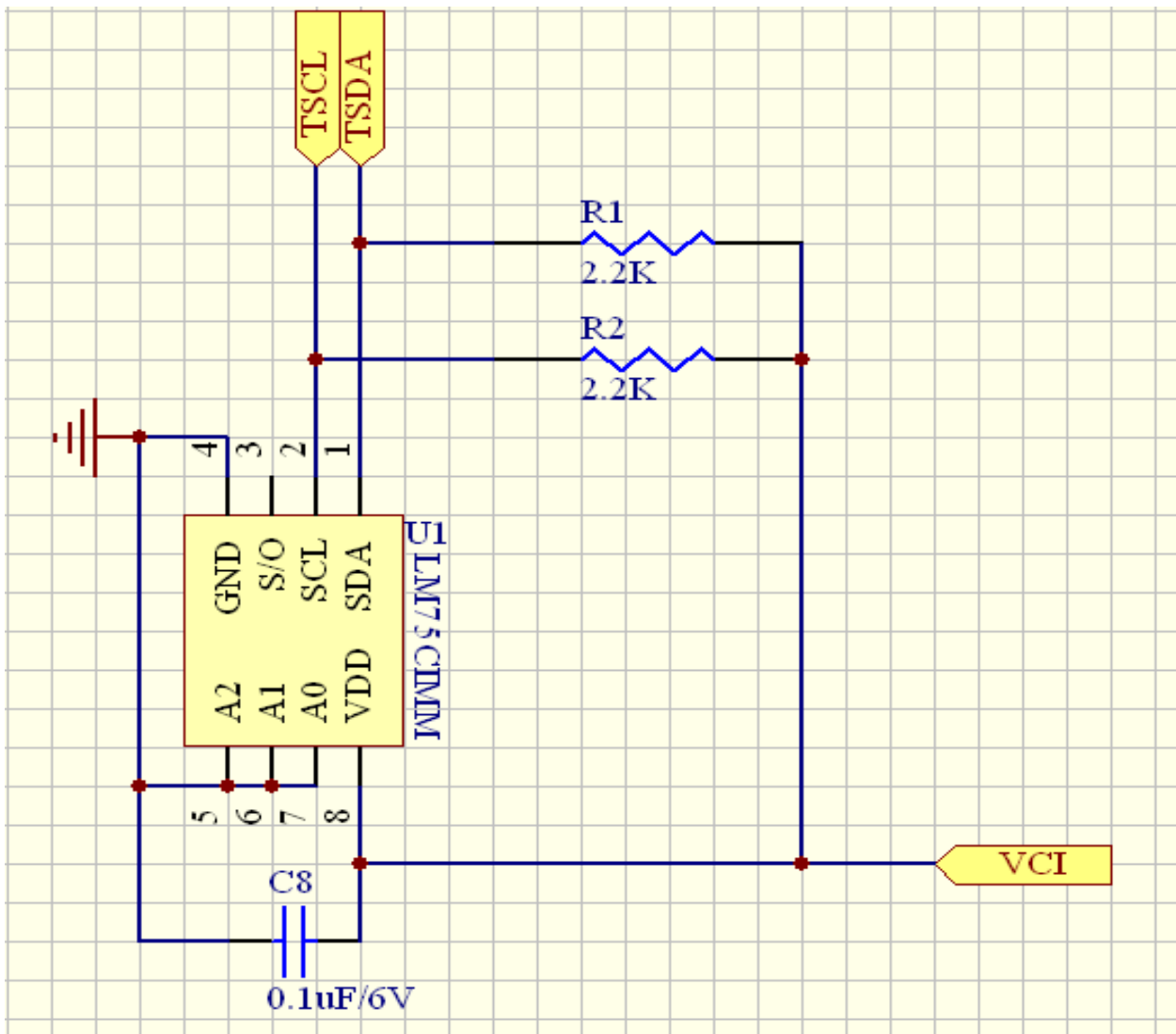

Figure . 7-5 (3)

Product Specification

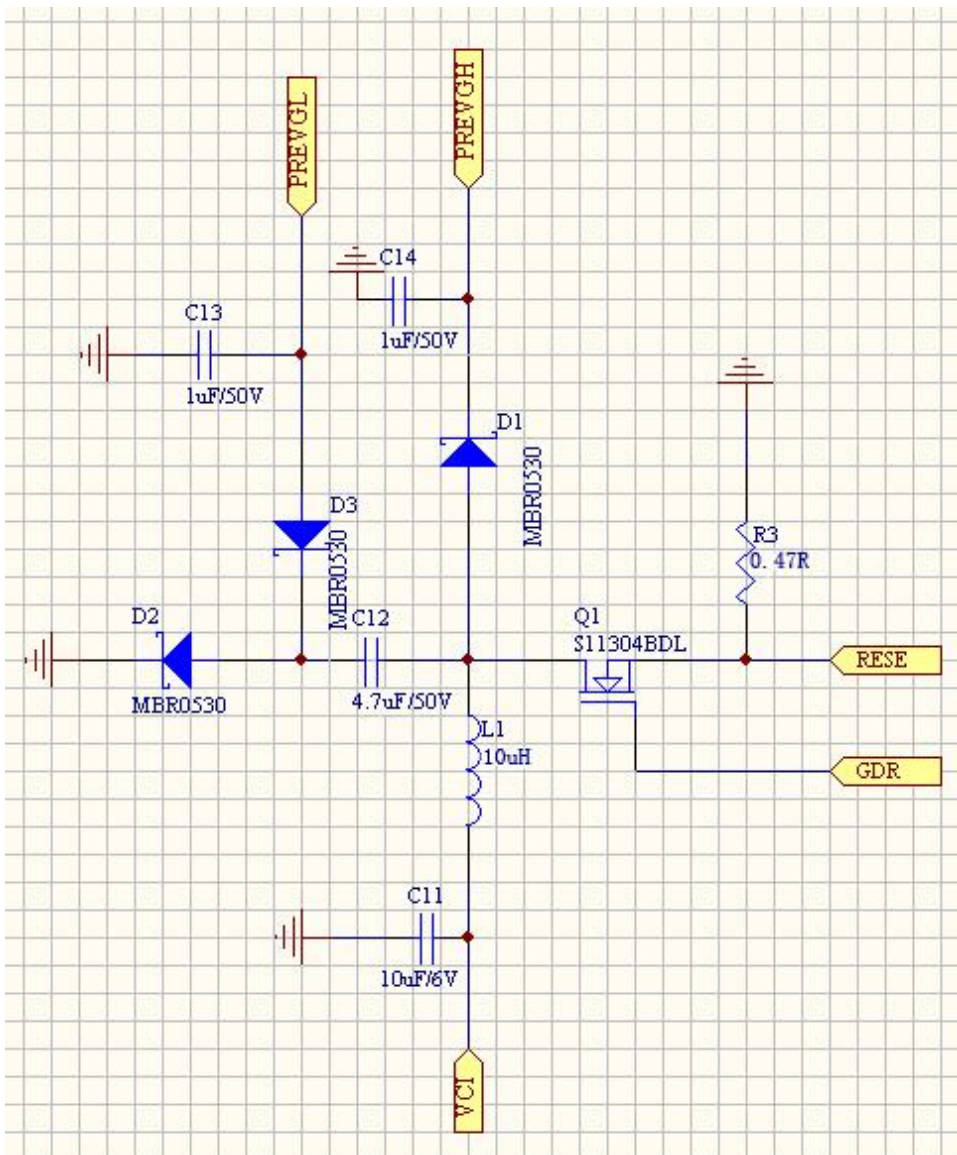

Figure . 7-5 (4)

Product Specification

8. Waveform LUT control software

For every bunch of EPD the waveform data is different, so you may receive the waveform LUT from WF. You just need to use the follow sequence to download the waveform into driver IC.

sequence	command	Action Description	remark
1	04	Power on	Send cmd 04
2	20	VCOM LUT Setting	Send cmd 20 data lut_vcom0[]
3	21	White LUT Setting	Send cmd 21 data lut_w[]
4	22	Black LUT Setting	Send cmd 22 data lut_b[]

Note: To download the waveform into driver ic ,you must send command 04 first, then send 20,21,22command .

The data of lut_vcom0[], lut_w[], lut_b[],each batch of EPD is different. WF will support the data after you receive the EPD.

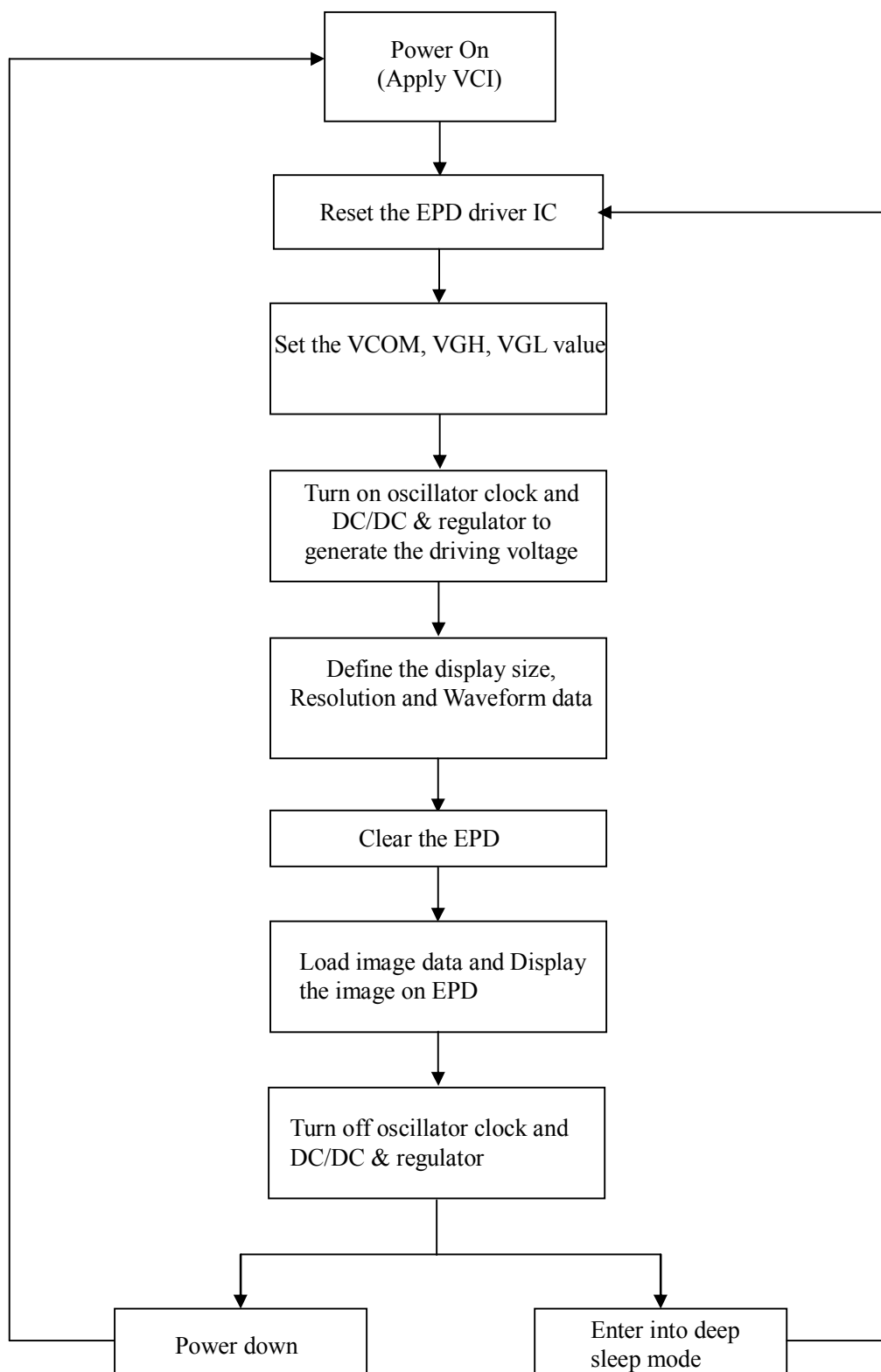
Product Specification**9. Typical Operating Sequence****9.1) Normal Operation Flow**

9.2) Reference Program Code

TBD

Product Specification

10. Optical characteristics

10-1) Specifications

Measurements are made with that the illumination is under an angle of 45 degrees, the detection is perpendicular unless otherwise specified.

T=25°C

SYMBOL	PARAMETER	CONDITIONS	MIN	TYPE	MAX	UNIT	Note
R	Reflectance	White	30	35	-	%	Note 10-1
Gn	2Grey Level	-	-	$DS+(WS-DS) \times n^{(m-1)}$	-	L*	-
CR	Contrast Ratio	indoor	8		-	-	-
T _{update}	Update time		-	3	-	sec	-
Panel's life		0°C~40°C		1000000 times or 5 years			Note 10-2

WS : White state, DS : Dark state

Gray state from Dark to White : DS、WS

m : 2

Note 10-1 : Luminance meter : Eye – One Pro Spectrophotometer

Note 10-2 :When work in temperature below 0 degree or above 40 degree , we do not recommend because the panel's life will not be guaranteed

10-2) Definition of contrast ratio

The contrast ratio (CR) is the ratio between the reflectance in a full white area (R1) and the reflectance in a dark area (Rd)() :

R1: white reflectance Rd: dark reflectance

$$CR = R1/Rd$$

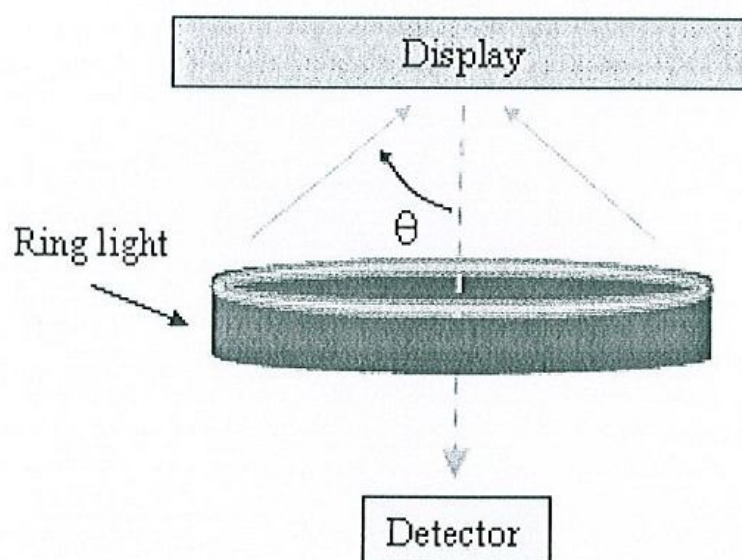

Product Specification

10-3) Reflection Ratio

The reflection ratio is expressed as :

$$R = \text{Reflectance Factor}_{\text{white board}} \times (L_{\text{center}} / L_{\text{white board}})$$

L_{center} is the luminance measured at center in a white area ($R=G=B=1$) . $L_{\text{white board}}$ is the luminance of a standard white board . Both are measured with equivalent illumination source . The viewing angle shall be no more than 2 degrees .

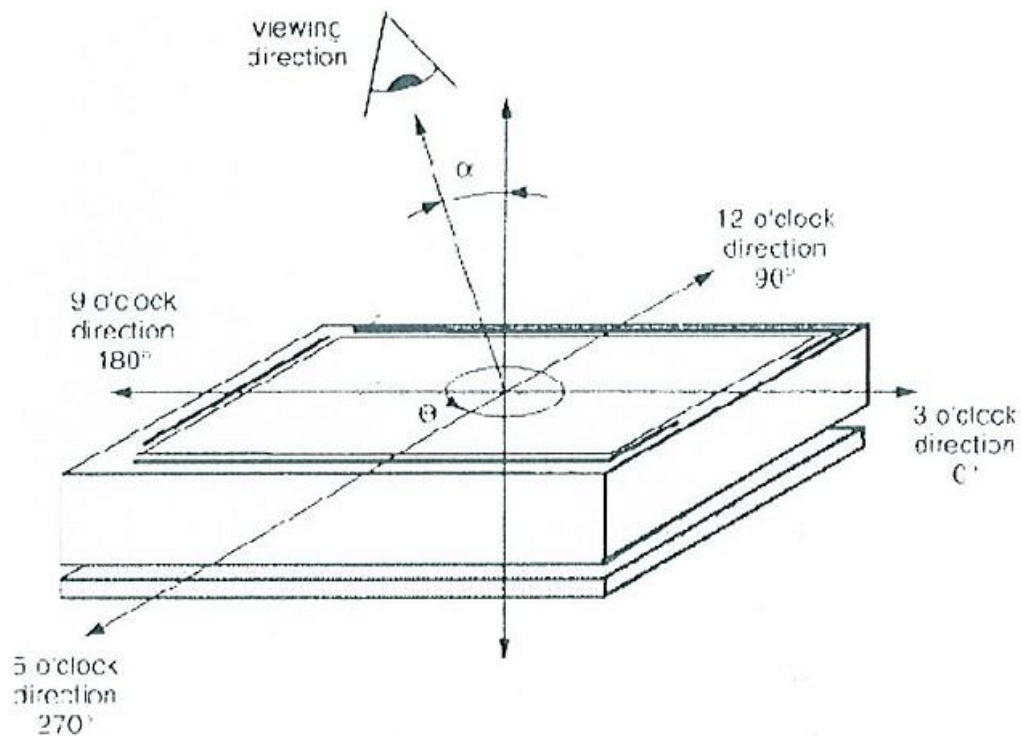

10-4) Bi-stability

The Bi-stability standard as follows:

Bi-stability	Result		
		AVG	MAX
24 hours Luminance drift	White state ΔL^*	-	3
	Black state ΔL^*	-	3

Product Specification

11. HANDLING, SAFETY AND ENVIROMENTAL REQUIREMENTS

WARNING

The display glass may break when it is dropped or bumped on a hard surface . Handle with care.
Should the display break, do not touch the electrophoretic material . In case of contact with electrophoretic material , wash with water and soap.

CAUTION

The display module should not be exposed to harmful gases , such as acid and alkali gases , which corrode electronic components.

Disassembling the display module can cause permanent damage and invalidate the warranty agreements.

Observe general precautions that are common to handling delicate electronic components . The glass can break and front surfaces can easily be damaged . Moreover the display is sensitive to static electricity and other rough environmental conditions.

Data sheet status

Product specification	The data sheet contains final product specifications.
-----------------------	---

Limiting values

Limiting values given are in accordance with the Absolute Maximum Rating System (IEC 134).

Stress above one or more of the limiting values may cause permanent damage to the device.

These are stress ratings only and operation of the device at these or any other conditions above those given in the Characteristics sections of the specification is not implied . Exposure to limiting values for extended periods may affect device reliability.

Application information

Where application information is given , it is advisory and dose not form part of the specification.

Product Environmental certification

ROHS

Product Specification

12. Reliability test

	TEST	CONDITION	METHOD	REMARK
1	High-Temperature Operation	T = 40°C, 30% for 240 hrs	IEC 60 068-2-2Bp	
2	Low-Temperature Operation	T = 0°C for 240 hrs	IEC 60 068-2-2Ab	
3	High-Temperature Storage	T = +70°C, 23% for 240 hrs Test in white pattern	IEC 60 068-2-2Bp	
4	Low-Temperature Storage	T = -25°C for 240 hrs Test in white pattern	IEC 60 068-2-2Ab	
5	High Temperature, High-Humidity Operation	T=+40°C, RH=90% for 240hrs	IEC 60 068-2-3CA	
6	High Temperature, High-Humidity Storage	T=+60°C, RH=80% for 240hrs Test in white pattern	IEC 60 068-2-3CA	
7	Temperature Cycle	[-25°C 30mins]→ [+70°C 30mins] , 70cycles Test in white pattern	IEC 60 068-2-14NB	
8	UV exposure Resistance	765 W/m ² for 168 hrs, 40°C	IEC 60 068-2-5 Sa	
9	Electrostatic discharge	Air-mode: +/-8kV, Contact-mode: +/-6kV, 330 Ω, 150pF	IEC61000-4-2	
10	Package Vibration	1.04G, Frequency : 10~500Hz Direction : X, Y, Z Duration: 1 hours in each direction	Full packed for shipment	
11	Package Drop Impact	Drop from height of 122 cm on Concrete surface Drop sequence: 1 corner, 3 edges, 6 face One drop for each.	Full packed for shipment	

Actual EMC level to be measured on customer application.

Note : The protective film must be removed before temperature test.

13. Block Diagram

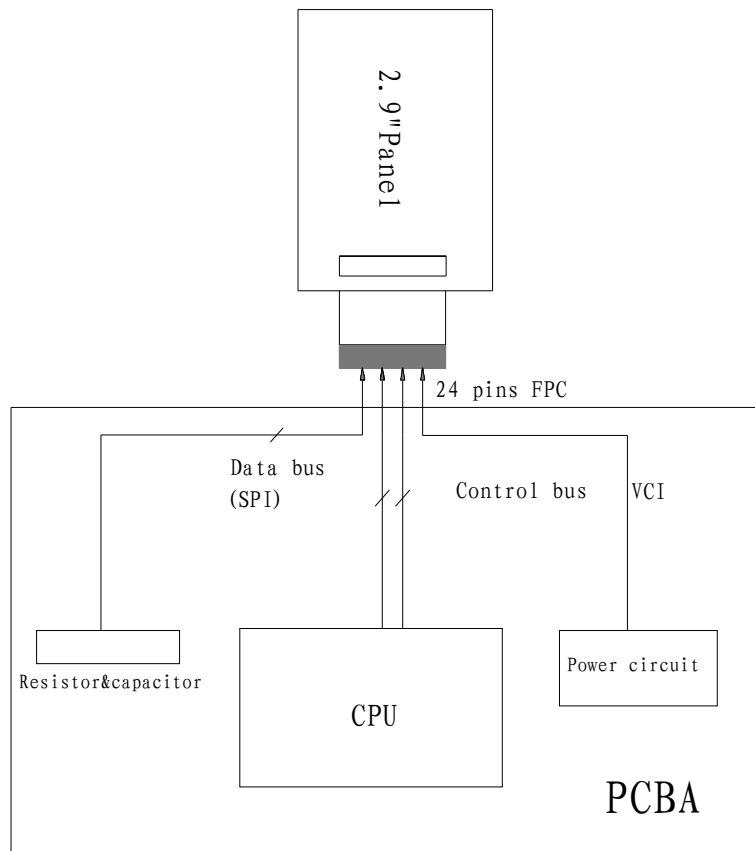

Product Specification

14. Point and line standard

Shipment Inseption Standard

Equipment: Electrical test fixture, Point gauge

Outline demension:

79.0 (H)×36.7 (V) ×1.18(D)

Unit: mm

Environment	Temperature	Humidity	Illumina nce	Distance	Time	Angle
	20℃~25℃	40%~55%RH	800~ 1200Lux	200~300 mm	35Sec	
appearance standard	Defet type	Inspection	Standard		Part-A	
	1. Spot (non-sw itching) (point overproof)	Electric Display	D≤0.25 mm		Ignore	
			0.25 mm < D ≤ 0.4 mm		N ≤ 2	>20mm from any other defect
			0.4 mm < D		0	
	2. Line (No switch)	L ≤ 0.24	OR	W ≤ 0.06	Ignore	
		0.24 < L ≤ 0.4	And	0.06 < W ≤ 0.1	N ≤ 2	>20mm from any other defect
		L > 0.4	OR	W > 0.1	0	
	3. line (Switching line)	Electric Display	Ignore in gray scale viewing In Blak&white viewing Follow Non-Switching Criteria			
	4. Display unwork	Electric Display	Not Allow			
	5. Display error	Electric Display	Not Allow			
	6. PS PET warping	Vsual	cannot beyond 1/2 of the border			
7. Protector hurt	Vsual	L ≤ 2 mm, W ≤ 0.05 mm, Ignore;				
		L > 2 mm, W > 0.05 mm, Not Allow;				
8. Adhesive coating	Vsual	Bubble: D ≤ 0.65 & N ≤ 2				
9. Packing	Vsual	cannot be dirty and breakdown; must be marked and identified				
Remark	1. Cannot be defect&failure cause by appearance defect;					
	2. Cannot be larger size cause by appearance defect;					

Product Specification

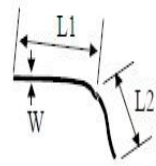

$$L = L1 + L2$$

Line Defect

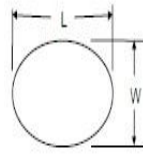

$$D = (L + W) / 2$$

Spot Defect

L=long W=wide D=point size

Edition	Content	Date
1	New edition	Sep. 30. 2013

Product Specification

15. Packing

