



website <http://biz.LGService.com>  
e-mail <http://www.LGService.com/techsup.html>

# DVD-ROM DRIVE SERVICE MANUAL

**MODEL: GDR-8162B**



**MODEL : GDR-8162B**

# TABLE OF CONTENTS

<b>INTRODUCTION</b> .....	<b>3</b>
<b>GENERAL FEATURES</b> .....	<b>3</b>
<b>SPECIFICATIONS</b> .....	<b>4</b>
<b>LOCATION OF CUSTOMER CONTROLS</b> .....	<b>5</b>
<b>DISASSEMBLY</b> .....	<b>6</b>
1. CABINET and CIRCUIT BOARD DISASSEMBLY .....	6
1-1. Bottom Chassis.....	6
1-2. Front Bezel Assy.....	6
1-3. Cabinet and Main Circuit Board.....	6
2. MECHANISM ASSY.....	6
2-1. Base Pick-up Unit Assy .....	6
<b>EXPLODED VIEW</b> .....	<b>7~8</b>
<b>MECHANICAL REPLACEMENT PARTS LIST</b> .....	<b>9~12</b>
<b>INTERNAL STRUCTURE OF THE PICK-UP</b> .....	<b>13~17</b>
1. Structure of the Pick-Up .....	13
2. Structure of the Photo Diode (CD) .....	15
3. Structure of the Photo Diode (DVD-ROM) .....	16
4. Structure of the Photo Diode (DVD-RAM).....	17
<b>DESCRIPTION OF CIRCUIT</b> .....	<b>18~29</b>
1. ALPC (Automatic Laser Power Control).....	18
2. RF Amplifier Circuit .....	19
3. Servo Signal.....	20
4. About DVD-RAM 2.6G, 4.7G Signal .....	28
<b>DESCRIPTION OF DATA PROCESSING</b> .....	<b>30~33</b>
1. Data Processing Flow .....	30
2. Copy Protection and Regional Code Management Block.....	31
3. About Prevention the DVD-ROM from to be copy.....	32
4. About the DVD-ROM Regional Code.....	33
<b>MAJOR IC INTERNAL BLOCK DIAGRAM AND PIN DESCRIPTION</b> .....	<b>34~43</b>
<b>TROUBLESHOOTING GUIDE</b> .....	<b>44~59</b>
<b>BLOCK DIAGRAM</b> .....	<b>60</b>
<b>CIRCUIT DIAGRAM</b> .....	<b>61~63</b>
<b>PRINTED CIRCUIT BOARD DIAGRAM</b> .....	<b>64~67</b>
<b>ELECTRICAL REPLACEMENT PARTS LIST</b> .....	<b>68~79</b>

**CLASS 1 LASER PRODUCT**

**CAUTION - VISIBLE AND INVISIBLE LASER RADIATION WHEN OPEN.  
DO NOT STARE INTO BEAM OR VIEW DIRECTLY WITH OPTICAL INSTRUMENTS.**

# INTRODUCTION

This service manual provides a variety of service information. It contains the mechanical structure of the DVD-ROM Drive together with mechanical adjustments and the electronic circuits in schematic

form. This DVD-ROM Drive was manufactured and assembled under our strict quality control standards and meets or exceeds industry specifications and standards.

## GENERAL FEATURES

- 5.25" Half-height size built-in type DVD-ROM Drive
- Enhanced IDE (ATAPI) bus interface (SFF-8090v3 rev.1.00 and SFF-8020i rev.2.6) Standard 2.54mm pitch bus connector for non-shielded type cable
- Ultra DMA 33 support
- Authentication function support
- 16 mode output for CD audio
- Software Volume Control via ATAPI Mode Select Command
- PC99 compatible
- Tray type loading with emergency eject
- Low self vibration and low acoustic noise
- Dust-free chassis
- Installation posture : Horizontal / Vertical
- MTBF : 125,000 POH
- **<DVD-ROM>**
  - 1) Single layered disc : 6.7 to 16X max. Full CAV, data transfer : 22.1 Mbytes/s max.  
Dual layered disc : 5 to 12X max. Full CAV, data transfer : 16.6 Mbytes/s max.  
Video disc (w/CSS) : 3.3 to 8X max. Full CAV, data transfer : 11.1 Mbytes/s max.
  - 2) High speed access : Random access time 120ms typical (Single layered disc)
  - 3) Read compatible for both 4.7Gbytes/side and 3.9Gbytes/side DVD-R disc.
  - 4) Read compatible for DVD-RW (Ver.1.0 & 1.1)/DVD+RW disc
- **<CD-ROM>**
  - 1) 21 to 48X max. Full CAV, data transfer : 7.2 Mbytes/s max.
  - 2) High speed access : Random access time 100ms typical
  - 3) CD-R, CD-RW, CD Extra, CD TEXT disc read compatible
  - 4) Addressing Methode 2 for fixed length Packet supported (CD-R Orange Book Part2)
  - 5) CD-DA (Digital Audio) data output through the IDE bus
  - 6) Embedded error correction EDC & ECC for Mode 1 & Mode 2 Form 1
  - 7) MPC 3 compatible
  - 8) Max. 40X D.A.E. Speed (Correspond to Max. 48X Write CD-R/RW drive)
- **<DVD-RAM>**
  - 1) Read compatible for both 4.7Gbytes/side and 2.6Gbytes/side DVD-RAM disc
  - 2) 2.6Gbytes/side DVD-RAM 2X speed ZCLV : 2,770Mbytes/s typ.
  - 3) 4.7Gbytes/side DVD-RAM 2X speed ZCLV : 2,770Mbytes/s typ.
  - 4) High speed access : 210 ms typical (1/3 stroke)

# SPECIFICATIONS

## 1. SUPPORTED SYSTEM

- IBM Compatible Pentium 133MHz or Above (with PIO mode 4, TX chip set recommended)

## 2. SUPPORTED OS

- MS-DOS (Ver 3.1 or Higher)
- Windows 3.1/95/98/2000/ME/XP
- Windows NT (Ver 4.0)
- OS/2 Warp (Ver 3.0)
- Solaris (Ver 2.4 or Higher)
- Linux '96 Slacware (Ver 3.1.0)

## 3. GENERAL PERFORMANCE

- Data Transfer Rate ..... Sustained Data Transfer Rate
 

DVD-ROM	Single Layered	:	22.1 Mbytes/s max.
	Dual Layered	:	16.6 Mbytes/s max.
	Video(w/CSS)	:	11.1 Mbytes/s max.
	DVD-R 3.9GB/4.7GB	:	8.29 Mbytes/s max.
	DVD-RW/+RW	:	8.29 Mbytes/s max.
	DVD-RAM 2.6GB/4.7GB	:	2.77 Mbytes/s typ.
CD-ROM	Mode1	:	7.2 Mbytes/s max.
	CD-R (Mode1)	:	6.0 Mbytes/s max.
	CD-RW(Mode1)	:	6.0 Mbytes/s max.
	CD-DA(D.A.E)	:	6.0 Mbytes/s max.
	CD-DA(Audio)	:	1.2 Mbytes/s max.
- Data Buffer Capacity ..... 256 kbytes
- Access Time ..... Random Access
 

DVD	: 120ms Typical (16X)
CD	: 100ms Typical (48X)

## 4. POWER REQUIREMENTS

- Voltage ..... +5V DC  $\pm 5\%$   
+12V DC  $\pm 10\%$
- Ripple ..... +5V : 120mVp-p  
+12V : 120mVp-p
- Current ..... +12V : 900mA (Average), 1.35A (Maximum)  
+5V : 600mA (Average), 0.9A (Maximum)

## 5. AUDIO PERFORMANCE

- Frequency Response ..... 20Hz~20KHz( $\pm 3$ dB)
- S/N Ratio (IHF-A+20kHz LPF) ..... 75 dB (Typical at 1 KHz 0dB)  
70 dB (Limit at 1 KHz 0dB)
- T.H.D. (IHF-A+20kHz LPF) ..... 0.05% (Typical at 1 KHz 0dB)  
0.15% (Limit at 1 KHz 0dB)
- Channel Separation (IHF-A+20kHz LPF) ..... 75 dB(Typical)  
70 dB(Limit)
- Output Voltage (1kHz 0dB) 47K $\Omega$  Load ..... 0.70Vrms  $\pm 20\%$

# LOCATION OF CUSTOMER CONTROLS

## FRONT VIEW

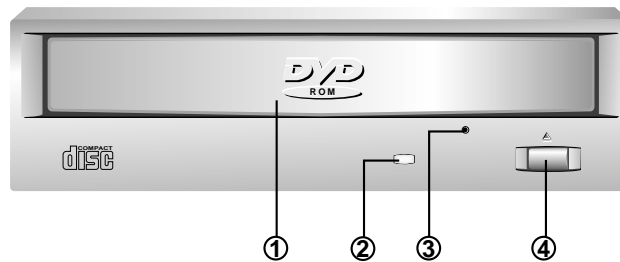

**(1) Disc Drawer**

Accepts a CD-ROM/DVD-ROM disc on its tray.

**(2) Busy Indicator**

The Busy Indicator lights during initialization and data-read operations.

**(3) Emergency Eject Hole**

Insert a paper clip here to eject the drawer manually or when there is no power.

**(4) Open/Close/Stop Button**

This button is pressed to open or close the CD tray. If an audio CD is playing, pressing this button will stop it, and pressing it again will open the tray.

## BACK VIEW

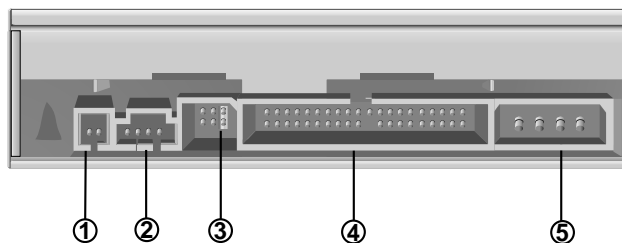

**(1) Digital Audio Output Connector**

This connector is not supported.

**(2) Analog Audio Output Connector**

The Audio Output Connector connects to a sound card.

**(3) Master/Slave/CSEL Jumper**

These three jumpers are used to set the DVD-ROM Drive to either a Master, Slave, or CSEL device.

**(4) Interface Connector**

This 40-pin connector is used to transfer data and control signals between the DVD-ROM Drive and your PC.

**(5) Power-in Connector**

Attach a power cable from the computer to this connector.

# DISASSEMBLY

## 1. CABINET and CIRCUIT BOARD DISASSEMBLY

### 1-1. Bottom Chassis

- A. Release 4 screws (A) and remove the Bottom Chassis in the direction of arrow (1). (See Fig. 1-1)

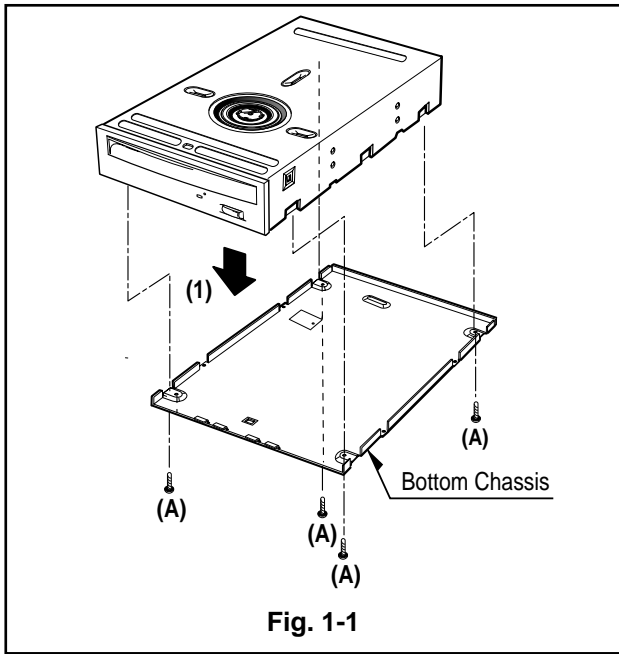

### 1-2. Front Bezel Assy

- A. Insert and Press a rod in the Emergency Eject Hole and then the CD Tray will open in the direction of arrow (2).
- B. Remove the Tray Door in the direction of arrow (3) by pushing it outward.
- C. Release 3 stoppers and remove the Front Bezel Assy.

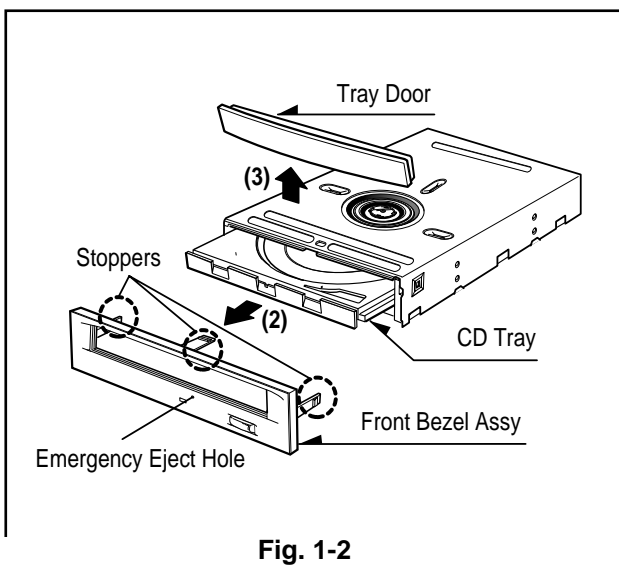

### 1-3. Cabinet and Main Circuit Board

- A. Remove the Cabinet in the direction of arrow (4). (See Fig. 1-3)
- B. Release 2 hooks (a) and remove the CD Tray.
- C. Remove the Soldering of the LD- and LD+ (B) for the Loading Motor, and then remove the Main Circuit Board.
- D. At this time, be careful not to damage the 3 connectors of the Main Circuit Board.

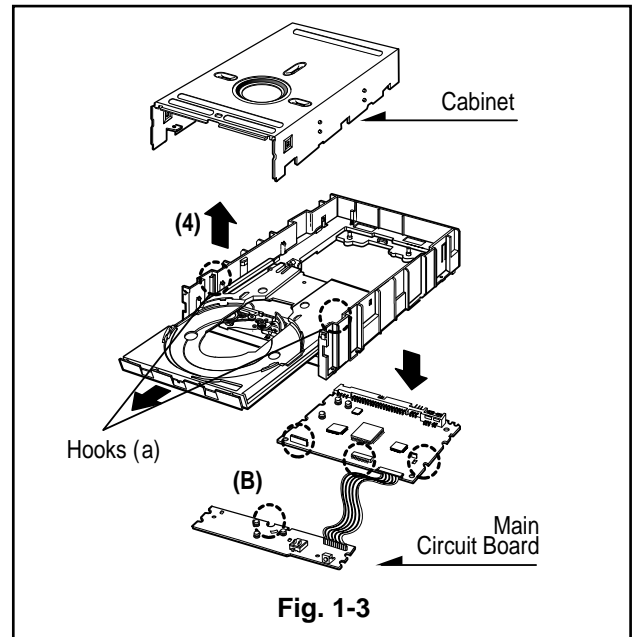

## 2. MECHANISM ASSY

### 2-1. Base Pick-Up Unit Assy

- A. Separate the Base Pick-Up Unit Assy from the Mechanism Assy.
- B. Release 2 screws (C) and 1 hook and then remove the Base Pick-Up Unit Assy.

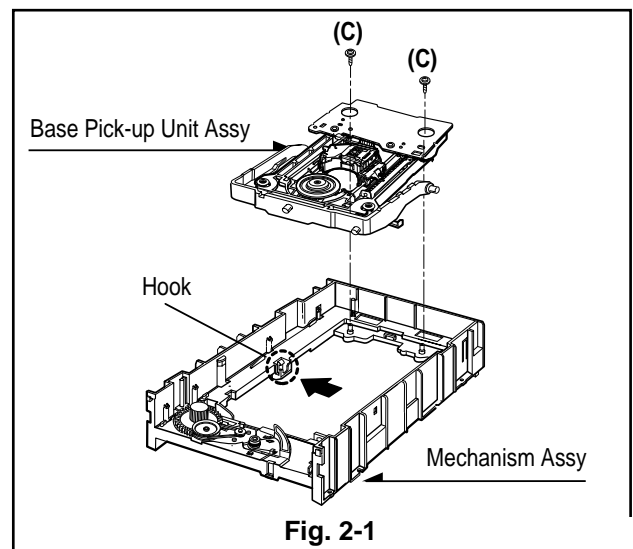

# EXPLODED VIEW

5

4

3

2

1

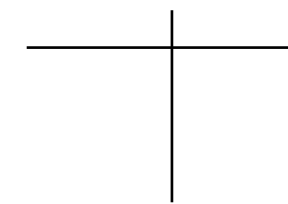

PBM00 (MAIN C.B.A)

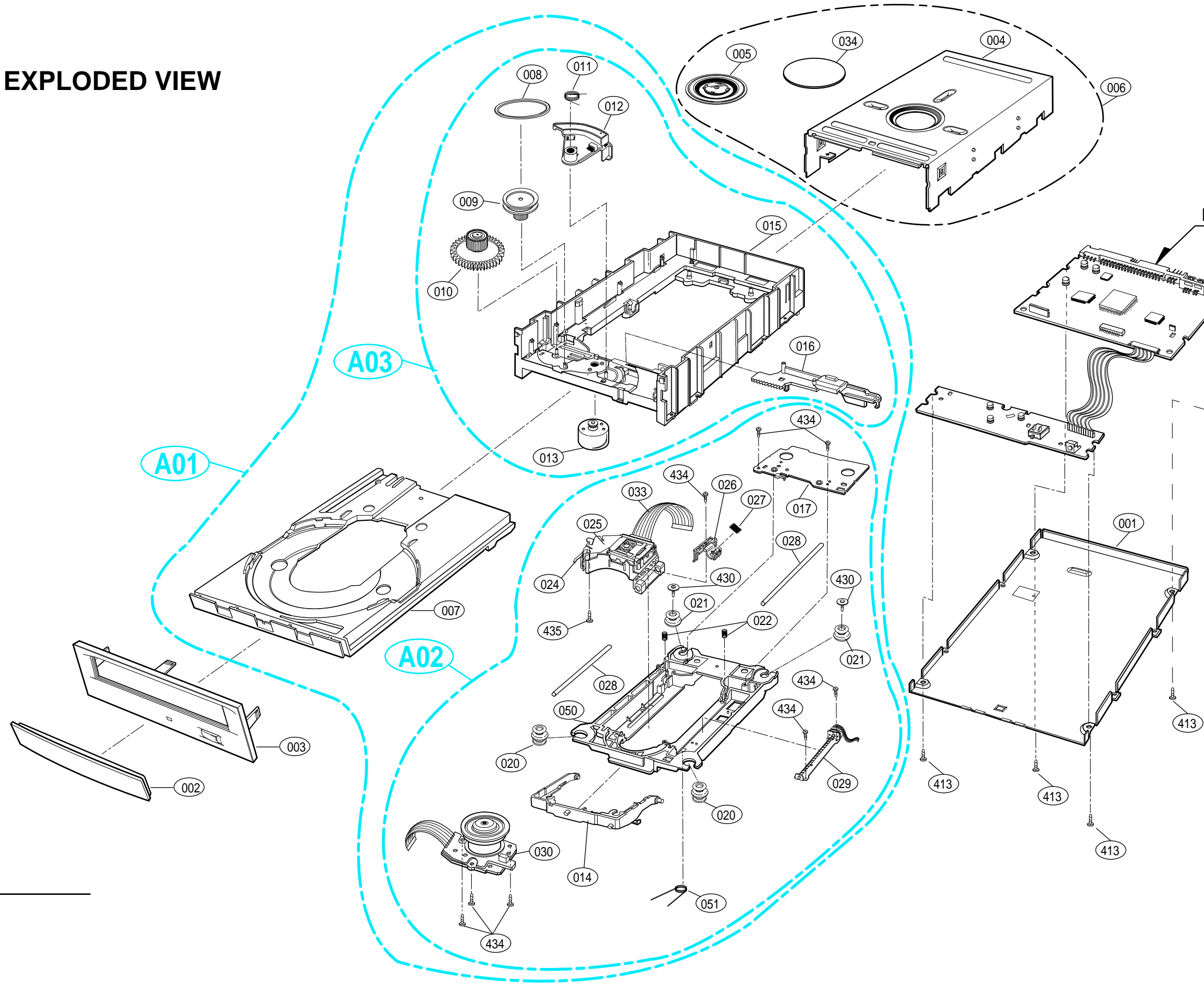

A B C D E F G H

7

8

# INTERNAL STRUCTURE OF THE PICK-UP

## 1. Structure of the Pick-Up

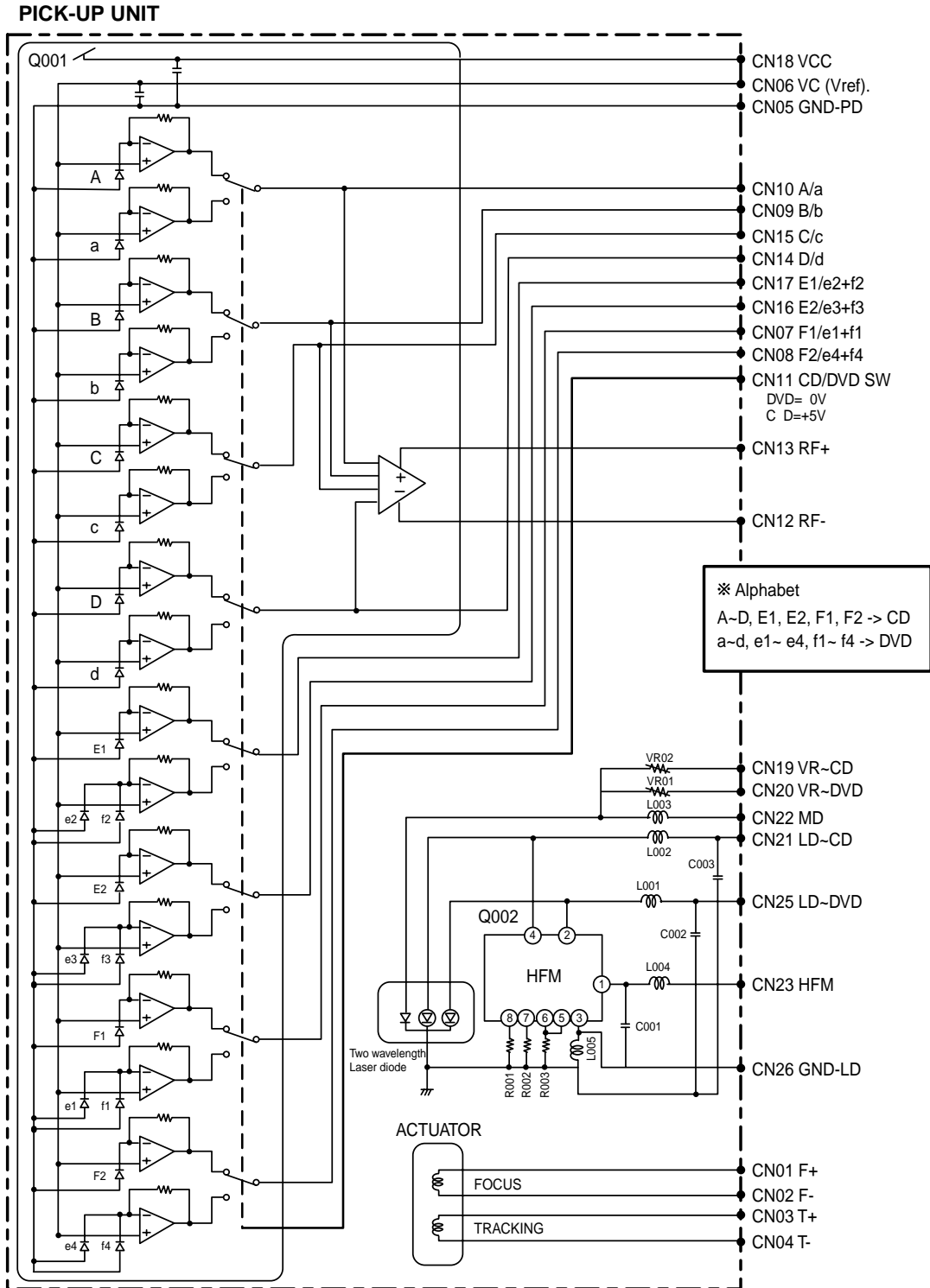



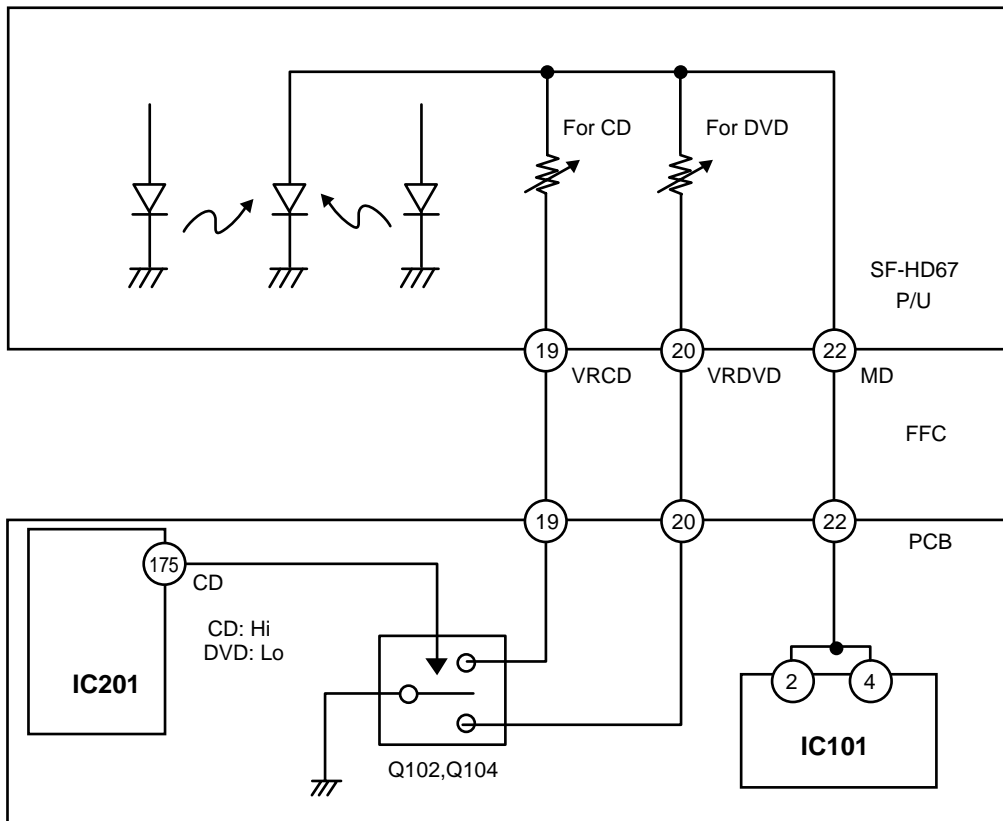

**Monitor resistor SW circuit**

### 1. Structure of the Pick-up

SF-HD67 is consist of monitor diode for DVD laser and CD laser.

When DVD laser is ON, CN101 20 Pin is need to connect GND for getting monitor voltage.(CN101 22 pin).

When CD laser is ON, CN101 19 Pin is need to connect GND for getting monitor voltage.(CN101 22 pin).

This control is done by handling Q102,Q104 from CD signal (IC201 175 pin output).

## 2. Structure of the Photo Diode (CD)

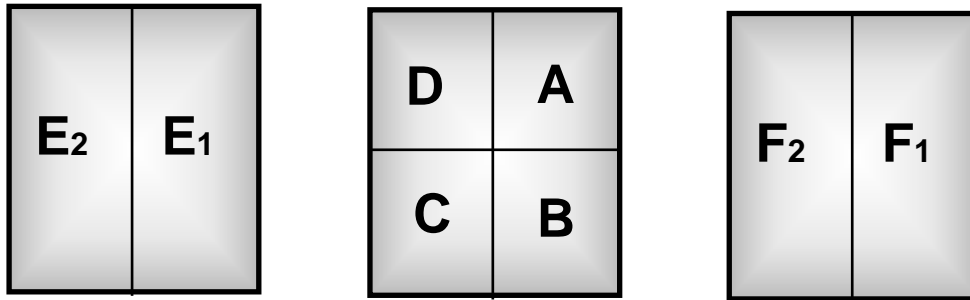

(As seen from light receiving side)

### 1) Focus Error Signal $\rightarrow (A + C) - (B+C)$

- In case of CD Disc

This signal is generated in RF AMP IC (IC101) and controls the pick-up's up and down to focus on CD Disc.

### 2) Tracking Error Signal (DPP( Differential Push Pull )) $\rightarrow \{(A+B) - (C+D)\} - 1.9 \times \{(E_1+F_1) - (E_2+F_2)\}$

- In case of CD Disc

This signal is generated in RF AMP IC (IC101) and controls the pick-up's left and right shift to find the track on CD Disc.

### 3) RF Signal $\rightarrow A+B+C+D$

- In case of CD Disc

This signal is converted to DATA signal in DSP IC (IC201).

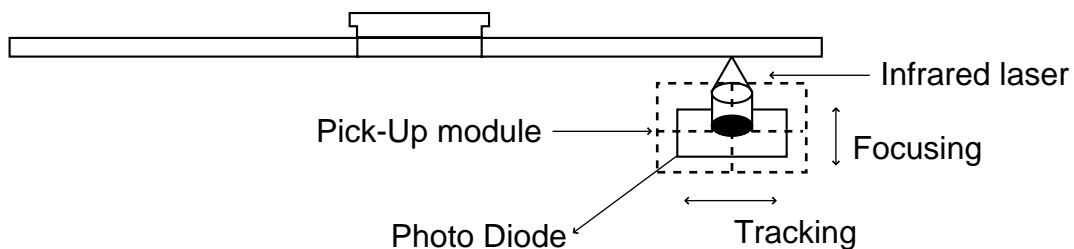

### 3. Structure of the Photo Diode (DVD-ROM)

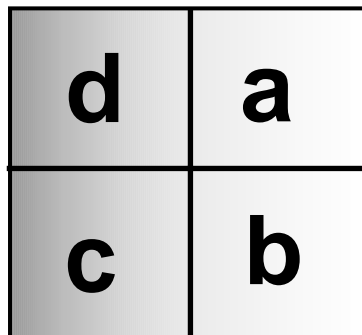

(As seen from light receiving side)

#### 1) Focus Error Signal $\rightarrow (a+c) - (b+d)$

- In case of DVD Disc

This signal is generated in RF AMP IC (IC101) and controls the pick-up's up and down to focus on DVD Disc.

#### 2) Tracking Error Signal (DPD Method) $\rightarrow$ Differential phase of A and B + Differential phase of C and D

- In case of DVD Disc

This signal is generated in RF AMP IC (IC101) and controls the pick-up's left and right shift to find the track on DVD Disc.

#### 3) RF Signal $\rightarrow (a+b+c+d)$

- In case of DVD Disc

This signal is converted to DATA signal in DSP IC (IC201).

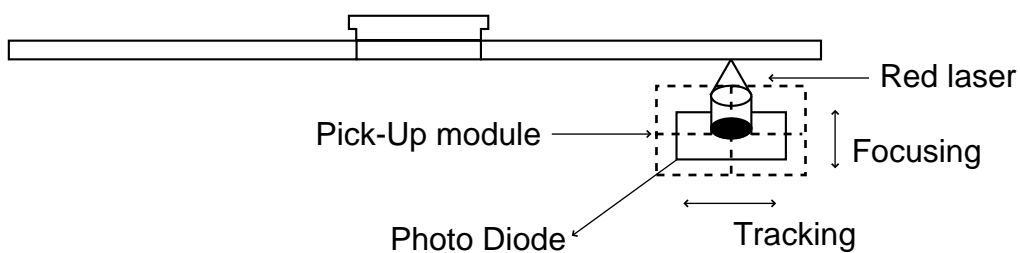

#### 4. Structure of the Photo Diode (DVD-RAM)

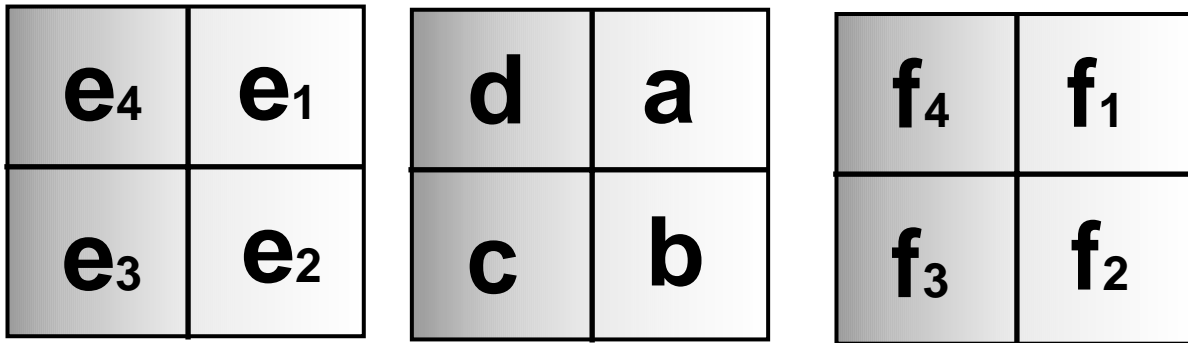

(As seen from light receiving side)

##### 1) Focus Error Signal $\rightarrow \{(a+c) - (b+d)\} - 1.17 \times \{(e_2 + f_2 + e_4 + f_4) - (e_1 + f_1 - e_3 + f_3)\}$

- In case of DVD Disc

This signal is generated in RF AMP IC (IC101) and controls the pick-up's up and down to focus on DVD Disc.

##### 2) Tracking Error Signal (DPP Method) $\rightarrow \{(a+b) - (c+d)\} - 1.17 \times \{(e_1 + f_1 + e_2 + f_2) - (e_3 + f_3 + e_4 + f_4)\}$

- In case of DVD Disc

This signal is generated in RF AMP IC (IC101) and controls the pick-up's left and right shift to find the track on DVD Disc.

##### 3) RF Signal $\rightarrow A+B+C+D$

- In case of DVD Disc

This signal is converted to DATA signal in DSP IC (IC201).

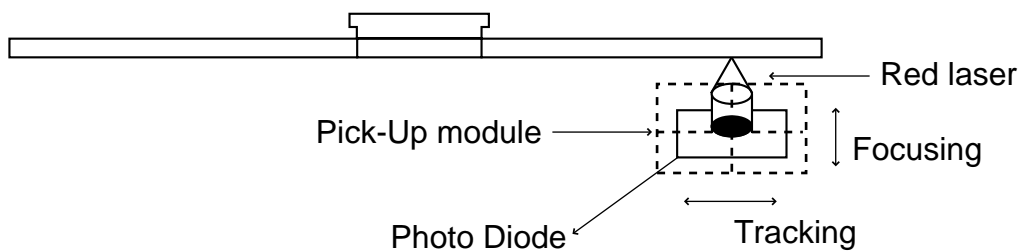

# DESCRIPTION OF CIRCUIT

## 1. ALPC (Automatic laser power control)

### 1-1. ALPC Circuit Constitution

Dual laser power control for DVD and CD are provided.

The laser ON for DVD or CD can be selected by  $LDSEL_i$  and the lasers ON/OFF are controlled by  $LDOFF_i$  -

Laser power for DVD and CD can be programmable by  $LDPWR_{0,1}_i$  -

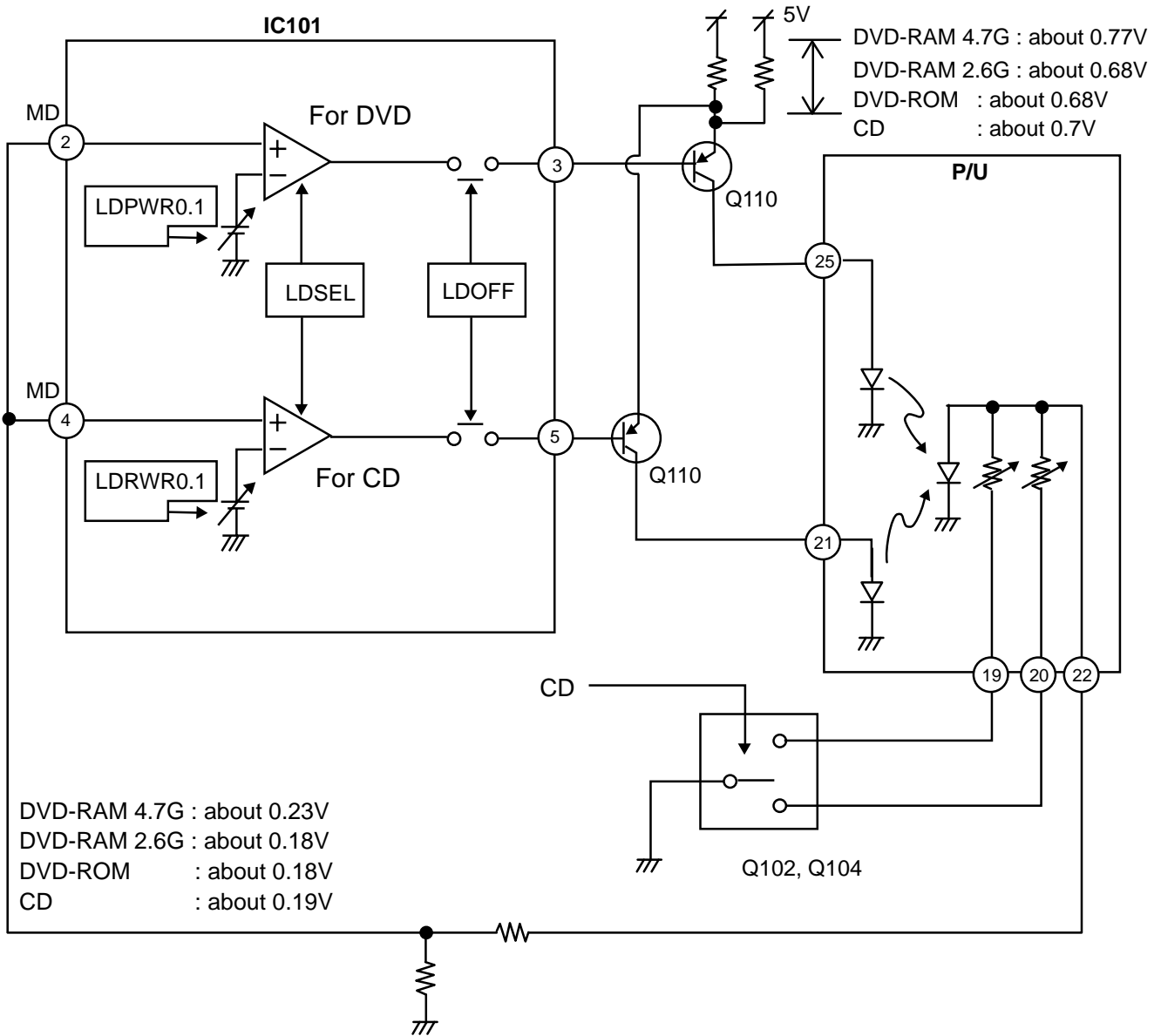

ALPC (Automatic laser plower control)

## 2. RF Amplifier Circuit

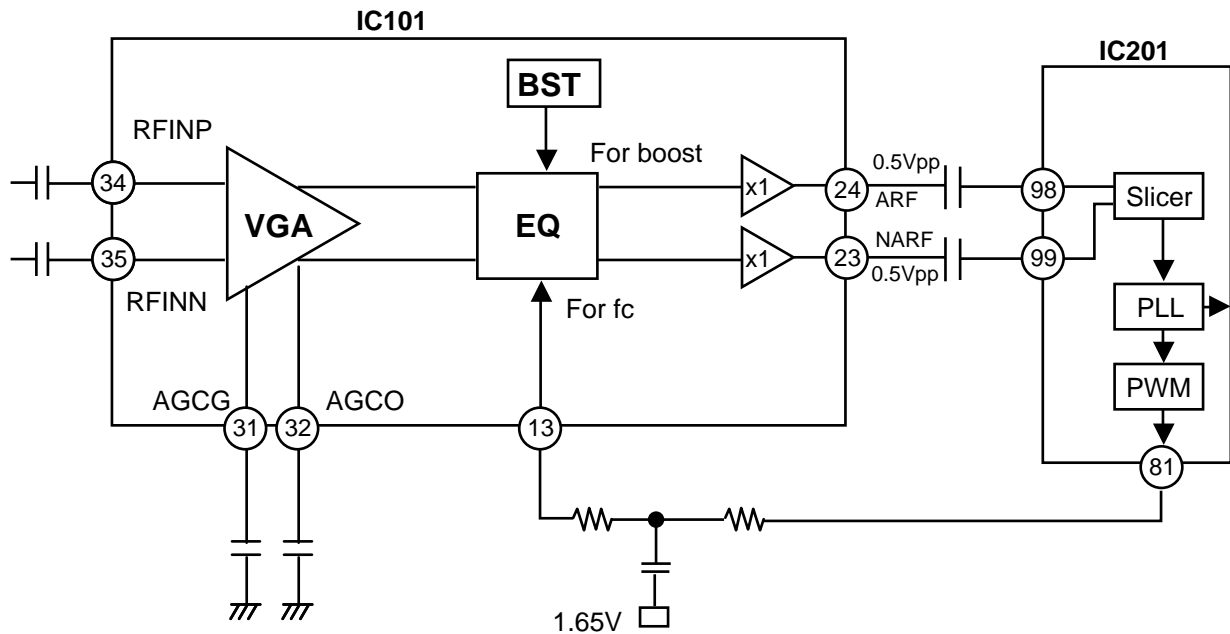

**RF Amplifier Circuit**

### 2-1. Input stage

The differential RF signal for data read from pick up may feed into IC101 pin 34 and pin 35.

### 2-2. AGC (Automatic Gain Control) Loop

This RF signal is controlled to 0.5 Vpp in VGA.

The capacitor which is connected in 31 pin is used to control constant level of amplitude.

The capacitor which is connected in 32 pin is used to control DC offset of RF signal.

### 2-3. Equalizer

EQ boost gain is controlled by u-com and register;  $BST_i$  -

Fc of EQ is linear by real velocity and feed into IC101 13pin and changed by current differentially.

### 3. SERVO SIGNAL

#### 3-1. FOCUSING ERROR (FE)

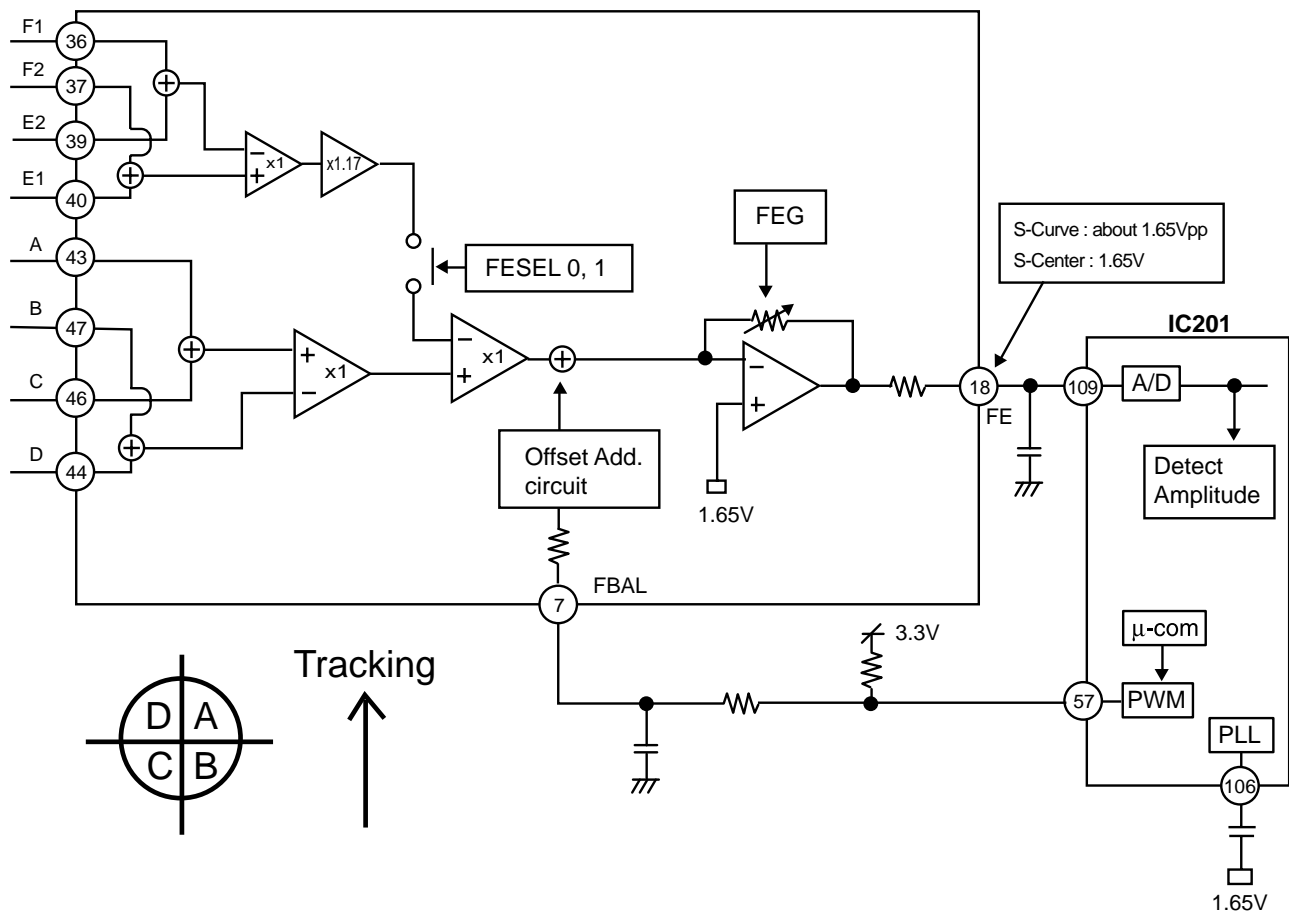

**Focusing Error circuit**

FE for DVD-ROM,CD are made from 4D(A,B,C,D).

FE S-curve amplitude is detected from IC201 109 pin and FE gain is controlled by register "FEG" to keep 1.65V amplitude.

Center Voltage of FE is about 1.65V.

Offset adjustment for added FE keep max voltage with jitter min.

Added offset quantity is programmable by current which feed into IC101 7 pin from IC201 57 pin.

FE for DVD-RAM 2.6G,4.7G is obtained from 4D(A,B,C,D) or sub spot(Sub beam) (E1,E2,F1,F2).

For DVD-RAM 2.6G, 4.7G, offset is occurred when track is crossed.

The reason for sub spot(sub beam) add is cancel of offset.

### 3-2. AS (ALL SUM)

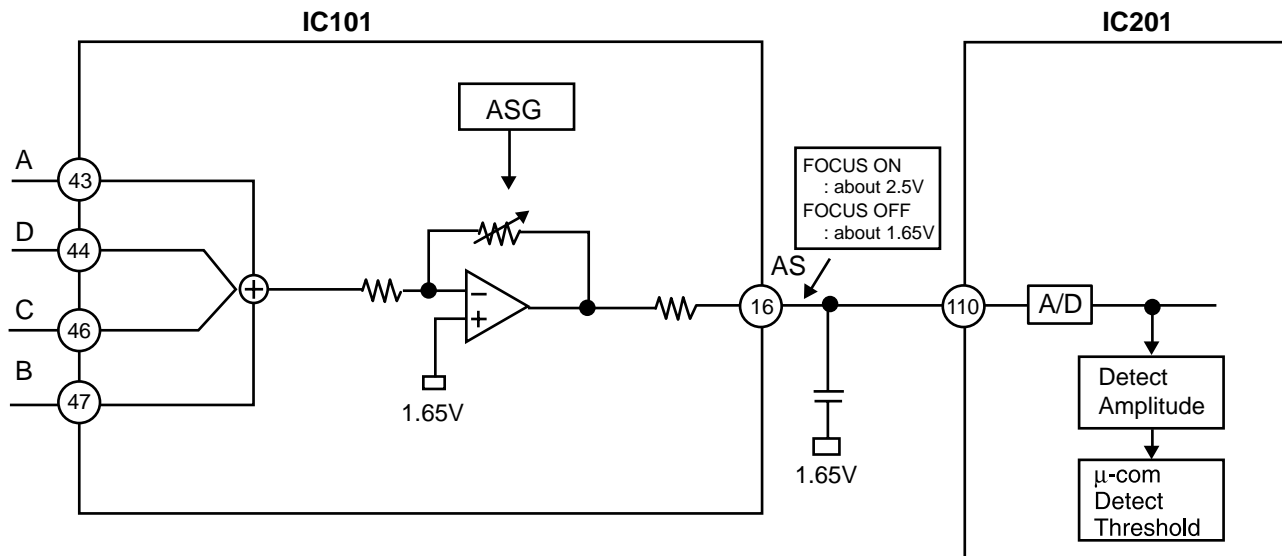

**AS circuit**

AS(All sum) signal is obtained from low pass filter and FOK is made from AS signal in IC201. This FOK signal is used to check servo status.

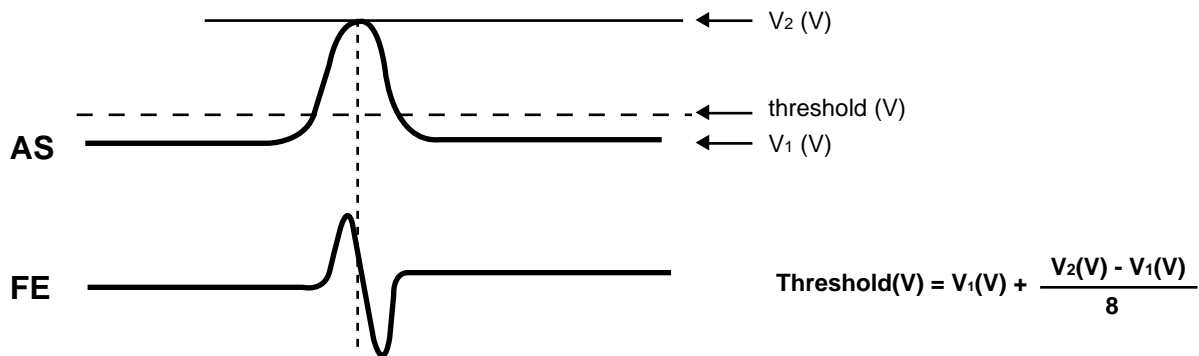

Threshold is that compare with AS signal to obtain FOK signal. Threshold can be made to focus sweep(Training) in initial read.



### 3-3. TRACKING ERROR (TE)

#### 3-3-1. TE for DVD-ROM (DPD)

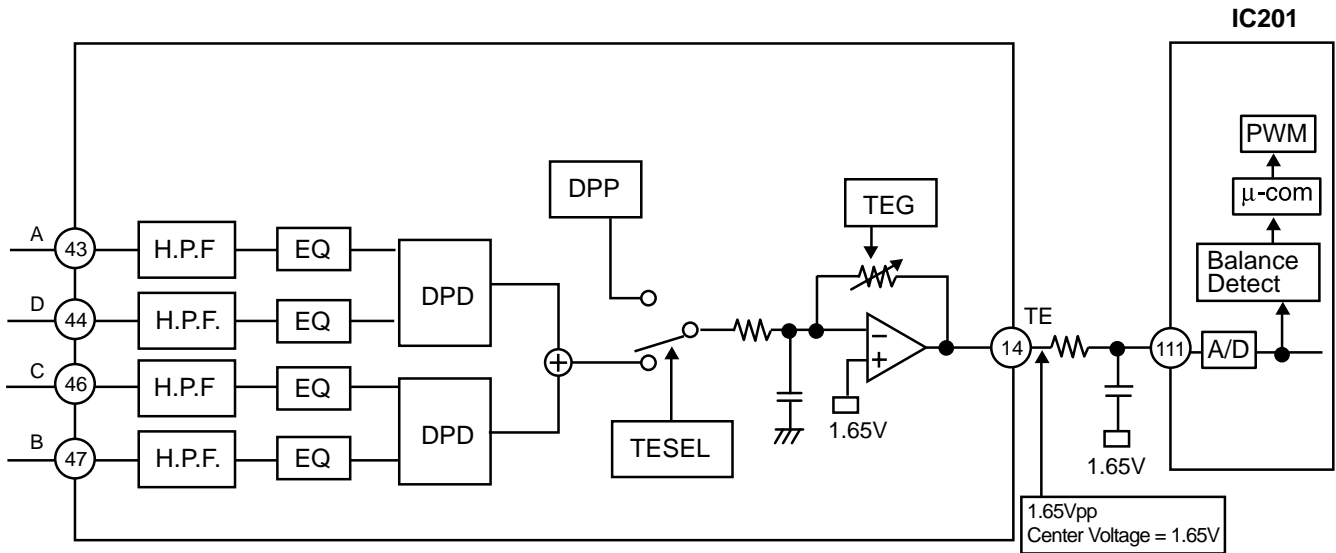

**Tracking error Circuit**

TE signal for DVD-ROM is made by DPD (Differential Phase Detect) method.

TE signal is made that add voltage obtain form phase differenece of front spot A, D to voltage obtain two phase difference of rear spot B, C.

Final stage amp gain is determined by register "TEG" and TE signal amplitude is about 1.65Vpp. (Center voltage of TE signal is about 1.65V)

Balance of TE signal center voltage is 1.65V.

Adjustment is operated by monitoring TE signal balance which feed into IC201 111pin.

### 3-3-2. TE for DVD-RAM, CD (DPP)

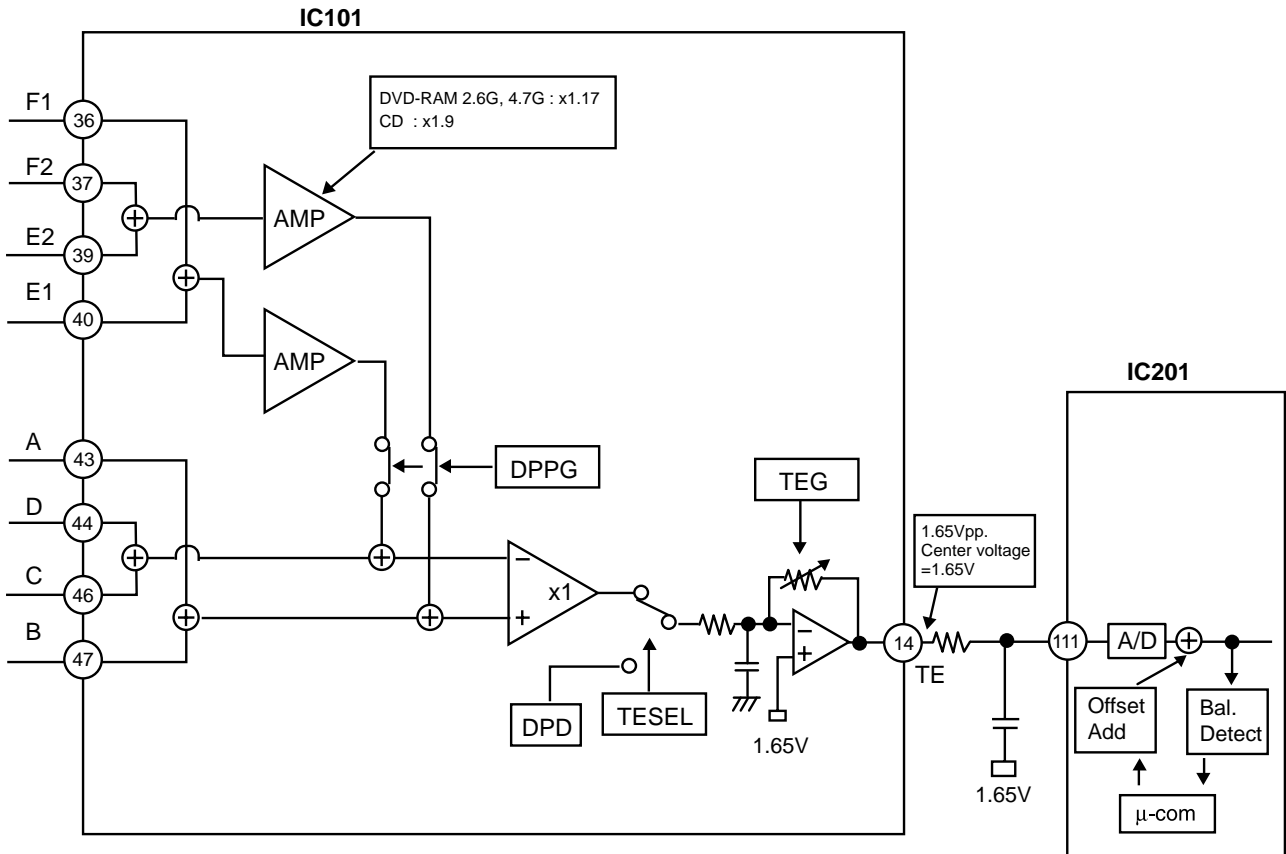

**Tracking error Circuit**

TE signal for DVD-RAM 2.6G,4.7G is programmable by DPP.

In case of DVD-RAM,sub spot(sub beam) is amplified by 1.17times and 1.9times in case of CD and add into main spot(main beam).

The reason of adding sub is that controlling offset(Offset cancel) which is occurred at lens shift.

Beam adjustment for center voltage(1.65V) of TE signal is done by adding TE signal which feed into IC201 111pin during initialization to offset.

### 3-4. LNSC (LENS CENTER SIGNAL)

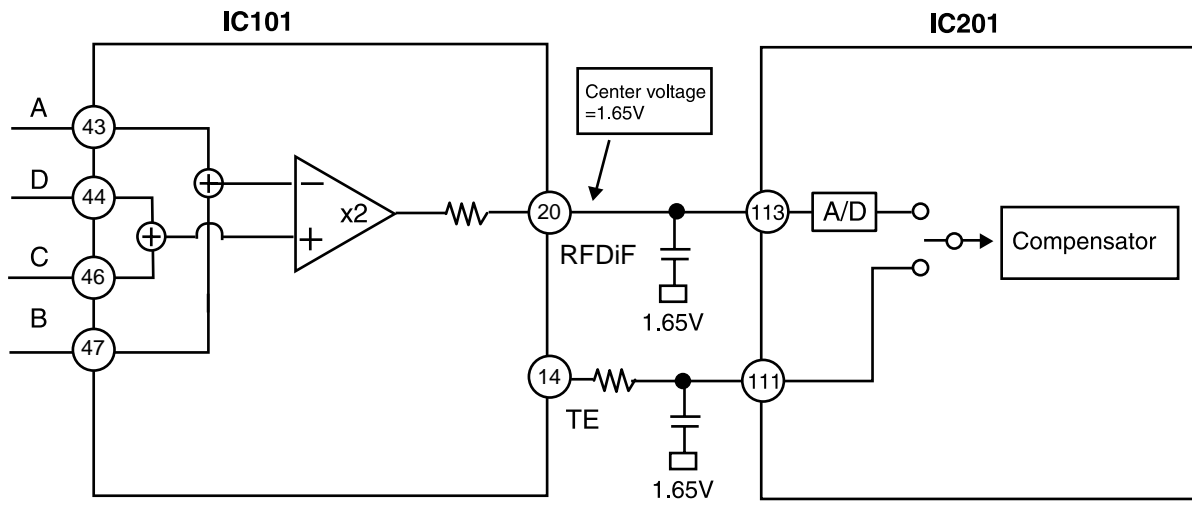

**LNSC Circuit**

RFDiF(LNSC) signal is used as error signal for tracking servo.  
This signal is used only for long seek (about 1000 track seek).  
This signal make lens fixed at detector center.

### 3-5. FOCUS SERVO

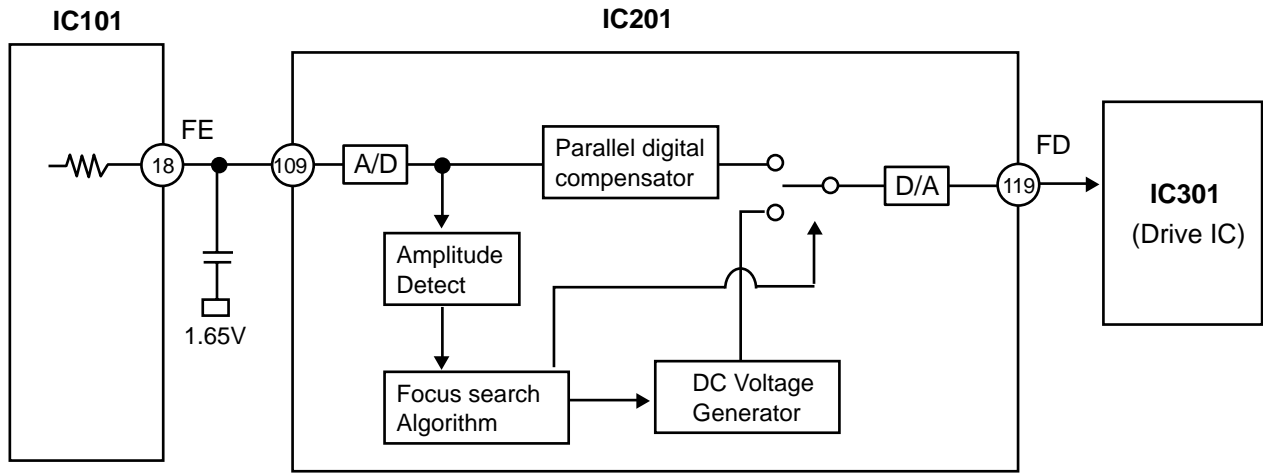

**Focus servo system**

Focus servo system is used to find focus ON point and to trace focus actuator into focus point using parallel digital compensator.

Refer to below focus search diagram.

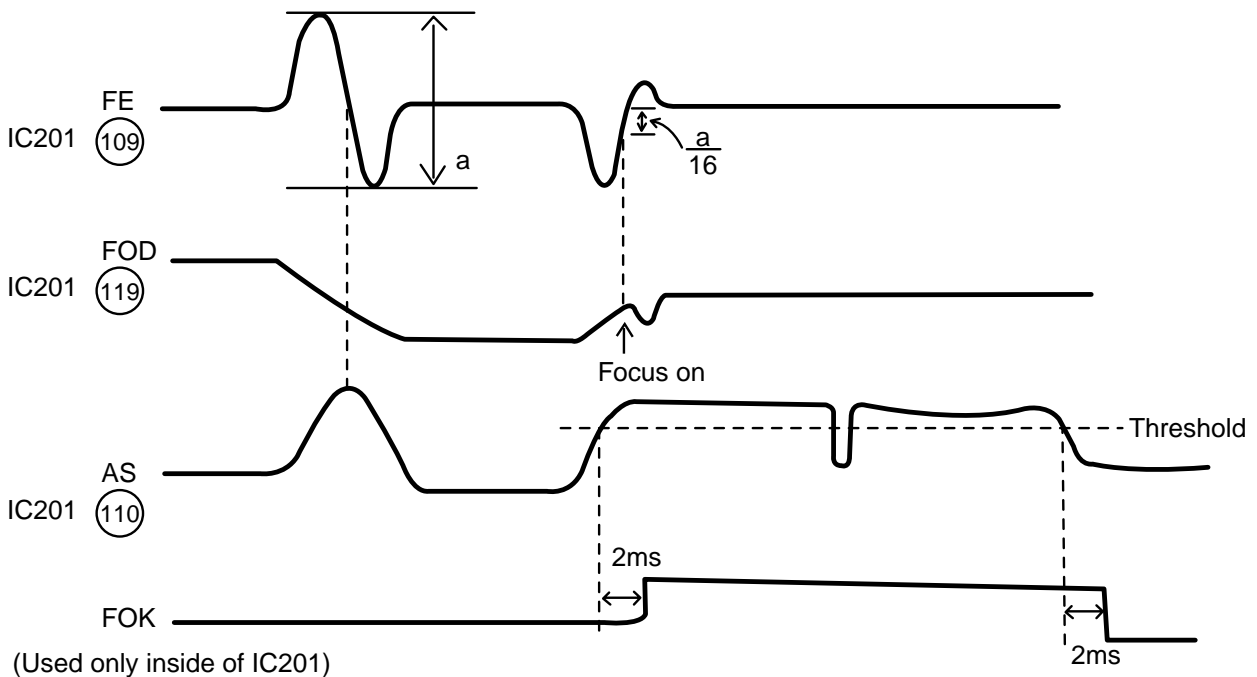

**Focus search diagram**

1. Light laser on through the IC101.
2. Move lens up or down and determine disk. Check amplitude of AS signal to make FOK.
3. Move lens up and down, find S-curve amplitude of FE.
4. Move lens down and up, monitor FE voltage. If [reference voltage (about 1.65V) - FE s-curve amplitude/8], close servo loop and focus ON.
5. If AS signal is 2ms higher than threshold, FOK is "H" and focus servo is ok.

When AS is 2ms lower than threshold, FOK is "L".

FOK is using only in IC201, not in IC 201. (Impossible to FOK signal check with termina of IC201)

### 3-6. TRACKING SERVO SYSTEM

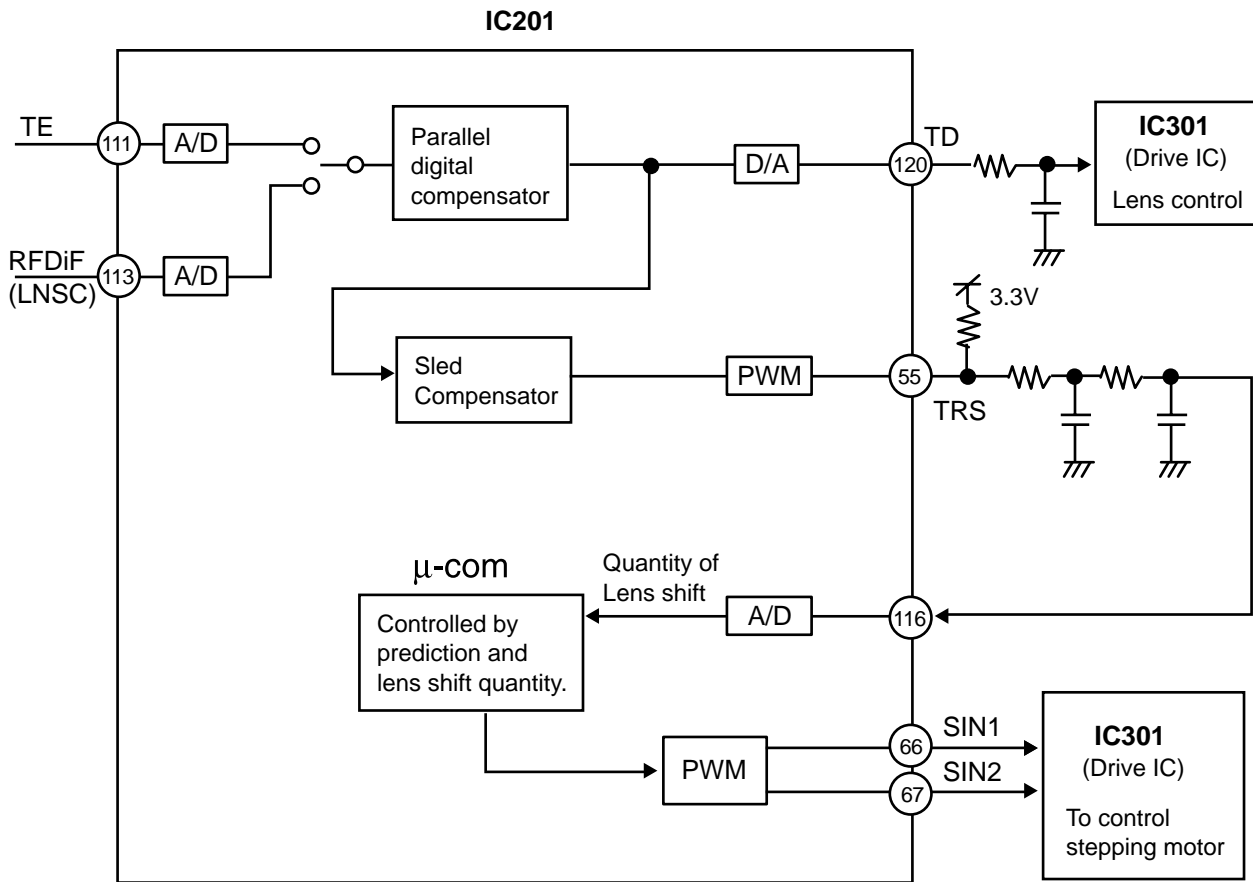

**Tracking servo system**

Tracking servo is used to follow trace center of detector with TE signal and to control stepping motor. Tracking servo make lens into center of detector using RFDiF(LNCS) signal. TE signal is sampled by A/D converter during sequential read and do gain compensation, phase compensation in parallel digital compensator.

This signal is changed to analog signal in D/A converter and feed into Drive IC301 from IC201 120 pin and operate tracking actuator. Control of stepping motor(sled motor) is decided by disk and rotation speed, and control signal output is obtained by IC201 66 and 67 pin.

If large lens shift, detected lens shift quantity by IC201 pin 116 and compensated by u-com. During long seek, LNCS is converted by A/D and compensated. Therefore servo is applied good and controlled detector in center.

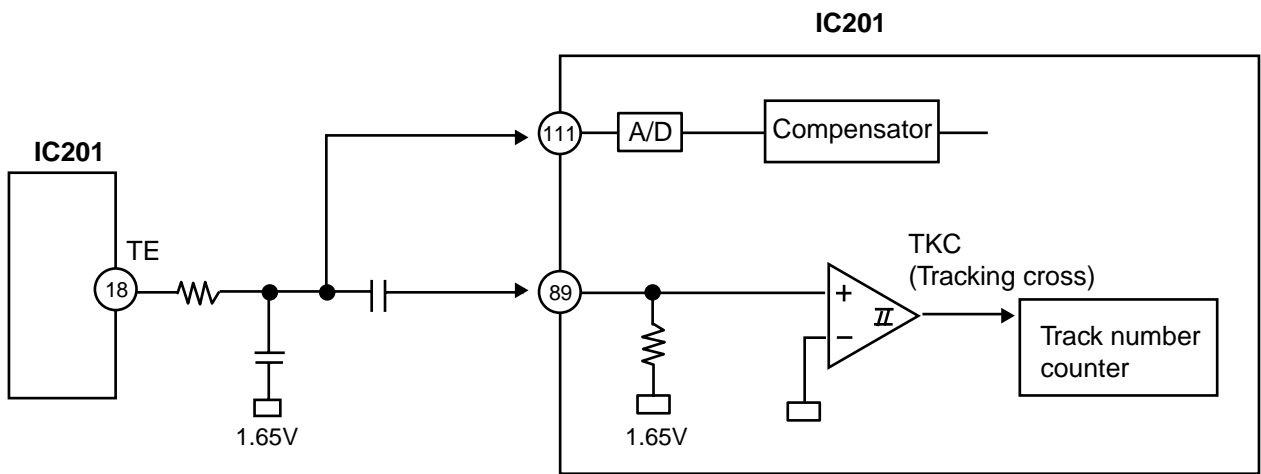

### Tracking cross for seek control

TKC is digital signal of "H", "L" which is compared to TE signal in center of amplitude.

TKC is used to make constant track cross speed and jumped track count in case of multi-jump (number of track: about less than 1000 track)in IC201.

#### 4. About DVD-RAM 2.6G, 4.7G signal

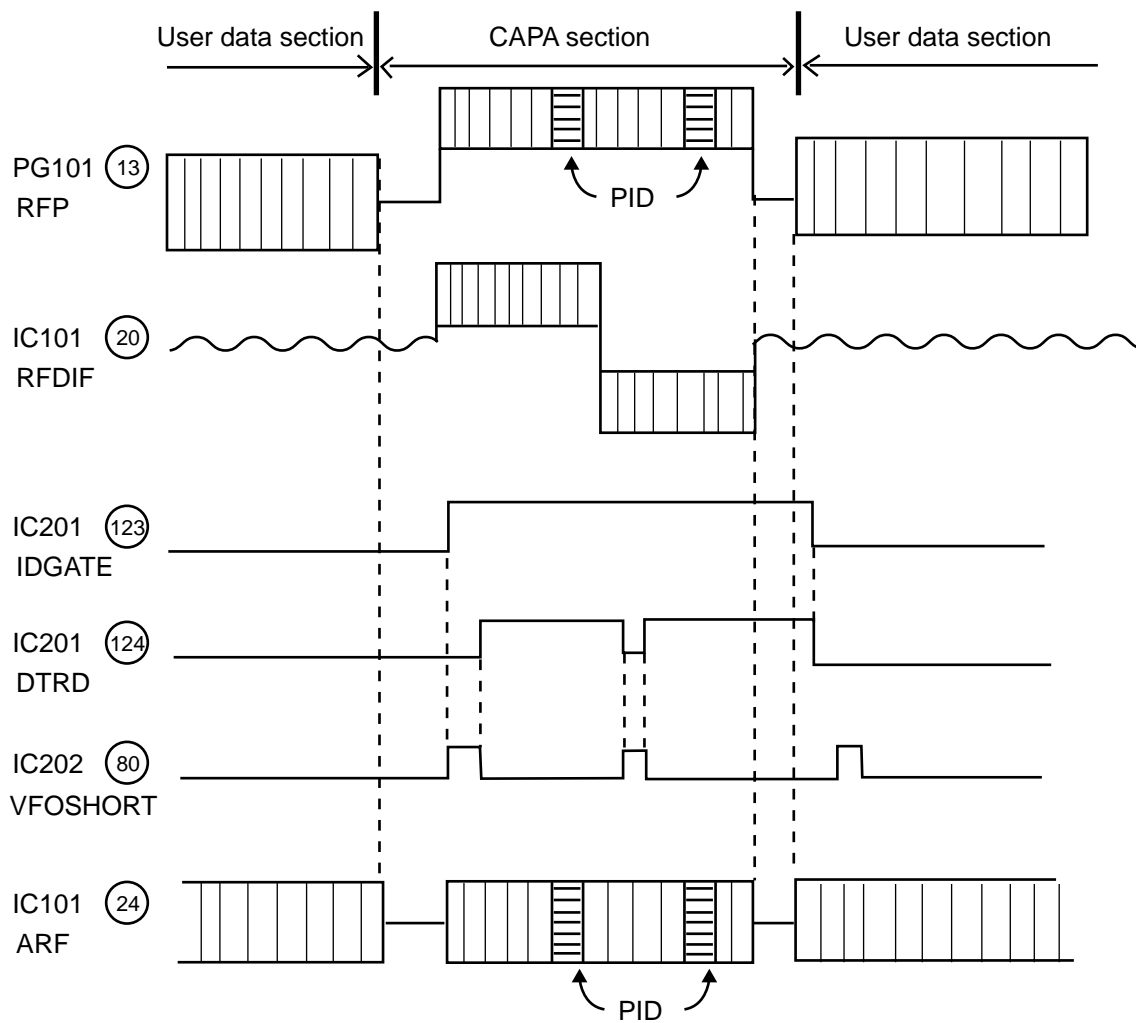

Signal timing for DVD-RAM 2.6G, 4.7G

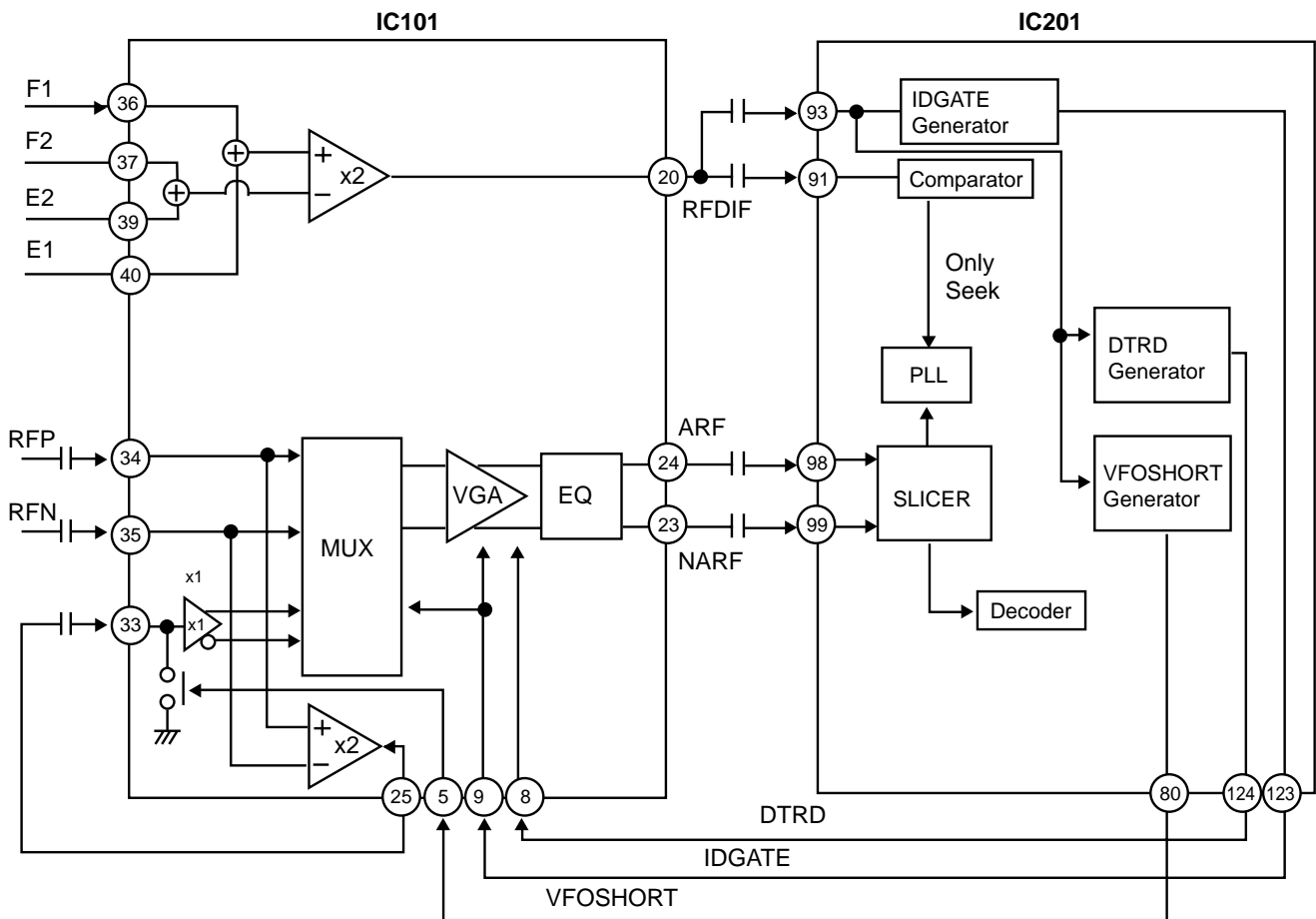

### DVD-RAM 2.6G, 4.7G system

DVD-RAM 2.6G, 4.7G have CAPA(Complementary Allocated Pit Address) different from DVD-ROM.

CAPA is consist of same pit like DVD-ROM disk, that's why even blank disk has it.

CAPA has PID(Physical ID) which shows address on disk.

DVD-RAM 2.6G, 4.7G use (RFDiF, IDGATE, DTRD, VFOSHORT) signal to read PID.

This signal is not used in DVD-ROM and CD-ROM.

- RFDiF signal : This signal is made from main 4D(main beam) in IC101 and sent to IC201. This signal is used of generation of IDGATE, DTRD, VFOSHORT signal in IC201. This signal is used to control PLL frequency for seek.
- IDGATE signal: This signal is made by RFDiF signal and PLL clock in IC201. IDGATE signal detect CAPA and input "H" to IC101. IDGATE signal is changed to RF signal of slicer of IC201 in IC101. When IDGATE signal is "H", it feed into IC101 34, 35 pin and CD offset is removed (For up to readability) and RF signal of CAPA is sent to IC201 slicer. When IDGATE is "L", it feed into IC101 34, 35 pin and user data RF signal is sent to IC201 slicer.
- DTRD signal : This signal is made by RFDiF signal and PLL clock in IC201. This signal is used for read of PID read and user data read timing in IC201. DTRD signal is sent to IC101 and used for hold of RFAGC. When DTRD signal is "L" and IDGATE is "L", RFAGC is held.
- VFOSHORT signal : This signal is made by RFDiF signal and PLL clock in IC201. VFOSHORT signal is "H" in front of CAPA and user data, RF signal is shorted and remove DC offset to read PID of CAPA and user data.



# DESCRIPTION OF DATA PROCESSING

## 1. Data Processing Flow

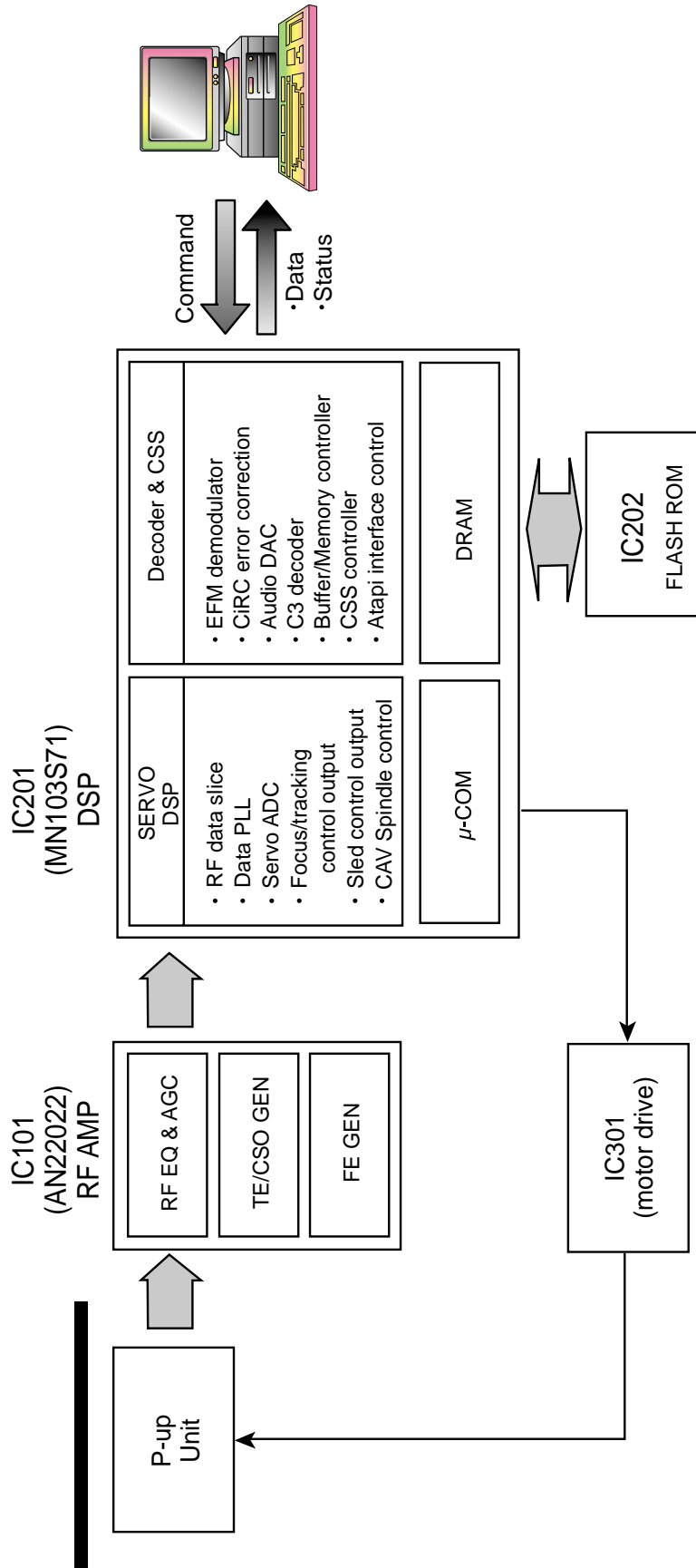

## 2. Copy Protection and Regional Code Management Block

### Block Diagram

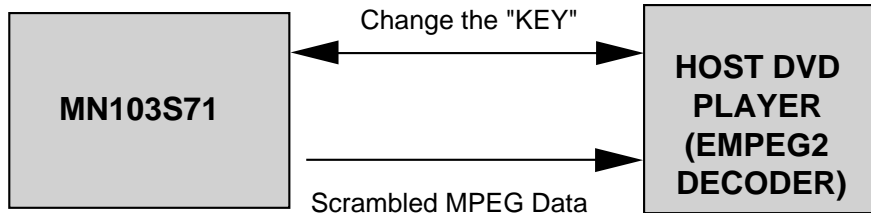

### KEY Management Control

#### Brief Process

##### 1. Regional Code for DVD Disc

- DVD-ROM drive transfers the regional code of the control data to host by the command of host, the DVD player of host reads the regional code, and plays title in the case of allowed regional code only.

##### 2. Management of DVD Disc for the scrambled of data

- (1) DVD-ROM and DVD player of host generate the "KEY 1" respectively, transfer to opposite part, the "KEY 2" is received, recognizes the data transfer or not with this value, and generates the bus key encoded the data.
- (2) Encoded "Disc Key" and "Title Key" host is transfer with the bus Key.
- (3) DVD player of host reads the key value, and uses the value to restore the scrambled data.

\* Refer to the next page for the details.

### 3. About Prevention the DVD-ROM from to be copy

A data is able to encode and record in the disc, if a copyright holder wants to prevent the disc from copying.

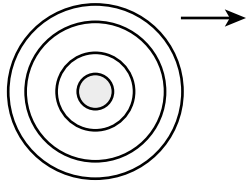

#### In case of a disc enhanced movie of 3 titles.....

DISC KEY (2048 Bytes) is used to encode the whole contents in the disc and TITLE KEY (5 Bytes) is used to encode the title respectively.

So, the data is encoded and stored in a disc through the unknown algorithms with a disc key and title key. (At this time, the disc key and title key are stored in a disc.)

...As above, the disc is able to copy when the disc key and title key are opened.

Then, ROM-DRIVE encodes the disc key and title key and transfers to MPEG-2 board.

#### If you want to play the disc prevented from the copy.....

First of all, ROM-DRIVE and MPEG-2 decoder identify with each other through the procedure as described below.

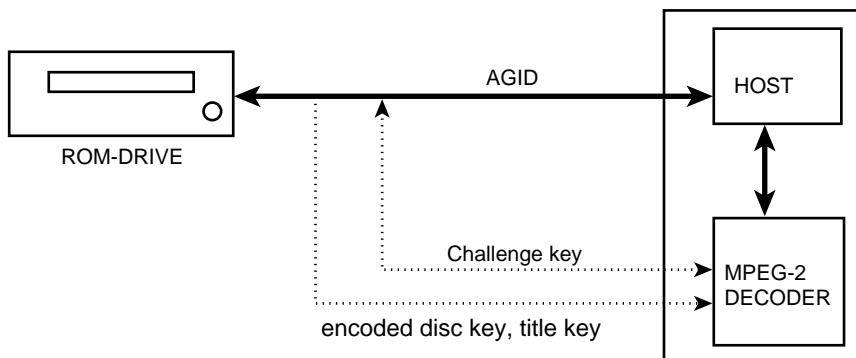

1. Drive and host gives and takes the ID of 2bit. This ID is AGID (Authentication Grant ID).  
The various decoder boards are attached to the host, in these, AGID sets the MPEG-2 decoder and drive.
2. After the AGID is set, MPEG-2 decoder generates the challenge key (10 Byte) and transfers to drive. The board and drive generate key 1 (5Byte) with the challenge key respectively. (Of course, the Algorithm generating the key 1 is not known.)
3. Compare with the generated key 1, if it corresponds each other, the first step of authentication is completed. This is a course to identify the MPEG-2 decoder with a drive.
4. The second step of authentication is a course to identify a drive with the MPEG-2 decoder.  
The dirve generates a challenge key and transfers it to the MPEG-2 decoder. The dirve and MPEG-2 decoder generate the key 2 (5Byte) with the challenge key, compare with each other, and if it corresponds and the secondary step of authentication is completed.
5. As above, the identification is completed.
6. The dirve and MPEG-2 decoder generate the Bus key with the key 1 and key 2 and own it.
7. Dirve encodes the disc key and title key with this Bus key and transfers to the MPEG-2 decoder.
8. The MPEG-2 decoder reads the encoded disc key and title key with the Bus key only.
9. MPEG-2 board lets data read from the drive to decode with the read disc key and title key and makes into the video signal by decoding.

## 4. About the DVD-ROM Regional Code

### Regional code

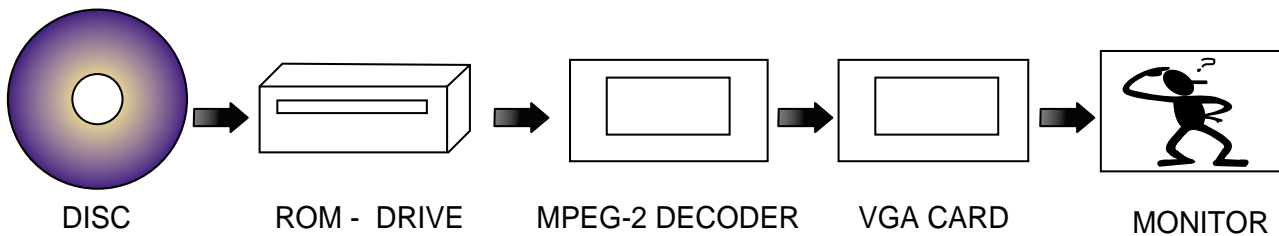
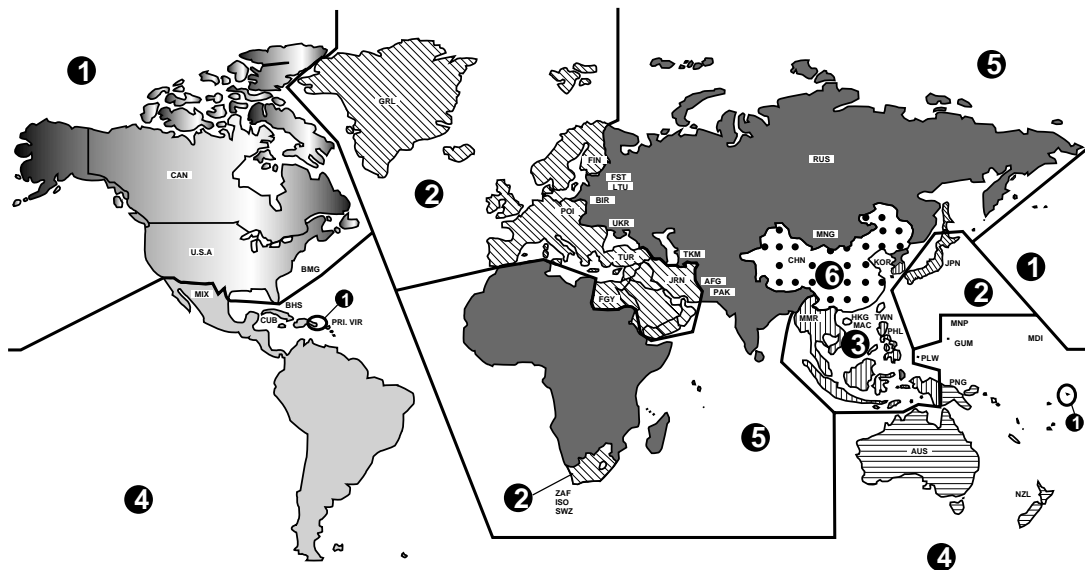

The disc has the regional code of 8 bit.

**Example)**  
The disc manufactured in the U.S.A., has the number one.

Transfer to MPEG-2 decoder reading the regional code.

If the board is setting to the regional code 1 for the U.S.A. ...  
Check the received regional code to number 1, all or not, transfer the data to VGA card in accordance with only a case among the three case.

Receiving data from the MPEG-2 decoder and output through the monitor

# MAJOR IC INTERNAL BLOCK DIAGRAM AND PIN DESCRIPTION

## IC101 (AN22022A)

### Block Diagram

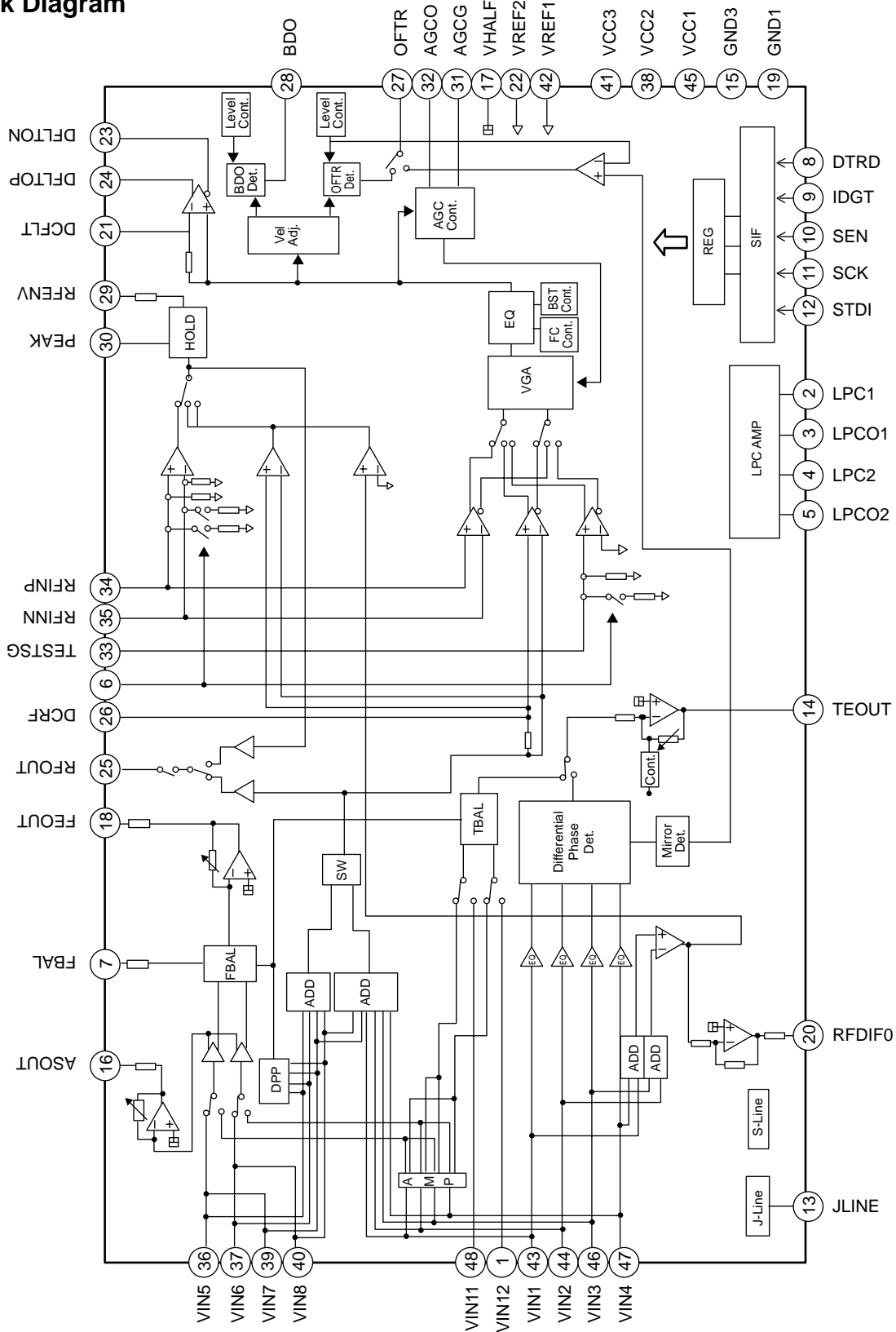

• Pin Description

No		Function	No		Function
1	VINI2	3-beam sub(cd) input 2	25	RFOUT	RF full-addition amplifier output
2	LPC1	Laser pin input (DVD head)	26	DCRF	DC-cut filter of RF full-addition amplifier
3	LPCO1	Laser drive output (DVD head)	27	OFTR	OFTR output
4	LPC2	Laser pin input (CD head)	28	BDO	BDO output
5	LPCO2	Laser drive output (CD head)	29	RFENV	RF envelope output
6	VFOSHORT	VFOSHORT control	30	PEAK	Peak envelope detection filter
7	FBAL	Focus balance control	31	AGCG	AGC amplifier gain control
8	DTRD	Data slice data read signal input (for RAM)	32	AGCO	AGC amplifier level control
9	IDGT	Data slice address gate signal input(for RAM)	33	TEST SG	TEST signal input
10	SEN	SEN (serial data input)	34	RFINP	RF signal positive input
11	SCK	SCK (serial data input)	35	RFINN	RF signal inverted input
12	STDI	STDI (serial data I/O)	36	VIN5	Internal four-partition (CD) RF input 1
13	JLINE	J-line current setting	37	VIN6	Internal four-partition (CD) RF input 2
14	TEOUT	Tracking error signal output	38	VCC2	Power supply 2 (5V)
15	GND3	Ground 3	39	VIN7	Internal four-partition (CD) RF input 3
16	ASOUT	Full addition signal output	40	VIN8	Internal four-partition (CD) RF input 4
17	VHALF	VHALF voltage output	41	VCC3	Power supply 3 (3.3V)
18	FEOUT	Focus error signal output	42	VREF1	VREF1 voltage output
19	GND1	Ground 1	43	VIN1	Internal four-partition (DVD) RF input 1
20	RFDIFO	Radial differential output	44	VIN2	Internal four-partition (DVD) RF input 2
21	DCFLT	Filter output capacitance connection	45	VCC1	Power supply 1 (5V)
22	VREF2	VREF2 voltage output	46	VIN3	Internal four-partition (DVD) RF input 3
23	DFLTON	Filter amplifier inverted output	47	VIN4	Internal four-partition (DVD) RF input 4
24	DFLTOP	Filter amplifier positive output	48	VIN11	3-beam sub (CD) input 1

# IC201 (MN103S71) DSP & Interface LSI

## Block Diagram

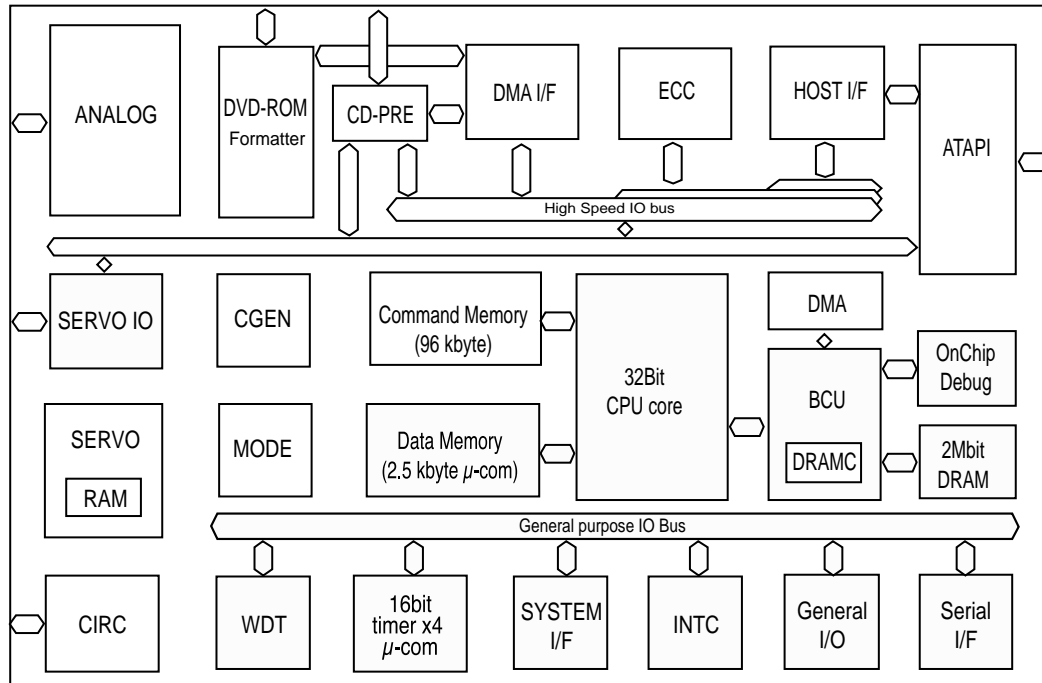

• Pin Assignment

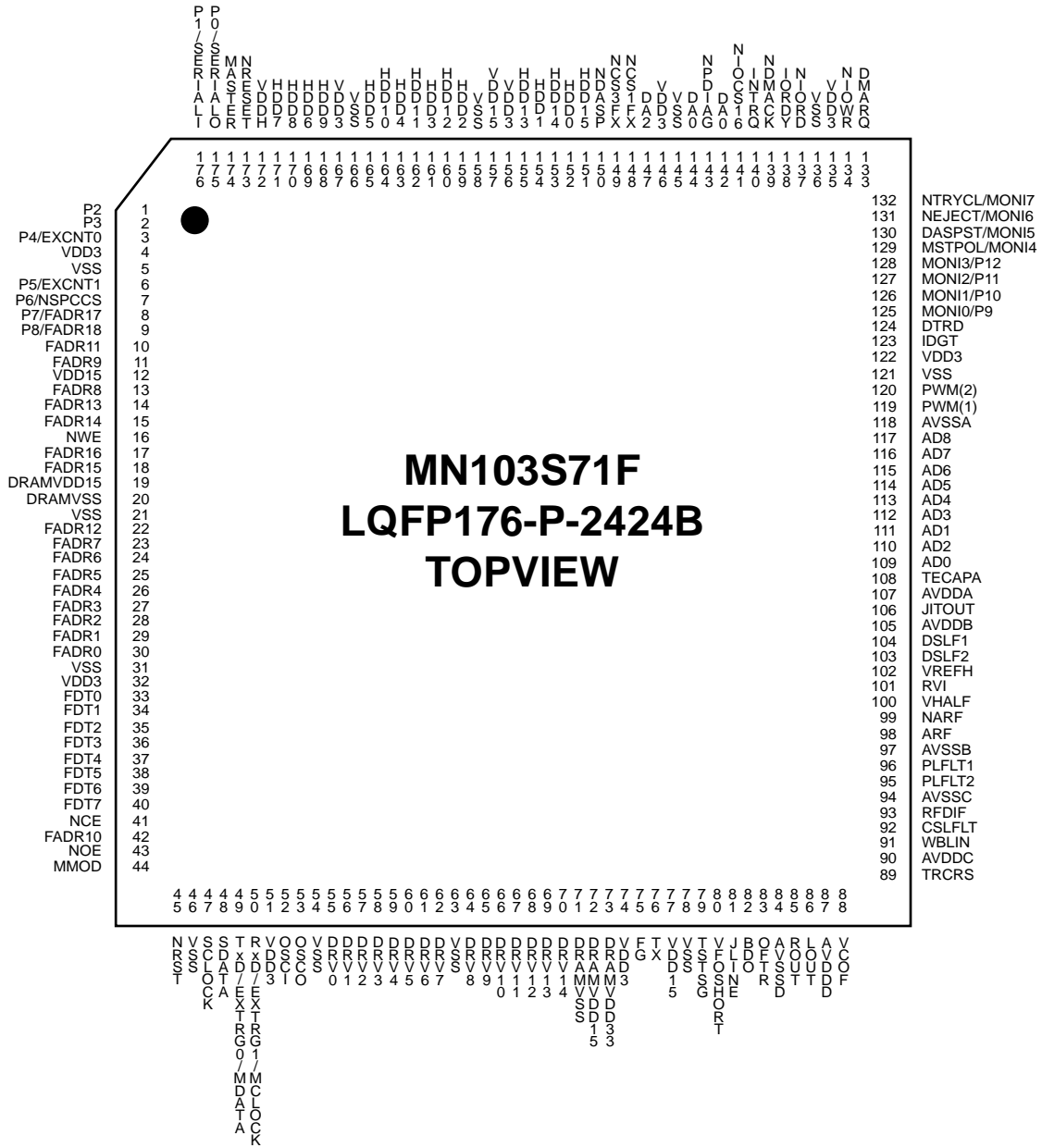



## • Pin Description

Pin No	Pin name	I/O	Connect to	Description
1	P2	I/O		General purpose port
2	P3	I/O		General purpose port
3	P4/EXCNT0	I/O		General purpose port / External terminal count
4	VDD3	Power	-	VDD (3.3V)
5	VSS	GND	-	VSS
6	P5/EXCNT1	I/O		General purpose port / External terminal count
7	P6/NSPCCS	I/O		General purpose port / SPC CS
8	P7/FADR17	I/O	toFLASH	General purpose port / FLASH address out
9	P8/FADR18	O	toFLASH	General purpose port / FLASH address out
10	FADR11	O	toFLASH	FLASH address out
11	FADR9	O	toFLASH	FLASH address out
12	VDD15	Power	-	VDD (1.5V)
13	FADR8	O	toFLASH	FLASH address out
14	FADR13	O	toFLASH	FLASH address out
15	FADR14	O	toFLASH	FLASH address out
16	NWE	O	toFLASH	FLASH Write signal out
17	FADR16	O	toFLASH	FLASH address out
18	FADR15	O	toFLASH	FLASH address out
19	DRAMVDD15	Power	-	DRAM VDD(1.5V)
20	DRAMVSS	GND	-	DRAM VSS
21	VSS	GND	-	VSS
22	FADR12	O	toFLASH	FLASH address out
23	FADR7	O	toFLASH	FLASH address out
24	FADR6	O	toFLASH	FLASH address out
25	FADR5	O	toFLASH	FLASH address out
26	FADR4	O	toFLASH	FLASH address out
27	FADR3	O	toFLASH	FLASH address out
28	FADR2	O	toFLASH	FLASH address out
29	FADR1	O	toFLASH	FLASH address out
30	FADR0	O	toFLASH	FLASH address out
31	VSS	GND	-	VSS
32	VDD3	Power	-	VDD (3.3V)
33	FDT0	I/O	toFLASH	FLASH data In/out
34	FDT1	I/O	toFLASH	FLASH data In/out
35	FDT2	I/O	toFLASH	FLASH data In/out
36	FDT3	I/O	toFLASH	FLASH data In/out
37	FDT4	I/O	toFLASH	FLASH data In/out
38	FDT5	I/O	toFLASH	FLASH data In/out

Pin No	Pin name	I/O	Connect to	Description
39	FDT6	I/O	toFLASH	FLASH data In/out
40	FDT7	I/O	toFLASH	FLASH data In/out
41	NCE	O	toFLASH	FLASH chip reset signal out
42	FADR10	O	toFLASH	FLASH address out
43	NOE	O	toFLASH	FLASH read signal out
44	MMOD	I	-	Test mode change signal
45	NRST	I	fromRSTIC	Reset input
46	VSS	GND	-	VSS
47	SCLOCK	I/O	-	DWire data pin *1
48	SDATA	I/O	-	DWire data pin *1
49	TxD/EXTRG0/MDATA	I/O	-	Serial send/DWire trigger pin *2
50	RxD/EXTRG1/MCLOCK	I/O	-	Serial receiver/DWire trigger pin *2
51	VDD3	Power	-	VDD (3.3V)
52	OSCI	I	X'tal	OSC input (16.9344MHz)
53	OSCO	O	X'tal	OSC output (16.9344MHz)
54	VSS	GND	-	VSS
55	DRV0	I/O	toDRIVEIC	Traverse drive out/General port
56	DRV1	I/O	toDRIVEIC	Spindle drive output
57	DRV2	I/O	toFEP	Focus Balance ADJ output
58	DRV3	I/O	toFEP	Tracking balance ADJ output
59	DRV4	I/O		General purpose port
60	DRV5	I/O		General purpose port
61	DRV6	I/O		General purpose port
62	DRV7	I/O		General purpose port
63	VSS	GND	-	VSS
64	DRV8	I/O		General purpose port
65	DRV9	I/O		General purpose port
66	DRV10	I/O		General purpose port
67	DRV11	I/O		General purpose port
68	DRV12	I/O	toFEP	FEP clock out
69	DRV13	I/O	toFEP	FEP data out
70	DRV14	I/O	toFEP	FEP enable signal
71	DRAMVSS	GND	-	DRAM VSS
72	DRAMVDD15	Power	-	DRAM (1.5V)
73	DRAMVDD33	power	-	DRAM (3.3V)
74	VDD3	Power	-	VDD (3.3V)
75	FG	I	fromDRVIC	Monitor FG input
76	TX	O	-	Digital out

Pin No	Pin name	I/O	Connect to	Description
77	VDD15	Power	-	VDD (1.5V)
78	VSS	GND	-	VSS
79	TSTSG	O	toFEP	EQ calibration signal
80	VFOSHORT	O	toFEP	VFO short output
81	JLINE	O	toFEP	J-line setting output
82	BDO	I	fromFEP	Drop out signal input
83	OFTR	I	fromFEP	Off track signal input
84	AVSSD	GND	-	Analog VSS
85	ROUT	O	-	MASH Rch audio output
86	LOUT	O	-	MASH Lch audio output
87	AVDDD	Power	-	Analog VDD (3.3V)
88	VCOF	I	-	JFVCO control voltage
89	TRCRS	I	fromFEP	Signal input for track cross generation
90	AVDDC	Power	-	Analog VDD (3.3V)
91	WBLIN	I	-	WBL input
92	CSLFLT	I	-	CPDET condenser
93	RFDIF	I	-	CPDET RF input
94	AVSSC	GND	-	Analog VSS
95	PLFLT2	I	-	PLL condenser 2
96	PLFLT1	I	-	PLL condenser 1
97	AVSSB	GND	-	Analog VSS
98	ARF	I	fromFEP	Equivalent RF+ input
99	NARF	I	fromFEP	Equivalent RF- input
100	VHALF	I	fromFEP	Reference voltage 1.65V input
101	RVI	I	-	VREFH reference current, resistor
102	VREFH	I	fromFEP	Reference voltage 2.2V input
103	DSL2	I	-	DSL condenser 2
104	DSL1	I	-	DSL condenser 1
105	AVDDB	Power	-	Analog VDD (3.3V)
106	JITOUT	O	-	For jitter monitor
107	AVDDA	Power	-	Analog VDD (3,3V)
108	TECAPA	I	-	TE signal for CAPA
109	AD0	I	fromFEP	FE input
110	AD2	I	fromFEP	AS input
111	AD1	I	fromFEP	TEph/TE3b/TEpp input
112	AD3	I	fromFEP	RF envelope input
113	AD4	I	fromFEP	RFDIF input
114	AD5	I	fromFEP	CAPA envelope input/hold capacitor

Pin No	Pin name	I/O	Connect to	Description
115	AD6	I	fromFEP	CAPA envelope input/hold capacitor
116	AD7	I	fromFEP	TE signal+
117	AD8	I	fromFEP	TE signal-
118	AVSSA	GND	-	Analog VSS
119	PWM1	O	toDRVIC	Focus drive output
120	PWM2	O	toDRVIC	Tracking drive output
121	VSS	GND	-	VSS
122	VDD3	Power	-	VDD (3.3V)
123	IDGT	O	toFEP	CAPA change signal
124	DTRD	O	toFEP	Data part freq. control change signal
125	MONI0/P9	I/O		Internal monitor signal/General port
126	MONI1/P10	I/O		Internal monitor signal/General port
127	MONI2/P11	I/O		Internal monitor signal/General port
128	MONI3/P12	I/O		Internal monitor signal/General port
129	MSTPOL/MONI4	I/O	-	MASTER pin's polarity setting/internal monitor signal
130	DASPST/MONI5	I/O	-	DASPST setting/Internal monitor signal
131	NEJECT/MONI6	I/O	-	External interrupt/Internal monitor signal
132	NTRYCL/MONI7	I/O	-	External interrupt/Internal monitor signal
133	DMARQ	O	toHOST	ATAPI, DMA request to Host
134	NIOWR	I/O	toHOST	ATAPI, Host write signal input
135	VDD3	Power	-	VDD (3.3V)
136	VSS	GND	-	VSS
137	NIORD	I/O	toHOST	ATAPI host read signal input
138	IORDY	O	toHOST	ATAPI ready out to Host
139	NDMACK	I	toHOST	ATAPI, Host DMA acknowledge
140	INTRQ	O	toHOST	ATAPI, interrupt out to Host
141	NIOCS16	O	toHOST	ATAPI, data bus width select output
142	DA1	I/O	toHOST	ATAPI, Host address signal input
143	NPDIAG	I/O	toHOST	ATAPI, Diagnostic for slave to master.
144	DA0	I/O	toHOST	ATAPI, Host address signal input
145	VSS	GND	-	VSS
146	VDD3	Power	-	VDD (3.3V)
147	DA2	I/O	toHOST	ATAPI, Host address signal input
148	NCS1FX	I	toHOST	ATAPI, Host chip select signal input
149	NCS3FX	I	toHOST	ATAPI, Host chip select signal input
150	NDASP	I/O	toHOST	ATAPI drive active / slave
151	HDD15	I/O	toHOST	ATAPI data output
152	HDD0	I/O	toHOST	ATAPI data output

Pin No	Pin name	I/O	Connect to	Description
153	HDD14	I/O	toHOST	ATAPI data output
154	HDD1	I/O	toHOST	ATAPI data output
155	HDD13	I/O	toHOST	ATAPI data output
156	VDD3	Power	-	VDD (3.3V)
157	VDD15	Power	-	VDD (1.5V)
158	VSS	GND	-	VSS
159	HDD2	I/O	toHOST	ATAPI data output
160	HDD12	I/O	toHOST	ATAPI data output
161	HDD3	I/O	toHOST	ATAPI data output
162	HDD11	I/O	toHOST	ATAPI data output
163	HDD4	I/O	toHOST	ATAPI data output
164	HDD10	I/O	toHOST	ATAPI data output
165	HDD5	I/O	toHOST	ATAPI data output
166	VSS	GND	-	VSS
167	VDD3	Power	-	VDD (3.3V)
168	HDD9	I/O	toHOST	ATAPI data output
169	HDD6	I/O	toHOST	ATAPI data output
170	HDD8	I/O	toHOST	ATAPI data output
171	HDD7	I/O	toHOST	ATAPI data output
172	VDDH	Power	-	5V, Reference
173	NRESET	I	toHOST	ATAPI, reset signal input
174	MASTER	I	toHOST	ATAPI, Master/Slave signal input
175	P0/SERIAL	I/O		General purpose port
176	P1/SERIAL	I/O		General purpose port

# IC301 (M63028FP): Drive IC

## Block Diagram

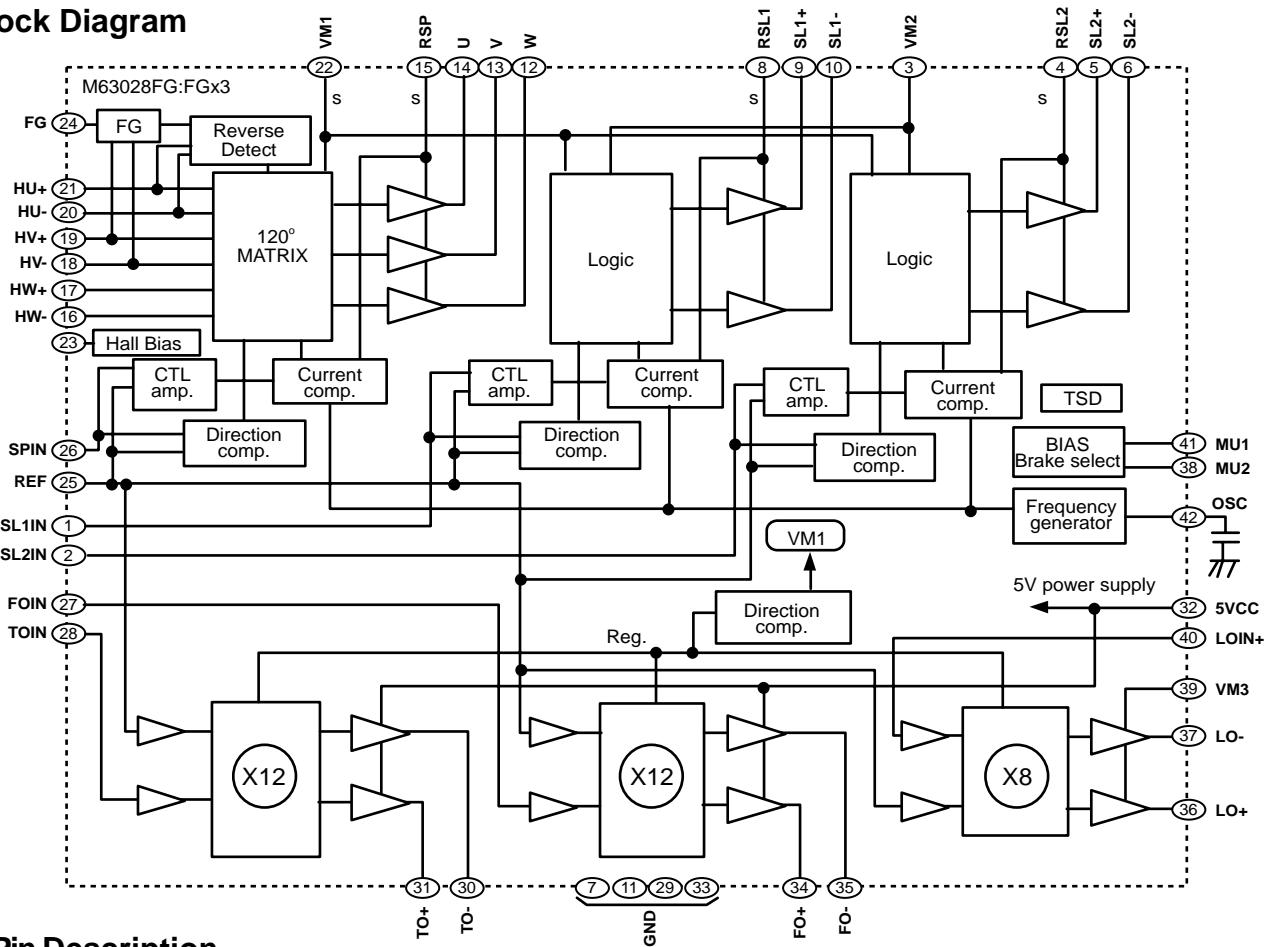

## • Pin Description

Terminal	SYMBOL	TERMINAL FUNCTION	Terminal	SYMBOL	TERMINAL FUNCTION
1	SL1IN	Slide control voltage input 1.	22	VM1	Motor power Supply 1(for Spindle)
2	SL2IN	Slide control voltage input 2.	23	HB	Bias for Hall Sensor
3	VM2	Motor Power Supply 2(for Slide)	24	FG	Frequency generator output
4	RSL2	Slide current sense 2.	25	REF	Reference voltage input
5	SL2+	Slide non-inverted output 2	26	SPIN	Spindle control voltage input
6	SL2-	Slide inverted output 2	27	FOIN	Focus control voltage input
7	GND	GND	28	TOIN	Tracking control voltage input
8	RSL1	Slide current sense 1	29	GND	GND
9	SL1+	Slide non-inverted output 1	30	TO-	Tracking inverted output
10	SL1-	Slide inverted output 1	31	TO+	Tracking non-inverted output
11	GND	GND	32	5VCC	5V Power Supply (for FS, TS)
12	W	Motor drive output W	33	GND	GND
13	V	Motor drive output V	34	FO+	Focus non-inverted output
14	U	Motor drive output U	35	FO-	Focus inverted output
15	RSP	Spindle current sense	36	LO+	Loading non-inverted output
16	HW-	HW- sensor amp. input	37	LO-	Loading inverted output
17	HW+	HW+ sensor amp. input	38	MU2	Mute/Brake select terminal 2
18	HV-	HV- sensor amp. input	39	VM3	Power supply 3 (for Loading)
19	HV+	HV+ sensor amp. input	40	LOIN+	Loading control input (+)
20	HU-	HU- sensor amp. input	41	MU1	Mute /Brake select terminal 1
21	HU+	HU+ sensor amp. input	42	OSC	PWM carrier oscillation set

# TROUBLESHOOTING GUIDE

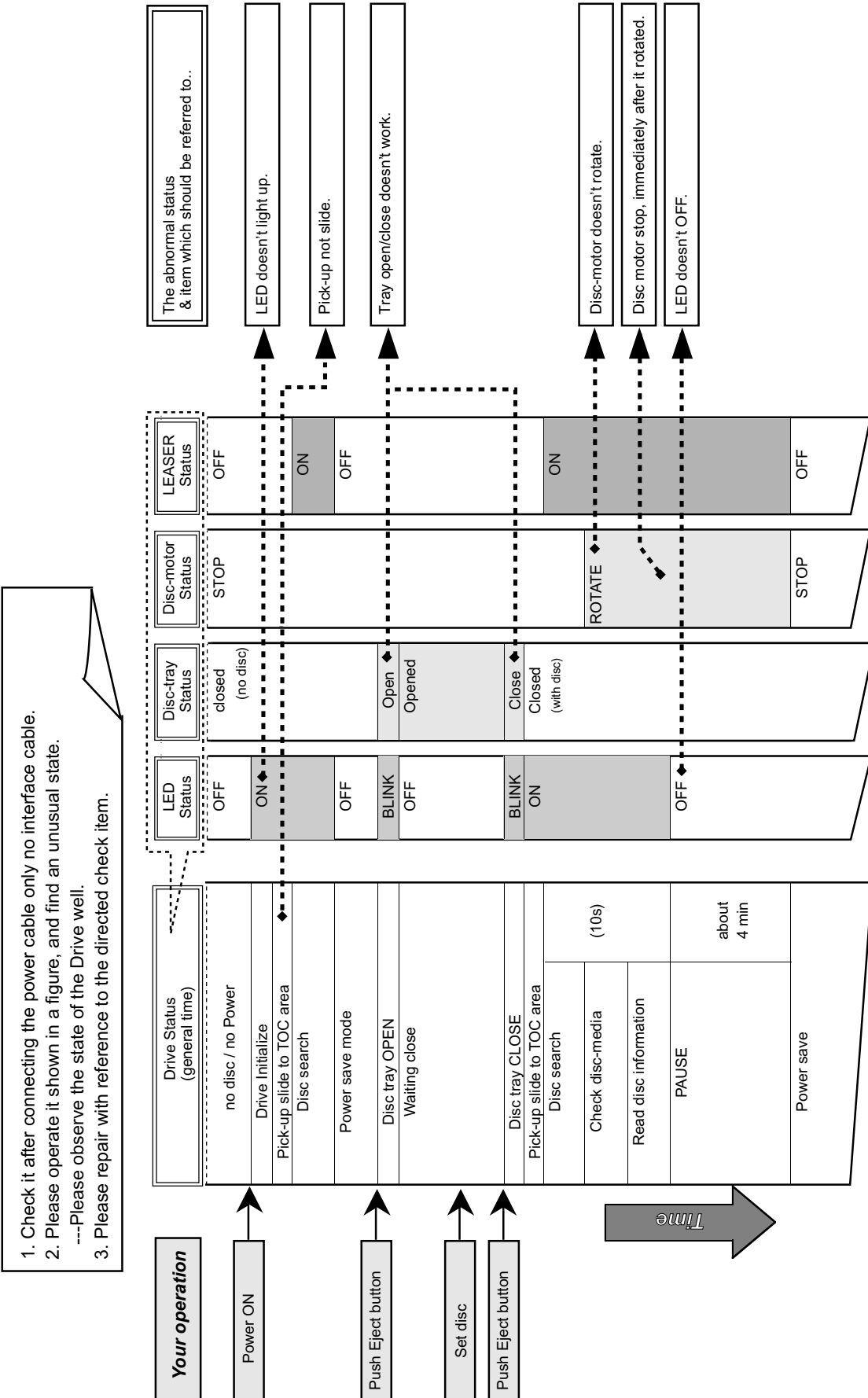

**LED doesn't light up**

Note : When circuit number is written, check parts and soldering including a nearby circuit.  
When two or more pin numbers are indicated by the party, check signal-line including a nearby circuit.

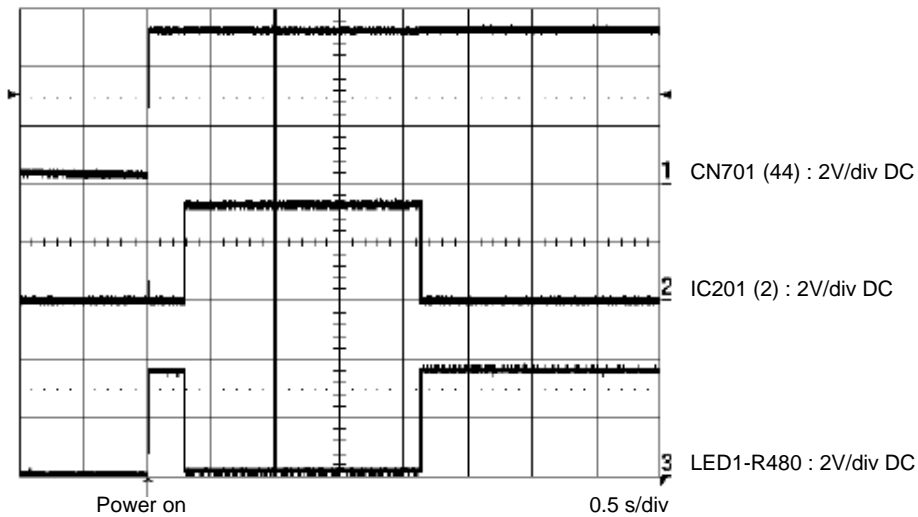
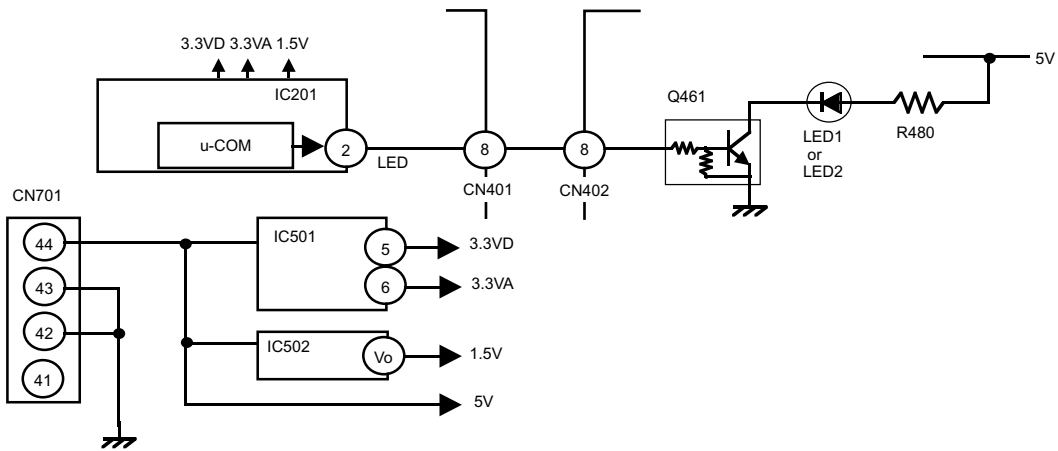
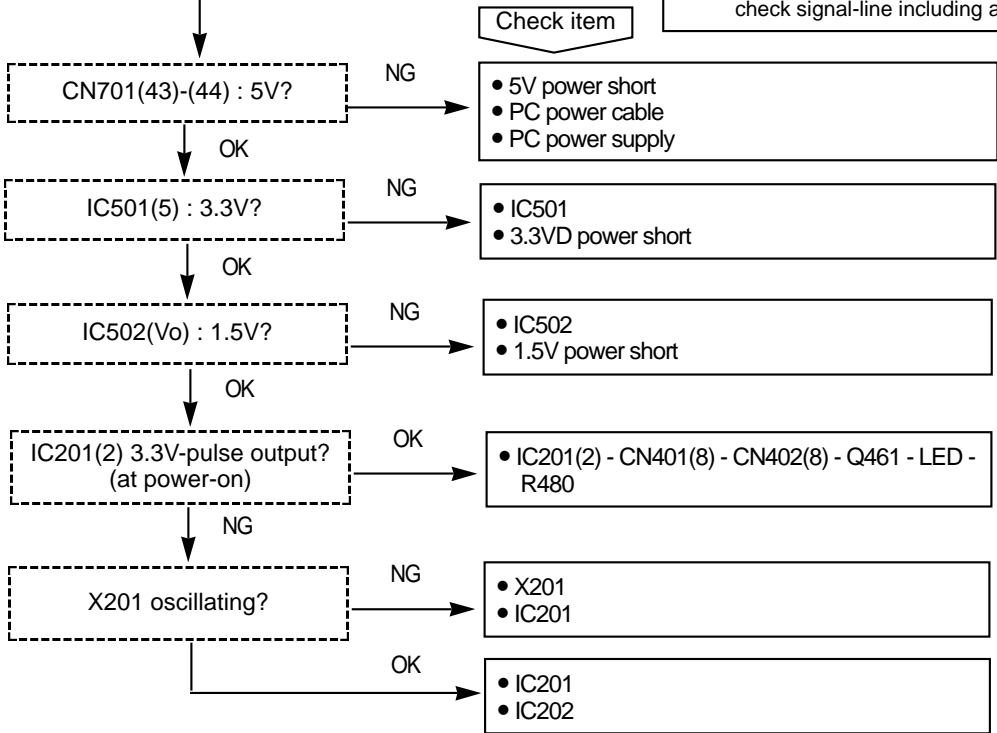



(When a power supply is switched on)  
**Pick-up not slide**

Note : Pick-up unit slide, when Power ON(or drive reset) or disc tray closed.  
 Pick-up slide to TOC area of disc, after going to the maximum inner side.  
 The distance between the maximum inner side and TOC area of disc is about 3mm.

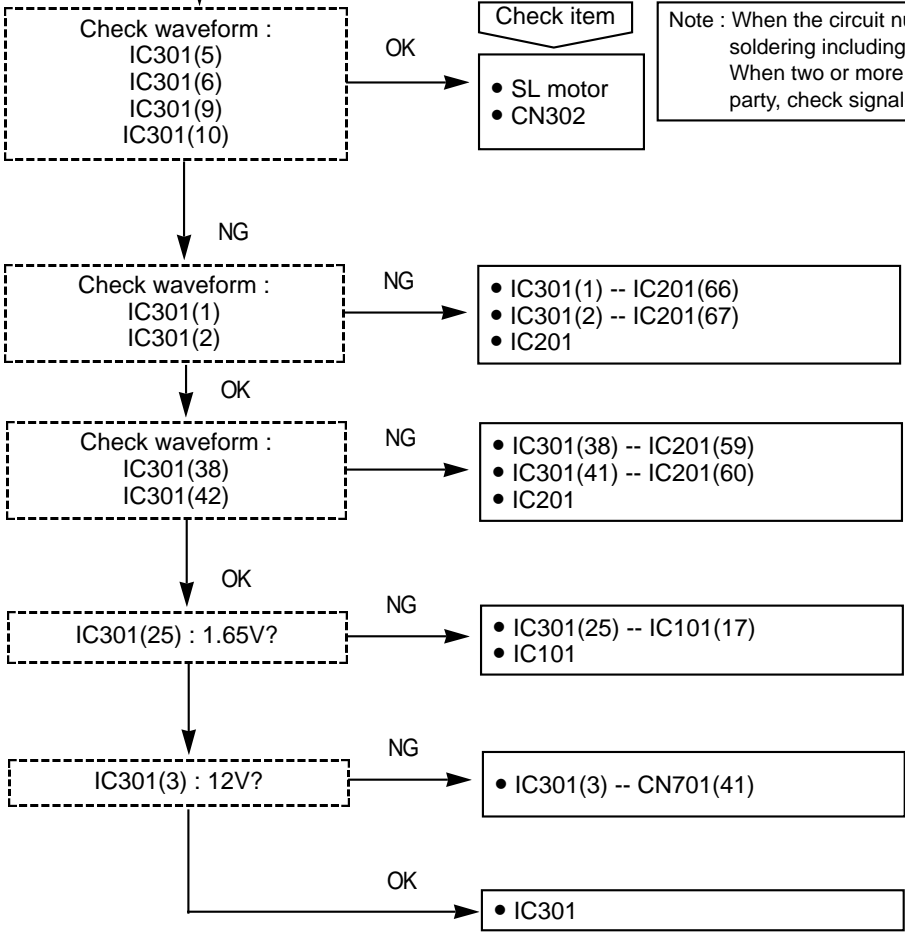

Note : When the circuit number is written, check parts and soldering including a nearby circuit.  
 When two or more pin numbers are indicated by the party, check signal-line including a nearby circuit.

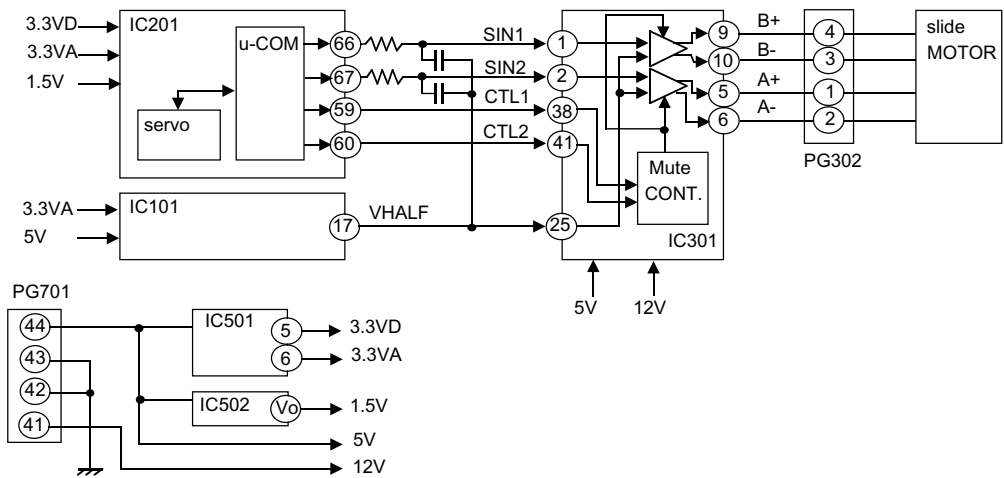

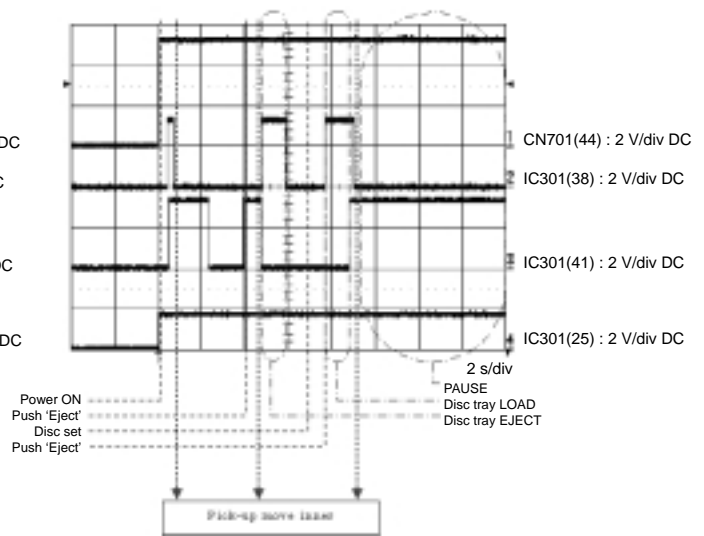
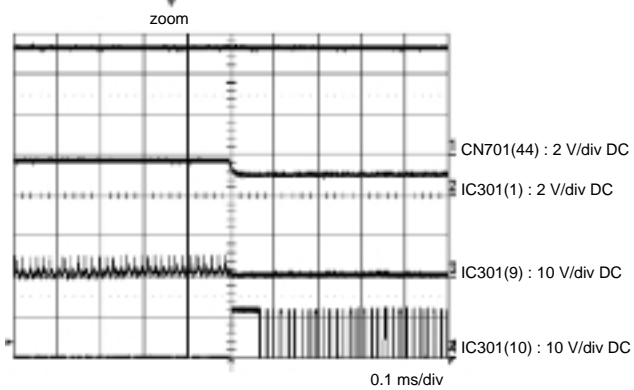
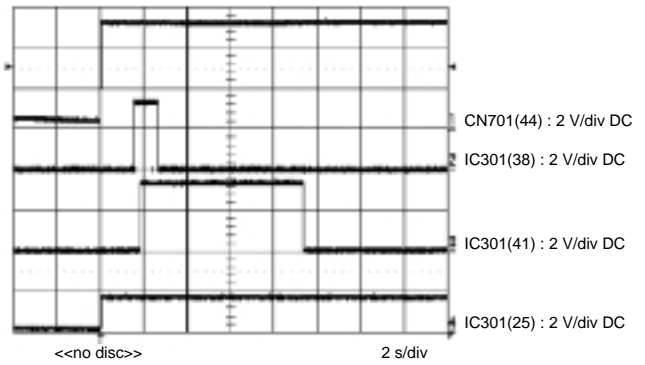
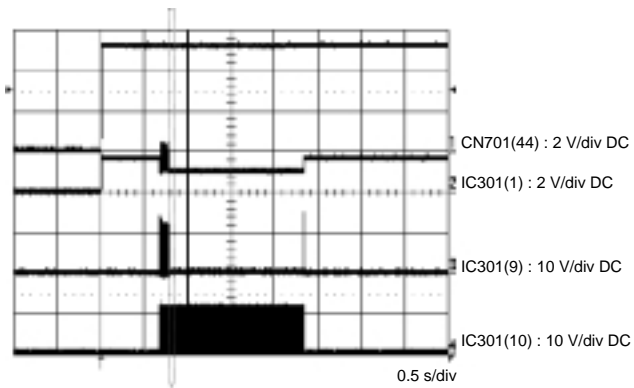

# Reference information of slide motor control

**REF-0**

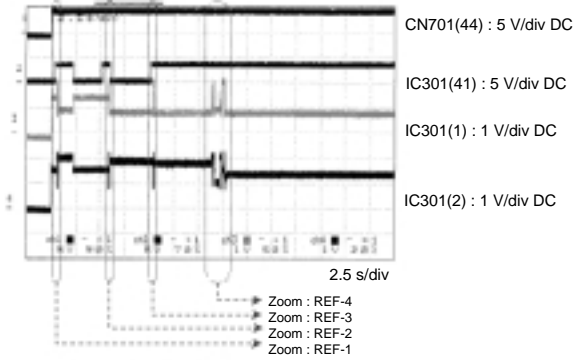

**REF-1**

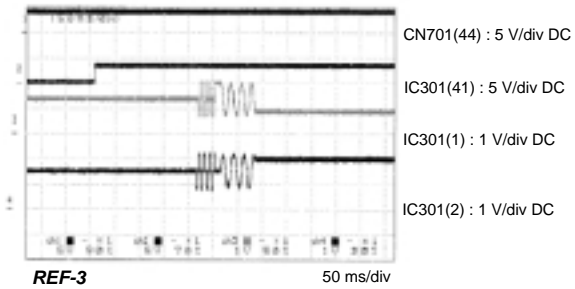

**REF-3**

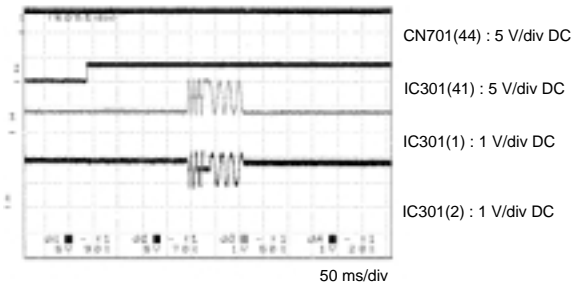

**REF-5**

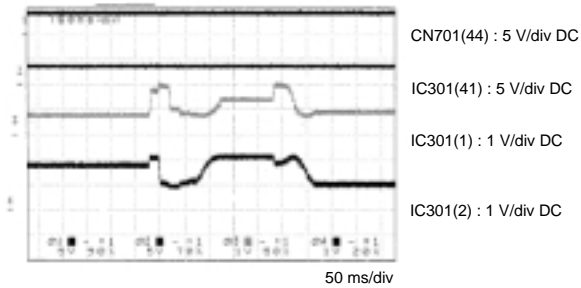

**REF-7**

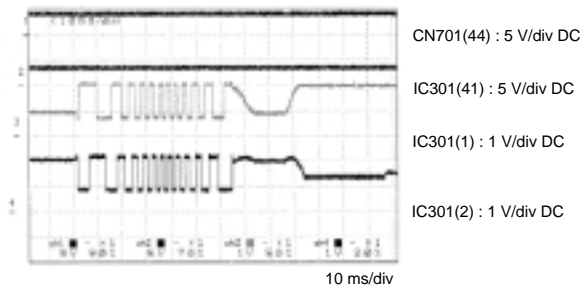

**REF-2**

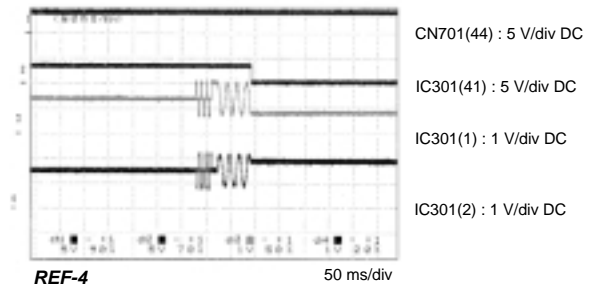

**REF-4**

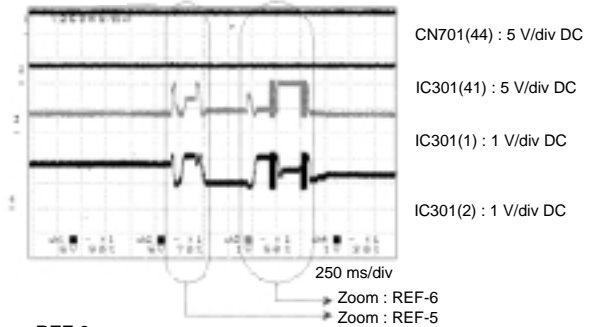

**REF-6**

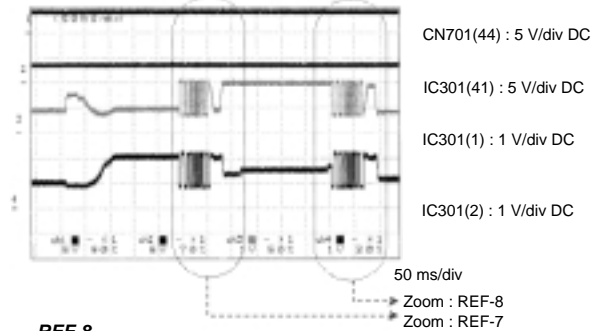

**REF-8**

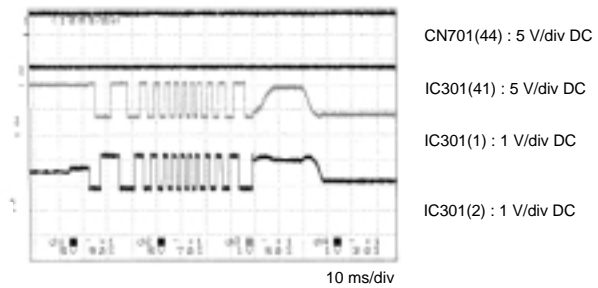

**Tray open/close doesn't work**

Note : When the circuit number is written, check parts and soldering including a nearby circuit.  
When two or more pin numbers are indicated by the party, check signal-line including a nearby circuit.

Check item

Push SW701 then,  
IC201 (131) : Low (0V)?

NG

- SW701
- SW701 - CN402(1) - CN402(1) - IC201(131)

OK

Push SW401 then,  
IC201 (132) or (176) : Low(0V)?

NG

- SW401
- SW401 - CN402(9) - CN401(9) - IC201(132)
- SW401 - CN402(10) - CN401(10) - IC201(176)

OK

Check wave form:  
IC301(38)  
IC301(41)  
IC301(40)

NG

- IC301(38) -- IC201(59)
- IC301(41) -- IC201(60)
- IC301(40) -- IC201(65)
- IC201

OK

IC301(25) : 1.65V?

NG

- IC101(17) -- IC301(25)
- IC101

OK

Check wave form:  
IC301(36)  
IC301(37)

NG

- IC301

OK

Check wave form:  
TM403(1)-(2) or CN402(11)-(12)

NG

- IC301(36) - CN401(11) - CN402(11) - CN402(12)
- IC301(37) - CN401(12) - CN402(12) - CN402(11)

OK

Can Disc tray be moved by hand?

NG

- Loading mecha.

OK

- Loading motor.

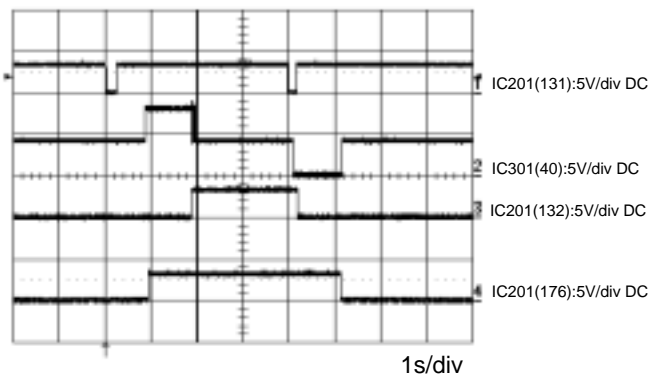
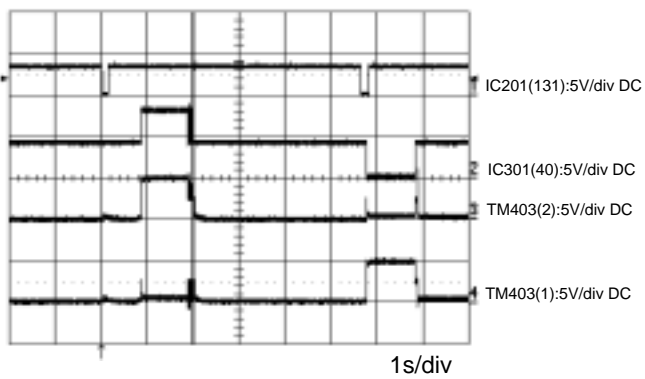
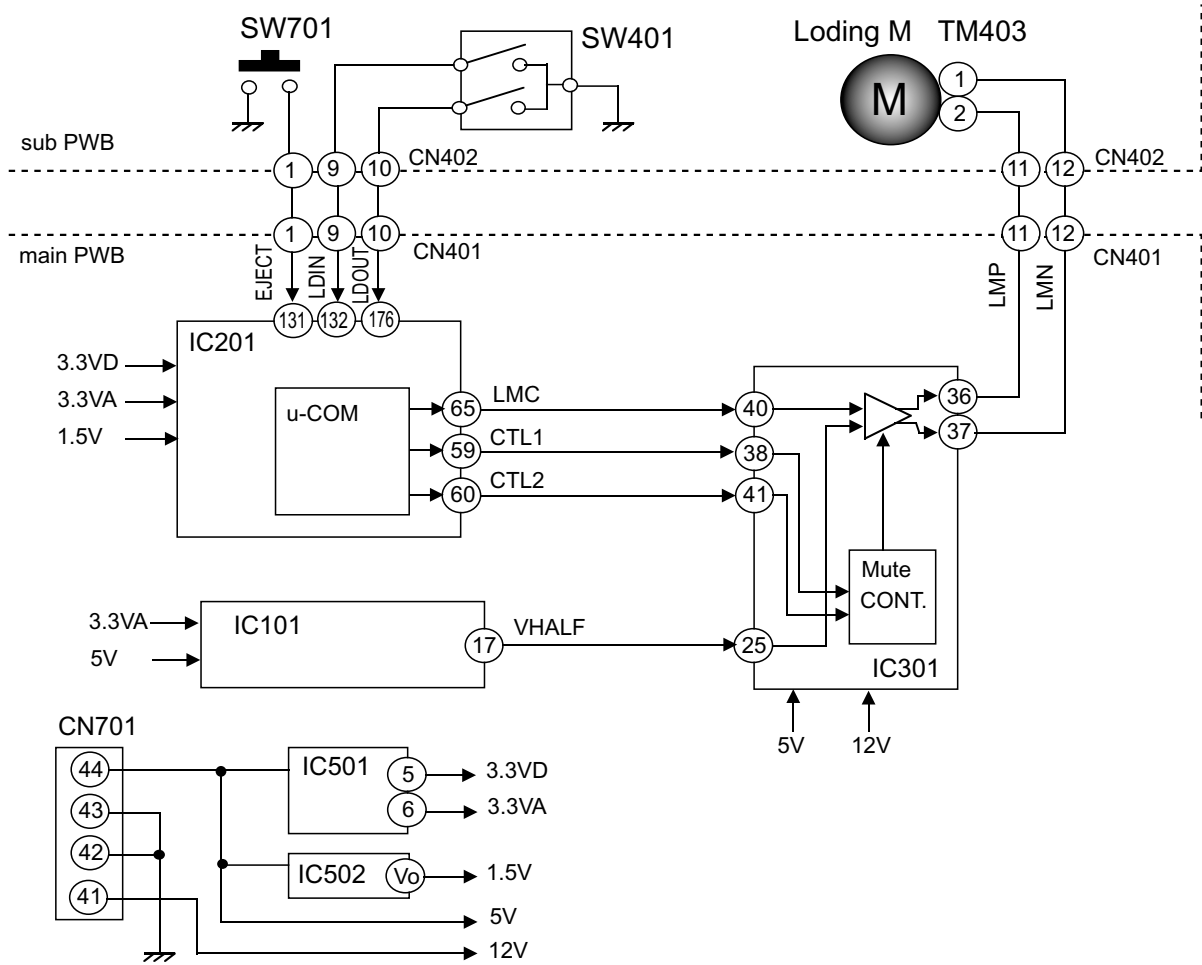

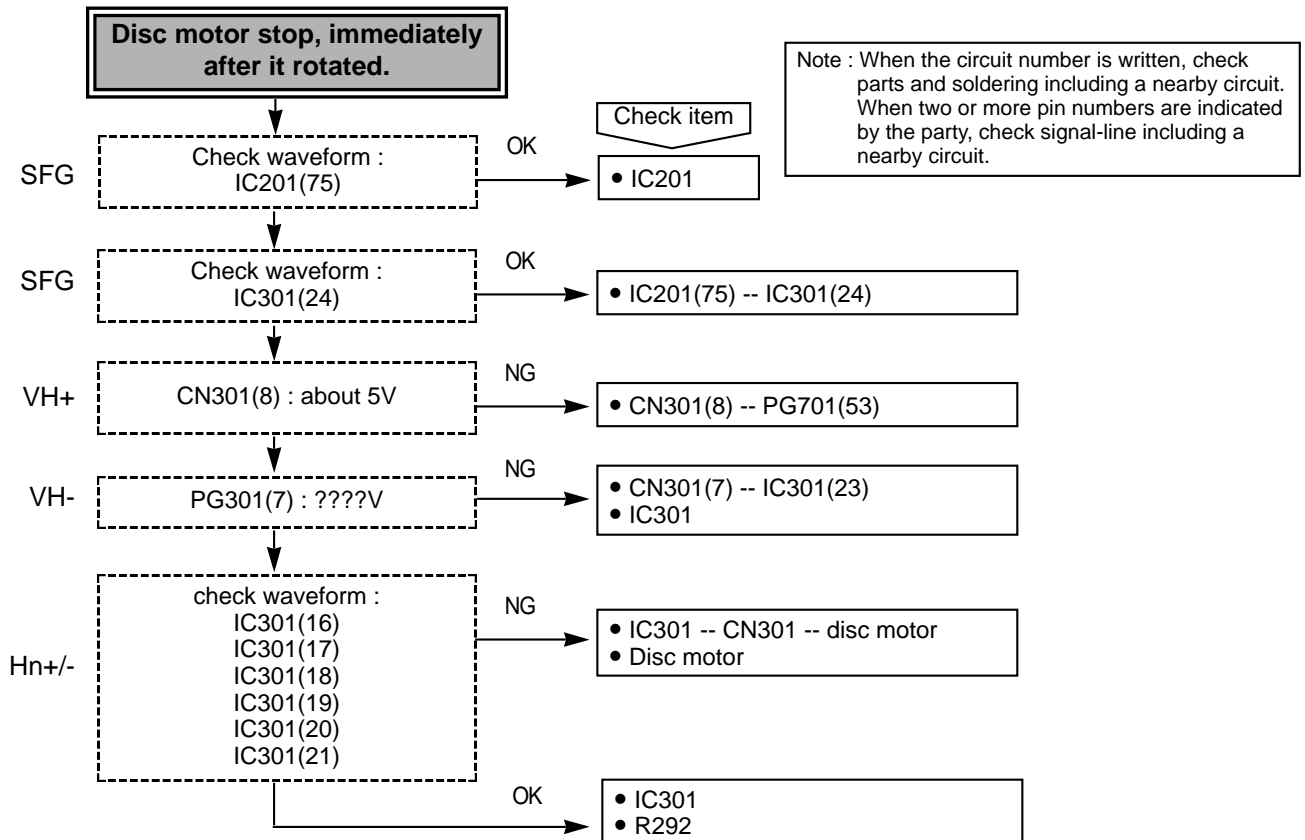
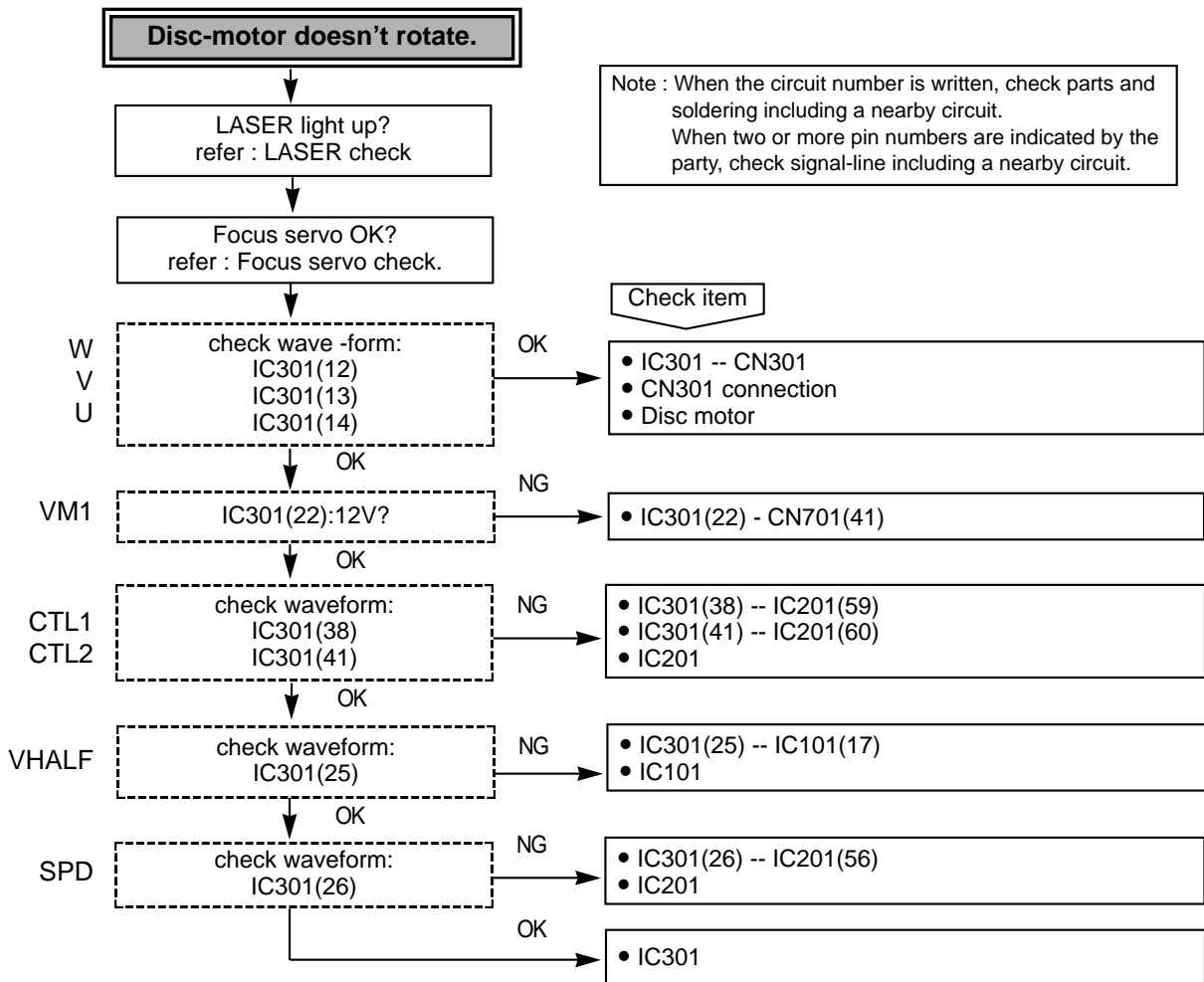

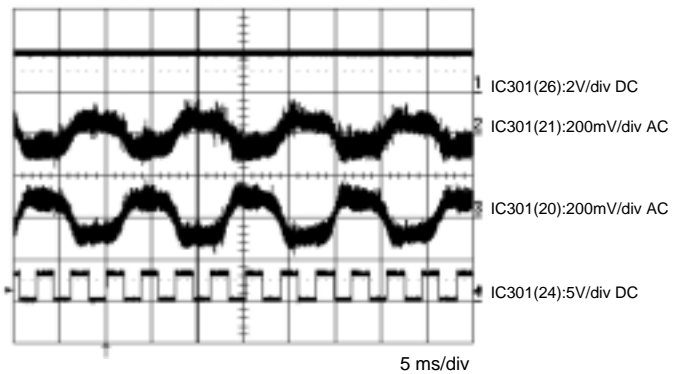
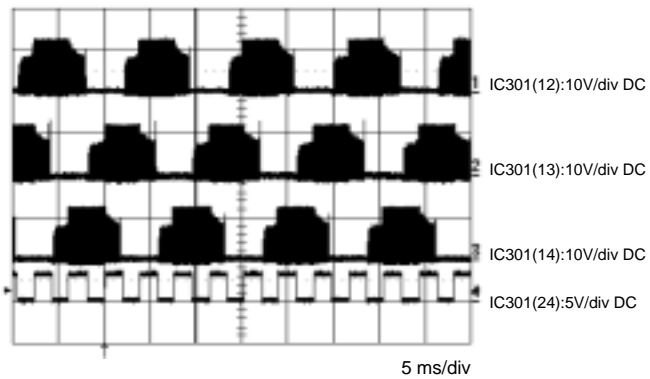
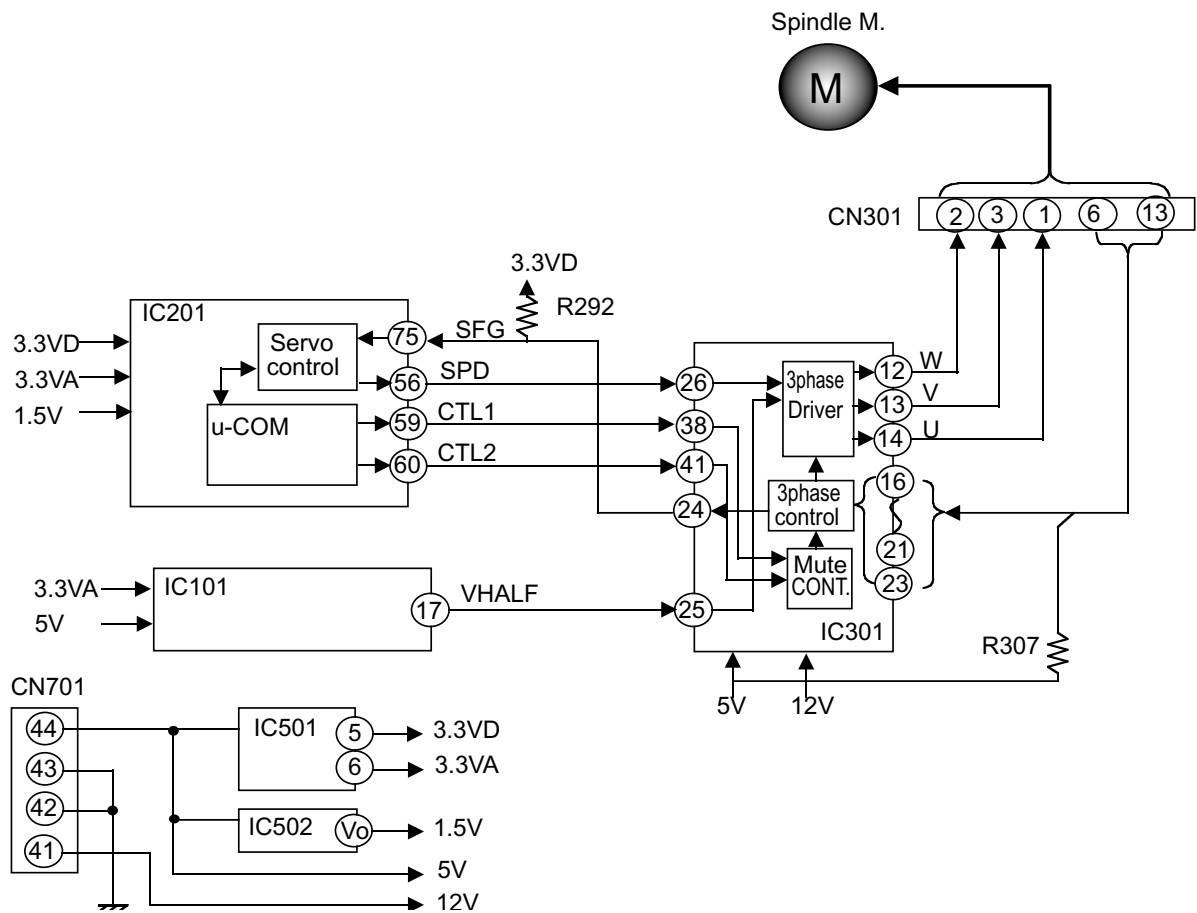

**LED doesn't OFF**

Note : When the circuit number is written, check parts and soldering including a nearby circuit.  
When two or more pin numbers are indicated by the party, check signal-line including a nearby circuit.

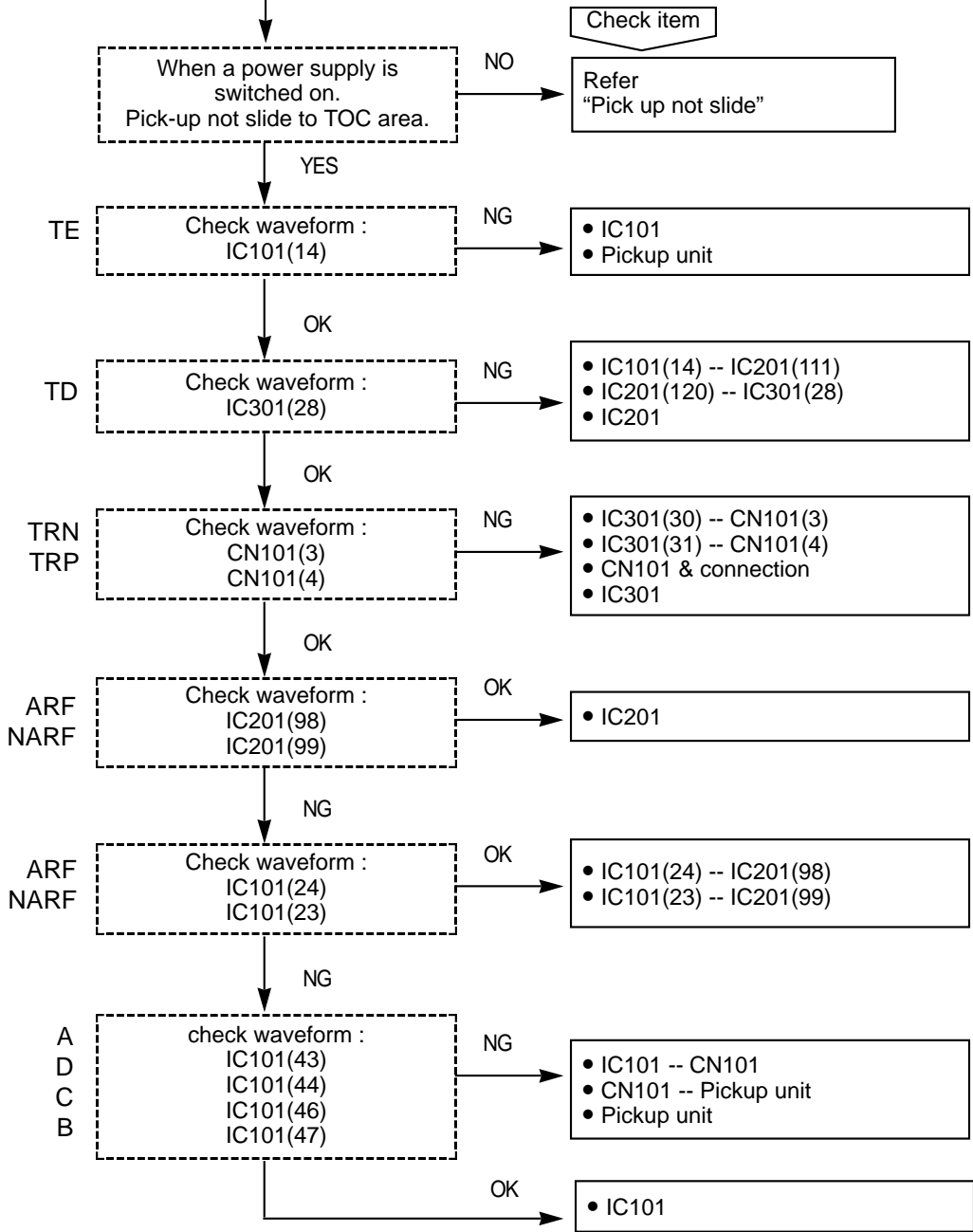



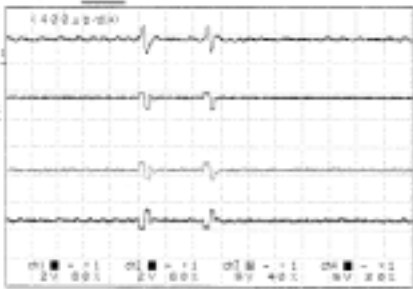
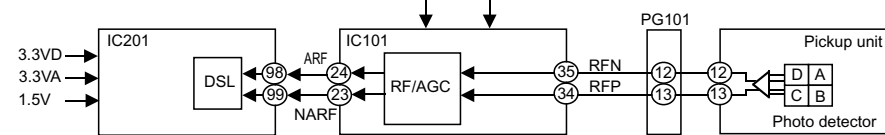
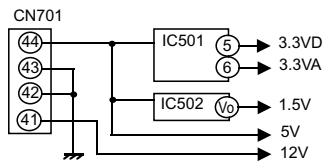
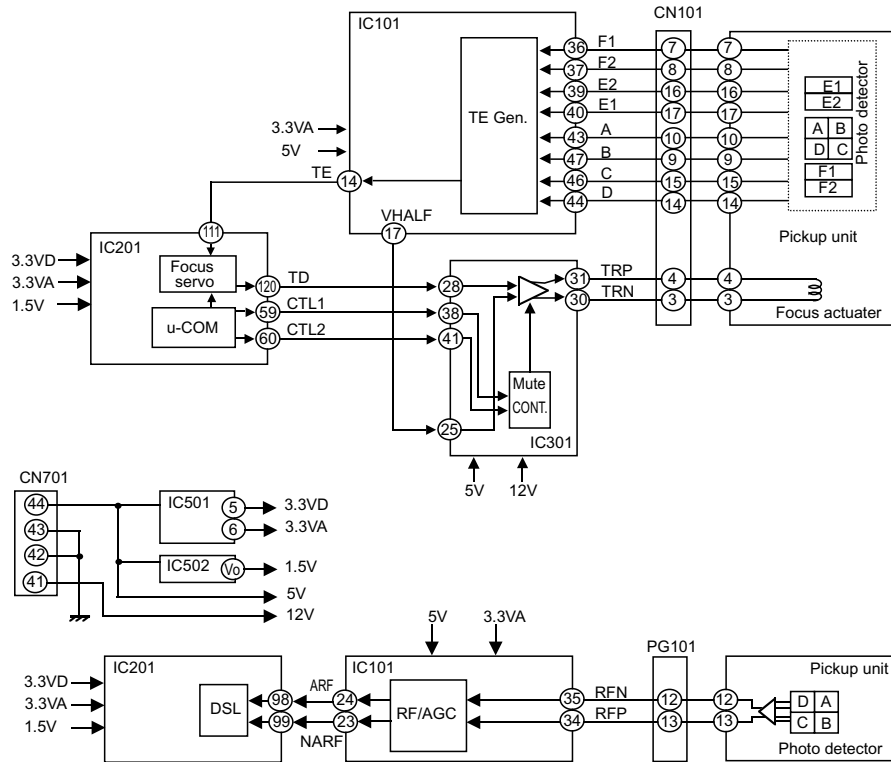

IC101(14) : 2 V/div DC  
 IC301(28) : 2 V/div DC  
 IC301(31) : 5 V/div DC  
 IC301(30) : 5 V/div DC

400 us/div

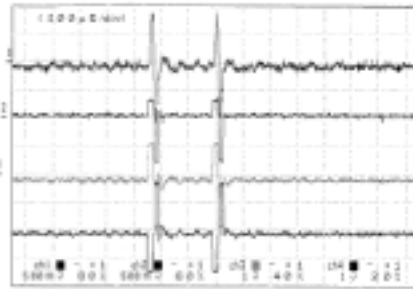

IC101(14) : 500 mV/div AC  
 IC301(28) : 500 mV/div AC  
 IC301(31) : 1 V/div AC  
 IC301(30) : 1 V/div AC

400 us/div

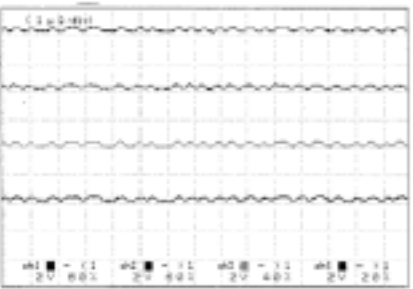

IC101(43) : 2 V/div DC  
 IC101(47) : 2 V/div DC  
 IC101(46) : 5 V/div DC  
 IC101(44) : 5 V/div DC

1 us/div

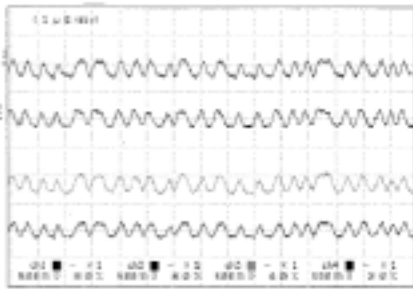

IC101(43) : 500 mV/div AC  
 IC101(47) : 500 mV/div AC  
 IC101(46) : 500 mV/div AC  
 IC101(44) : 500 mV/div AC

1 us/div

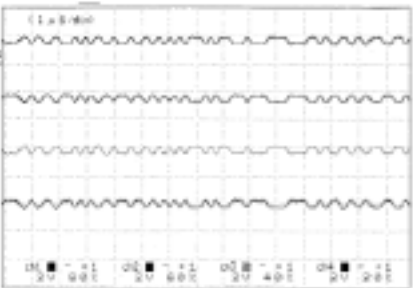

IC101(34) : 2 V/div DC  
 IC101(35) : 2 V/div DC  
 IC201(98) : 2 V/div DC  
 IC201(99) : 2 V/div DC

1 us/div

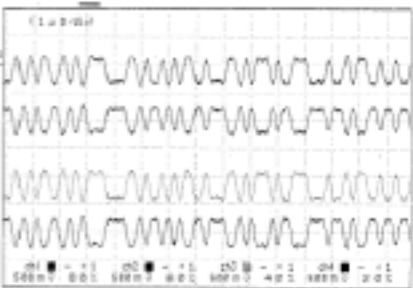

IC101(34) : 500 mV/div AC  
 IC101(35) : 500 mV/div AC  
 IC201(98) : 500 mV/div AC  
 IC201(99) : 500 mV/div AC

1 us/div

# LASER check.

**Caution : Don't see LASER for your eyes!!**

Note : When the circuit number is written, check parts and soldering including a nearby circuit.  
When two or more pin numbers are indicated by the party, check signal-line including a nearby circuit.

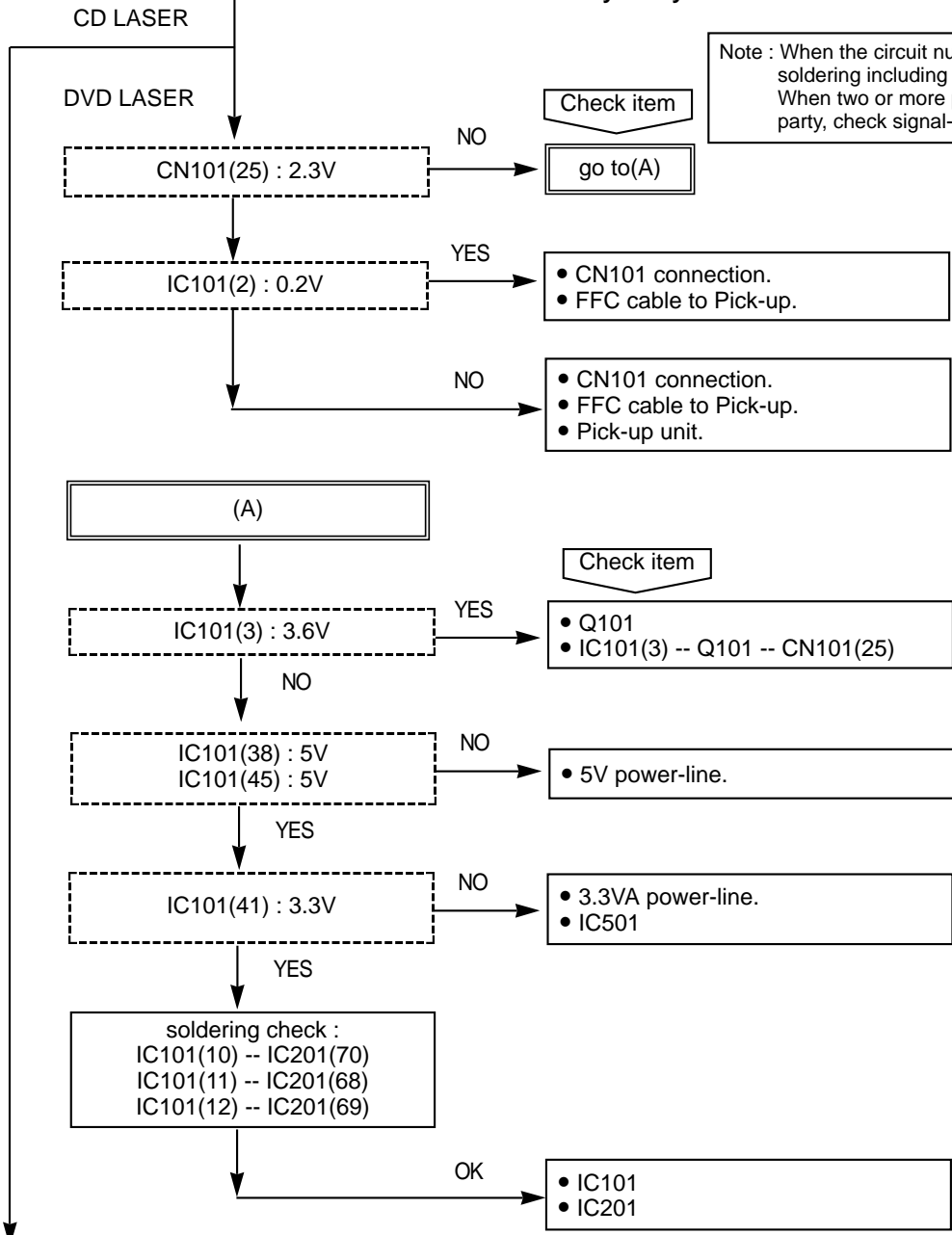

CD LASER

CN101(21) : 2.3V

CN101(3) : 0.2V

Note : When the circuit number is written, check parts and soldering including a nearby circuit.  
When two or more pin numbers are indicated by the party, check signal-line including a nearby circuit.

Check item

go to(B)

- CN101 connection.
- FFC cable to Pick-up.

- CN101 connection.
- FFC cable to Pick-up.
- Pick-up unit.

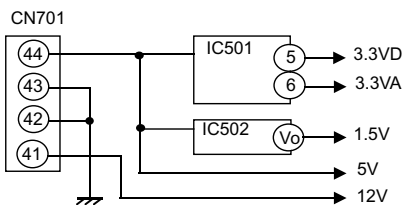
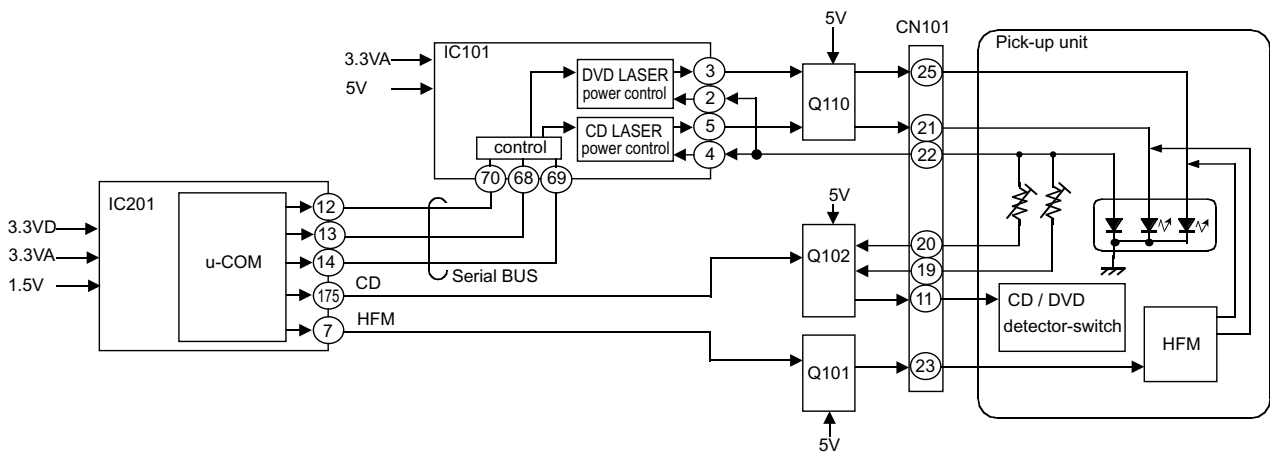
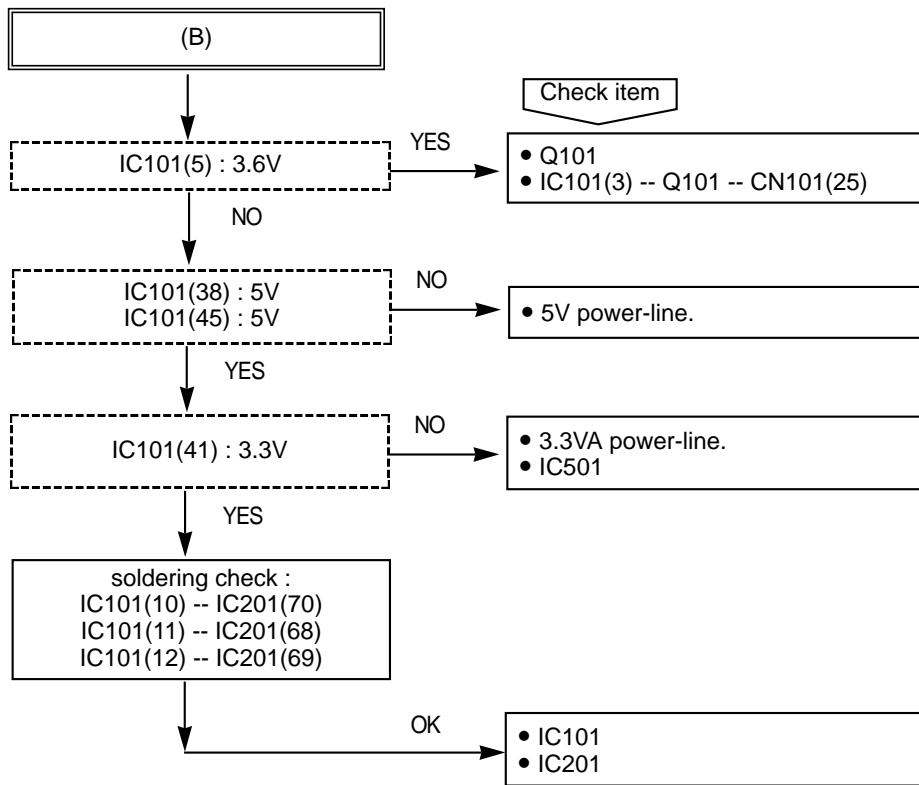

# Focus servo check

After the LASER check, do this check item!

Note : When the circuit number is written, check parts and soldering including a nearby circuit.  
When two or more pin numbers are indicated by the party, check signal-line including a nearby circuit.

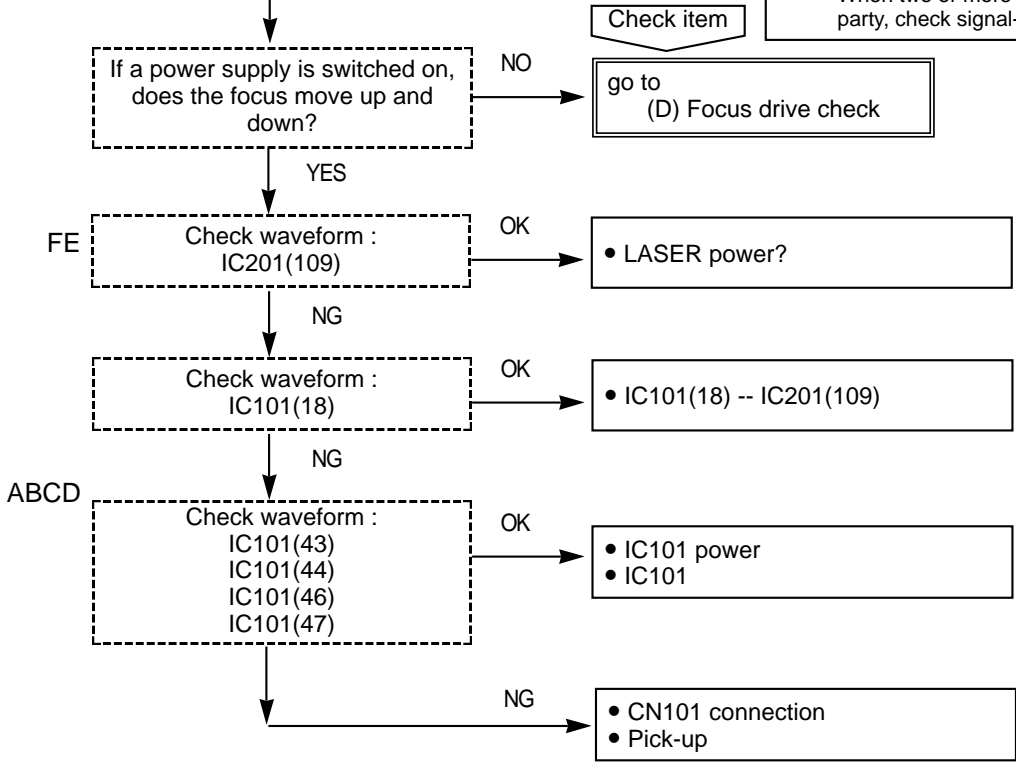

# (D) Focus drive check

Check item

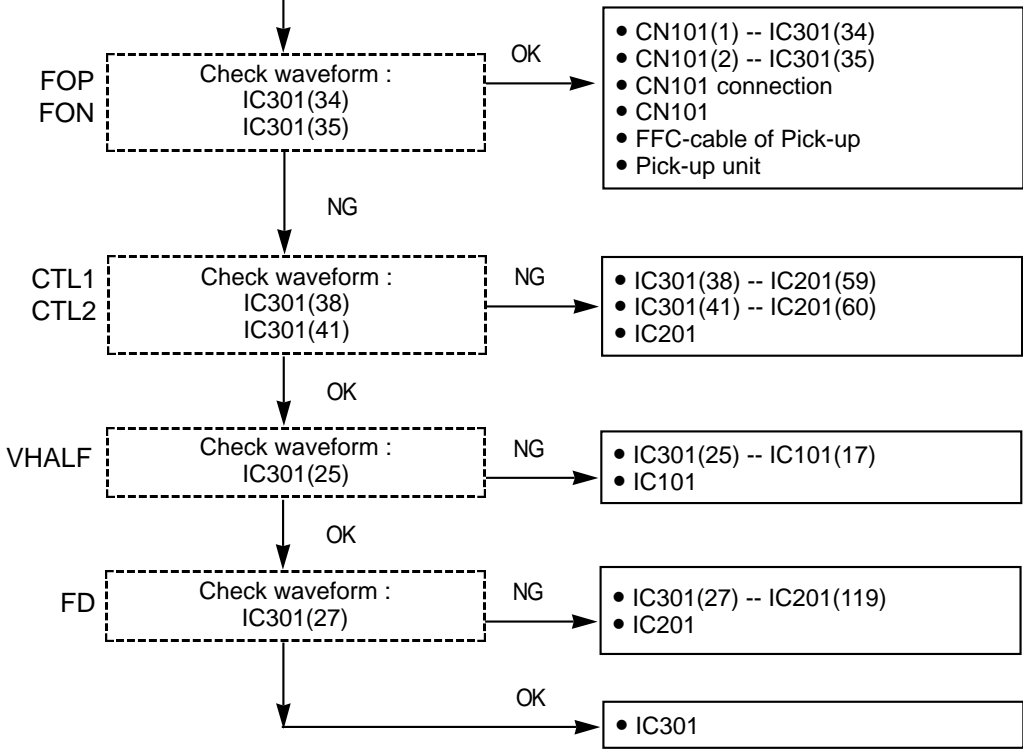

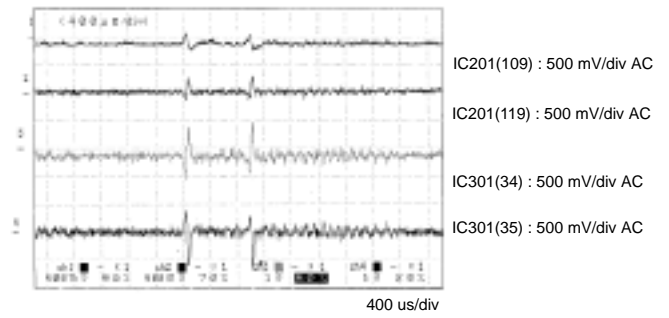
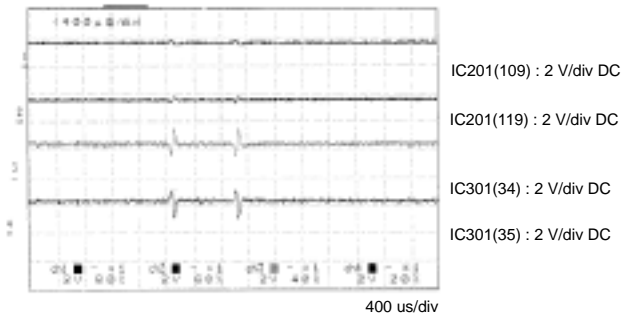
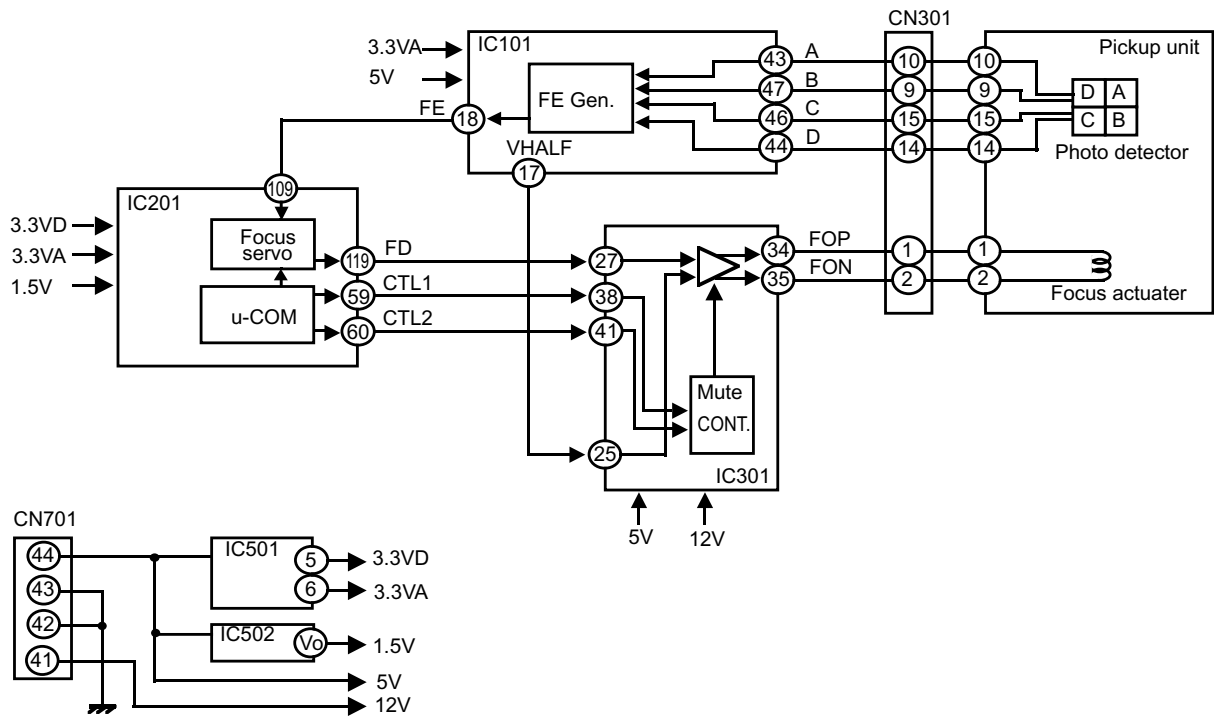

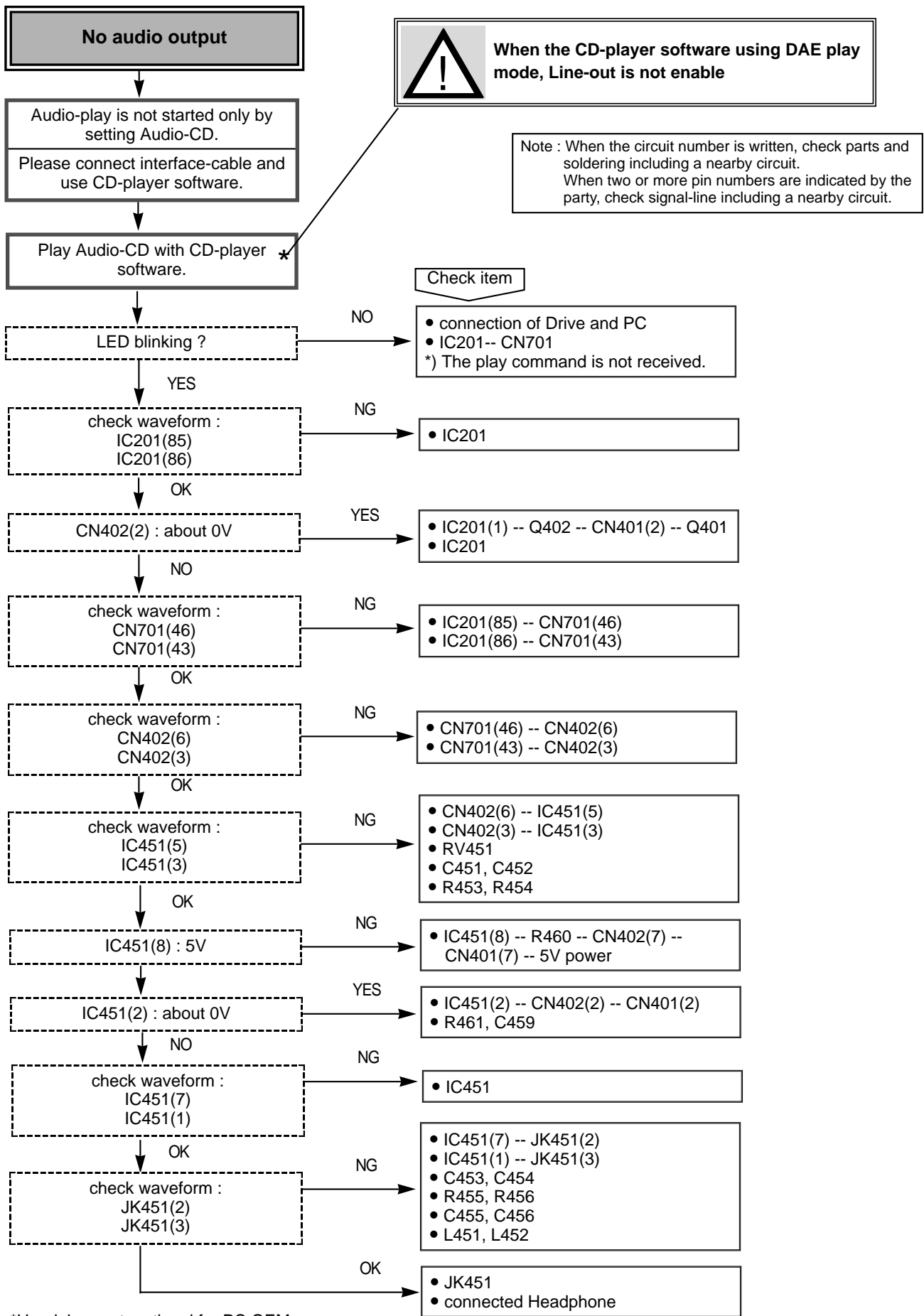

# BLOCK DIAGRAM

