



# HIGH SPEED NPN POWER DARLINGTON TRANSISTORS

**GE5060,1,2**

**400-500 VOLTS  
20 AMP, 125 WATTS**

These devices are designed for use in high speed switching applications, such as off-line switching power supplies, AC & DC motor control, UPS systems, ultrasonic equipment and other high frequency power conversion equipment.

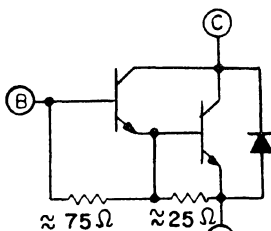

**DEVICE CIRCUIT**

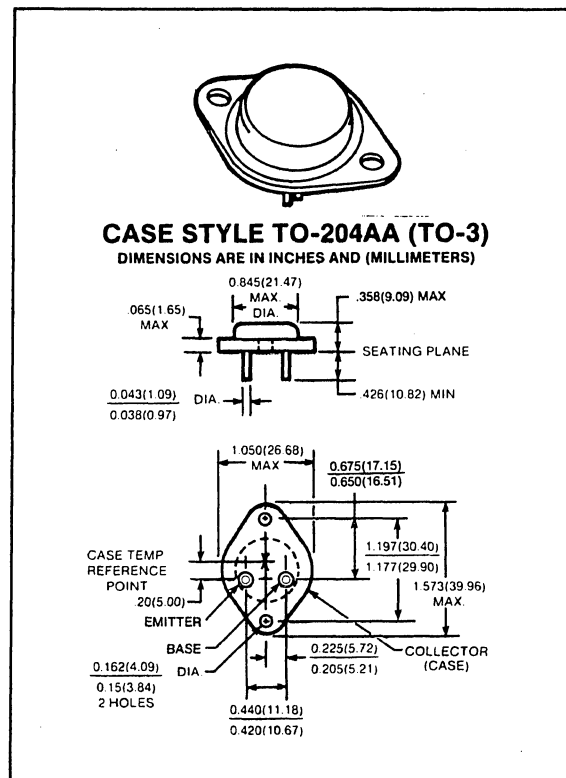

maximum ratings ( $T_C = 25^\circ C$ ) (unless otherwise noted)

RATING	SYMBOL	GE5060	GE5061	GE5062	UNITS
Collector-Base Voltage	$V_{CBO}$	400	450	500	Volts
Collector-Emitter Voltage	$V_{CEO}$	350	400	450	Volts
Emitter Base Voltage	$V_{EBO}$	8	8	8	Volts
Collector Current — Continuous	$I_C$	20	20	20	A
Peak (Repetitive)	$I_{CM}$	25	25	25	
Peak (Non-Repetitive)	$I_{CSM}$	42.5	42.5	42.5	
Base Current — Continuous	$I_B$	4	4	4	A
Peak (Non-Repetitive)	$I_{BM}$	6	6	6	
Total Power Dissipation @ $T_C = 25^\circ C$	$P_D$	125	125	125	Watts
Operating and Storage Junction Temperature Range	$T_J, T_{STG}$	-65 to +150	-65 to +150	-65 to +150	$^\circ C$

## thermal characteristics

Thermal Resistance, Junction to Case	$R_{\theta JC}$	1	1	1	$^\circ C/W$
Maximum Lead Temperature for Soldering Purposes: $\frac{1}{8}$ " from Case for 5 Seconds	$T_L$	300	300	300	$^\circ C$

electrical characteristics ( $T_C = 25^\circ\text{C}$ ) (unless otherwise specified)

CHARACTERISTIC	SYMBOL	MIN	TYP	MAX	UNIT
----------------	--------	-----	-----	-----	------

### off characteristics<sup>(1)</sup>

Collector-Emitter Sustaining Voltage ( $I_C = .5\text{mA}$ ) ( $V_{\text{clamp}} = V_{\text{CEO Rated}}$ )	GE5060 GE5061 GE5062	$V_{\text{CEO(sus)}}$	350 400 450	— — —	— — —	Volts
Collector-Base Voltage ( $I_C = 0.25\text{mA}$ )	GE5060 GE5061 GE5062	$V_{\text{CBO}}$	400 450 500	— — —	— — —	Volts
Collector Cutoff Current ( $V_{\text{CB}} = V_{\text{CBO Rated}}$ )		$I_{\text{CBO}}$	—	—	.25	mA
Emitter Cutoff Current ( $V_{\text{EB}} = 4.5\text{V}$ , $I_C = 0$ )		$I_{\text{EBO}}$	—	—	200	mA

### second breakdown

Second Breakdown with Base Forward Biased	FBSOA	SEE FIGURE 16
Clamped Inductive soa with Base Reversed Bias	RBSOA	SEE FIGURE 17

### on characteristics

DC Current Gain ( $I_C = 10\text{A}$ , $V_{\text{CE}} = 5\text{V}$ ) ( $I_C = 15\text{A}$ , $V_{\text{CE}} = 5\text{V}$ ) ( $I_C = 20\text{A}$ , $V_{\text{CE}} = 5\text{V}$ )	$h_{\text{FE}}$	100 40 15	160 115 65	— — —	—
Collector-Emitter Saturation Voltage ( $I_C = 10\text{A}$ , $I_B = 1\text{A}$ ) ( $I_C = 10\text{A}$ , $I_B = 2\text{A}$ ) ( $I_C = 20\text{A}$ , $I_B = 2.0\text{A}$ )	$V_{\text{CE(sat)}}$	— — —	1.20 1.15 1.6	1.5 1.4 2.0	V
Base-Emitter Voltage ( $I_C = 10\text{A}$ , $I_B = 1\text{A}$ ) ( $I_C = 20\text{A}$ , $I_B = 2\text{A}$ )	$V_{\text{BE(sat)}}$	— —	1.95 2.3	2.5 3.5	V

### switching characteristics

Resistive Load						
Rise Time	$I_C = 15\text{A}$ , $I_{B1} = .75\text{A}$ , $I_{B2} = 1.5\text{A}$ $V_{\text{CC}} = 300\text{V}$ , $t_p = 50 \mu\text{sec}$	$t_r$	—	0.3	—	$\mu\text{s}$
Storage Time		$t_s$	—	2.7	—	
Fall Time		$t_f$	—	1.15	—	
Inductive Load, Clamped						
Storage Time	$V_{\text{CC}} = 300\text{V}$ , $L = 100 \mu\text{H}$ $I_C = 15\text{A}$ , $I_{B1} = .75\text{A}$ , $I_{B2} = 1.5\text{A}$	$t_s$	—	3.3	—	$\mu\text{s}$
Crossover Time		$t_c$	—	1.7	—	
Fall Time		$t_f$	—	0.4	—	

### emitter-collector diode characteristics

Forward Voltage $I_F = 10\text{A}$ $I_F = 25\text{A}$	$V_F$	— —	1.9 2.8	— —	Volts
---	-------	--------	------------	--------	-------

# TYPICAL CHARACTERISTICS

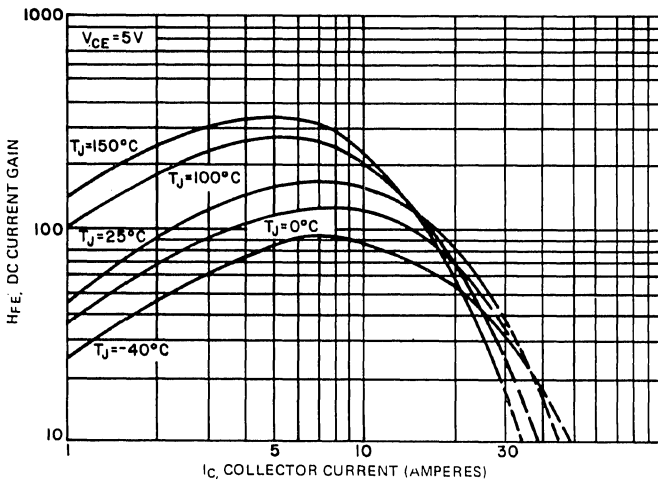

FIGURE 1. DC CURRENT GAIN ( $V_{CE} = 2V$ )

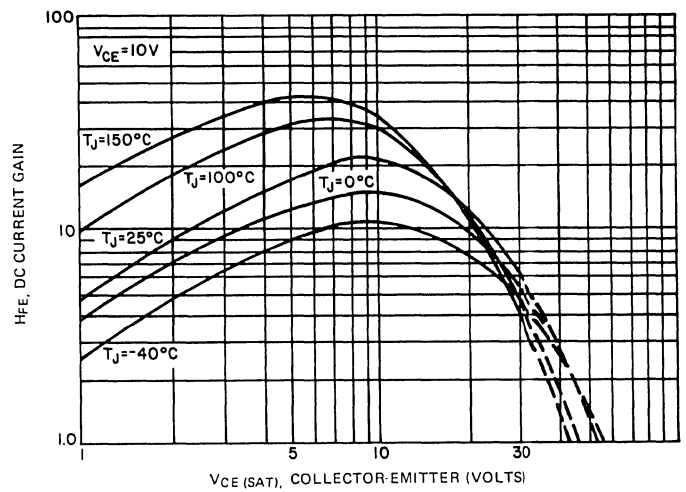

FIGURE 2. DC CURRENT GAIN ( $V_{CE} = 10V$ )

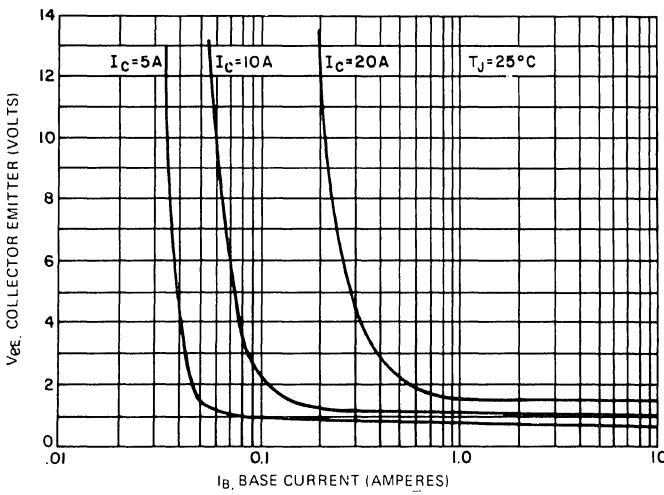

FIGURE 3. COLLECTOR SATURATION REGION

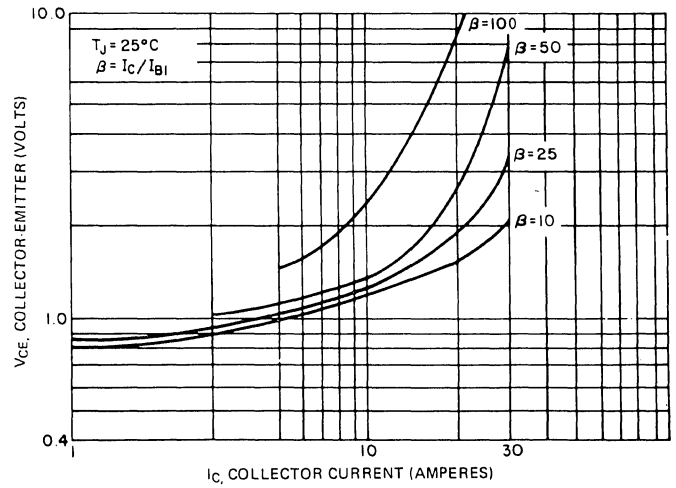

FIGURE 4.  $V_{CE(SAT)}$  VS.  $I_C$ ,  $T_J = 25^\circ C$

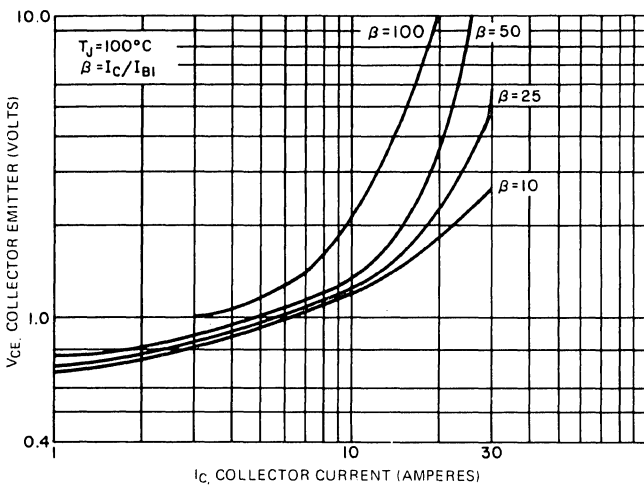

FIGURE 5.  $V_{CE(SAT)}$  VS.  $I_C$ ,  $T_J = 100^\circ C$

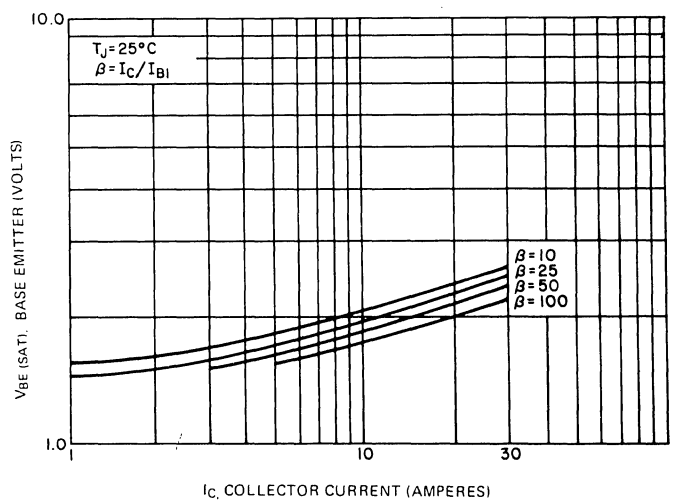

FIGURE 6.  $V_{BE(SAT)}$  VS.  $I_C$ ,  $T_J = 25^\circ C$

# TYPICAL CHARACTERISTICS

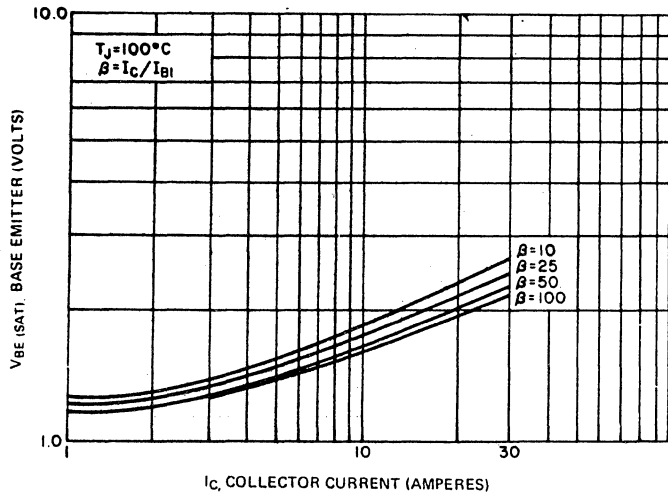

FIGURE 7.  $V_{BE(SAT)}$  VS.  $I_C$ ,  $T_J = 100^\circ\text{C}$

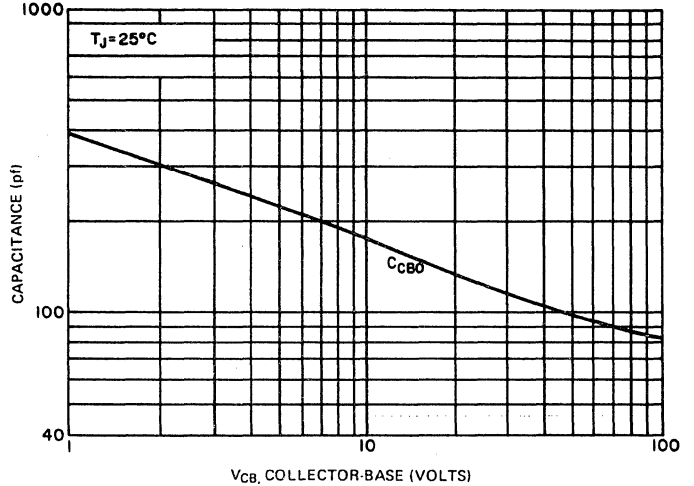

FIGURE 8. CAPACITANCE ( $C_{CB0}$ )

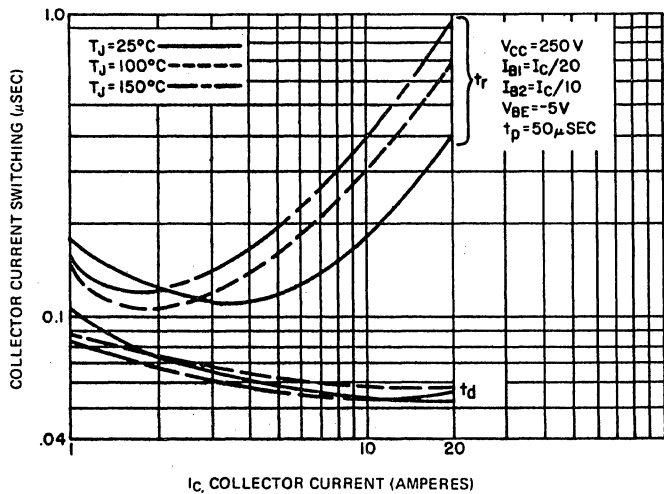

FIGURE 9. TURN-ON TIME (RESISTIVE LOAD)

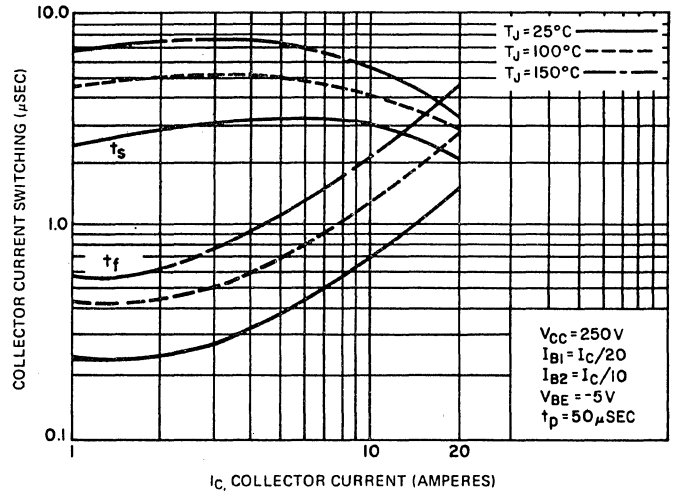

FIGURE 10. TURN-OFF TIME (RESISTIVE)

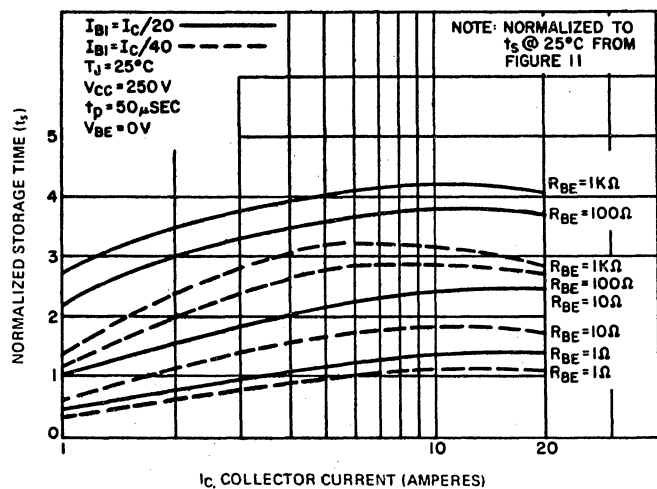

FIGURE 11. NORMALIZED RESISTIVE SWITCHING STORAGE TIME ( $R_{BE}$  VARIATIONS) VS. COLLECTOR CURRENT

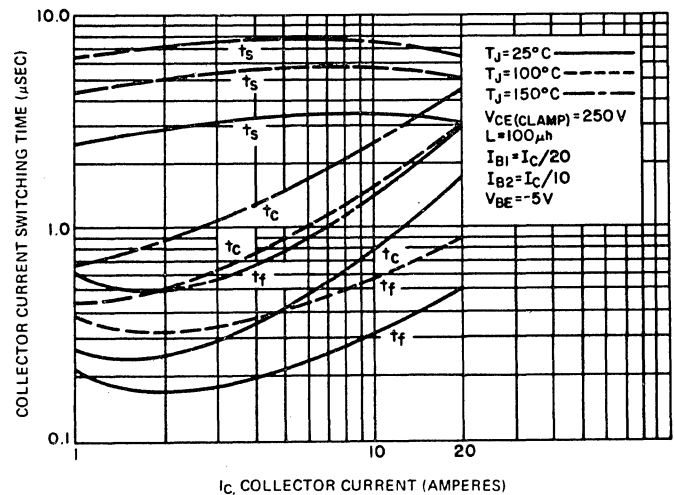
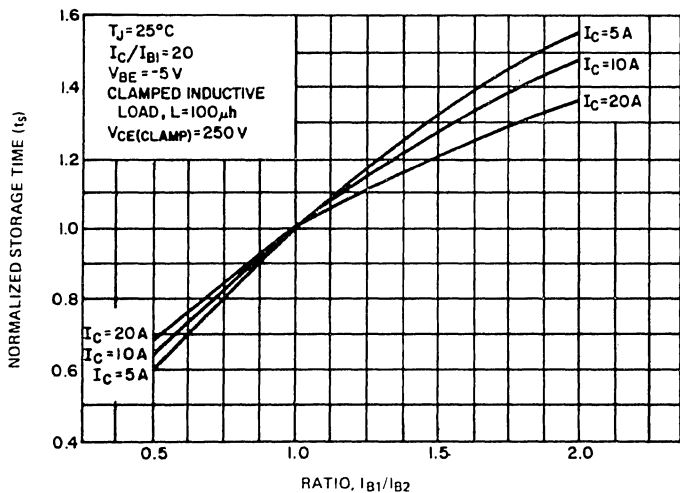
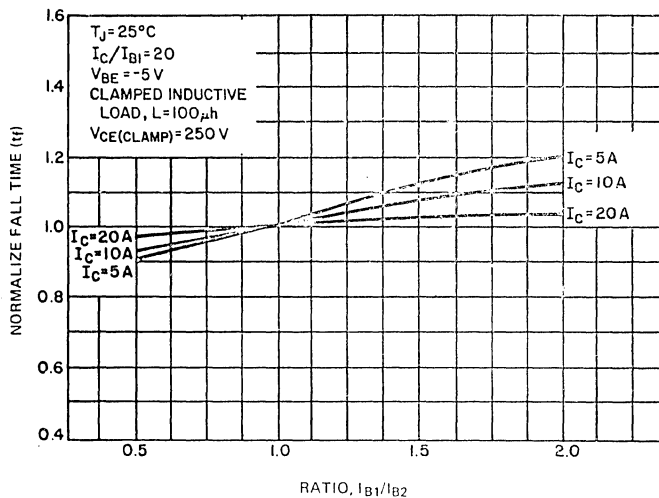

FIGURE 12. CLAMPED INDUCTIVE TURN-OFF TIME

## TYPICAL CHARACTERISTICS



**FIGURE 13. STORAGE TIME VARIATION WITH  $I_{B2}$**



**FIGURE 14. FALL TIME VARIATION WITH  $I_{B2}$**

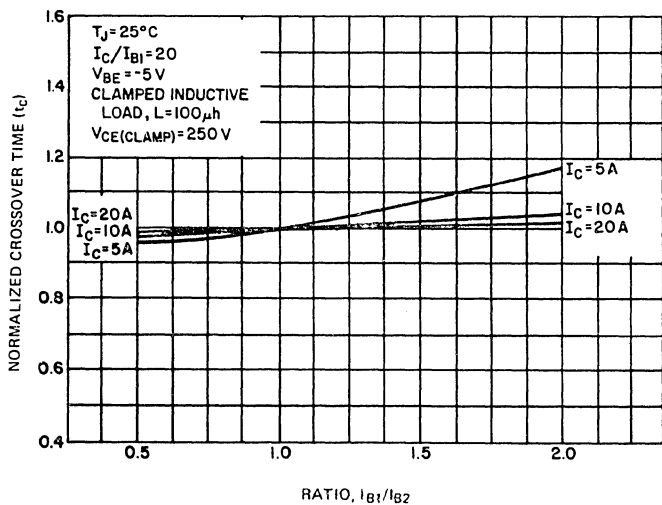

**FIGURE 15. CROSS-OVER TIME VARIATION WITH  $I_{B2}$**

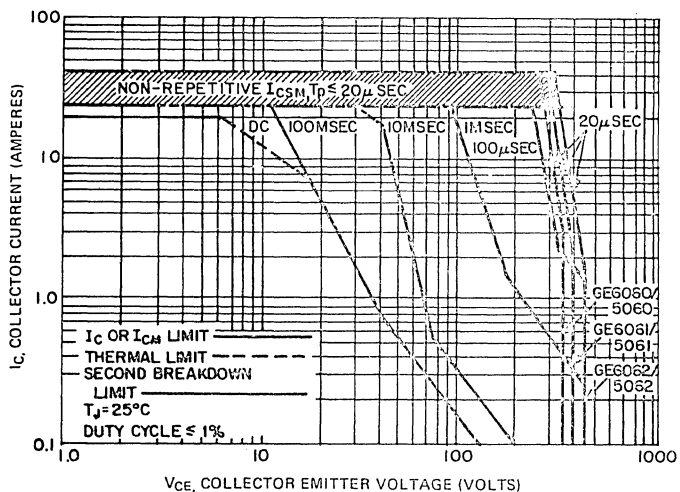

**FIGURE 16. FORWARD BIAS SAFE OPERATING AREA**

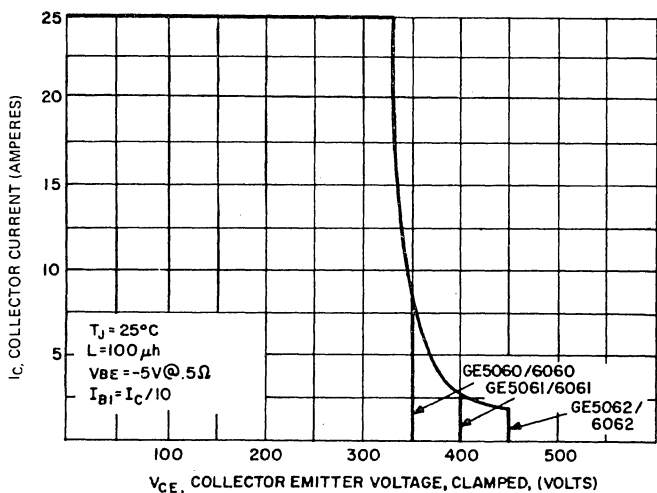

**FIGURE 17. REVERSE BIAS SAFE OPERATING AREA**

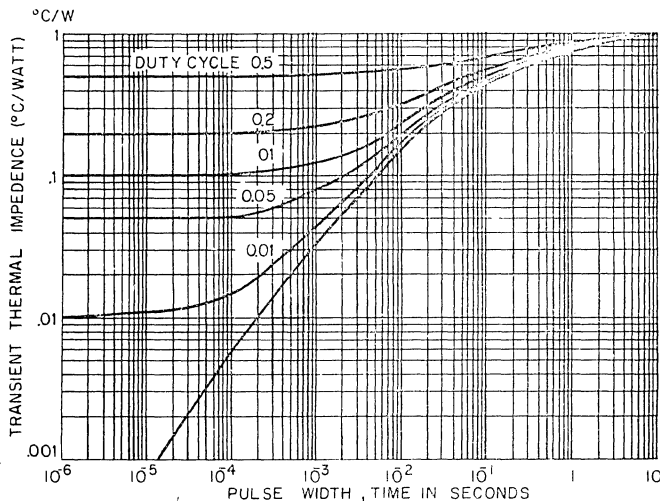

**FIGURE 18. TRANSIENT THERMAL RESPONSE**

## TYPICAL CHARACTERISTICS

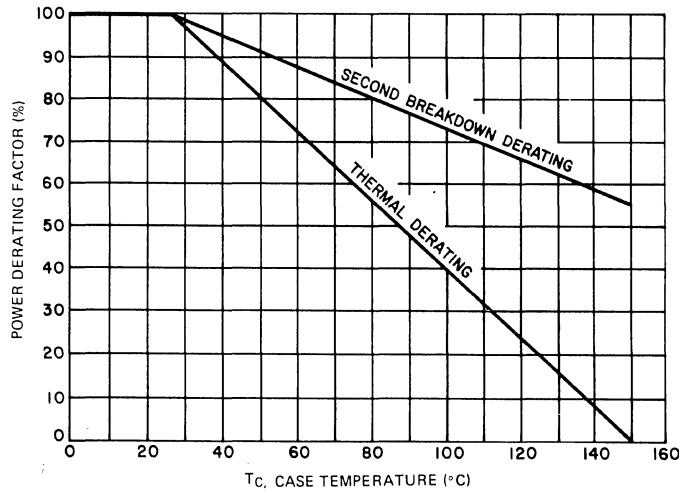

FIGURE 19. POWER DERATING

## DIODE CHARACTERISTICS

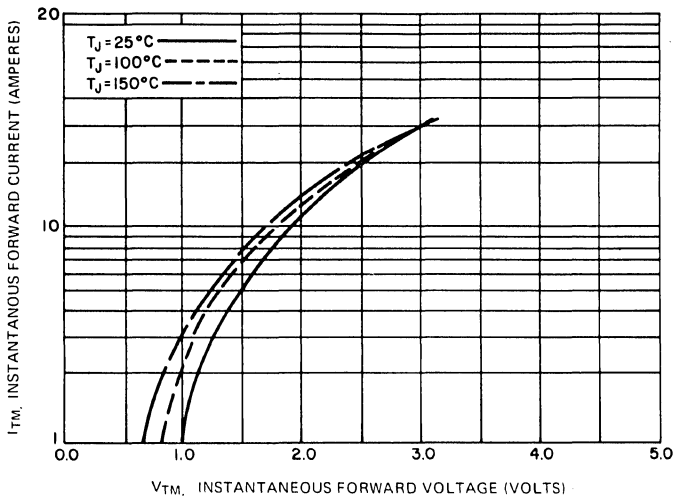

FIGURE 20. FORWARD CHARACTERISTICS

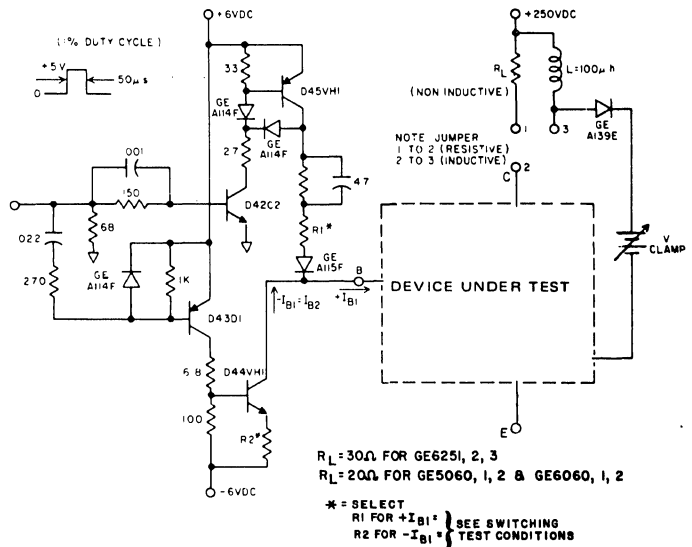

FIGURE 21. SWITCHING TIME TEST CIRCUIT