

TO : CUSTOMER

DATE : 2008.04.30

GREEN C&C TECH CO.,LTD

682-1 NEUNG-DONG HWASEONG CITY,KOREA

TEL : 82-31-233-3620,3621,3622

FAX : 82-31-233-3616

DOCUMENTATION FOR APPROVAL

PRODUCT : CCFL BACKLIGHT INVERTER(RoHS)

MODEL NAME : GH001HB

GCCT NAME : GCCT001AD

APPROVAL	CHECKED	WRITTEN

PLEASE RETURN ONE DOCUMENT AFTER APPROVED SIGN.

GREEN C&C TECH	INVERTER SPECIFICATION (GH001HB)	R&D DATE : 2008.04.30
----------------	-------------------------------------	--------------------------

NO	DATE	REVISION	PAGE
1	2005.09.22	FET Add The vendor F.C : FDS8958A APEC : AP4513	6
2	2006.12.28	Parts Vendor changed	6.7
3	2007.07.10	Open Voltage Specification changed (measure method is verified)	3
4	2007.11.26	Operating Temperature changed - -10~60 → -30~80	2
5	2008.04.30	PCB Vendor changed	7
REVISION HISTORY			

REV.											
Page											
REV.	0										
Page	12										
REV.	5	1	1	0	0	2	2	0	0	0	0
Page	1	2	3	4	5	6	7	8	9	10	11

GREEN C&C TECH	INVERTER SPECIFICATION (GH001HB)	R&D DATE : 2007.11.26
----------------	-------------------------------------	--------------------------

1. APPLICATION

This Document Specified The Detailed Product Requirements of Inverter
GH001HB

2. SUITABLE LOAD

LCD MODULE : 15" 2LAMP TFT LCD

3. ELECTRICAL CHARACTERISTICS

3-1. Absolute Maximum Ratings

ITEM	SYMBOL	SPEC	UNIT	REMARKS
INPUT VOLTAGE1	Vin1	10.8~13.2	V	
INPUT VOLTAGE2	Vin2	4.9~5.1	V	
OPERATING TEMPERATURE	Top	-30~80	°C	
STORAGE TEMPERATURE	Tstg	-30~80	°C	
RELATIVE HUMIDITY	RH	90	%	

3-2. Control Signal

PIN NO.	SYMBOL	STATUS	ACTION	REMARKS
CN1 #5	BKLT_ON	HIGH	LAMP(CCFL)-ON	2.4~5.25V
		LOW	LAMP(CCFL)-OFF	0.8V MAX

GREEN C&C TECH	INVERTER SPECIFICATION (GH001HB)	R&D DATE : 2007.07.10
----------------	--	--------------------------

3-3. Output Characteristics

ITEM	SYMBOL	CONDITION			SPECIFICATION			UNIT
		Vin1(V) (DC-IN)	BRT- ADJ	LAMP	MIN	TYP	MAX	
OUTPUT CURRENT	Io1(max)	12	0V	LAMP	7.0	7.5	8.0	mArms
	Io1(min)	12	5V	LAMP	2.5	3.0	3.5	
	Io2(max)	12	0V	LAMP	7.0	7.5	8.0	
	Io2(min)	12	5V	LAMP	2.5	3.0	3.5	
INPUT CURRENT	Iin(1)	12	0V	LAMP	0.6	0.9	1.2	ADC
FREQUENCY	F(1)	12	0V	LAMP	45	50	55	KHz
OPEN VOLTAGE ⁽¹⁾⁽²⁾	Vo1	12	0V	LAMP	1.45	-	-	KVrms
	Vo2	12	0V	LAMP	1.45	-	-	
	Vo	12	0V	LAMP	1.80	-	-	

- (1) Open Voltage Measurement : When measure Vo1, CN3(Vo2) is connected to lamp.
When measure Vo2, CN2(Vo1) is connected to lamp.
When measure Vo1,Vo2 simultaneously (Vo is sum of Vo1 and Vo2),
both CN2(Vo1) and CN3(Vo2) are not connected to lamp.

- (2) Ignition Sequence : When both Lamp1 and Lamp2 are in turn-off status, Vo1 is 1800Vrms and Lamp1 is ignited(turned on) first. And then Vo2 is 1500Vrms and Lamp2 is ignited later.
(Lamp1 is connected to CN2, Lamp2 is connected to CN3 respectively)

3.4 Test Circuit

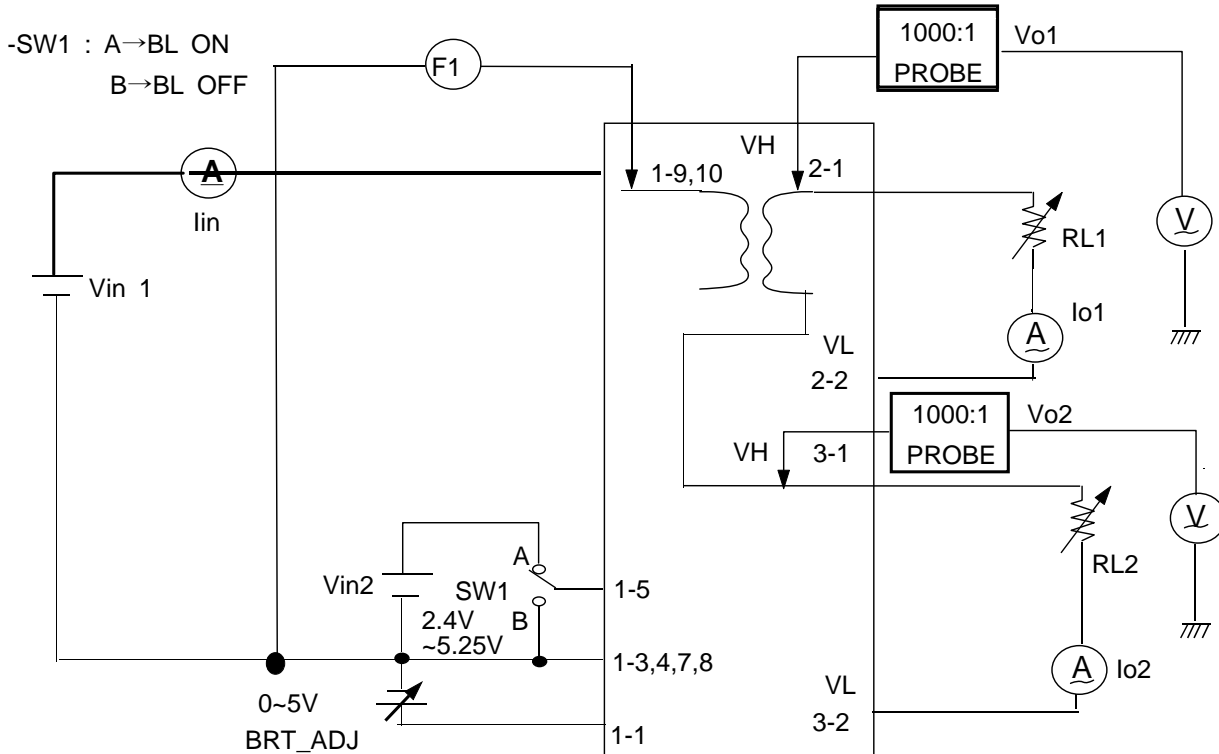

GREEN C&C TECH	INVERTER SPECIFICATION (GH001HB)	R&D DATE : 2005.09.22
----------------	-------------------------------------	--------------------------

4. INTERFACE

4.1 CN1 CONNECTOR :12505WR-10A00(P) (YEONHO) / EQUIVALENT

PIN NO	SYMBOL	REMARK
1	BRT_ADJ	0 ~ 5V
3,4,7,8	GND	GND
5	BL ON/OFF	CCFL Drive SIGNAL(Active HIGH)
2,6	N.C	
9,10	DC-IN(Vin)	DC INPUT Power (12V)

4.2 CN2 CONNECTOR : 20015WR-05A00(P) (YEONHO) / EQUIVALENT

PIN NO.	SYMBOL	REMARK
1	HOT	HIGH
2	COLD	LOW

4.3 CN3 CONNECTOR : 20015WR-05A00(P) (YEONHO) / EQUIVALENT

PIN NO.	SYMBOL	REMARK
1	HOT	HIGH
2	COLD	LOW

GREEN C&C TECH	INVERTER SPECIFICATION (GH001HB)	R&D DATE : 2005.09.22
----------------	-------------------------------------	--------------------------

5. APPEARANCE (UNIT : mm)

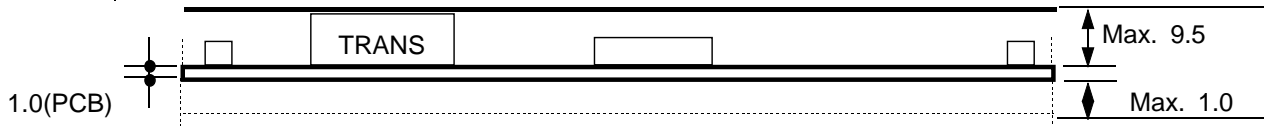
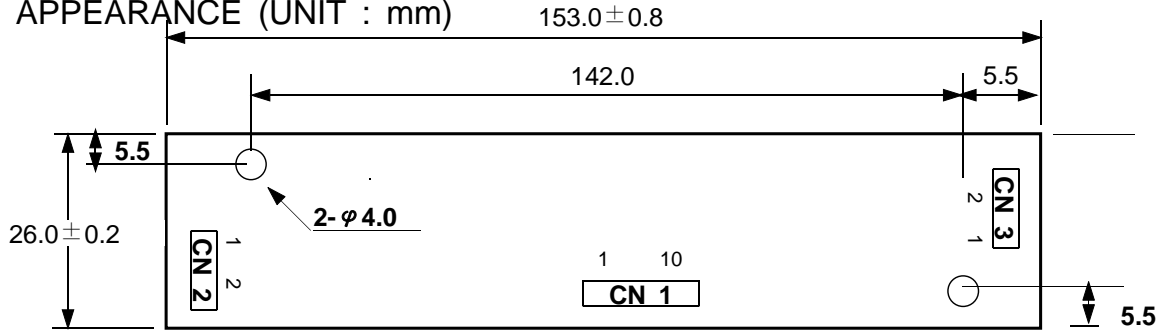

6. NOTATION OF LOT NUMBER

MARKING : BOTTOM OF PCB.

GH001HB
YYWWMMMM

GH001HB : MODEL NAME
 YY : YEAR OF PRODUCT 01,'02,'03,'04,...'10,'11,'12
 WW : WEEK OF PRODUCT 01,02,03,04,...52
 MMMM : SERIAL NUMBER 0001,0002.....9998,9999

GREEN C&C TECH	INVERTER SPECIFICATION (GH001HB)	R&D DATE : 2006.12.28
----------------	---	--------------------------

7.PART LIST

SYMBOL	NAME	1st		2nd	
		TYPE NO	MAKER	TYPE NO	MAKER
U1	IC	BD9883FV	ROHM		
U2,3	FET	AO4606	AOS	AP4503GM	APEC
		FDS8958A	F.C	SP8M3	ROHM
		P2803NVG	NIKO-SEMI	APM4548K	ANPEC
Q1	TR	SST2907A	ROHM	MMBT2907A	DIODES
		SBT2907A	AUK	KTN2907A	KEC
		MMBT2907A	PANJIT		
D2,3,4,5	DIODE	1SS355	ROHM	1N4148WS	DIODES
		SDS511	AUK	KDS160	KEC
		1N4148WS	PANJIT		
D6	DIODE	BAV99	DIODES	DAN217	ROHM
		SDS7000	AUK	KDS226	KEC
		BAV99	PANJIT		
D7	DIODE	DAN202K	ROHM	BAV70	DIODES
		SDS2838	AUK	KDS184	KEC
		BAV70	PANJIT		
ZD1,2	ZENER	UDZ5.6B	ROHM	UDZ5V6B	DIODES
		SDZ5V6	AUK	Z02W5.6V	KEC
		BZX84B5V6W	PANJIT		
C1	C-ELEC	220uF/25V NXB Series	SAMYOUNG	220uF/25V Series	SAMHWA
C13	MLCC	CL32F106Z	SEMCO	EQUIVALENT	
C2,18	"	CL21B103K	"	"	
C3	"	CL10C221J	"	"	
C5	"	CL10C561J	"	"	
C4,6,14	"	CL10B103K	"	"	
C7	"	CL10B224K	"	"	
C8	"	CL10B333K	"	"	
C9,12	"	CL10B473K	"	"	
C10,11	"	CL10F105Z	"	"	
C15	"	CL10C391J	"	"	
C16	"	CL10C122J	"	"	

GREEN C&C TECH	INVERTER SPECIFICATION (GH001HB)	R&D DATE : 2008.04.30
----------------	---	--------------------------

SYMBOL	NAME	1st		2nd	
		TYPE NO	MAKER	TYPE NO	MAKER
R1,R5	"	RC1608J303	"	"	
R3	"	RC1608J184	"	"	
R4	"	RC1608J393	"	"	
R6,R24	"	RC1608J683	"	"	
R7	"	RC1608J822	"	"	
R8,16,17	"	RC1608J102	"	"	
R9,13,18,25,26	"	RC1608J103	"	"	
R10,11,14,15	"	RC1608J470	"	"	
R23	"	RC1608J104	"	"	
R1,R5	"	RC1608J303	"	"	
R3	"	RC1608J184	"	"	
T1	TRANS	GT-209	NAMYANG	GT-209	SEJIN
		GT-209	DONGHEUNG	GT-209	GCCT
		GT-209	ANYON		
F1	FUSE	KE20	DAITO	KMS20	DAITO
CN1	CONNECTOR	12050WR-10A00(P)	YEONHO	EQUIVALENT	
CN2,3	"	20015WR_05A00(P)	YEONHO	EQUIVALENT	
PCB	PCB	GH001A REV4.0	WONKYENG	GH001A REV4.0	SOOJOO
		GH001A REV4.0	SEENDUCK	GH001A REV4.0	RAMI
		GH001A REV4.0	JOONGWON		

GREEN C&C TECH	INVERTER SPECIFICATION (GH001HB)	R&D DATE : 2005.09.22
----------------	-------------------------------------	--------------------------

8. PCB LAYOUT

GREEN C&C TECH	INVERTER SPECIFICATION (GH001HB)	R&D DATE : 2005.09.22
----------------	-------------------------------------	--------------------------

9. CIRCUIT

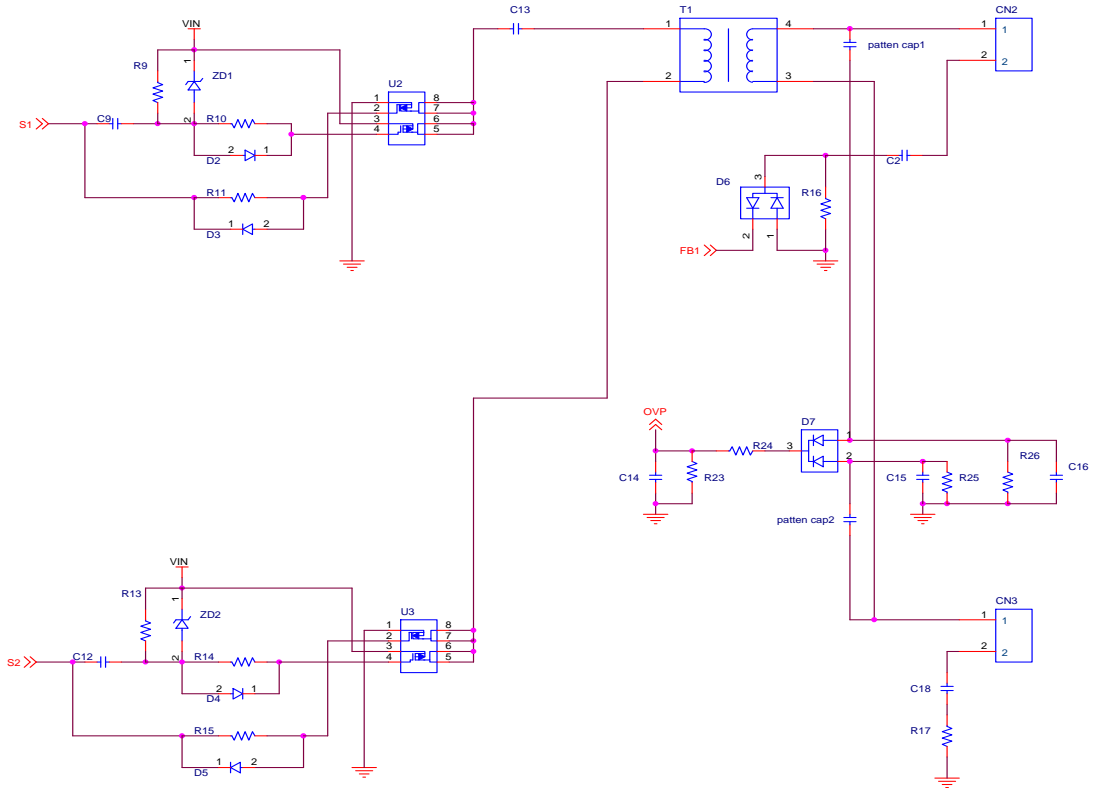
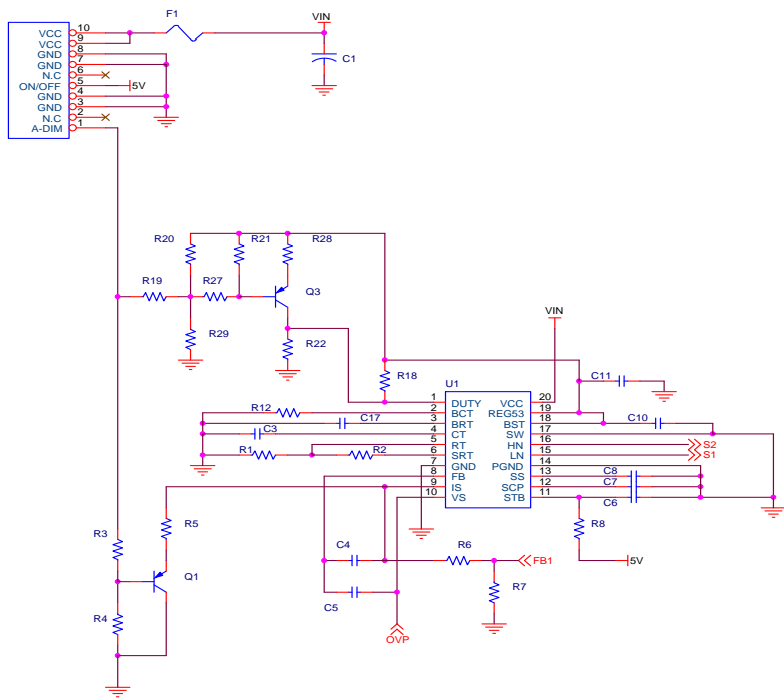

GREEN C&C TECH		
Title	GH001A	
Size	Document Number	Rev
A3	GCCT001A	4.0
Date:	Friday, June 17, 2005	Sheet 1 of 1

GREEN C&C TECH	INVERTER SPECIFICATION (GH001HB)	R&D DATE : 2005.09.22
----------------	-------------------------------------	--------------------------

10. RELIABILITY TEST SPEC

NO.	ITEM	CONDITIONS AND METHOD
1	High Temperature Storage Test	Temp : 80℃ Duration 500hrs
2	Low Temperature Storage Test	Temp : -30℃ Duration 500hrs
3	High Temperature High Humidity Storage	Temp : 40℃ Humid 95%RH Duration 500hrs
4	High Temperature High Humidity Operation test	Temp : 40℃ Humid 95%RH Duration 1000hrs
5	Thermal Shock Test	Temp -30℃ ↔ 70℃,250cycle (30min) (30min)
6	Vibration test	Amplitude :1.5mm Frequency :10~55Hz Position : three perpendicular planes Duration 1000hrs
7	High Temperature Operation test	Temp : 80℃ Duration 72hrs
8	Low Temperature Operation test	Temp : -30℃ Duration 72hrs

GREEN C&C TECH	INVERTER SPECIFICATION (GH001HB)	R&D DATE : 2005.09.22
----------------	-------------------------------------	--------------------------

11.FLOW CHART

MODEL (TYPE)	(GH001HB)	REVISION	4
WRITER	J.M.YOON	(FLOW CHART)	
FLOW CHART	PROCESS	EQUIPMENTS	REFERENCES
	Raw Material		PART LIST
	Cream-solder Printing of F-side	Cream-solder Printer	
	Discrete Device Assembly	Low · High Mounter	
	Reflow Soldering	Reflower	
	Visual Inspection	Microscope	
	PCB Marking	MARKING	
	Preparing Process		
	Soldering By Hand for Discrete Components		
	Visual Inspection		
		Silicon Dispenser	
	PCB Division		
	Aging	Power Supply, Aging Box	2h
	Electrical Characteristic Inspection	Testing SYSTEM, Testing JIG	
	Insulator Attachment		
	Package		
Outgoing Inspection	Testing SYSTEM, Testing JIG	List of Inspection	
Shipping			
Based on standard rule	GCCT001AD		

GREEN C&C TECH	INVERTER SPECIFICATION (GH001HB)	R&D DATE : 2005.09.22
----------------	-------------------------------------	--------------------------

12. PACKING
12.1 BOX

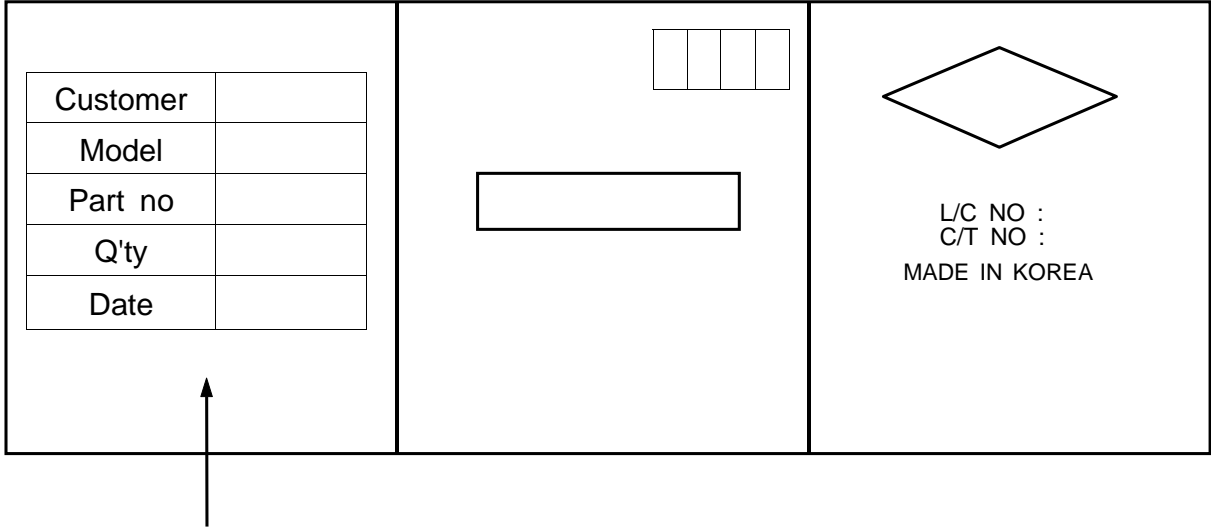

Customer	
Model	GH001HB
Part no	
Q'ty	000 EA
Date	00.00.00

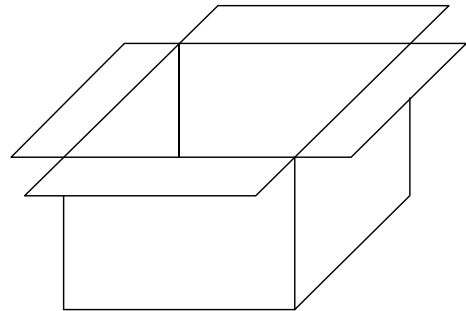

12.2 TRAY

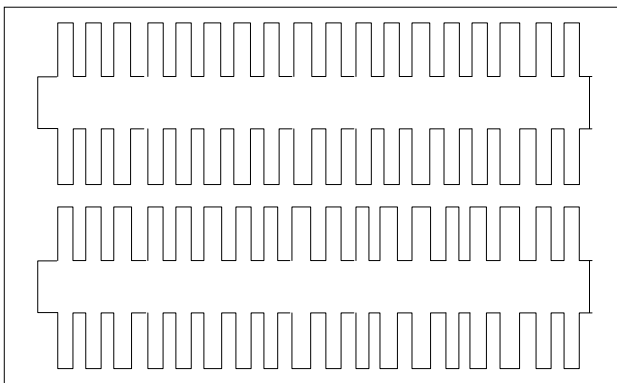

1 TRAY : 36EA
1 BOX : 9TRAY (324EA)

SYMBOL	TYPE NO
PACKING-TRAY	383*319*36
PACKING-BOX	393*324*358
PACKING-PAD	393*324*3

1. MATERIAL LIST FOR SAFETY GH001HB

1.1 LIST

SYMBOL	NAME	TYPE NO.	MANUFACTURER	DESCRIPTION
F1	FUSE	KE20	DAITO COMMUNICATION APPARATUS CO LTD	UL FILE NO. E59783
		KMS20	DAITO COMMUNICATION APPARATUS CO LTD	UL FILE NO. E59783
PCB	PRINTED WIRING BOARD	FR-4	SOOJOO	UL FILE NO : E173459
			WONKYENG	UL FILE NO : E202541
			SEENDUCK	UL FILE NO : E108545
			JOONGWON	UL FILE NO : E111948
			RAMI	UL FILE NO : E162926
CN1	CONNECTOR	12505WR-10A00	YEONHO	UL:E108706
		53261-1071	MOLEX	UL FILE NO:E29179 NYLON 66 UL94V-0
CN2,3	CONNECTOR	20015WR-05A00	YEONHO	UL:E108706
		SM02(8.0)-BHS	JST	UL FILE NO : E60389 POLYAMIDE RESIN UL94V-0
T1	TRANSFORMER	GT-209	NAMYANG ELECTRONICS	CLASS A (105 de.C) SEE TRANS SPEC
			GCCT	CLASS A (105 de.C) SEE TRANS SPEC
			SEJIN	CLASS A (105 de.C) SEE TRANS SPEC
			ANYON	CLASS A (105 de.C) SEE TRANS SPEC
			DONG HEUNG	CLASS A (105 de.C) SEE TRANS SPEC

CUSTOMER : GREEN C&C CO., LTD.

<h1>SPECIFICATION</h1>		SHEET NO.	
		D A T E	2005. 04. 21.
PART NAME	INVERTER TRANS	MODEL NAME	
PART NO.	GT-209	DESCRIPTION	EFD18x20 (EEA17.7mm)

1. GENERAL SPECIFICATION

1) SCOPE

This specification applies to part number GT-209 INVERTER TRANS for use in color TV and Monitor with is supplied for GREEN C&C CO., LTD.

2. GENERAL PREFERENCE

The reinspection & reapproval is required to change the structure, quality, progress of this Specification.

3. ABSOLUTE REGULARITY

- 1) Keep Temperature : -25℃ ~ 85℃
- 2) Keep Humidity : 20% ~ 95%
- 3) Use Temperature : -10℃ ~ 70℃
- 4) Use Humidity : 20% ~ 85%

4. MECHANICAL CHARACTERISTIC

1) TERMINAL TENSION INTENSITY

After fix the body, The Terminal Shall withstand for 30 seconds without losing when a static load of 1.0Kg is applied to drawing direction of the Terminal.

2) TERMINAL BEND INTENSITY

The Terminal shall withstand without breakage and bend when it returns after bend 1 time to the left side and 1 time right side with a static load.

3) VIBRATION TEST

After fix a body of the vibration board, The terminal shall withstand without losing and bend when it operates vibration test of 3 directions(X,Y,Z) for 2hours.

5. ELECTRICAL CHARACTERISTIC

1) INSULATION RESISTANCE

- ① Primary COIL TO CORE : Shall be more than
- ② Primary COIL to Secondary COIL : Shall be more than
- ③ Secondary COIL TO CORE : SHALL be more than 100MΩ when measured with DC 500V

2) WITHSTAND VOLTAGE

- ① Primary COIL to Secondary COIL : Shall be no damage when measured AC2.5KV, 5mA for 1 Min.
- ② P COIL TO CORE : SHALL be no damage when measured AC1.5KV, 5mA for 1 Min.
- ③ S COIL TO CORE : SHALL be no damage when measured AC1.5KV, 5mA for 1 Min.

NO	REVISION	DATE	CHECK	DRAWN	CHECKED	APPROVED
1						
2						
3						
4						

<h1>SPECIFICATION</h1>		SHEET NO.	
		D A T E	2005. 04. 21.
PART NAME	INVERTER TRANS	MODEL NAME	
PART NO.	GT-209	DESCRIPTION	EFD18x20 (EEA17.7mm)

6. APPEARANCE & DIMENSION (UNIT:mm)

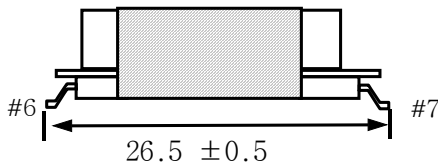
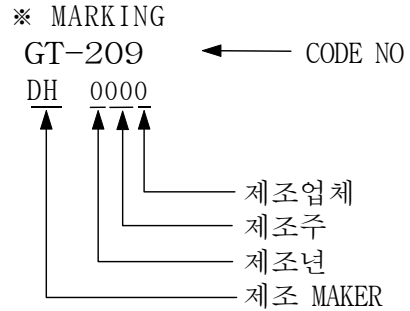
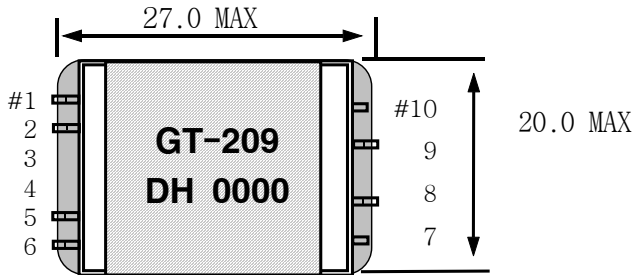

- ※ PRODUCTION LINE
- 1. A : CHUN AN
 - 3. K : TIANJIN
 - 4. B : BAZHOU
 - 5. D : DONGGUAN
 - 6. Y : YANTAI

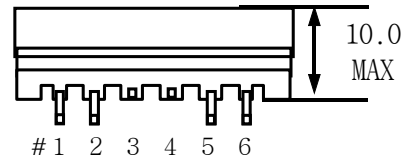
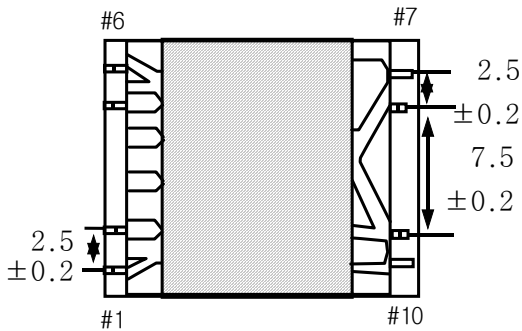

* PIN REMOVE: #3, 4

* PIN LENGTH : BEFORE SOLDERING

NO	REVISION	DATE	CHECK	DRAWN	CHECKED	APPROVED
1						
2						
3						
4						

CUSTOMER : GREEN C&C CO., LTD.

<h1>SPECIFICATION</h1>		SHEET NO.	
		D A T E	2005. 04. 21.
PART NAME	INVERTER TRANS	MODEL NAME	
PART NO.	GT-209	DESCRIPTION	EFD18x20 (EEA17.7mm)

7. SCHEMATIC DIAGRAM

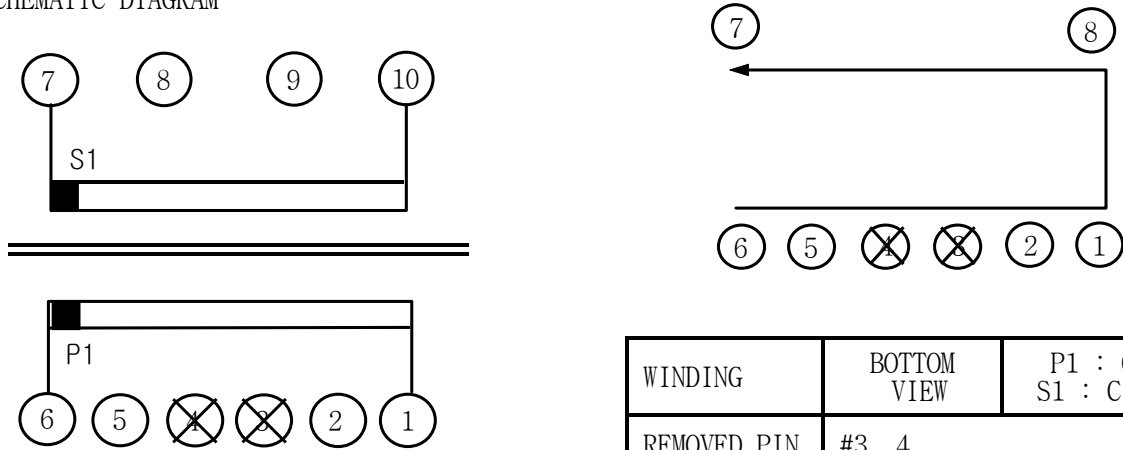

8. WINDING SPECIFICATION

NO	TERMINAL		WIRE	TURNS	WINDING METHOD	INSULATION			
	S	F				MATERIAL	T/W	TS	
S1	6	1	1UEW 0.35Ø	TOTAL 2800t	466.0	RANDOM	-	-	-
					467.0	RANDOM	-	-	-
					467.0	RANDOM	-	-	-
					467.0	RANDOM	-	-	-
					467.0	RANDOM	-	-	-
					466.0	RANDOM	-	-	-
					BLANK	-	-	-	-
P1	7	10	Grd2 0.03Ø	18t	SOLENOID	-	-		
CORE FIXING TAPE						POLYESTER TAPE	0.025t, W=5.0mm	3	
OUTER WRAP TAPE						POLYESTER TAPE	0.025t, W=13.5	1.5MIN	

NO	REVISION	DATE	CHECK	DRAWN	CHECKED	APPROVED
1						
2						
3						
4						

CUSTOMER : GREEN C&C CO., LTD.

<h1>SPECIFICATION</h1>		SHEET NO.	
		D A T E	2005. 04. 21.
PART NAME	INVERTER TRANS	MODEL NAME	
PART NO.	GT-209	DESCRIPTION	EFD18x20 (EEA17.7mm)

9. ELECTRICAL CHARACTERISTIC

NO.	ITEM	TERMINAL	SPECIFICATION	REMARKS
1	INDUCTANCE (Ls MODE)	4 - 2 6 - 7	91.0 uH ±10% 1.93 H ±12%	HP-4284A at 1.0KHz, 1Vrms
2	LEAKAGE (Ls MODE)	4 - 2 6 - 7	25 uH MAX 385 mH MIN	at 1.0KHz, 1Vrms
3	DC RESISTANCE	6 - 7	1.92 KΩ ±12%	WHEATSTONE BRIDGE YEW TYPE 2755 HIOKI TYPE 3220
4	WITHSTANDING VOLTAGE	PRIMARY TO SECONDARY	AC 2.5KV 1MINUTE CURRENT 5mA	KIKUSUI TOS-9200
		P COIL TO CORE	AC 1.5KV 1MINUTE CURRENT 5mA	
		S COIL TO CORE	AC 1.5KV 1MINUTE CURRENT 5mA	
5	INSULATION RESISTANCE	PRIMARY TO SECONDARY	100Mohm MINIMUM at DC 500V	KIKUSUI TOS-9200
6	LAYER SHORT	START & FINISH	AC <u>1.4</u> [KV] , FREQUENCY <u>60</u> [Hz]	

NO	REVISION	DATE	CHECK	DRAWN	CHECKED	APPROVED
1						
2						
3						
4						

CUSTOMER : GREEN C&C CO., LTD.

<h1>SPECIFICATION</h1>		SHEET NO.	
		D A T E	2005. 04. 21.
PART NAME	INVERTER TRANS	MODEL NAME	
PART NO.	GT-209	DESCRIPTION	EFD18x20 (EEA17.7mm)

13. INTERNAL CONSTRUCTION

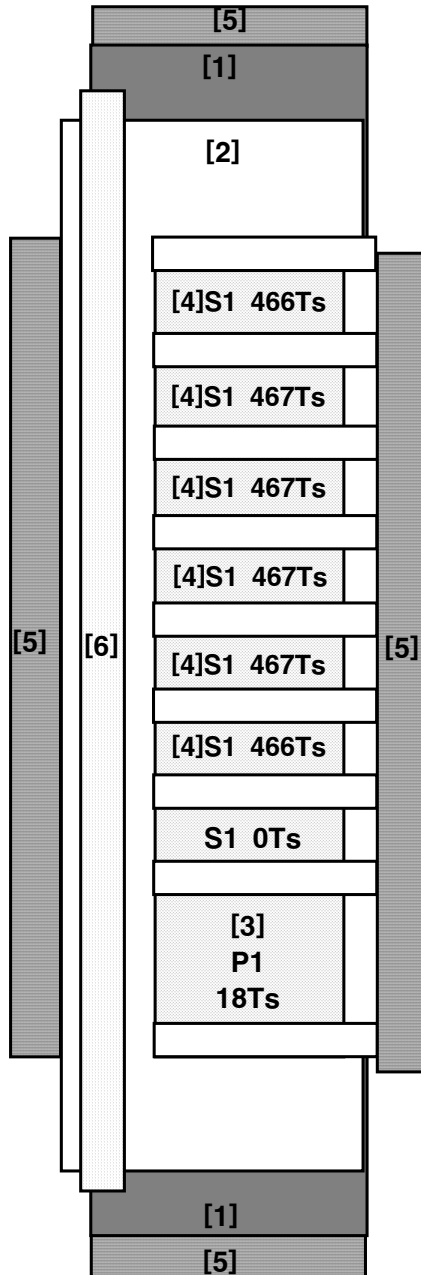

PIN #7 ~ #10

* WINDING 
 * INSUATION TAPE 

PIN #1 ~ #6

NO	REVISION	DATE	CHECK	DRAWN	CHECKED	APPROVED
1						
2						
3						
4						

CUSTOMER : GREEN C&C CO., LTD.

SPECIFICATION		SHEET NO.	
		D A T E	2005. 04. 21.
PART NAME	INVERTER TRANS	MODEL NAME	
PART NO.	GT-209	DESCRIPTION	EFD18x20 (EEA17.7mm)

6. MATERIAL LIST

NO	MATERIAL	ITEM	MANUFACTURER	UL FILE NO
1	CORE	EFD 18 x 20 (GAP : B GAP) PL-7,PM-7,YP-2	SAM HWA ELECTRONICS CO., LTD. ISU CERAMICS CO.,LTD. YOUNG HWA FERRITE CO., LTD.	
2	BOBBIN	EFD 18 x 20(EEA17.7) L.C.P(E4008K) (94V-0)	SUMITOMO CHEMICAL CO., LTD.	E54705M
3	PRI WIRE	1UEW 0.35	DONGYANG ELECTRONICS CO., LTD. YOUNG WHA SA CO.,LTD.	E102761S E141925S
4	SEC WIRE	GRD2 0.03Ø	ELEKTRISOLA SDN BHD.	E143312M
5	INSULATION TAPE	POLYESTER TAPE 0.025t x 13.5mm	DUCK SUNG HITECH CO., LTD. (CAT No:DTS-204A) HYUN DAI CHEMICAL CO., LTD. (CAT No:800(a))	E105147
		POLYESTER TAPE 0.025t x 4.0mm		E162848S
6	INSULATOR	PETP FILM	SKC LTD	E74359S
7	IMPREGNATION	EPOXY SR-337, KH-337	SE GYE CHEMICAL CO., LTD.	
8	SOLDER BAR	SN98CU2-B20	SAMWOO ALLOYMETAL CO., LTD.	

NO	REVISION	DATE	CHECK	DRAWN	CHECKED	APPROVED
1						
2						
3						
4						

CUSTOMER : GREEN C&C CO., LTD.

<h1>SPECIFICATION</h1>		SHEET NO.	
		D A T E	2005. 04. 21.
PART NAME	INVERTER TRANS	MODEL NAME	
PART NO.	GT-209	DESCRIPTION	EFD18x20 (EEA17.7mm)

* BOBBIN

SUMITOMO CHEMICAL CO.,LTD. E54705 (M)
5-33 KITAHAMA 4-CHOMA CHUO-KU, OSAKA JAPAN
WILMINGTON DE 19898

Mtl Dsg	Col	Min Thk mm	UL94 Flame Class	Elec with Imp	Mech w/o Imp	H W	H A	V T	4 9	C T
Liquid Crystal Polyester (LCP), designated "EKONOL" or "SUMIKASUPER", furnished in the form of pellets.										

E-4008(k)	NC,WT,BK	0.30	94V-0	130	130	130	-	-	-	-
		0.75	94V-0	220	180	220	3	4	-	-
		1.5	94V-0	220	200	240	2	4	-	-
		3.0	94V-1	220	200	240	1	4	0	5 4

Reports : November 10, 1994 August 17, 1992 August 17, 1992

Replaces E547050010 dated August 16, 1994. (Cont. or CO11 card)
 683604011 n7047 Underwriters Laboratories Inc. Dh/0246672

* WIRE (PRI)

DONG YANG ELECTRONICS IND CO LTD E102761 (S)
660-1 BANWOL-RI TAIAN-EWB HWASUNG-GUN,
KYUNGGI-DO KOREA

Mtl Dsg	BC	Cost typ	OC	ANSI Type	TI
AI-EIW	Polyesterimide		Polyamideimide	MW35	200
EIW	Polyesterimide			MW30	180
NY-EIW	Polyester- amide-imide		Polyamide	MW96	180
NY-PEW	Polyester		Polyamide	MW24	155
NY-PEW(F)	Polyester		Polyamide	MW24	155
NY-UEW	Polyurethane		Polyamide	MW23	130
UEW	Polyurethane		-	MW75	130

Marking: Company name or "E102761" and material designation or marked designation on package or reel, and recognized Component Mark.

NO	REVISION	DATE	CHECK	DRAWN	CHECKED	APPROVED
1						
2						
3						
4						

CUSTOMER : GREEN C&C CO., LTD.

<h1>SPECIFICATION</h1>		SHEET NO.	
		D A T E	2005. 04. 21.
PART NAME	INVERTER TRANS	MODEL NAME	
PART NO.	GT-209	DESCRIPTION	EFD18x20 (EEA17.7mm)

* WIRE (PRI)

OBMW2 May 2, 1997
Component -Magnet Wire

YOUNG WHA SA CO LTD E141925 (S)
256-1 DODANG-DONG WONMI-KU BUCHON, KYONGGI-DO
421-130 KOREA

Mtl	Cost typ	Overcoat	ANSI Typ (+)	TI
Dsg	BC			
AEW-R	Modified Polyester	Polyamideimide	MW73-C	200
AI-EIW	Modified Polyester	Polyamideimide	MW35-C	200
UEW-F	Polyurethane	-	MW79-C	155
NPW	Polyester-nylon	Nylon	MW24-C	155
NUW	Polyurethane-nylon	Nylon	MW28-C	130
YHW-B	Polyurethane	-	MW75-C	130
UEW-B	Polyurethane	-	MW75-C	130

Reports: June 19, 1992; June 19, 1992; June 19, 1992, January 4, 1994; November 7, 1995; June 24, 1996; January 30, 1997.

Replaces E141925A dated March 4, 1997. (Cont. on B card)
746041001 H0110 Underwriters Laboratories Inc. D11/0213429 24

* WIRE (SEC)

OBMW2 January 15, 1997
Component -Magnet Wire

ELEKTRISOLA (MALAYSIA) SDN BHD E143312 (M)
(B-cont.from A card)

Polysol 155	P155	Polyurethane	-	MW-79	155
				MW-75	130
Polysol 155g	Pg155	Polyurethane	-	MW75	130
Polysol 155p	Pp155,Gp155	Polyurethane	-	MW79	155
Polysol 160	p160	Polyurethane	-	MW-79	155
Polysol 160	P180,G180	Polyurethane	-	MW79	155

Marking: Company name, material designation or marked designation on package or reel and Recognized Component Mark.

See General Information Preceding These Recognitions.

For use only in equipment where the acceptability of the combination is determined by Underwriters Laboratories Inc.

Reports: March 13, 1992; March 13, 1992; March 13; 1992, March 13, 1992; March 13, 1992.

Replaces E143312 E143312B dated April 20, 1992.
768673002 N3347 Underwriters Laboratories Inc. D11/0210461

NO	REVISION	DATE	CHECK	DRAWN	CHECKED	APPROVED
1						
2						
3						
4						

0705-00양식04

DONG HEUNG ELECTRONICS CO., LTD.

CUSTOMER : GREEN C&C CO., LTD.

<h1>SPECIFICATION</h1>		SHEET NO.	
		D A T E	2005. 04. 21.
PART NAME	INVERTER TRANS	MODEL NAME	
PART NO.	GT-209	DESCRIPTION	EFD18x20 (EEA17.7mm)

* INSULATION TAPE

<p>QANZ2 Insulating Tape-Component DUCK SUNG HITECH CO LTD DAESUNG BLDG 677 JAYANG-DONG KWANG JIN-KU SEOUL 133-190, KOREA</p>	E105147
<p><u>Polyester film insulating tape, acrylic adhesive, Cat. No. DTS-204, rated 130 C.</u> Acetate cloth insulating tape, acrylic adhesive, Cat. No. 231*, rated 105 C. Glass cloth insulating tape, rubber adhesive, Cat. No. 220-B, rated 130 C. Glass cloth insulating tape, silicone adhesive, Cat. No. 221H*, rated 180 C. Acetate cloth insulating tape, rubber adhesive, Cat. No. DTS-230, rated 105 C. Nomex (Aramid fiber) film insulating tape with non-woven polyester fiber reinforcement, acrylic adhesive, Cat. No. DTS-241*, rated 130 C. Polyester film insulating tape, acrylic adhesive, Cat. No. DTS-280*, rated 130 C. PET (polyester) film insulating tape, synthetic rubber adhesive, Cat. No. DTS -204R %, rated 130 C. PET(polyester) film insulated tape, acrylic adhesive, Cat. No. DTS-204F*#, rated 130C. Flame retardant cotton cloth tape, rubber adhesive, Cat. No. DTS-250F**. Flame retardant acetate cloth tape, rubber adhesive, Cat. No. DTS-232F+. Flame retardant Aluminum foil tape, acrylic adhesive, Cat. No. DTS-800A+. Flame retardant Aluminum foil with PET film tape, acrylic adhesive, Cat. No. DTS-810+. Flame retardant Copper foil tape, acrylic adhesive, Cat. No. DTS-820+. Flame retardant Nickel coated Polyester Fiber tape, acrylic adhesive, Cat. No. DTS-830+. Glass cloth insulating tape, acrylic adhesive, Cat. No. DTS-221F*, rated 155 C. PET (polyester) film insulating tape with non-woven polyester fiber reinforcement, rubber adhesive, Cat. No. DTS-280R@, rated 130C. PET (Polyester) film insulating tape, acrylic adhesive , Cat. No. DTS-204B&, rated 130 C. PET (Polyester) film insulating tape, acrylic adhesive , Cat. No. DTS-204K^, rated 130 C. * - Complies with flame retardant requirements when so marked. + - Must be marked "Flame Retardant". # - May be marked: "Film side CTI Performance Level Category PLC=3 Voltage 235, per UL 746A/ASTM D 3638", and/or "Adhesive side CTI Performance Level Category PLC=0 Voltage 600, per UL 746A/ASTM D 3638" or equivalent. % - May be marked: "Film side CTI Performance Level Category PLC=2 Voltage 325, per UL 746A/ASTM D 3638", and/or "Adhesive side CTI Performance Level Category PLC=1 Voltage 575, per UL 746A/ASTM D 3638" or equivalent. @ - May be marked: "Film side CTI Performance Level Category PLC=0 Voltage 600+, per UL 746A/ASTM D 3638," and/or "Adhesive side CTI Performance Level Category PLC=0 Voltage 600+, per UL 746A/ASTM D 3638" or equivalent. & - May be marked: "Film side CTI Performance Level Category PLC=2 Voltage 260, per UL 746A/ASTM D 3638," and/or "Adhesive side CTI Performance Level Category PLC=0 Voltage 600, per UL 746A/ASTM D 3638" or equivalent. ^ - May be marked: "Film side CTI Performance Level Category PLC=2 Voltage 250, per UL 746A/ASTM D 3638," and/or "Adhesive side CTI Performance Level Category PLC=0 Voltage 600, per UL 746A/ASTM D 3638" or equivalent.</p> <p>Marking: Company name or trademark or file number "E105147" and catalog designation printed on carton, wrapper or core.</p>	

NO	REVISION	DATE	CHECK	DRAWN	CHECKED	APPROVED
1						
2						
3						
4						

CUSTOMER : GREEN C&C CO., LTD.

<h1>SPECIFICATION</h1>		SHEET NO.	
		DATE	2005. 04. 21.
PART NAME	INVERTER TRANS	MODEL NAME	
PART NO.	GT-209	DESCRIPTION	EFD18x20 (EEA17.7mm)

* INSULATION TAPE

OANZ2 April 7, 1997
 Component - Insulating Tape E162848 (S)

HYUN DAI CHEMICAL CO LTD
 258 YEULMI-RI SILCHON-MYON KWANGJU, KYONGGI-DO
 464-870 KOREA

~~Polyester tape with acrylic adhesive, Cat. No. 800(a) for use at temperatures not exceeding 130°C
 (a) Comparative Tracking Index (CTI) assigned PLC = 0, voltage = 600V or greater, CTI600.
 Marking: Company name, catalog designation and temperature rating printed on carton, wrapper or core.~~

See General Information Preceding These Recognitions.
 For use only in equipment where the acceptability of the combination is determined by Underwriters Laboratories Inc

Reports: October 20, 1994.

Replaces E162848 dated October 21, 1994.
 105798001 Underwriters Laboratories Inc. D11/0264017
 22

NO	REVISION	DATE	CHECK	DRAWN	CHECKED	APPROVED
1						
2						
3						
4						

CUSTOMER : GREEN C&C CO., LTD.

<h1>SPECIFICATION</h1>		SHEET NO.	
		D A T E	2005. 04. 21.
PART NAME	INVERTER TRANS	MODEL NAME	
PART NO.	GT-209	DESCRIPTION	EFD18x20 (EEA17.7mm)

* INSULATOR

MFZ2 August 3, 1987
 Component - PLastics
 SKC LTD. E74359 (S)
 633 SUWON CHNGJA-DONG, KYONGKI-DO 170
 KOREA.

	Min	UL94	Elec	RTI						
	Thk	Flame		Moch	w/o	H	H	V	D	C
Mti Dag	Coi	mm	Class	with	Imp	I	I	R	T	I
Polyethylene terephthalate [PETP] film, furnished in the form of sheetS.										
Skyrol	NC	0.002	--	105	105	105	-	-	-	-

Marking: Company name or trademark "SKC" and grade designation on conlainer or wrapper.

See General information Preceding These Recognitions.

UL94 small scale test data dons not pertain to building materials furoishings and related contents.
 UL94 small scale test data is intended solaiy for deterrmming the flammability ot plastic matorials
 used in the components and parts of and product doives and appliances. where the acceptability of
 the combination is determined by ULL

Raport Nayember 3, 1980

Replaces E74359 dated February 26, 1987, filed Sunkyong Chemical Ltd.
 295388002 H7042 Underwritars Laboratories Inc. D11/0079552

NO	REVISION	DATE	CHECK	DRAWN	CHECKED	APPROVED
1						
2						
3						
4						

CUSTOMER : GREEN C&C CO., LTD.

<h1>SPECIFICATION</h1>		SHEET NO.	
		D A T E	2005. 04. 21.
PART NAME	INVERTER TRANS	MODEL NAME	
PART NO.	GT-209	DESCRIPTION	EFD18x20 (EEA17.7mm)

* CORE SIZE (Unit:mm)

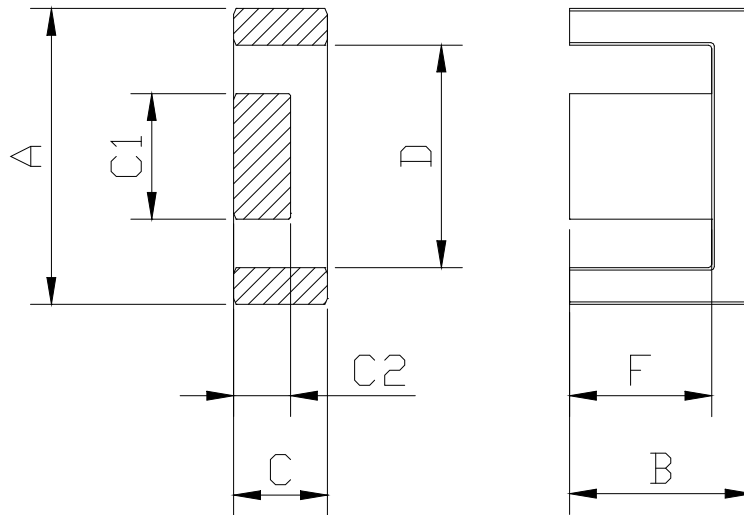

A	B	C	C1	C2	D	F
17.7±0.30	10.2±0.10	5.6±0.15	7.5±0.15	3.4±0.15	13.1 _{min}	7.8±0.20

*. NO GAP → AL-value (nH/N2) : 1280

*. B GAP → AL-value (nH/N2) : 283.55

NO	REVISION	DATE	CHECK	DRAWN	CHECKED	APPROVED
1						
2						
3						
4						

CUSTOMER : GREEN C&C CO., LTD.

<h1>SPECIFICATION</h1>		SHEET NO.	
		D A T E	2005. 04. 21.
PART NAME	INVERTER TRANS	MODEL NAME	
PART NO.	GT-209	DESCRIPTION	EFD18x20 (EEA17.7mm)

* CORE

Symbol	Unit	Temp	PL-7
$\mu i a c$		-	2400 ± 25%
P _{cv} 100KHz, 200mT	KW/m ³	23℃	650
		80℃	450
		100℃	410
B _{ms} H=1200A/m	mT	23℃	490
		100℃	380
H _{cms}	A/m	23℃	12
Br	mT	23℃	150
T _c	℃	-	>220
p	Ω . m	23℃	5
d	kg/m ³		4.85x10 ³

SYMBOL	UNIT	CONDITION	PM-7
$\mu i a c$		25℃	2400 ± 25%
B at H	mT	H=1200(A/m) 2℃, f=10kHz	480
		H=1200(A/m) 100℃ , f=10kHz	390
H _c	A/m	25℃ f=10kHz	13
		100℃ f=10kHz	10
Br _{ms}	mT	H=1200(A/m) 2℃, f=10kHz	140
T _c	℃	-	> 210
f _c	MHz	25℃	1.5
P _L	mW/Cm ³	200mT 25℃ f=100kHz	700
		200mT 100℃ f=100kHz	410
p	Ω . m	-	7
d	g/Cm ³	-	4.80x10 ³

NO	REVISION	DATE	CHECK	DRAWN	CHECKED	APPROVED
1						
2						
3						
4						

0705-00양식04

DONG HEUNG ELECTRONICS CO., LTD.

CUSTOMER : GREEN C&C CO., LTD.

<h1>SPECIFICATION</h1>		SHEET NO.	
		D A T E	2005. 04. 21.
PART NAME	INVERTER TRANS	MODEL NAME	
PART NO.	GT-209	DESCRIPTION	EFD18x20 (EEA17.7mm)

Symbol	UNIT	TEMP	YP-2
Initial permeability (μ_{iac})			2500±25%
Core Loss(Pcv) [100kHz,200mT]	kW/m ³	23℃	600
		60℃	430
		80℃	400
		100℃	4400
Saturation magnetic flux density(Bs) [H=1194A/m]	mT	23℃	510
		100℃	400
Remanent flux density(Br) [H=1194A/m]	mT	23℃	60
		100℃	40
Coercive force(Hc)	A/m	23℃	5.5
		100℃	-
Relative Loss factor (tanδ/μi)	x10 ⁻⁶		2.9
Curie temperature(TC)	℃		>220
Electrical resistivity	Ω . m		6
Density(d)	Kg/m ³		4.8 x 10 ³

NO	REVISION	DATE	CHECK	DRAWN	CHECKED	APPROVED
1						
2						
3						
4						

CUSTOMER : GREEN C&C CO., LTD.

<h1>SPECIFICATION</h1>		SHEET NO.	
		D A T E	2005. 04. 21.
PART NAME	INVERTER TRANS	MODEL NAME	
PART NO.	GT-209	DESCRIPTION	EFD18x20 (EEA17.7mm)

* BOBBIN SIZE (Unit:mm)

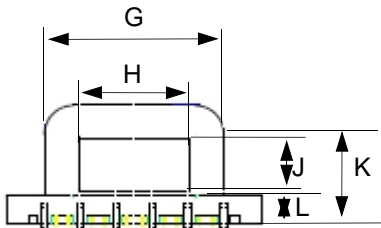
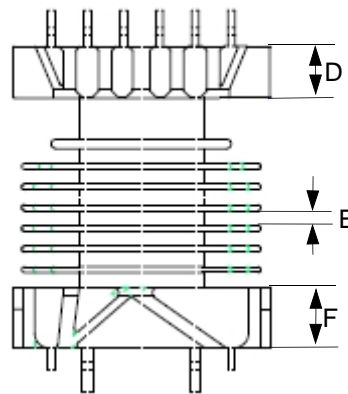
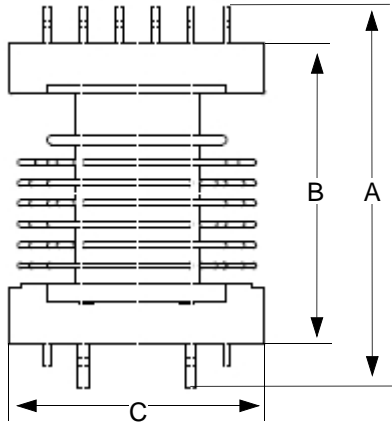

** Sn : 4um MIN

** Ni : 1um MIN

	A	B	C	D	E	F	G	H	J	K	L
SPEC	26.5 ±0.20	21.0 ±0.20	17.8 ±0.20	3.6 ±0.20	1.04 ±0.20	4.2 ±0.20	12.5 ±0.20	7.7 ±0.20	3.6 ±0.20	8.2 ±0.20	2.3 ±0.20
1	26.56	21.02	17.85	3.66	1.04	4.21	12.46	7.69	3.60	8.17	2.34
2	26.59	21.02	17.87	3.69	1.04	4.21	12.48	7.68	3.60	8.16	2.33
3	26.58	21.01	17.88	3.65	1.04	4.20	12.47	7.68	3.60	8.15	2.34
4	26.58	21.00	17.86	3.68	1.04	4.21	12.48	7.69	3.61	8.15	2.32
5	31.77	27.42	17.87	3.65	1.04	4.20	12.48	7.68	3.59	8.16	2.33

NO	REVISION	DATE	CHECK	DRAWN	CHECKED	APPROVED
1						
2						
3						
4						

CUSTOMER : GREEN C&C CO., LTD.

SPECIFICATION		SHEET NO.	
		D A T E	2005. 04. 21.
PART NAME	INVERTER TRANS	MODEL NAME	
PART NO.	GT-209	DESCRIPTION	EFD18x20 (EEA17.7mm)

ITEM	BOBBIN	WIRE	POLYESTER TAPE
STANDARD	94V-0	130℃	130℃
1	OK	OK	OK
2	OK	OK	OK
3	OK	OK	OK
4	OK	OK	OK
5	OK	OK	OK
6	OK	OK	OK
7	OK	OK	OK
8	OK	OK	OK
9	OK	OK	OK
10	OK	OK	OK

NO	REVISION	DATE	CHECK	DRAWN	CHECKED	APPROVED
1						
2						
3						
4						