



### 5.0A LOW DROPOUT PRECISION LINEAR REGULATORS

#### Description

GL1084 series of positive adjustable and fixed regulators is designed to provide 5A output with low dropout voltage performance. On-chip trimming adjusts the reference voltage with an accuracy of 1% for adjustable, and 2% for fixed voltage versions. To work in post regulators or microprocessor power supplies, which where low voltage operation and fast transient response are required. Device includes over-current protection and thermal shutdown protection as well.

GL1084 is available in TO-220 and surface-mount TO-263 & TO-252 packages.

#### Features

- ◆ Adjustable or Fixed Output
- ◆ Output Current of 5.0A
- ◆ Dropout Voltage (max.) 1.5V @ 5.0A
- ◆ Typical Line Regulation 0.04%
- ◆ Typical Load Regulation 0.2%
- ◆ Fast Transient Response
- ◆ Current Limit Protection
- ◆ Thermal Shutdown Protection

#### Application

Microprocessor Supply

Post Regulators for Switching Supplies

Telecommunication Systems

Medical Equipment

Printer Supplies

Motherboards

#### TYPICAL APPLICATION CIRCUITS

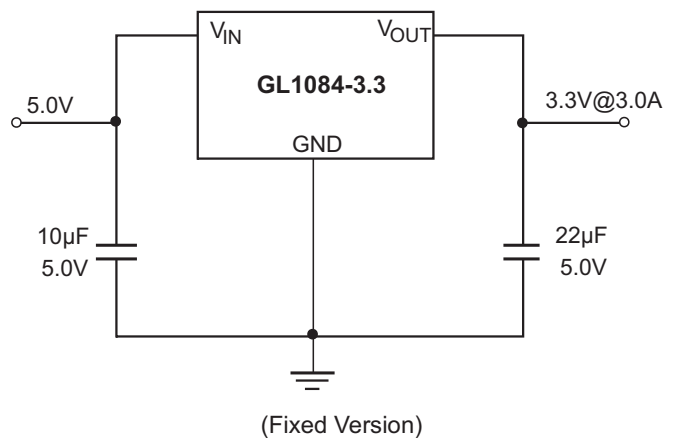
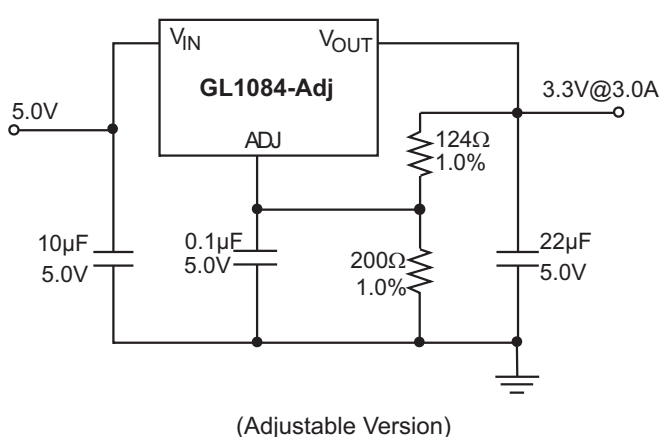

#### ◆ MARKING INFORMATION & PIN CONFIGURATIONS (Top View)

TO-220

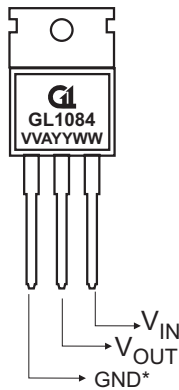

TO-263-2 (D<sup>2</sup>PAK)

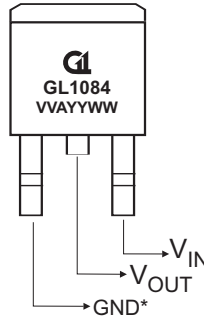

TO-252-2 (DPAK)

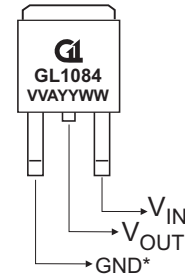

V V = Output Voltage (50 = 5.0V, A =Adj)  
 A = Assembly Location  
 YY = Year  
 W W = Weekly

\* On fixed versions Pin 1 = GND,  
 on adjustable versions Pin 1 = ADJ  
 \* Tab = V<sub>OUT</sub>

#### ◆ ORDERING INFORMATION (Green Package Products are available now!)

Ordering Number	Output Voltage	Package	Shipping
GL1084-ATA3T	Adj	TO-263-2	50 Units / Tube
GL1084-ATA3R	Adj	TO-263-2	800 Units / Tape & Reel
GL1084-ATB3T	Adj	TO-220	50 Units / Tube
GL1084-ATC3R	Adj	TO-252-2	2,500 Units / Tape & Reel
GL1084-1.8TA3T	1.8	TO-263-2	50 Units / Tube
GL1084-1.8TA3R	1.8	TO-263-2	800 Units / Tape & Reel
GL1084-1.8TB3T	1.8	TO-220	50 Units / Tube
GL1084-1.8TC3R	1.8	TO-252-2	2,500 Units / Tape & Reel
GL1084-2.5TA3T	2.5	TO-263-2	50 Units / Tube
GL1084-2.5TA3R	2.5	TO-263-2	800 Units / Tape & Reel
GL1084-2.5TB3T	2.5	TO-220	50 Units / Tube
GL1084-2.5TC3R	2.5	TO-252-2	2,500 Units / Tape & Reel
GL1084-3.3TA3T	3.3	TO-263-2	50 Units / Tube
GL1084-3.3TA3R	3.3	TO-263-2	800 Units / Tape & Reel
GL1084-3.3TB3T	3.3	TO-220	50 Units / Tube
GL1084-3.3TC3R	3.3	TO-252-2	2,500 Units / Tape & Reel
GL1084-5.0TA3T	5.0	TO-263-2	50 Units / Tube
GL1084-5.0TA3R	5.0	TO-263-2	800 Units / Tape & Reel
GL1084-5.0TB3T	5.0	TO-220	50 Units / Tube
GL1084-5.0TC3R	5.0	TO-252-2	2,500 Units / Tape & Reel

\* For detail ordering number identification, please see last page.

#### ◆ ABSOLUTE MAXIMUM RATINGS

PARAMETER	SYMBOL	VALUE	UNIT
Power Dissipation	$P_D$	Internally limited	W
Input Voltage	$V_{IN}$	15	V
Junction Temperature	$T_J$	+150	°C
Lead Temperature(Soldering, 10sec)	$T_{LEAD}$	300	°C
Operating Junction Temperature Range	$T_J$	-20 to + 125	°C
Storage Temperature Range	$T_{STG}$	-65 to + 150	°C

#### ◆ BLOCK DIAGRAM

(Fixed Version)

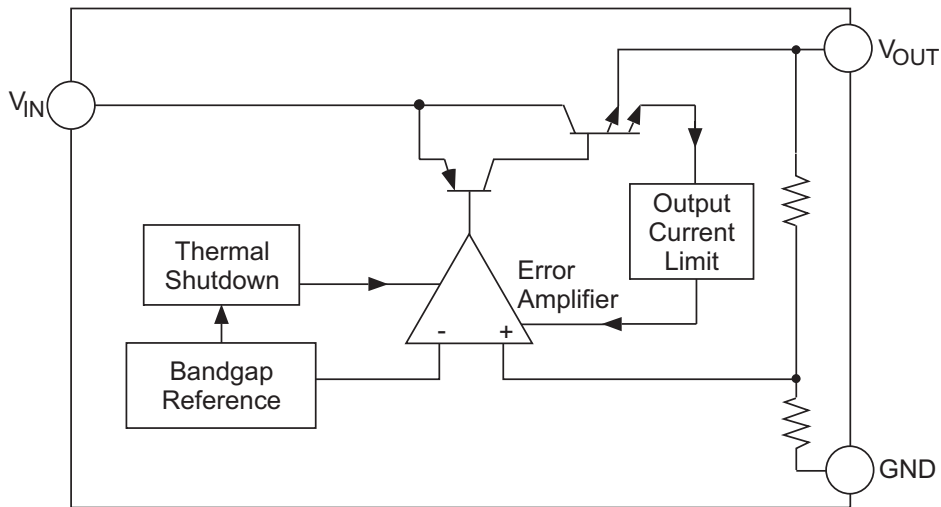

(Adjustable Version)

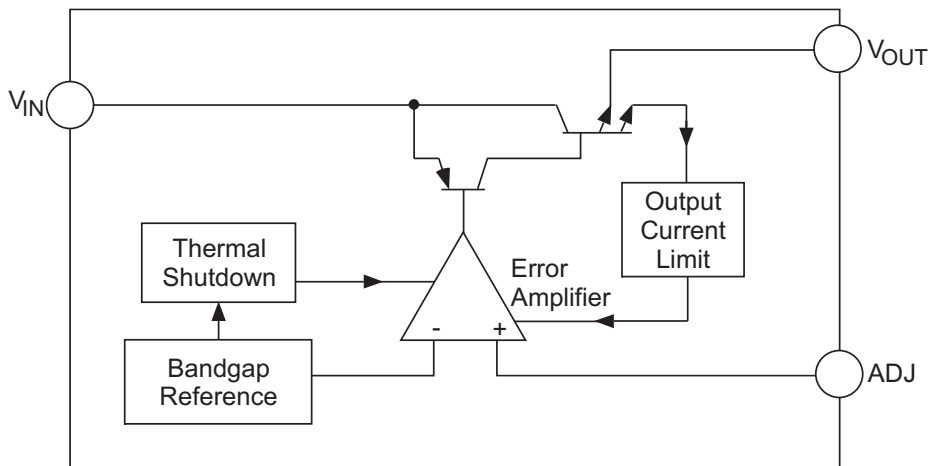



5.0A LOW DROPOUT PRECISION LINEAR REGULATORS

◆ ELECTRICAL CHARACTERISTICS

(Typicals and limits appearing in normal type apply for  $T_J = 25^\circ\text{C}$ )

Parameter		Symbol	Condition	Min	Typ	Max	Unit
Reference Voltage	GL1084-Adj	$V_{REF}$	$I_{OUT}=10\text{mA}, V_{IN}-V_{OUT}=1.5\text{V}$	1.238	1.250	1.262	V
			$10\text{mA} \leq I_{OUT} \leq 5\text{A}, 3.3\text{V} \leq V_{IN} \leq 11.25\text{V}$	1.230	1.250	1.270	
Output Voltage	GL1084-1.8	$V_O$	$I_{OUT}=10\text{mA}, V_{IN}=3.3\text{V}$	1.782	1.800	1.818	V
			$10\text{mA} \leq I_{OUT} \leq 5\text{A}, 3.3\text{V} \leq V_{IN} \leq 11.8\text{V}$	1.764	1.800	1.836	
	GL1084-2.5		$I_{OUT}=10\text{mA}, V_{IN}=4\text{V}$	2.475	2.500	2.525	V
			$10\text{mA} \leq I_{OUT} \leq 5\text{A}, 4\text{V} \leq V_{IN} \leq 12.5\text{V}$	2.460	2.500	2.540	
	GL1084-3.3		$I_{OUT}=10\text{mA}, V_{IN}=4.8\text{V}$	3.267	3.300	3.333	V
	$10\text{mA} \leq I_{OUT} \leq 5\text{A}, 4.8\text{V} \leq V_{IN} \leq 13.3\text{V}$	3.247	3.300	3.353			
GL1084-5.0	$I_{OUT}=10\text{mA}, V_{IN}=6.5\text{V}$	4.950	5.000	5.050	V		
	$10\text{mA} \leq I_{OUT} \leq 5\text{A}, 6.5\text{V} \leq V_{IN} \leq 15\text{V}$	4.920	5.000	5.080			
Line Regulation	GL1084-Adj	$REG_{LINE}$	$I_{OUT}=10\text{mA}$ ,		0.04	0.20	%
	GL1084-1.8		$I_{OUT}=10\text{mA}, 3.3\text{V} \leq V_{IN} \leq 11.8\text{V}$		0.04	0.20	
	GL1084-2.5		$I_{OUT}=10\text{mA}, 4\text{V} \leq V_{IN} \leq 12.5\text{V}$		0.04	0.20	
	GL1084-3.3		$I_{OUT}=10\text{mA}, 4.8\text{V} \leq V_{IN} \leq 13.3\text{V}$		0.04	0.20	
	GL1084-5.0		$I_{OUT}=10\text{mA}, 6.5\text{V} \leq V_{IN} \leq 15\text{V}$		0.04	0.20	
Load Regulation	GL1084-Adj	$REG_{LOAD}$	$V_{IN}-V_{OUT}=1.5\text{V}, 10\text{mA} \leq I_O \leq 5\text{A}$		0.2	0.40	%
	GL1084-1.8		$V_{IN}=3.3\text{V}, 10\text{mA} \leq I_O \leq 5\text{A}$		0.2	0.40	
	GL1084-2.5		$V_{IN}=4\text{V}, 10\text{mA} \leq I_O \leq 5\text{A}$		0.2	0.40	
	GL1084-3.3		$V_{IN}=4.8\text{V}, 10\text{mA} \leq I_O \leq 5\text{A}$		0.2	0.40	
	GL1084-5.0		$V_{IN}=6.5\text{V}, 10\text{mA} \leq I_O \leq 5\text{A}$		0.2	0.40	
Dropout Voltage		$V_D$	$I_{OUT}=5\text{A}$		1.3	1.5	V
Current Limit		$I_{CL}$	$V_{IN}-V_{OUT}=1.5\text{V}$	5	6.5		A
Minimum Load Current	GL1084-Adj	$I_{O\ MIN}$	$V_{IN}=5\text{V}$		7	10	mA
Quiescent Current	GL1084-1.8	$I_Q$	$V_{IN}=3.3\text{V}, 10\text{mA} \leq I_O \leq 5\text{A}$		7	10	mA
	GL1084-2.5		$V_{IN}=4.0\text{V}, 10\text{mA} \leq I_O \leq 5\text{A}$		7	10	
	GL1084-3.3		$V_{IN}=4.8\text{V}, 10\text{mA} \leq I_O \leq 5\text{A}$		7	10	
	GL1084-5.0		$V_{IN}=6.5\text{V}, 10\text{mA} \leq I_O \leq 5\text{A}$		7	10	
Adjust Pin Current	GL1084-Adj	$I_{ADJ}$	$I_{OUT}=10\text{mA}, 2.75\text{V} \leq V_{IN} \leq 11.25\text{V}$		40	90	mA
Temperature Coefficient			$V_{IN}-V_{OUT}=1.5\text{V}, I_{OUT}=10\text{mA}$		0.005		%/ $^\circ\text{C}$
Ripple Rejection		$R_A$	$V_{IN}-V_{OUT}=1.5\text{V}, I_{OUT}=5\text{A}$	60	72		dB

#### ◆ APPLICATION INFORMATION

GL1084 series linear regulators provide fixed and adjustable output voltages at currents up to 5.0A. These regulators are protected against over-current conditions and include thermal shutdown protection. The GL1084 has a composite PNP-NPN output transistor and require an output capacitor for stability.

A detailed procedure for selecting this capacitor is as followed.

#### Stability Considerations

The output compensation capacitor helps to determine three main characteristics of a linear regulator's performance: start-up delay, load transient response, and loop stability. The capacitor value and type is based on cost, availability, size, and temperature constraints. A tantalum or aluminum electrolytic capacitor is preferred, as a film or ceramic capacitor with almost zero ESR can cause instability. An aluminum electrolytic capacitor is the least expensive type. But when the circuit operates at low temperatures, both the value and ESR of the capacitor will vary widely. For optimum performance over the full operating temperature range, a tantalum capacitor is the best. A 22 $\mu$ F tantalum capacitor will work fine in most applications. But with high current regulators, such as GL1084 higher capacitance values will improve the transient response and stability. Most applications for GL1084 involve large changes in load current, so the output capacitor must supply instantaneous load current. The ESR of the output capacitor causes an immediate drop in output voltage given by:

$$\Delta V = \Delta I \times ESR$$

In microprocessor applications an output capacitor network of several tantalum and ceramic capacitors in parallel is commonly used. This reduces overall ESR and minimizes the instantaneous output voltage drop under transient load conditions. The output capacitor network should be placed as close to the load as possible for the best results.

#### Protection Diodes

When large external capacitors are used with most linear regulator, it is wise to add protection diodes. If the input voltage of the regulator is shorted, the output capacitor will discharge into the output of the regulator. The discharge current depends on the value of capacitor, output voltage, and rate at which  $V_{IN}$  drops.

Figure 1 <sup>(a),(b)</sup> Protection Diode Scheme for Large Output Capacitors

#### (a) Fixed Version

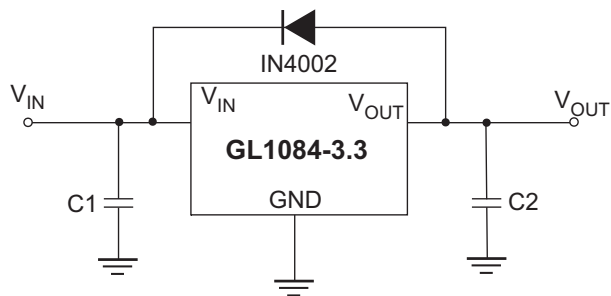

#### (B) Adjustable Version

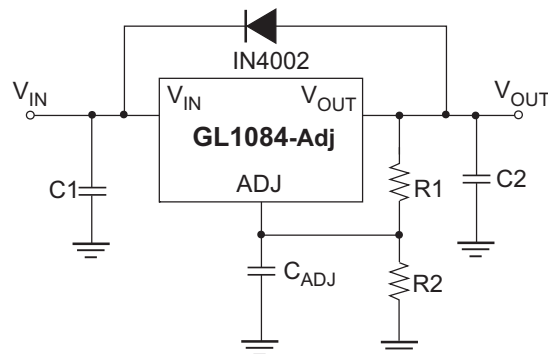

In GL1084 linear regulators, the discharge path is through a large junction, and protection diodes are normally not needed. However, if the regulator is used with large output capacitance values and the input voltage is instantaneously shorted to ground, damage can occur. In this case, a diode connected as shown above in Figure 1.

#### Output Voltage Sensing

GL1084 series is three terminal regulator, so they cannot provide true remote load sensing. Load regulation is limited by the resistance of the conductors connecting the regulator to the load. For best results, GL1084 should be connected as shown in Figure 2.

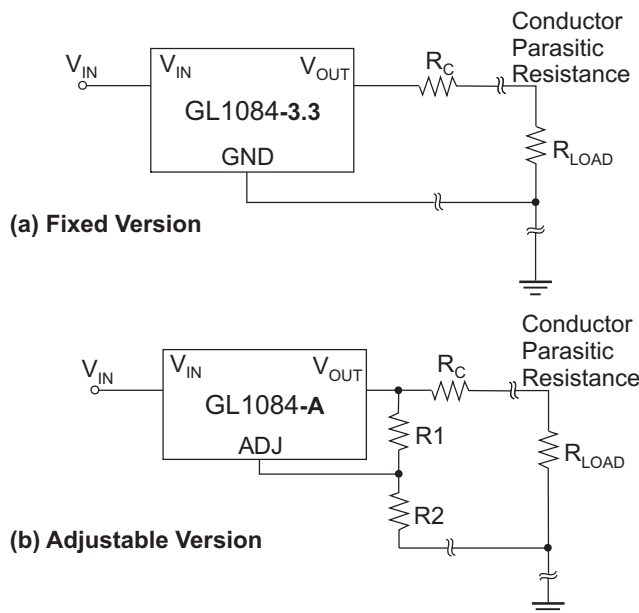

Figure 2 (a),(b) Conductor Parasitic Resistance Effects are Minimized by this Grounding Scheme For Fixed and Adjustable Output Regulators

#### Calculating Power Dissipation and Heat Sink Requirements

GL1084 series precision linear regulators include thermal shutdown and current limit circuitry to protect the devices. However, high power regulators normally operate at high junction temperatures so it is important to calculate the power dissipation and junction temperatures accurately to be sure that you use an adequate heat sink. The case is connected to  $V_{OUT}$  on GL1084. so electrical isolation may be required for some applications. Thermal compound should always be used with high current regulators like GL1084.

The thermal characteristics of an IC depend on four factors:

1. Maximum Ambient Temperature  $T_A$  ( $^{\circ}C$ )
2. Power Dissipation  $P_D$  (Watts)
3. Maximum Junction Temperature  $T_J$  ( $^{\circ}C$ )
4. Thermal Resistance Junction to ambient  $R_{\theta JA}$  ( $^{\circ}C/W$ )

These relationship of these four factors is expressed by equation (1):

$$T_J = T_A + P_D \times R_{\theta JA} \dots\dots(1)$$

Maximum ambient temperature and power dissipation are determined by the design while the maximum junction temperature and thermal resistance depend on the manufacturer and the package type.

The maximum power dissipation for a regulator is expressed by equation (2):

$$P_{D(max)} = \{ V_{IN(max)} - V_{OUT(min)} \} I_{OUT(max)} + V_{IN(max)} I_Q \dots\dots(2)$$

where:  
 $V_{IN(max)}$  is the maximum input voltage,  
 $V_{OUT(min)}$  is the minimum output voltage,  
 $I_{OUT(max)}$  is the maximum output current  
 $I_Q$  is the maximum quiescent current at  $I_{OUT(max)}$ .

A heat sink effectively increases the surface area of the package to improve the flow of heat away from the IC into the air. Each material in the heat flow path between the IC and the environment has a thermal resistance. Like series electrical resistances, these resistances are summed to determine  $R_{\theta JA}$ , the total thermal resistance between the junction and the air. This is expressed by equation (3):

$$R_{\theta JA} = R_{\theta JC} + R_{\theta CS} + R_{\theta SA} \dots\dots(3)$$

Where all of the following are in  $^{\circ}C/W$ :  
 $R_{\theta JC}$  is thermal resistance of junction to case,  
 $R_{\theta CS}$  is thermal resistance of case to heat sink,  
 $R_{\theta SA}$  is thermal resistance of heat sink to ambient air

The value for  $R_{\theta JA}$  is calculated using equation (3) and the result can be substituted in equation(1). The value for  $R_{\theta JC}$  is  $3.5^{\circ}C/W$  for a given package type based on an average die size. For a high current regulator such as GL1084, the majority of the heat is generated in the power transistor section.

◆ Typical Performance Characteristics

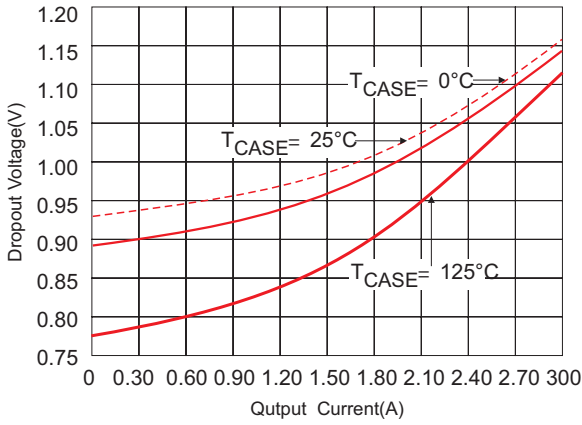

Figure 3. Dropout Voltage vs. Output Current

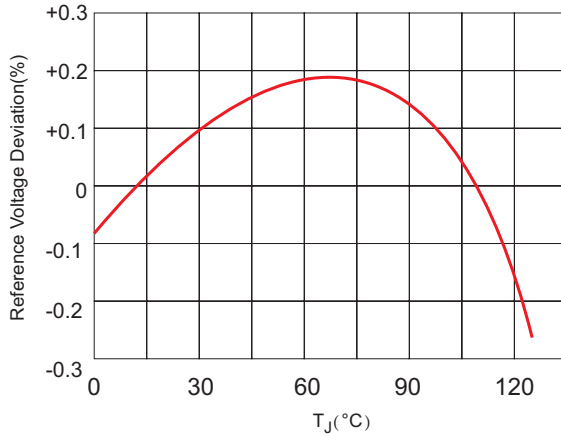

Figure 4. Bandgap Reference Voltage Deviation vs. Temperature

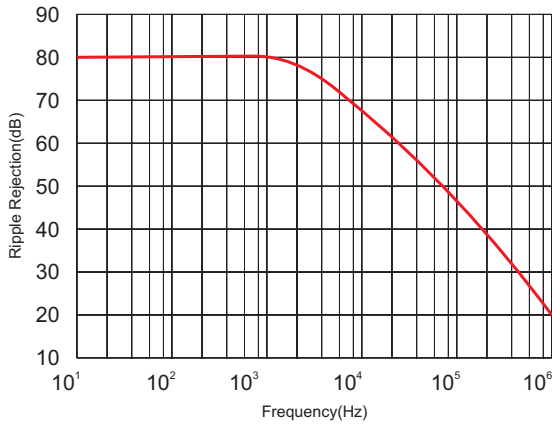

Figure 5. Ripple Rejection vs. Frequency

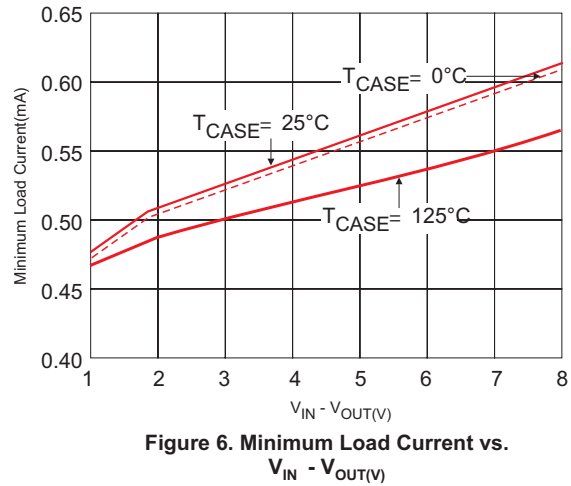
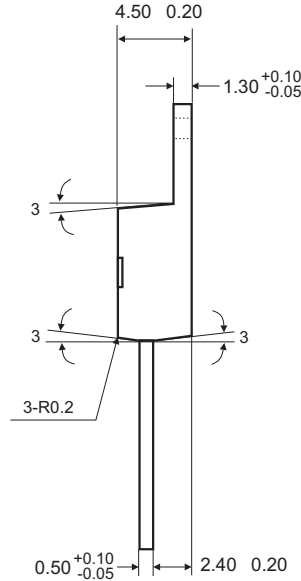
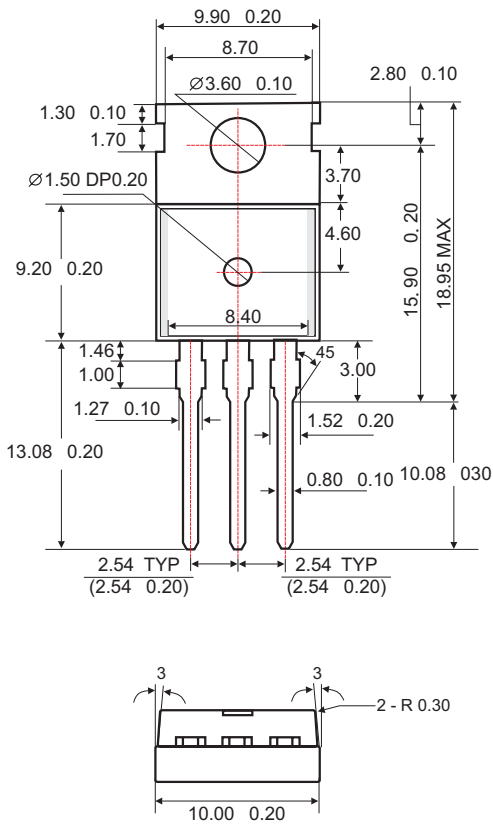

Figure 6. Minimum Load Current vs.  $V_{IN} - V_{OUT}$

5.0A LOW DROPOUT PRECISION LINEAR REGULATORS

◆ TO-220 PACKAGE OUTLINE DIMENSIONS



Unit: mm

◆ TO-263-2 PACKAGE OUTLINE DIMENSIONS

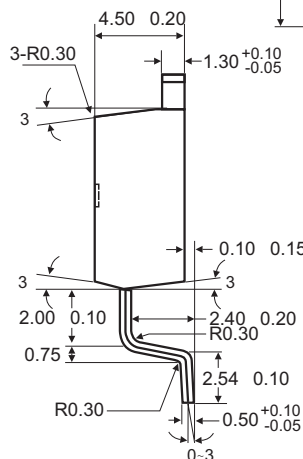
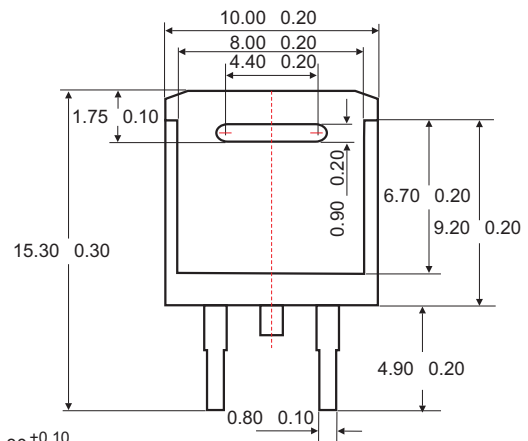
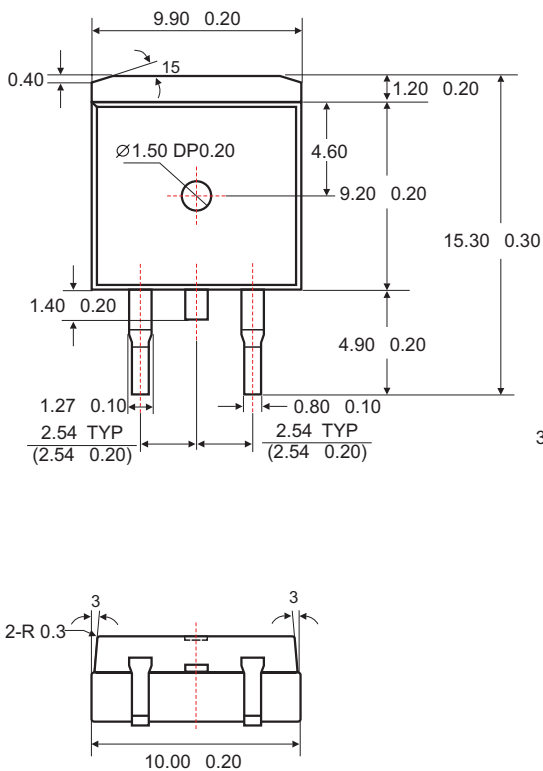

Unit: mm



#### ◆ TO-252-3 PACKAGE OUTLINE DIMENSIONS

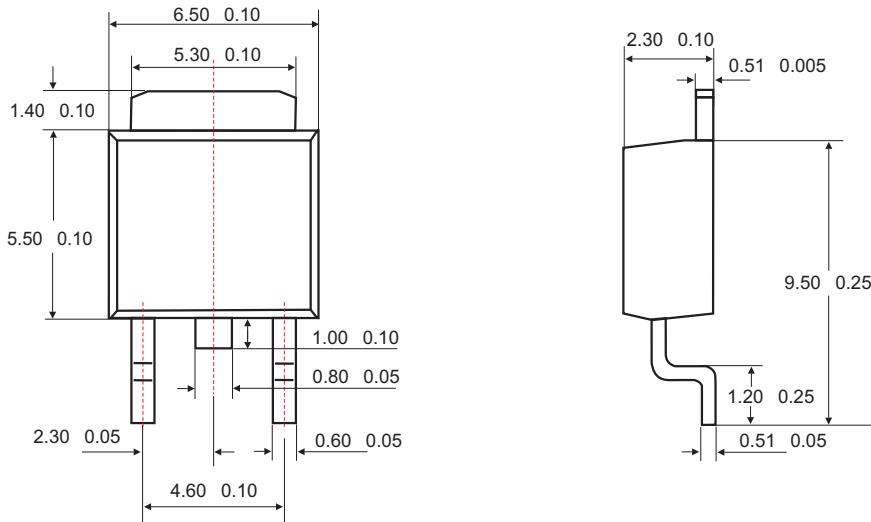

Unit: mm

#### ◆ ORDERING NUMBER

