

Description

The GL1162 is a very high frequency video amplifier system intended for use in high resolution RGB monitor applications.

In addition to the three matched video amplifiers, the GL1162 contains three gated single ended input black level clamp comparators for brightness control, three matched DC controlled attenuators for brightness control, three matched DC controlled attenuators for contrast control, and three DC controlled sub-contrast attenuators providing gain trim capability for white balance. All DC control inputs offer high input impedance and an operation range from 0V to 4V for easy interface to bus controlled alignment systems.

The GL1162 also contains a blanking circuit which clamps the video output voltage during blanking to within 0.1V of ground. This feature provides blanking capability at the cathode of the CRT.

Pin Configuration

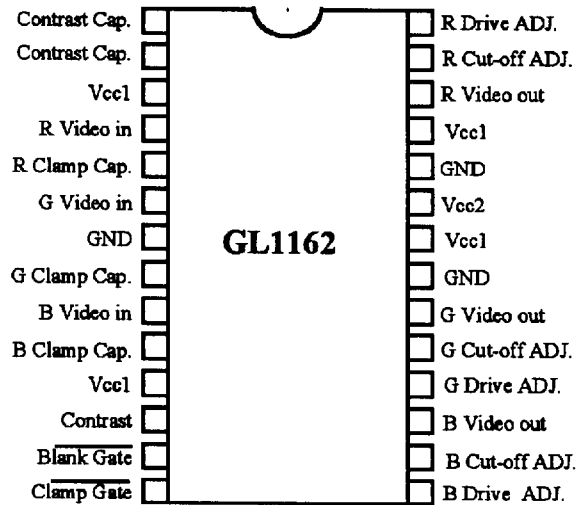

Feature

- Three wideband video amplifiers (130MHz , -3dB)
- Matched (± 0.1 dB) attenuators for contrast control.
- Three externally gated single ended input comparators for cutoff and brightness control.
- Provisions for individual gain control (drive) of each video amplifier.
- 0V to 4V , high input impedance DC contrast control (> 40 dB range)
- 0V to 4V , high input impedance DC drive control (± 3 dB range)
- Capable of 7 Vpp output swing (slight reduction in bandwidth)
- Output stage blanking
- Output stage directly drives most hybrid or discrete CRT drivers.

Application

High Resolution RGB color monitor

Operating Conditions(*4)

SYMBOL	PARAMETER	RATINGS	UNIT
T _{OPR}	Temperature range	-20 to 80	°C
V _{CC}	Supply voltage	10.8 ≤ V _{CC} ≤ 13.2	V

Block Diagram

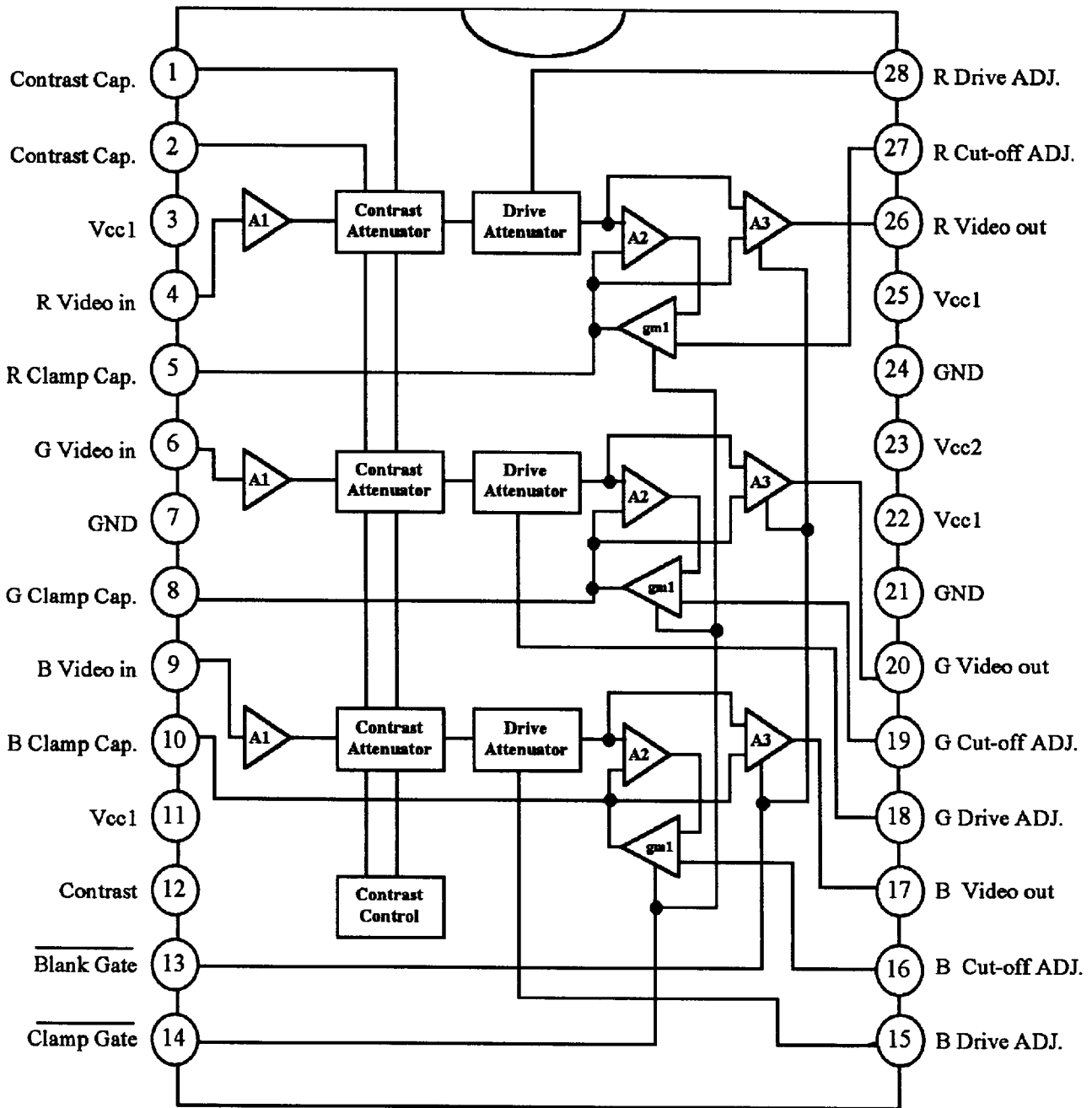

Absolute Maximum Ratings(*1)

SYMBOL	PARAMETER	RATINGS	UNIT
V _{CC}	Supply Voltage pins 3 , 11 , 22 , 23 , 25 (*2)	13.5	V
I _{CC}	Peak Video Output Source Current (any one amp) Pins 17 , 20 or 26	28	mA
V _{IN}	Voltage at any Input Pin	V _{CC} ≥ V _{IN} ≥ GND	V
P _D	Power Dissipation (above 25°C derate based on θ _{ja} and θ _j)	2.5	W
ESD	ESD Susceptibility(*3)	2	V
θ _{ja}	Thermal Resistance	50	°C/W
T _j	Junction Temperature	150	°C
T _L	Lead Temperature (Soldering , 10sec.)	265	°C

Electrical Characteristics

1) DC Characteristics : V_{cc1}=V_{cc2}=12V , T_a=25°C , V_{I2}=4V , V_{I4}=0V , V_{cut-off}=1.0V
V_{I3}=4V , V_{drive}=4V unless otherwise stated

ITEM	SYMBOL	CONDITIONS	MIN	TYP	MAX	Unit
Supply Current	I _s	V _{cc1} +V _{cc2} , R _L =∞ (*7)	-	90	105	mA
Video Amp. Input Bias Voltage	V _{4,6,9}		-	2.8	-	V
Video Input Resistance	R _{IN}	Any one Amp.	-	20	-	kΩ
Clamp Gate Low Input Voltage	V _{14,L}	Clamp Comparators on	0.8	1.2	-	V
Clamp Gate High Input Voltage	V _{14,H}	Clamp Comparators off	-	1.6	2.0	V
Clamp Gate Low Input Current	I _{14,L}	V ₁₄ =0V	-5.0	-1	-	uA
Clamp Gate High Input Current	I _{14,H}	V ₁₄ =12V	-	0.01	1.0	uA
Clamp Capacitor Charge Current	I _{clamp}	Clamp Comparators on	± 500	± 750	-	uA
Clamp Cap Bias Discharge Current	I _{bias}	Clamp Comparators off	-	500	-	nA
Blank Gate Low Input Voltage	V _{13,L}	Blank Gate on	0.8	1.2	-	V
Blank Gate High Input Voltage	V _{13,H}	Blank Gate off	-	1.6	2.0	V

ITEM	SYMBOL	CONDITIONS	MIN	TYP	MAX	UNIT
Blank Gate Low Input Current	I13,L	V13=0V	-5.0	-1	-	uA
Blank Gate High Input Current	I13,H	V13=12V	-	0.01	1.0	uA
Video Output Low Voltage	V _{OL}	V _{out-off} =0V	-	0.15	0.5	V
Video Output High Voltage	V _{OH}	V _{out-off} =9V	7.0	7.5	-	V
Video Black Level Output Voltage	V _O (1V)	V _{out-off} =1V	-	0.9	-	V (*8)
Video ΔBlack Level Output Voltage	ΔV _O (1V)	Between any Two Amps, V _{out-off} =1V	-	±100	-	mV
Video Output Blanked Voltage	V _{OL} (blanked)	V13=0V	-	35	70	mV
Contrast / Drive Control Input Current	I12,15,18 or 28	V _{contrast} =V _{drive} =0V to 4V	-	-250	-	nA
Cut-off Control Input Current (all inputs)	I16,19 and 27	V _{out-off} =0V to 4V	-	-500	-	nA

2) AC Characteristics : V_{cc1}=V_{cc2}=12V , T_a=25°C ; Manually adjust video output pins 17, 20, and 26 to 4V DC for the AC test unless otherwise stated. (*15)

ITEM	SYMBOL	CONDITIONS	MIN	TYP	MAX	UNIT
Video Amplifier Gain	A _v , max	V12=4V, V _{IN} =635mVpp V _{drive} =4V	5.4 14.6	7.0 16.9	- -	V/V dB
Attenuation at V12=2V	Δ A _v , 2V	ref : A _{vmax} , V12=2V	-	-6	-	dB
Attenuation at V12=0.5V	Δ A _v , 0.5V	rdf : A _{vmax} , V12=0.5V	-	-38	-	dB
Drive Control Range	Δ Drive	V _{drive} =0V to 4V V12=4V	-	6	-	dB
Absolute Gain Match at A _{vmax}	A _v , match	V12=4V, V _{drive} =4V (*9)	-	±0.3	-	dB
Gain Change Between Amplifiers	A _v , track1	V12=4V to 2V (*9, *10)	-	±0.1	-	dB
Video Amplifier Distortion	THD	V _O =1Vpp, f=10KHz	-	1	1.0	%
Video Amplifier Bandwidth (*11, *12)	f(-3dB)	V12=4V, V _{drive} =4V V _O =4Vpp	-	130	-	MHz
Video Output Rise Time (*11)	tr(video)	V _O =4Vpp	-	2.6	-	nS
Video Output Fall Time (*11)	tf(video)	V _O =4Vpp	-	3.6	-	nS
Video Amplifier 10KHZ Isolation	V _{sep} (10KHZ)	V12=4V (*13)	-	-70	-	dB
Video Amplifier 10MHZ Isolation	V _{sep} (10MHZ)	V12=4V (*11, *13)	-	-50	-	dB

ITEM	SYMBOL	CONDITIONS	MIN	TYP	MAX	UNIT
Blank Output Rise Time (*11)	tr(blank)	Blank Output=1Vpp	-	7	-	nS
Blank Ooutput Fall Time (*11)	tf(blank)	Blank Output=1Vpp	-	7	-	nS
Back Porch Clamp Pulse Width	twp (clamp)				(*14)	nS

(NOTE)

- *1 : Stresses above those listed under "Absolute Maximum Ratings" may cause permanent damage of the device. This is a stress rating only and functional operation of the device at these or any other conditions above those indicated in the operational sections of this specification is not implied. Exposure to absolute maximum rating conditions for longer periods may affect device reliability. During overload conditions ($V_{IN} > V_{CC}$ or $V_{IN} < GND$), the voltage on V_{CC} pins with respect to ground must not exceed the values defined by the absolute maximum ratings.
- *2 : V_{CC} supply pins 3, 11, 22, 23, 25 must be externally wired together to prevent internal damage during V_{CC} power on/off cycles.
- *3 : Human body model, 100pF discharged through a 1.5 k Ω resistor.
- *4 : Operating ratings indicate conditions for which the device is functional, but do not guarantee specific performance limits. For guaranteed specifications and test conditions, see the Electrical Characteristics. The guaranteed specifications apply only for the test conditions listed. Some performance characteristics may degrade when the device is not operated under the listed test conditions.
- *5 : Typical specifications are specified at $\pm 25^{\circ}C$ and represent the most likely parametric norm.
- *6 : Tested limits are guaranteed to National's AOOL (Average Outgoing Quality Level)
- *7 : The supply current specified is the quiescent current for V_{CC1} and V_{CC2} with $R_L = \infty$, see DC test circuit. The supply current for V_{CC2} (pin23) also depends on the output load. With video output at 1V DC, the additional current through V_{CC2} is 8mA for DC test circuit.
- *8 : Output voltage is dependent on load resistor. Test circuit uses $R_L = 390 \Omega$.
- *9 : Measure gain difference between any two amplifiers. $V_{IN} = 63.5mV_{pp}$
- *10 : ΔA_v track is a measure of the ability any two amplifiers to track each other and quantities the matching of the three attenuators. It is the difference in gain change between any two amplifiers with the contrast voltage(V_{12}) at either 4V or 2V measured relative to an A_v max condition, $V_{12} = 4V$. For example, at A_v max the three amplifiers gains might be 17.1dB, 16.9dB and 16.8dB and change to 11.2dB, 10.9dB, and 10.7dB respectively for $V_{12} = 2V$. This yields the measured typical $\pm 0.1dB$ channel tracking.
- *11 : When measuring video amplifier bandwidth or pulse rise and fall times, a double sided full ground plane printed circuit board without socket is recommended. Video amplifier 10MHz isolation test also required this printed circuit board. The reason for a double sided full ground plane PCB is that large measurement variations occur in single sided PCBs.
- *12 : Adjust input frequency from 10MHz (A_v max reference level) to the -3dB corner frequency (f_{-3dB})
- *13 : Measure output levels of the other two undriven amplifiers relative to the driven amplifier to determine channel separation. Terminate the undriven amplifier inputs to simulate generator loading. Repeat test at $f_{IN} = 10MHz$ for $V_{sep} 10MHz$.
- *14 : A minimum pulse width of 200ns is guaranteed for a horizontal line of 15kHz. This limit is guaranteed by design. If a lower line rate is used then a longer clamp pulse may be required.
- *15 : During the AC tests the 4V DC level is the center voltage of the AC output signal. For example, if the output is 4Vpp the signal will swing between 2V DC and 5V DC.

DC Test Circuit

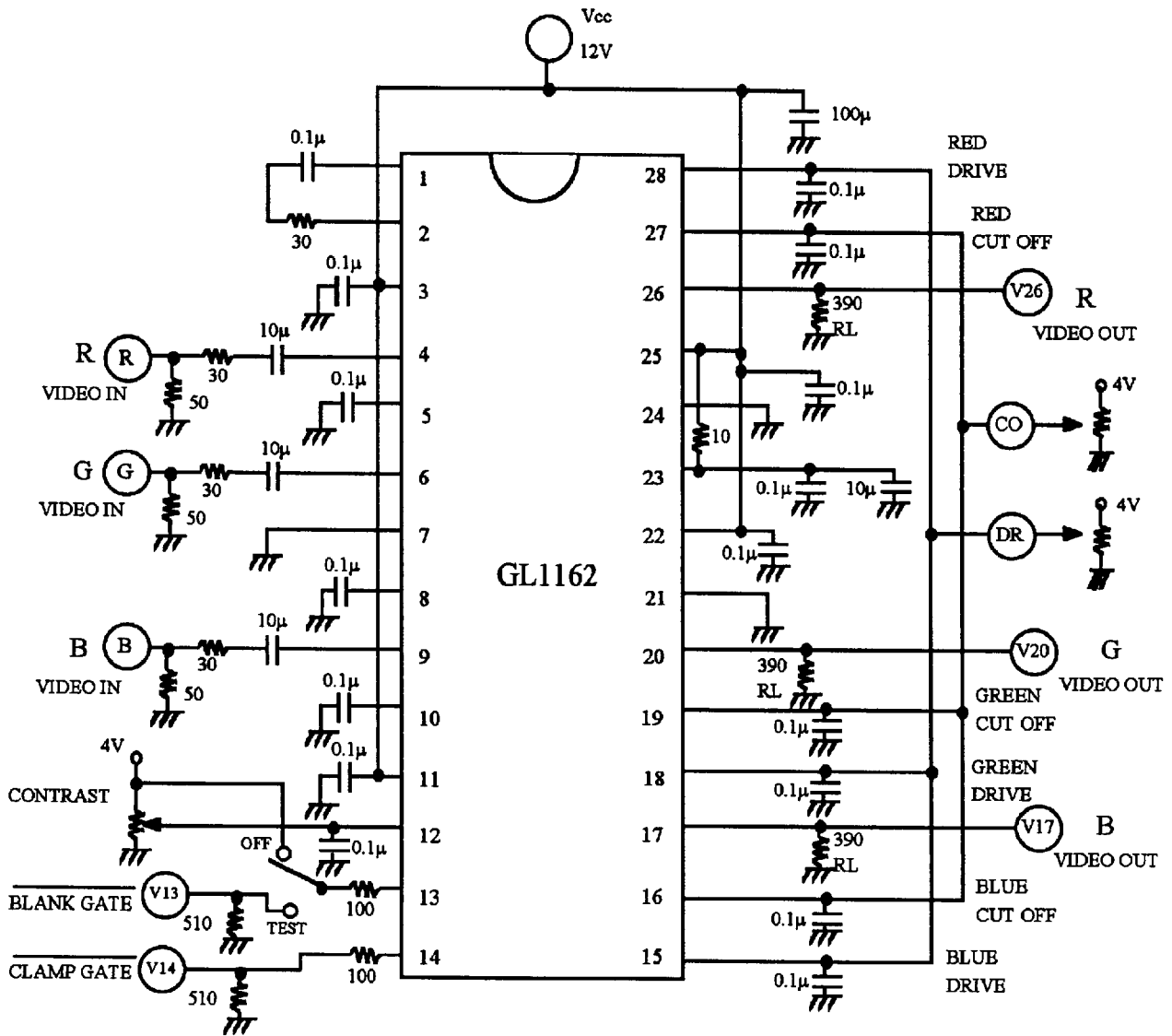

AC Test Circuit

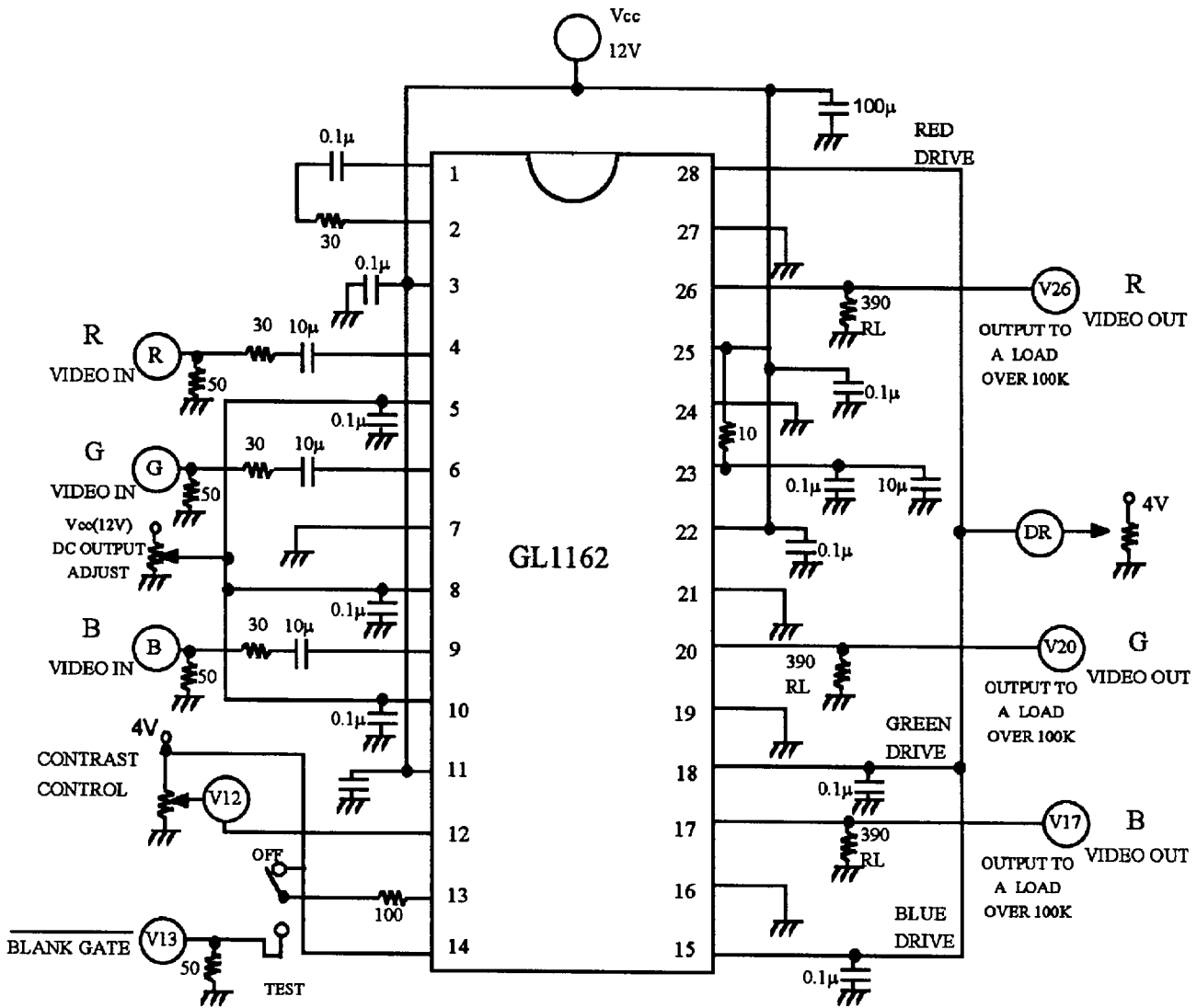

PCB Test Circuit

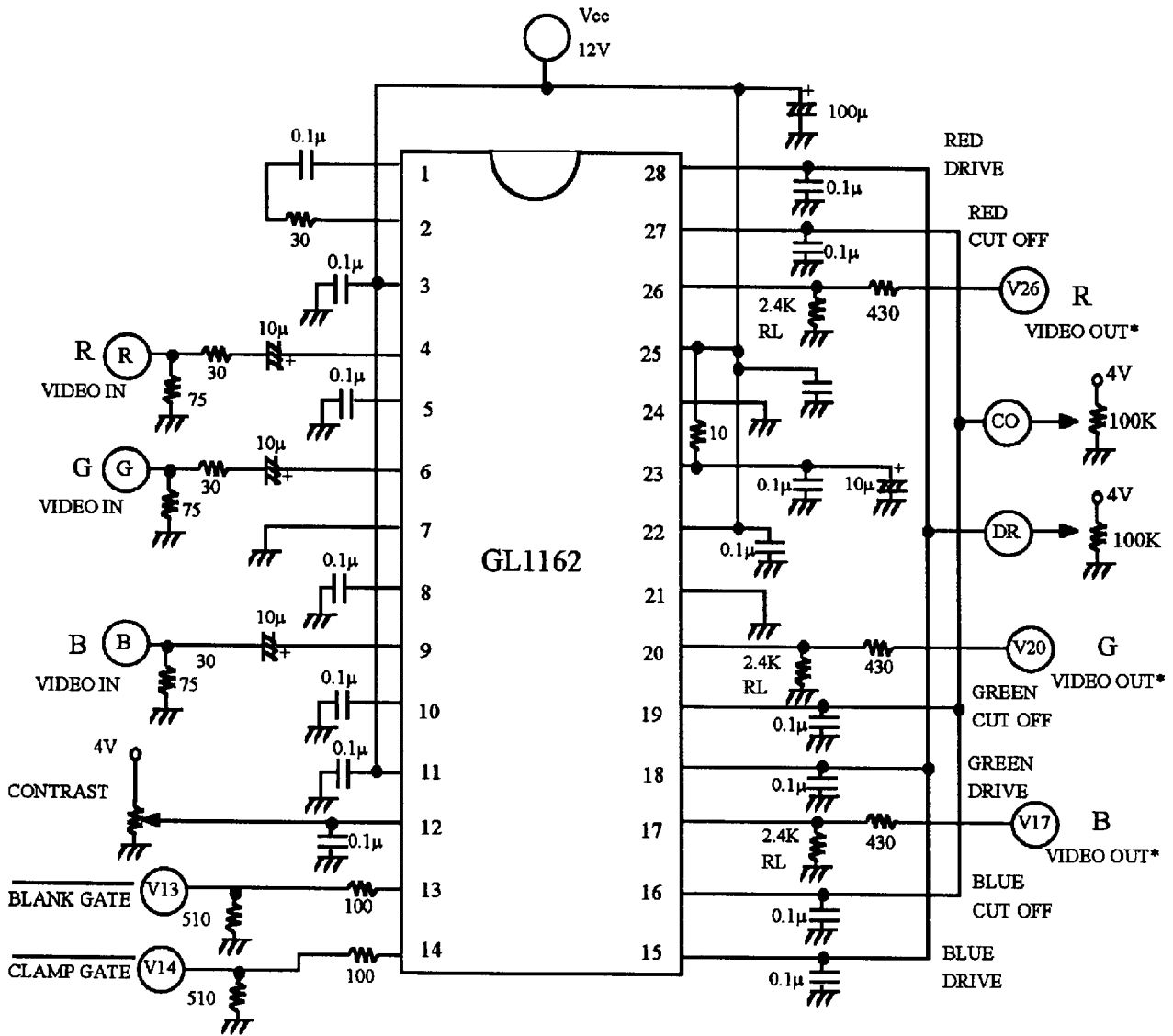

Package Dimension

Unit: Inches (mm)

28 DIP

