



Genesys Logic, Inc.

GL3520M

USB 3.0 Hub Controller

Datasheet

Revision 1.08
Sep. 10, 2012



Copyright

Copyright © 2012 Genesys Logic, Inc. All rights reserved. No part of the materials shall be reproduced in any form or by any means without prior written consent of Genesys Logic, Inc.

Ownership and Title

Genesys Logic, Inc. owns and retains of its right, title and interest in and to all materials provided herein. Genesys Logic, Inc. reserves all rights, including, but not limited to, all patent rights, trademarks, copyrights and any other propriety rights. No license is granted hereunder.

Disclaimer

All Materials are provided “as is”. Genesys Logic, Inc. makes no warranties, express, implied or otherwise, regarding their accuracy, merchantability, fitness for any particular purpose, and non-infringement of intellectual property. In no event shall Genesys Logic, Inc. be liable for any damages, including, without limitation, any direct, indirect, consequential, or incidental damages. The materials may contain errors or omissions. Genesys Logic, Inc. may make changes to the materials or to the products described herein at anytime without notice.

Genesys Logic, Inc.

12F., No. 205, Sec. 3, Beixin Rd., Xindian Dist. 231,
New Taipei City, Taiwan
Tel : (886-2) 8913-1888
Fax : (886-2) 6629-6168
<http://www.genesyslogic.com>

Revision History

Revision	Date	Description
1.00	04/07/2011	First formal release
1.01	04/21/2011	Modify Ch2 Features, p.8
1.02	05/20/2011	Update Package Dimension, p.28
1.03	06/28/2011	Update crystal tolerance range, p.22
1.04	09/26/2011	Update Package Dimension, p.28
1.05	02/16/2012	Support Battery Charging rev. 1.2 Updated CH2 Features, p. 8 Updated Table 7.3 - DC Characteristics except USB Signals, p. 23
1.06	07/09/2012	Modified CH9 Ordering Information, p.29
1.07	07/18/2012	Removed section of AC Characteristics
1.08	09/10/2012	Updated CH7.4 Power Consumption, p.23-24

Table of Contents

CHAPTER 1	GENERAL DESCRIPTION.....	7
CHAPTER 2	FEATURES	8
CHAPTER 3	PIN ASSIGNMENT.....	9
3.1	Pinout.....	9
3.2	Pin Descriptions	10
CHAPTER 4	BLOCK DIAGRAM.....	12
CHAPTER 5	FUNCTION DESCRIPTION	13
5.1	General Description	13
5.1.1	USB 2.0 USPORT Transceiver	13
5.1.2	USB 3.0 USPORT Transceiver	13
5.1.3	PLL (Phase Lock Loop)	13
5.1.4	Regulator	13
5.1.5	SPI Engine	13
5.1.6	RAM/ROM/CPU.....	13
5.1.7	UTMI (USB 2.0 Transceiver Microcell Interface).....	13
5.1.8	SIE (Serial Interface Engine).....	13
5.1.9	Control/Status Register	13
5.1.10	Power Management Engine	13
5.1.11	Router/Aggregator Engine.....	14
5.1.12	REPEATER	14
5.1.13	TT	14
5.1.14	CDP Control Logic	16
5.1.15	USB 3.0/USB 2.0 DSPORT Transceiver	16
5.2	Configuration and I/O Settings	17
5.2.1	RESET Setting	17
5.2.2	SELF/BUS Power Setting	18
5.2.3	LED Connections	18
5.2.4	Power Switch Enable Polarity	18
5.2.5	Port Number Configuration	19
5.2.6	Non-removable Port Configuration	19

CHAPTER 6 USB-IF BATTERY CHARGING SPECIFICATION REV.1.2	
SUPPORT	20
6.1 Background	20
6.2 Charging Downstream Port (CDP).....	20
6.3 Charging Detection Hardware Handshaking	20
6.4 Dedicated Charging Port (DCP)	21
6.5 Port Numbers of Charging Downstream Port Configuration.....	21
CHAPTER 7 ELECTRICAL CHARACTERISTICS	22
7.1 Maximum Ratings	22
7.2 Operating Ranges	22
7.3 DC Characteristics	23
7.3.1 DC Characteristics except USB Signals.....	23
7.3.2 USB 2.0 Interface DC Characteristics	23
7.3.3 USB 3.0 Interface DC Characteristics	23
7.4 Power Consumption	23
7.5 On-Chip Power Regulator	25
CHAPTER 8 PACKAGE DIMENSION.....	26
CHAPTER 9 ORDERING INFORMATION.....	27

List of Figures

Figure 3.1 - GL3520M QFN 64 Pin Pinout Diagram	9
Figure 4.1 - Block Diagram	12
Figure 5.1 - Operating in USB 1.1 Schemes.....	15
Figure 5.2 - Operating in USB 2.0 Schemes.....	16
Figure 5.3 - Power on Reset Diagram.....	17
Figure 5.4 - Power on Sequence of GL3520M	17
Figure 5.5 - SELF/BUS Power Setting	18
Figure 5.6 - LED Connection	18
Figure 7.1 - Vin(V5) vs Vout(V33)*.....	25
Figure 8.1 - GL3520M 64 Pin QFN Package	26

List of Tables

Table 5.1 - Configuration by Power Switch Type	18
Table 7.1 - Maximum Ratings.....	22
Table 7.2 - Operating Ranges.....	22
Table 7.3 - DC Characteristics except USB Signals	23
Table 9.1 - Ordering Information.....	27



CHAPTER 1 GENERAL DESCRIPTION

GL3520M is a highly-compatible, high performance USB 3.0 hub controller, which integrates Genesys Logic own self-developed USB 3.0 Super Speed transmitter/receiver physical layer (PHY) and USB 2.0 High-Speed PHY. It supports Super Speed, Hi-Speed, and Full-Speed USB connections and is fully backward compatible to all USB 2.0 and USB 1.1 hosts. GL3520M is a premium 3 port MTT Hub solution, implementing multiple TT* (*Note1*) architecture that provide dedicated TT* to each downstream (DS) ports, which guarantee Full-Speed(FS) data passing bandwidth when multiple FS device perform heavy loading operations.

GL3520M also complies with USB-IF battery charging specification rev1.2, which can support fast charging function, allowing portable devices to draw up to 1.5A from GL3520M charging downstream ports (CDP¹) or dedicated charging port (DCP²). So it can enable systems to fast charge handheld devices even during “Sleep” and “Power-off” modes.

*Note: TT (transaction translator) implements the control logic defined in section 11.14 ~ 11.22 of USB specification revision 2.0. TT basically handles the unbalanced traffic speed between the USPORT (operating in HS) and DSPORTS (operating in FS/LS) of hub.

¹ CDP, charging downstream port, the Battery Charging Rev.1.2-compliant USB port that does data communication and charges device up to 1.5A.

² DCP, dedicated charging port, the Battery Charging Rev.1.2-compliant USB port that only charges devices up to 1.5A, similar to wall chargers.

CHAPTER 2 FEATURES

- Compliant with USB Specification Revision 3.0
 - Upstream port supports super speed(SS) high speed(HS) and full speed(FS) traffic
 - 3 downstream ports support SS, HS, FS, and low speed(LS) traffic
 - 1 control pipe and 1 interrupt pipe
 - Backward compatible to USB specification Revision 2.0/1.1
- Compliant with USB Battery Charging Revision v1.2
 - Turning its downstream port from a standard downstream port (SDP) into charging downstream port (CDP) or Dedicated Charging Ports (DCP).
 - Enables portable device to charge from VBUS even when the USB bus is in suspend.
- On-chip 8-bit micro-processor
 - RISC-like architecture
 - USB optimized instruction set
 - 1 cycle instruction execution(maximum)
 - Performance: 12 MIPS @ 12MHz(maximum)
 - With 256-byte RAM, 16K-byte internal ROM & 16K-byte SRAM
- Multi Transaction Translator(TT) architecture
 - Provides dedicated TT control logics for each downstream port
 - Superior performance when multiple FS devices operate concurrently
- Integrated USB transceiver
 - Improve output drivers with slew-rate control for EMI reduction
 - Internal power-fail detection for ESD recovery
- Smart power management
 - Support USB3.0 U0/U1/U2/U3 power management states
 - Support individual mode over-current detection
 - Support both low/high-enabled power switches.
 - Automatic switching between self-powered and bus-powered modes.
- Low BOM cost
 - Single external 25 MHz crystal / Oscillator clock input
 - Built-in 5V to 3.3V regulator
 - Built-in upstream port 1.5K Ω pull-up and downstream port 15K Ω pull-down resistors
- Flexible design
 - Support full in-system programming firmware upgrade by SPI-flash
- Available package type
 - QFN 64 (8x8mm)
- Applications:
 - Stand-alone USB hub / USB docking
 - Netbook/Smartbook/MID/Motherboard on-board applications
 - Monitor built-in hub
 - TV built-in hub
 - Other Consumer electronics built-in hub application
 - Compound device to support USB hub function such as hub reader applications

CHAPTER 3 PIN ASSIGNMENT

3.1 Pinout

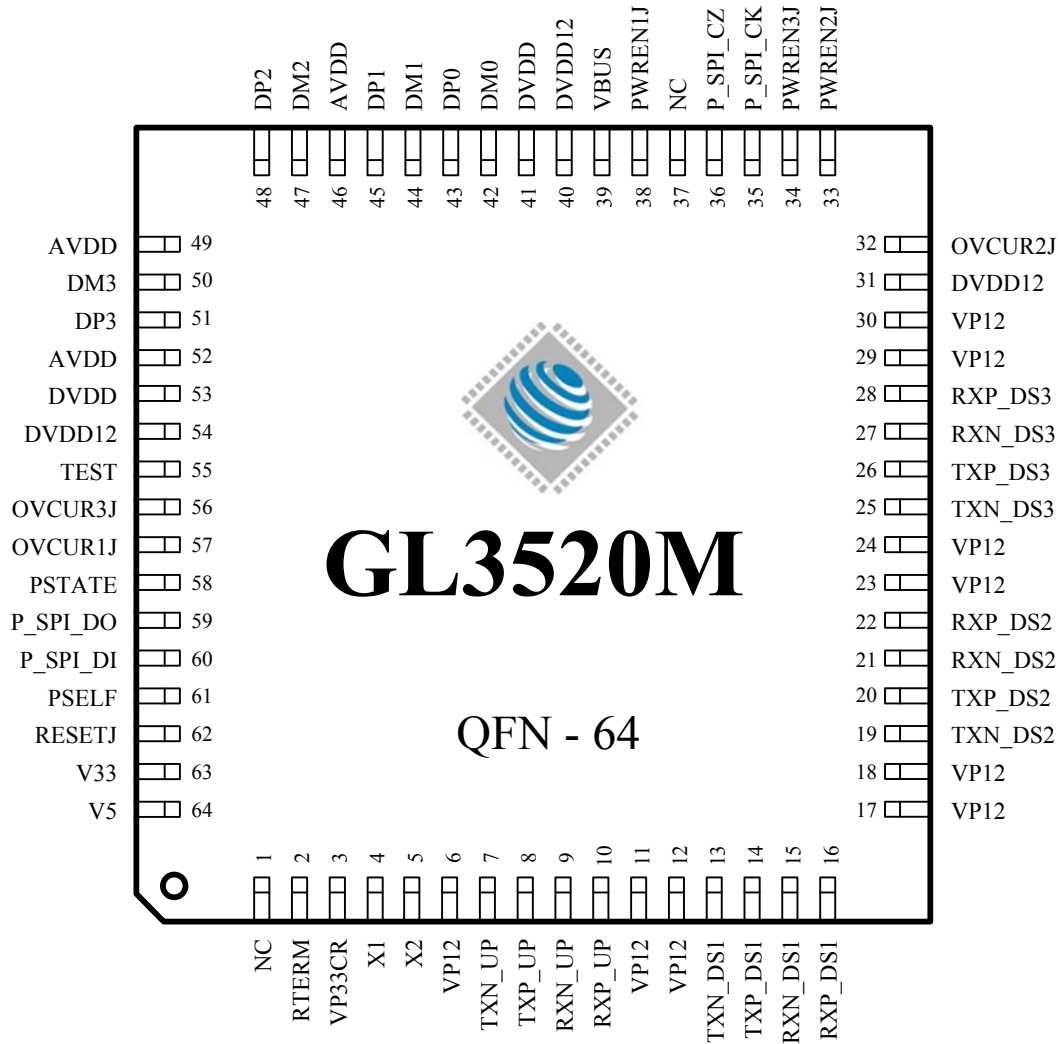

Figure 3.1 - GL3520M QFN 64 Pin Pinout Diagram

3.2 Pin Descriptions

USB Interface			
Pin Name	64 Pin#	Type	Description
TXN_UP TXP_UP	7, 8	O	USB 3.0 Differential Data Transmitter TX-/TX+ of USPORT
RXN_UP RXP_UP	9, 10	I	USB 3.0 Differential Data Receiver RX-/RX+ of USPORT
TXN_DS1 TXP_DS1	13, 14	O	USB 3.0 Differential Data Transmitter TX-/TX+ of DSPORT1
RXN_DS1 RXP_DS1	15, 16	I	USB 3.0 Differential Data Receiver RX-/RX+ of DSPORT1
TXN_DS2 TXP_DS2	19, 20	O	USB 3.0 Differential Data Transmitter TX-/TX+ of DSPORT2
RXN_DS2 RXP_DS2	21, 22	I	USB 3.0 Differential Data Receiver RX-/RX+ of DSPORT2
TXN_DS3 TXP_DS3	25, 26	O	USB 3.0 Differential Data Transmitter TX-/TX+ of DSPORT3
RXN_DS3 RXP_DS3	27, 28	I	USB 3.0 Differential Data Receiver RX-/RX+ of DSPORT3
DM0,DP0	42,43	B	USB 2.0 DM/DP for USPORT
DM1, DP1	44,45	B	USB 2.0 DM/DP for DSPORT1
DM2, DP2	47,48	B	USB 2.0 DM/DP for DSPORT2
DM3, DP3	50,51	B	USB 2.0 DM/DP for DSPORT3

Hub Interface			
Pin Name	64 Pin#	Type	Description
PSTATE	58	B (pd)	Output high for normal mode. When GL3520M is suspended, this pin will output low.
PWREN1J~3J	38,33,34	B	Active low. Power enable output for DSPORT1~3.
OVCUR1J~3J	57,32,56	I (pu)	Active low. Over current indicator for DSPORT1~3.
PSELF	61	I	0: GL3520M is bus-powered. 1: GL3520M is self-powered.

Clock and Reset Interface			
Pin Name	64 Pin#	Type	Description
X1	4	I	Crystal / OSC clock input
X2	5	O	Crystal clock output.
RESETJ	62	I	Active low. External reset input, default pull high 10KΩ. When RESETJ = low, whole chip is reset to the initial state.

SPI Interface			
Pin Name	64 Pin#	Type	Description
P_SPI_CK	35	B	For SPI data clock
P_SPI_CZ	36	B	For SPI data chip enable
P_SPI_DO	59	B	For SPI data Input
P_SPI_DI	60	B	For SPI data Output

Power/Ground Interface			
Pin Name	64 Pin#	Type	Description
VP33CR	3	P	Analog 3.3V power input
VP12	6,11,12,17,18, 23,24,29,30	P	Analog 1.2V power input for Analog circuit
DVDD12	31,40,54	P	1.2V digital power input for digital circuits
DVDD	41,53	P	3.3V digital power input for digital circuits
AVDD	46,49,52	P	Analog 3.3V power input
V5	64	P	5V Power input. It need be NC if using external regulator
V33	63	P	5V-to-3.3V regulator Vout (QFN64) It should connect to 3.3V power if using external regulator
VBUS	39	I	VBUS valid input

Miscellaneous Interface			
Pin Name	64 Pin#	Type	Description
RTERM	2	A	A 680ohm resister must be connected between RTERM and Ground
TEST	55	B (pd)	TEST: 0: Normal operation. 1: Chip will be put in test mode.
NC	1,37		Not connect

Note: Analog circuits are quite sensitive to power and ground noise. PCB layout must take care the power routing and the ground plane. For detailed information, please refer to **USB 3.0 Hub Design Guide**.

Notation:

Type	O	Output
	I	Input
	B	Bi-directional
	P	Power / Ground
	A	Analog
	pu	Internal pull up
	pd	Internal pull down

CHAPTER 4 BLOCK DIAGRAM

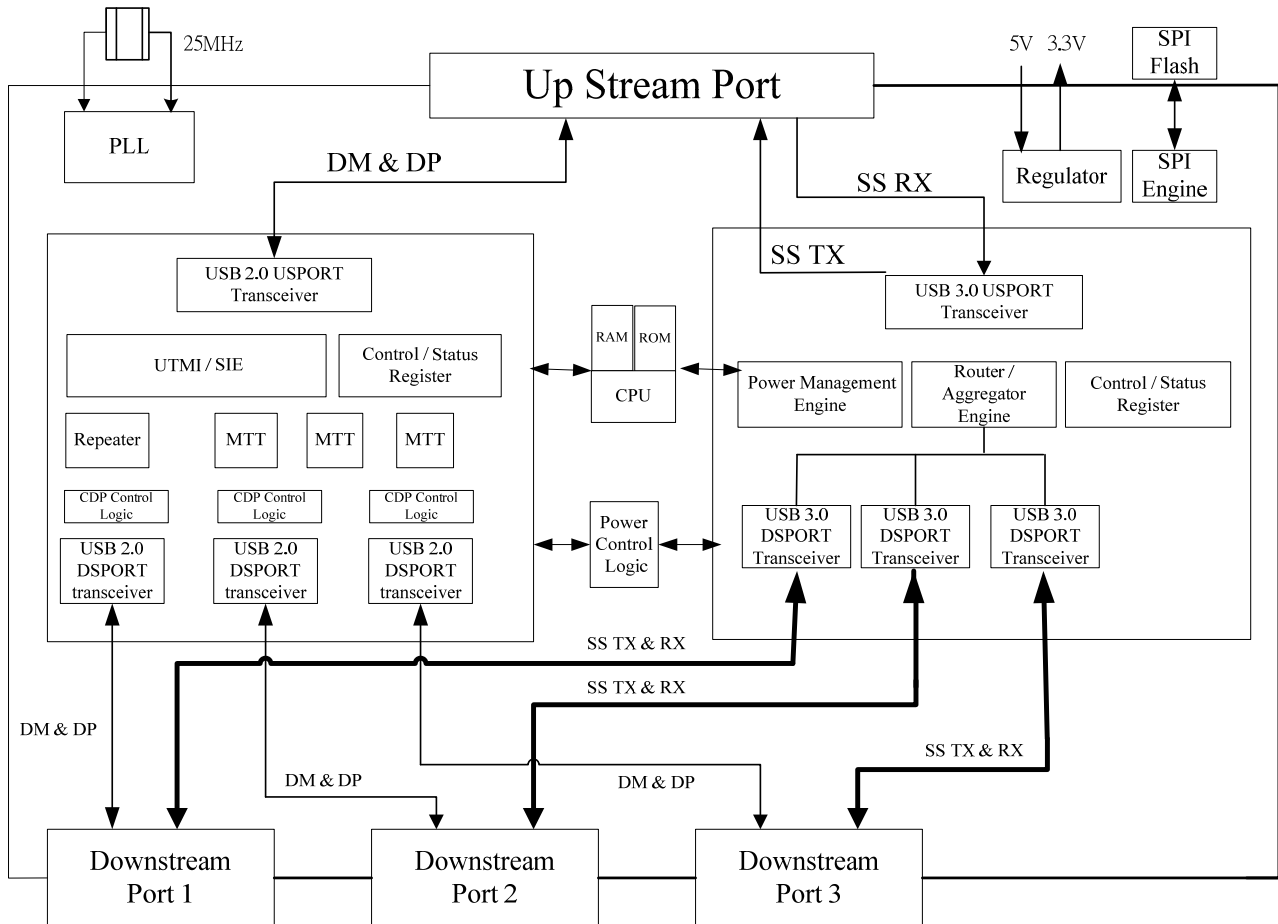

Figure 4.1 - Block Diagram

CHAPTER 5 FUNCTION DESCRIPTION

5.1 General Description

5.1.1 USB 2.0 USPORT Transceiver

USB 2.0 USPORT (upstream port) transceiver is the analog circuit that supports both full-speed and high-speed electrical characteristics defined in chapter 7 of USB specification revision 2.0. USPORT transceiver will operate in full-speed electrical signaling when GL3520M is plugged into a 1.1 host/hub. USPORT transceiver will operate in high-speed electrical signaling when GL3520M is plugged into a 2.0 host/hub.

5.1.2 USB 3.0 USPORT Transceiver

USB 3.0 USPORT (upstream port) transceiver is the analog circuit that has elastic buffer and supports receiver detection, data serialization and de-serialization. Besides, it has PIPE interface with SuperSpeed Link Layer

5.1.3 PLL (Phase Lock Loop)

PLL generates the clock sources for the whole chip. The generated clocks are proven quite accurate that help in generating high speed signal without jitter.

5.1.4 Regulator

GL3520M build in internal regulator converts 5V input to 3.3V output.

5.1.5 SPI Engine

SPI engine is to move code from external flash to the internal RAM.

5.1.6 RAM/ROM/CPU

The micro-processor unit of GL3520M is an 8-bit RISC processor with 16K-byte ROM and 256-bytes RAM. It operates at 12MIPS of 12 MHz clock(maximum) to decode the USB command issued from host and then prepares the data to respond to the host.

5.1.7 UTMI (USB 2.0 Transceiver Microcell Interface)

UTMI handles the low level USB protocol and signaling. It's designed based on the Intel's UTMI specification 1.01. The major functions of UTMI logic are to handle the data and clock recovery, NRZI encoding/decoding, Bit stuffing /de-stuffing, supporting USB 2.0 test modes, and serial/parallel conversion.

5.1.8 SIE (Serial Interface Engine)

SIE handles the USB protocol defined in chapter 8 of USB specification revision 2.0. It co-works with μC to play the role of the hub kernel. The main functions of SIE include the state machine of USB protocol flow, CRC check, PID error check, and timeout check. Unlike USB 1.1, bit stuffing/de-stuffing is implemented in UTMI, not in SIE.

5.1.9 Control/Status Register

Control/Status register is the interface register between hardware and firmware. This register contains the information necessary to control endpoint0 and endpoint1 pipelines. Through the firmware based architecture, GL3520M possesses higher flexibility to control the USB protocol easily and correctly.

5.1.10 Power Management Engine

The power management of GL3520M is compliant with USB 3.0 specification. When operates in

SuperSpeed mode, GL3520M supports U0, U1, U2 and U3 power states. U0 is the functional state. U1 and U2 are lower power states compared to U0. U1 is a low power state with fast exit to U0; U2 is a low power state which saves more power than U1, with slower exit to U0. U3 is suspend state, which is the most power-saving state, with tens of milliseconds exit to U0. Unlike USB 2.0, SuperSpeed packet traffic is unicast rather than broadcast. Packet only travels the direct path in-between host and the target device. SuperSpeed traffic will not reach an unrelated device. When enabled for U1/U2 entry, and there is no pending traffic within comparable exit latency, GL3520M will initiate U1/U2 entry to save the power. On the other hand, the link partner of GL3520M may also initiate U1/U2 entry. In this case, GL3520M will accept or reject low power state entry according to its internal condition.

5.1.11 Router/Aggregator Engine

Router/Aggregator Engine implement the control logic defined in Ch10 of USB3.0 specification. Router/Aggregator Engine use smart method for route packet to device or aggregate packet to host.

5.1.12 REPEATER

Repeater logic implements the control logic defined in section 11.4 and section 11.7 of USB specification revision 2.0. REPEATER controls the traffic flow when upstream port and downstream port are signaling in the same speed. In addition, REPEATER will generate internal resume signal whenever a wakeup event is issued under the situation that hub is globally suspended.

5.1.13 TT

TT(Transaction Translator) implements the control logic defined in section 11.14 ~ 11.22 of USB specification revision 2.0. TT basically handles the unbalanced traffic speed between the USPORT (operating in HS) and DSPORTS (operating in FS/LS) of hub. GL3520M adopts multiple TT architecture to provide the most performance effective solution. Multiple TT provides control logics for each downstream port respectively.

5.1.13.1 Connected to 1.1 Host/Hub

If an USB 2.0 hub is connected to the downstream port of an USB 1.1 host/hub, it will operate in USB 1.1 mode. For an USB 1.1 hub, both upstream direction traffic and downstream direction traffic are passing through REPEATER. That is, the REPEATER/TT routing logic will route the traffic channel to the REPEATER.

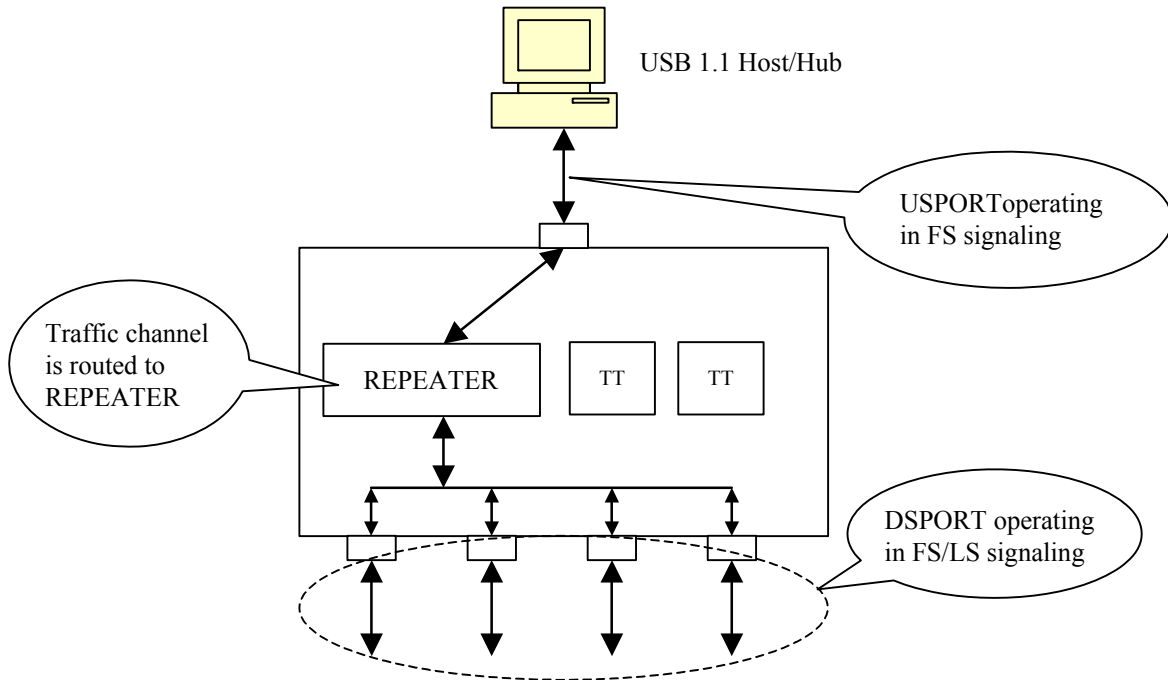

Figure 5.1 - Operating in USB 1.1 Schemes

5.1.13.2 Connected to USB 2.0 Host/Hub

If an USB 2.0 hub is connected to an USB 2.0 host/hub, it will operate in USB 2.0 mode. The upstream port signaling is in high speed with bandwidth of 480 Mbps under this environment. The traffic channel will then be routed to the REPEATER when the device connected to the downstream port is signaling also in high speed. On the other hand, the traffic channel will then be routed to TT when the device connected to the downstream port is signaling in full/low speed.

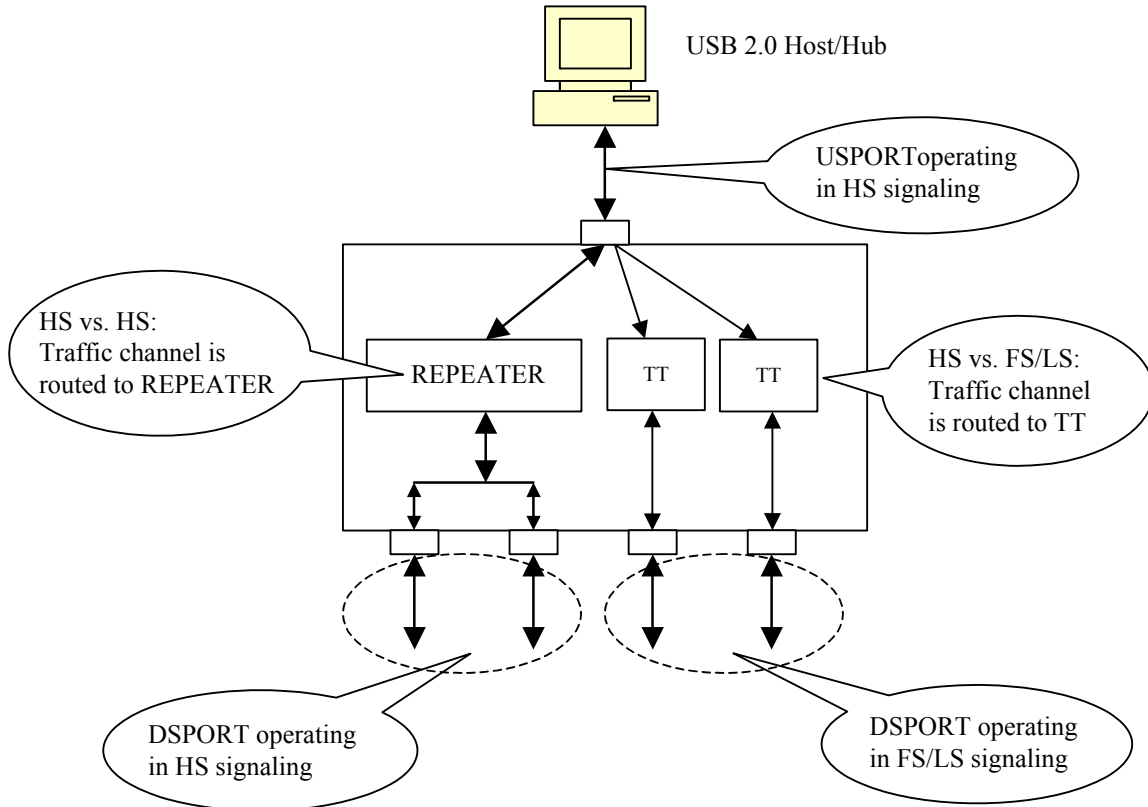

Figure 5.2 - Operating in USB 2.0 Schemes

5.1.14 CDP Control Logic

CDP (charging downstream port) control logic implements the logic defined in USB Battery charging specification revision 1.2. The major function of it is to control DSPORT Transceiver to make handshake with a portable device which is compliant with USB Battery charging spec rev1.2 as well. After recognizing charging detection each other, portable device will draw up to 1.5A from VBUS to fast charge its battery.

5.1.15 USB 3.0/USB 2.0 DSPORT Transceiver

DSPORT transceiver is the analog circuit that supports high-speed, full-speed, and low-speed electrical characteristics. In addition, each DSPORT transceiver accurately controls its own squelch level to detect the detachment and attachment of devices.

5.2 Configuration and I/O Settings

5.2.1 RESET Setting

GL3520M's power on reset can either be triggered by external reset or internal power good reset circuit. The external reset pin, RESETJ, is connected to upstream port Vbus (5V) to sense the USB plug / unplug or 5V voltage drop. The reset trigger voltage can be set by adjusting the value of resistor R1 and R2 (Suggested value refers to schematics) GL3520M's internal reset is designed to monitor silicon's internal core power (1.2V) and initiate reset when unstable power event occurs. The power on sequence will start after the power good voltage has been met, and the reset will be released after approximately 40 μ S after power good. GL3520M's reset circuit as depicted in the picture.

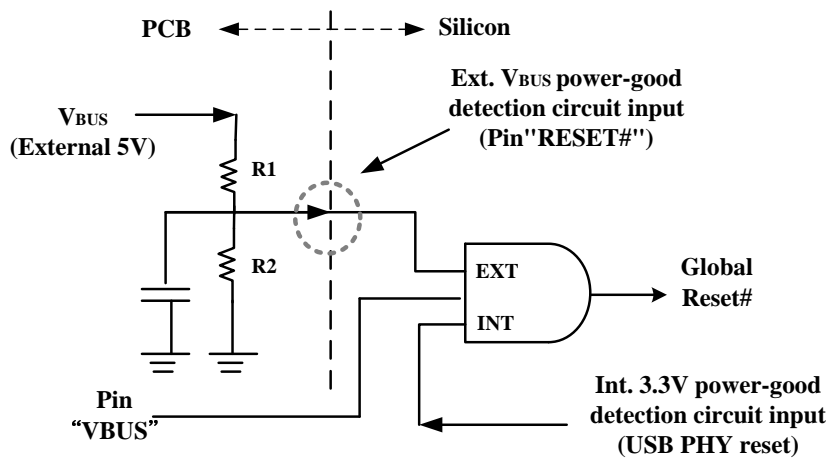

Figure 5.3 - Power on Reset Diagram

To fully control the reset process of GL3520M, we suggest the reset time applied in the external reset circuit should longer than that of the internal reset circuit. Timing of POR is illustrated as below figure.

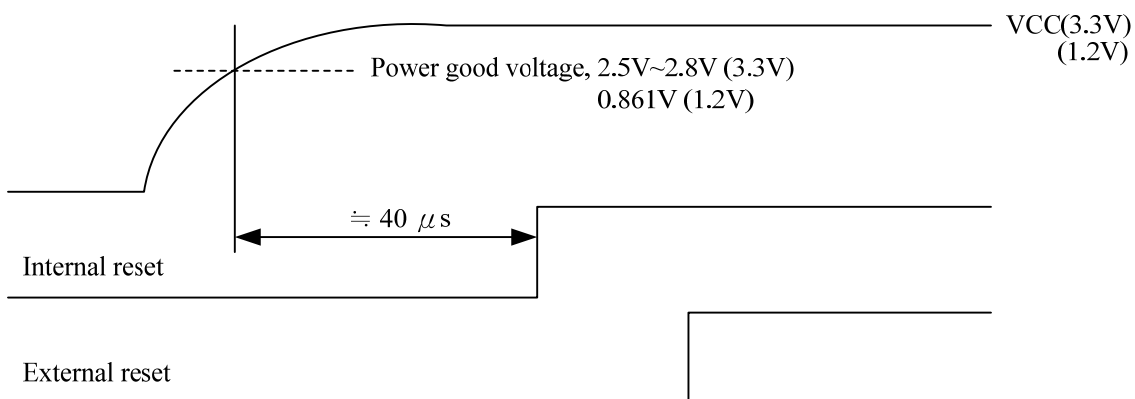

Figure 5.4 - Power on Sequence of GL3520M

5.2.2 SELF/BUS Power Setting

By setting PSELF, GL3520M can be configured as a bus-power or a self-power hub.

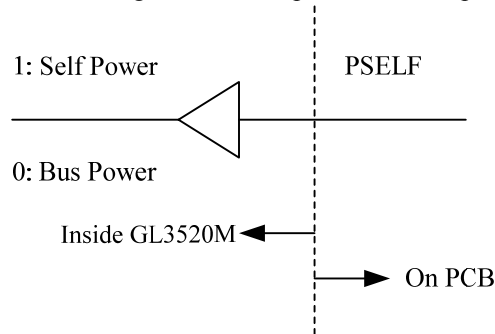

Figure 5.5 - SELF/BUS Power Setting

5.2.3 LED Connections

GL3520M controls the LED lighting according to the flow defined in section 11.5.3 of Universal Serial Bus Specification Revision2.0. Both manual mode and Automatic mode are supported in GL3520M. When GL3520M is globally suspended, GL3520M will turn off the LED to save power.

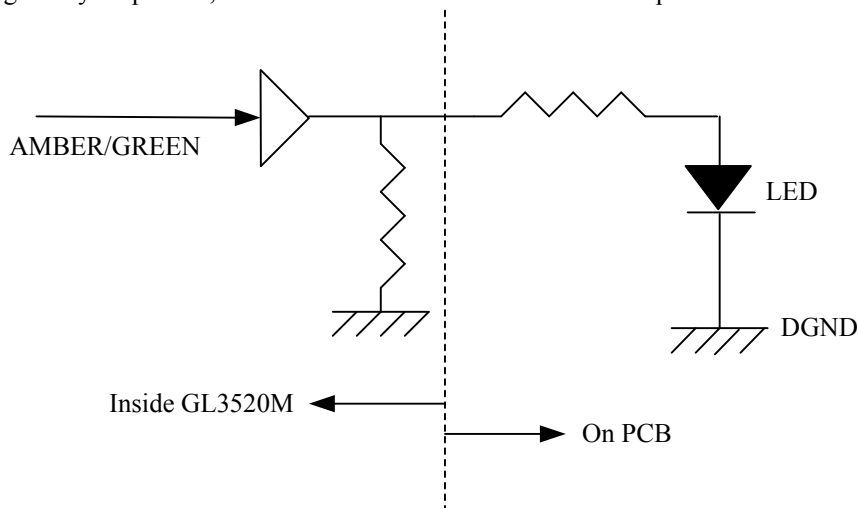

Figure 5.6 - LED Connection

5.2.4 Power Switch Enable Polarity

Both low/high-enabled power switches are supported. It is determined by jumper setting. The power switch polarity will be configured by the state of pin AMBER2, as the following table:

Table 5.1 - Configuration by Power Switch Type

AMBER2	Power Switch Enable Polarity
0	Low-active
1	High-active

Note: When AMBER2=1, the external resistor of PWREN1~4 need pull down

5.2.5 Port Number Configuration

Number of downstream port can be configured as 1/2/3 ports by firmware configuration. The detail setting information please refers to the **Genesys USB 3.0 Hub FW ISP Tool User Guide** document.

5.2.6 Non-removable Port Configuration

For compound application or embedded system, downstream ports that always connected inside the system can be set as non-removable by firmware configuration. The detail setting information please refers to the **Genesys USB 3.0 Hub FW ISP Tool User Guide** document.

CHAPTER 6 USB-IF BATTERY CHARGING SPECIFICATION REV.1.2 SUPPORT

6.1 Background

The USB ports on personal computers are convenient places for portable devices to draw current for charging their batteries. This convenience has led to the creation of dedicated chargers that simply expose a USB standard-A receptacle. This allows portable devices to use the same USB cable to charge from either a PC or from a dedicated charger.

If a portable device is attached to a USB host or hub, then the USB 2.0 specification requires that after connecting, a portable device must draw less than:

- 2.5 mA average if the bus is suspended
- 100 mA maximum if bus is not suspended and not configured
- 500 mA maximum if bus is not suspended and configured for 500 mA
-

If a portable device is attached to a charging host or hub, it is allowed to draw a current up to 1.5A or 900mA, regardless of suspend. In order for a portable device determine how much current it is allowed to draw from an upstream USB port, the USB-IF Battery Charging specification defines the mechanisms that allow the portable device to distinguish between either a USB standard host, hub or a USB charging host. Since portable device can be attached to USB charging ports from various manufactures, it is important that all USB charging ports behave the same way. This specification also defines the requirements for a USB chargers and charging downstream ports.

6.2 Charging Downstream Port (CDP)

GL3520M supports battery charging detection, turning its downstream port from a standard downstream port (SDP) into charging downstream port (CDP). GL3520M will make physical layer handshaking when a portable device (PD) compliant with BC rev1.2 attaches to its downstream port. After physical layer handshaking, PD is allowed to draw more current up to 900mA or 1.5A, depending on PD is configured as High-Speed (900mA) or Full-Speed/Low-Speed (1.5A) device.

6.3 Charging Detection Hardware Handshaking

Once the charging downstream port of GL3520M enabled, it will monitor the V_{DP_SRC} on D+ line anytime. When BCv1.2 compliant PD attached to the downstream port, it will drive V_{DP_SRC} on D+ line to initiate handshaking with charging downstream port. GL3520M will response on its D- line by V_{DM_SRC} and keep in a certain period of time and voltage level. The portable device will accept this handshake on its D- line in correct timing period and voltage level and then turns off its V_{DP_SRC} on D+ line. GL3520M will recognize that charging negotiation is finished by counting time between PD turning on and off its V_{DP_SRC} . After that, the portable device can start to draw more current at VBUS to charge its battery more rapidly. It can draw current up to 1.5A or 900mA, depending on PD is configured as HS, FS or LS device.

If no response on D- line returns, the portable device will recognize that it is attached to a standard downstream port, not a charging port.

6.4 Dedicated Charging Port (DCP)

GL3520M also support dedicated charging port, which is a downstream port on a device that outputs power through a USB connector, but is not capable of enumerating a downstream device. With the adequate system circuit design, GL3520M will turn its downstream port from a standard downstream port (SDP) into dedicated charging port (DCP), i.e short the D+ line to the D- line, to let PD draw current up to 1.5A. The detail system design information please refers to the **USB 3.0 Hub Design Guide** document.

6.5 Port Numbers of Charging Downstream Port Configuration

Numbers of charging downstream port can be configured as 1/2/3 ports by firmware configuration. The detail setting information please refers to the **Genesys USB 3.0 Hub FW ISP Tool User Guide** document.

CHAPTER 7 ELECTRICAL CHARACTERISTICS

7.1 Maximum Ratings

Table 7.1 - Maximum Ratings

Symbol	Parameter	Min.	Max.	Unit
V ₅	5V Power Supply	-0.5	+6.0	V
V _{DD}	3.3V Power Supply	-0.5	+3.6	V
VDDcore	1.2V Power Supply	-0.5	+1.32	V
V _{IN}	3.3V Input Voltage for digital I/O(EE_DO) pins	-0.5	+3.6	V
V _{incore}	1.2V	-0.5	+1.32	V
V _{INOD}	Open-Drain Input (Ovcur1-4,Pself,Reset)	-0.5	+5.5	V
V _{INUSB}	Input Voltage for USB signal (DP, DM) pins	-0.5	+3.6	V
T _S	Storage Temperature under bias	-60	+100	°C
F _{OSC}	Frequency	25 MHz ± 0.03%		

7.2 Operating Ranges

Table 7.2 - Operating Ranges

Symbol	Parameter	Min.	Typ.	Max.	Unit
V ₅	5V Power Supply	4.75	5.0	5.25	V
V _{DD}	3.3V Power Supply	3.0	3.3	3.6	V
VDDcore	1.2V Power Supply	1.08	1.2	1.32	V
V _{IND}	Input Voltage for digital I/O pins	-0.5	3.3	3.6	V
V _{INUSB}	Input Voltage for USB signal (DP, DM) pins	0.5	3.3	3.6	V
T _A	Ambient Temperature	0	-	70	°C
T _J	Absolute maximum junction temperature	0	-	125	°C

7.3 DC Characteristics

7.3.1 DC Characteristics except USB Signals

Table 7.3 - DC Characteristics except USB Signals

Symbol	Parameter	Min.	Typ.	Max.	Unit
V _{DD}	Power Supply Voltage	3	3.3	3.6	V
V _{IL}	LOW level input voltage	-	-	0.8	V
V _{IH}	HIGH level input voltage	2.0	-	-	V
V _{TLH}	LOW to HIGH threshold voltage	1.4	1.5	1.6	V
V _{THL}	HIGH to LOW threshold voltage	0.87	0.94	0.99	V
V _{OL}	LOW level output voltage when I _{OL} =8mA	-	-	0.4	V
V _{OH}	HIGH level output voltage when I _{OH} =8mA	2.4	-	-	V
I _{OLK}	Leakage current for pads with internal pull up or pull down resistor	-	-	30	μA
R _{DN}	Pad internal pull down resister	31K	50K	92K	Ω
R _{UP}	Pad internal pull up resister	36K	50K	76K	Ω
	Pad internal pull up (for OVCUR1~4J) resister	303K	443K	714K	Ω

7.3.2 USB 2.0 Interface DC Characteristics

The GL3520M conforms to DC characteristics for Universal Serial Bus specification rev. 2.0. Please refer to this specification for more information.

7.3.3 USB 3.0 Interface DC Characteristics

The GL3520M conforms to DC characteristics for Universal Serial Bus specification rev.3.0. Please refer to this specification for more information.

7.4 Power Consumption

Symbol	USB 3.0 Host Number of USB 3.0 Active Ports	Config.	Read	Write	Unit
I _{CC}	3	0.18	0.78	0.80	W
	2	0.18	0.66	0.66	W
	1	0.17	0.51	0.50	W
	USPORT Config		0.01		W

Symbol	USB 3.0 Host Number of USB 2.0 Active Ports	Config.	Read	Write	Unit
I _{CC}	3	0.25	0.31	0.30	W
	2	0.22	0.25	0.26	W
	1	0.18	0.19	0.20	W
	USPORT Config	0.01			W

Note:

Test result represents silicon level operating current, without considering additional power consumption contributed by external over-current protection circuit such as power switch or polyfuse.

7.5 On-Chip Power Regulator

GL3520M requires 3.3V source power for normal operation of internal core logic and USB physical layer (PHY). The integrated low-drop power regulator converts 5V power input from USB cable (Vbus) to 3.3V voltage for silicon power source. The 3.3V power output is guaranteed by an internal voltage reference circuit to prevent unstable 5V power compromise USB data integrity. The regulator's maximum current loading is 250mA, which provides enough tolerance for normal GL3520M operation (below 100mA).

On-chip Power Regulator Features:

- 5V to 3.3V low-drop power regulator
- 250mA maximum output driving capability
- Provide stable 3.3V output when $V_{in} = 3.4V \sim 5.5V$
- 125uA maximum quiescent current (typical 80uA).

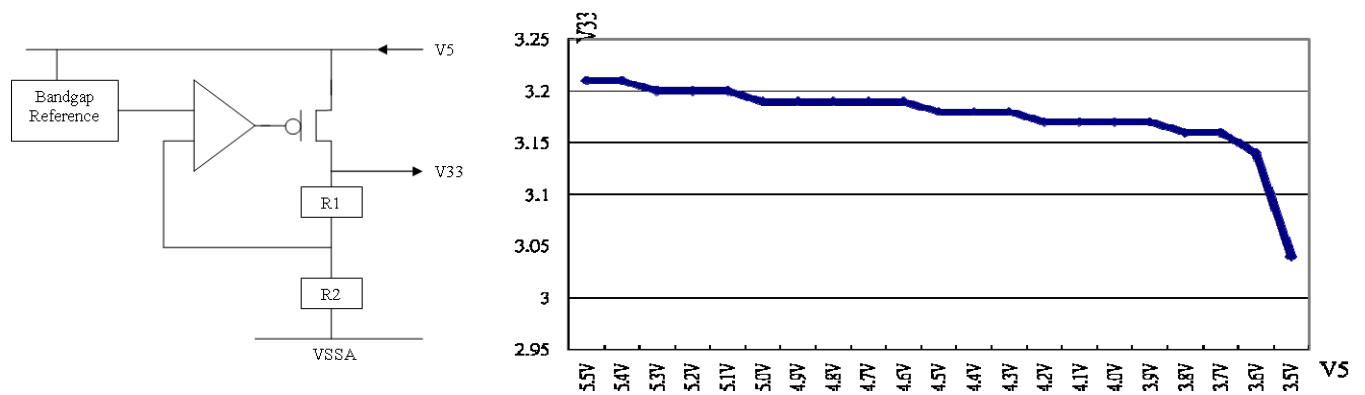

Figure 7.1 - $V_{in}(V5)$ vs $V_{out}(V33)^*$

*Note: Measured environment: Ambient temperature = 25°C / Current Loading = 250mA

CHAPTER 8 PACKAGE DIMENSION

SYMBOL	DIMENSION MM (MIL)		
	MIN.	NOM.	MAX.
A	0.70 (27.6)	0.75 (29.5)	0.80 (31.5)
A1	---	0.02 (0.8)	0.05 (2.0)
A3	0.203 (8.0) REF		
b	0.15 (5.9)	0.20 (7.9)	0.25 (9.8)
D	8.00 (315.0) BSC		
D2	5.60 (220.5)	6.00 (236.2)	6.40 (252.0)
E	8.00 (315.0) BSC		
E2	5.60 (220.5)	6.00 (236.2)	6.40 (252.0)
e	0.40 (15.7) BSC		
L	0.30 (11.8)	0.40 (15.7)	0.50 (19.7)

NOTE: 1. REFER TO JEDEC STD. MO-220
2. ALL DIMENSIONS IN MILLIMETERS.

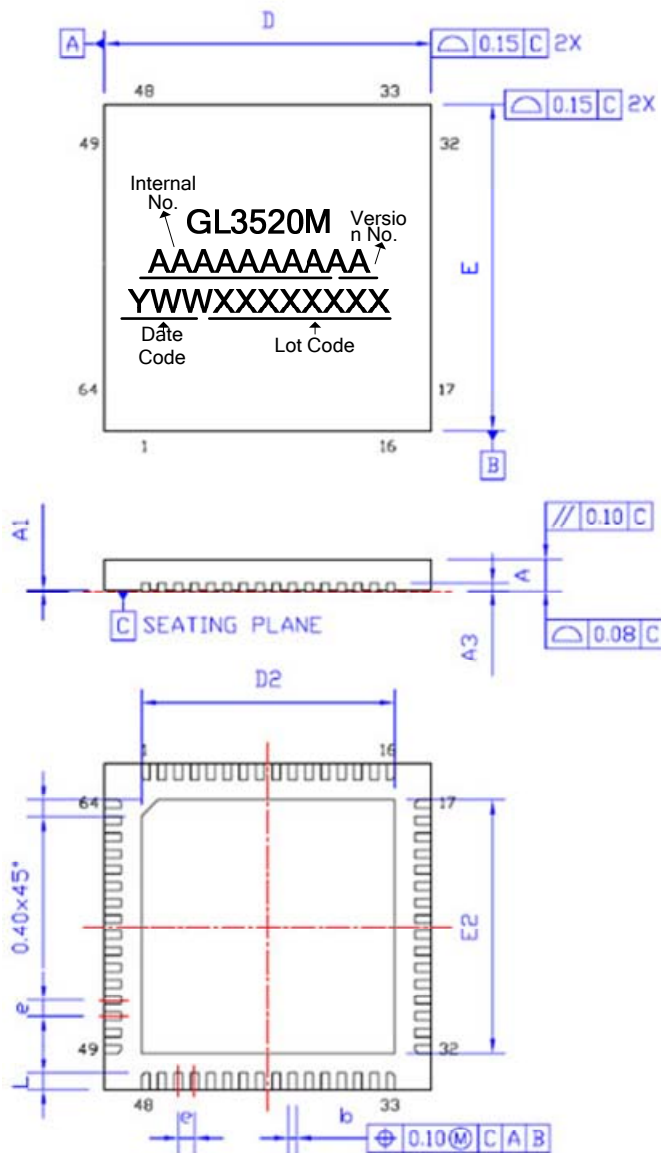

Figure 8.1 - GL3520M 64 Pin QFN Package

CHAPTER 9 ORDERING INFORMATION

Table 9.1 - Ordering Information

Part Number	Package	Material	Version	Status
GL3520M-OSYXX	QFN 64	Green Package	XX	Available