

GL358/358A

DUAL OPERATIONAL AMPLIFIER

Description

The GL358 consists of two independent, high gain, internally frequency compensated operational amplifiers which were specifically to operate from a single power supply over a wide range of voltage and the power supply current drain is independent of the magnitude of the power supply voltage

Application areas include transducer amplifiers, dc gain blocks and all the conventional OP AMP circuits which now can be more easily implemented in single power systems.

Pin Configuration

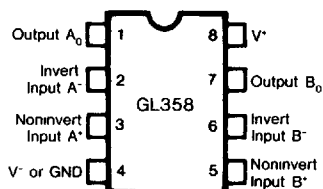

Features

- Input Common Mode Voltage Range Includes Ground.
- Wide Power Supply Range. (Single or Dual Supply) 3V to 30V or $\pm 1.5V$ to $\pm 16V$
- Large Output Voltage Swing. 0V to $V^+ - 1.5V$
- Internally Frequency Compensated for Unity Gain.
- Low Input Bias Current.
- Low Input Offset Voltage.
- Very Low Supply Current Drain.

Absolute Maximum Ratings

Supply Voltage, V^+	32 or ± 16	V
Differential Input Voltage	± 32	V
Input Voltage	-0.3 to 32	V
Power Dissipation	570	mW
Operating Temperature Range	0 to 70	$^{\circ}C$
Storage Temperature Range	-55 to 125	$^{\circ}C$
Lead Temperature	260	$^{\circ}C$

Schematic Diagram (Each Amplifier)

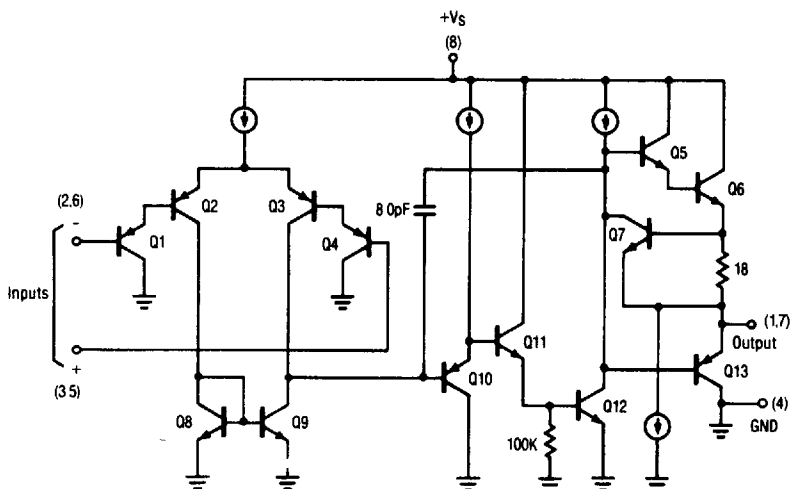

Electrical Characteristics:

Unless otherwise stated, these specification apply for $V^*=5V$, $V^*Max=30V$ and $0^\circ C \leq T_A \leq 70^\circ C$

PARAMETER	SYMBOL	TEST CONDITIONS	GL358			GL358A			UNIT	
			MIN	TYP	MAX	MIN	TYP	MAX		
Input Offset Voltage	V_{IO}	$V^*=5V$ to Max, $V_O=1.4V$, $R_S=0\Omega$ $V_{ICR}=0V$ to $V^*-1.5V$ $T_A=25^\circ C$		± 2	± 7 ± 9		± 2	± 3 ± 5	mV	
Input Offset Current	I_{IO}	$I_{IN(+)} - I_{IN(-)}$, $V_O=1.4V$ $T_A=25^\circ C$		± 5	± 50 ± 150		± 5	± 30 ± 75	nA	
Input Bias Current	I_{IB}	$I_{IN(+)}$ or $I_{IN(-)}$, $V_O=1.4V$ $T_A=25^\circ C$		45 40	250 500		45 40	100 200	nA	
Input Common-Mode Voltage range	V_{ICR}	$V^*=5V$ to Max $T_A=25^\circ C$	0 to $V^*-1.5V$ $V^*-2.0V$			0 to $V^*-1.5V$ $V^*-2.0V$			V	
Supply Current	I^+, I^-	$R_L = \infty$		0.7	1.2		0.7	1.2	mA	
		$V^*=5V$, $V_O=2.5V$ $V^*=Max$, $V_O=15V$		1	2		1	2		
Large-Signal Voltage Gain	A_{VD}	$V^*=15V$, $R_L \geq 2K\Omega$ $V_O=-5V$ to $+5V$ $T_A=25^\circ C$	25 15	100		25 15	100		V/mV	
Output Voltage Swing	V_{OH}	$V^*=MAX$	$R_L=2K\Omega$		26	$R_L=2K\Omega$		26	V	
	V_{OL}	$V^*=5V$, $R_L \leq 10K\Omega$	27	28		27	28			
Common Mode Rejection Ratio	CMRR	$T_A=25^\circ C$ $V^*=5V$ to Max	65	70		65	85		dB	
Power Supply Rejection Ratio	PSRR	$V^*=5V$ to Max $T_A=25^\circ C$	65	100		65	100		dB	
Output Current	Source	$V_{IN(+)}=1V$, $V_{IN(-)}=0V$ $T_A=25^\circ C$ $V^*=15V$, $V_O=4V$	20	40		20	40		mA	
	Sink	$V^*=15V$ $V_{IN(-)}=1V$ $V_{IN(+)}=0V$ $T_A=25^\circ C$	$V_O=15V$		10	20	$V_O=15V$		10	20
		$V_O=200mV$		12	50	$V_O=200mV$		12	50	μA
Short Circuit Current	I_{OS}	$V^*=5V$ $T_A=25^\circ C$ $V_O=0V$		40	60		40	60	mA	
Input Offset Voltage Drift	$\Delta V_{OS}/\Delta T$			7			7		$\mu V/^\circ C$	
Input Offset Current Drift	$\Delta I_{IO}/\Delta T$			10			10		$pA/^\circ C$	

TYPICAL PERFORMANCE CURVES

Figure 1 - Input Voltage Range

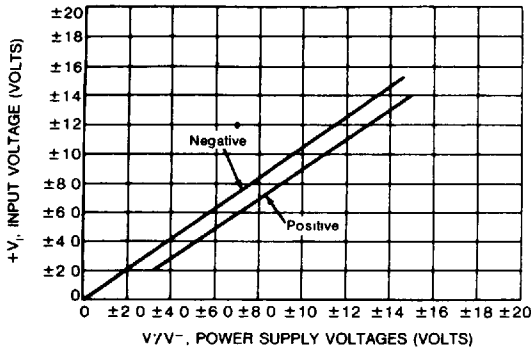

Figure 2 - Open Loop Frequency Response

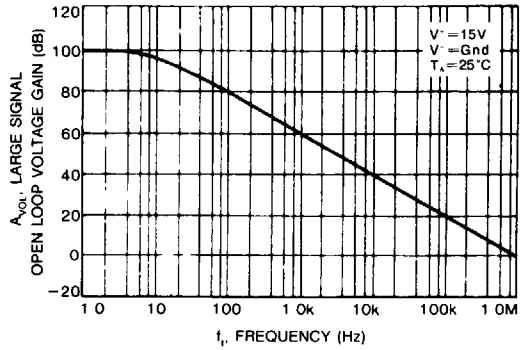

Figure 3 - Large Signal Frequency Response

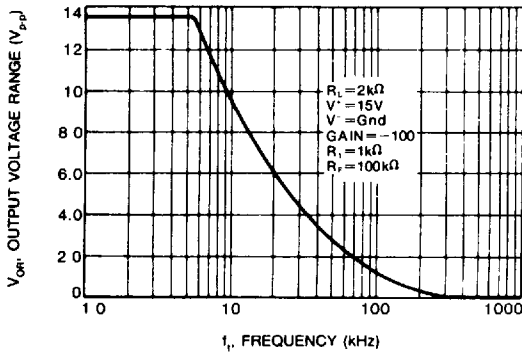

Figure 4 - Small Signal Follower Pulse Response (Non Inverting)

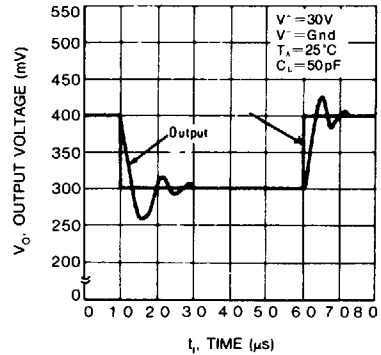

Figure 5 - Power Supply Current versus Power Supply Voltage

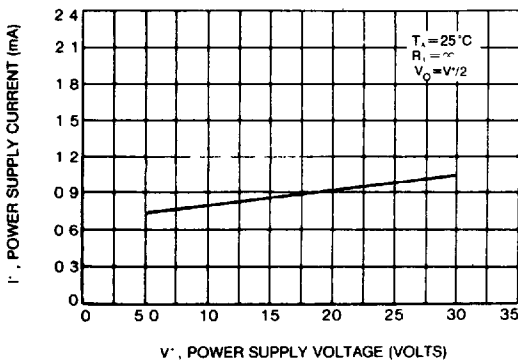
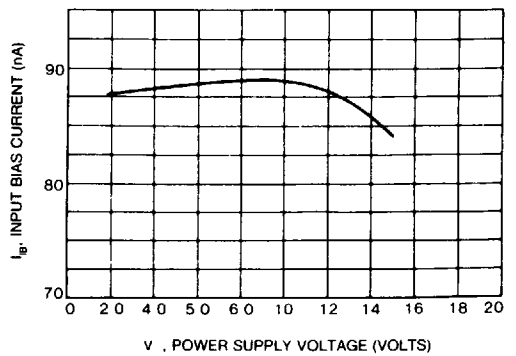

Figure 6 - Input Bias Current versus Supply Voltage



Typical Application

Figure 1 — Function Generator

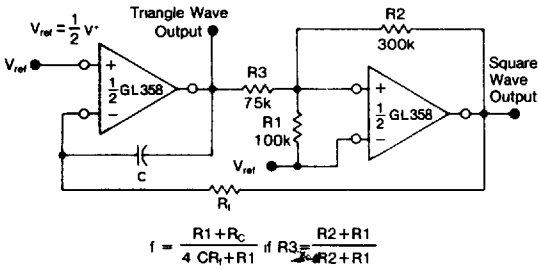

Figure 2 — Wien Bridge Oscillator

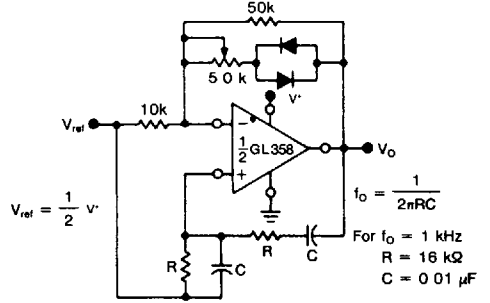

Figure 3 — High Impedance Differential Amplifier

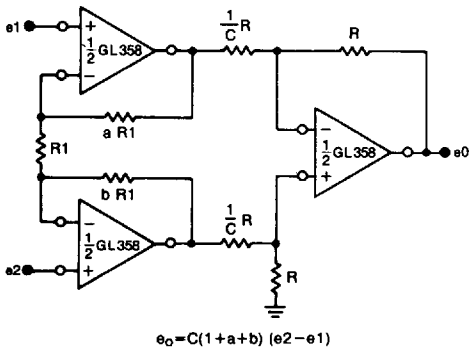

Figure 4 — Comparator With Hysteresis

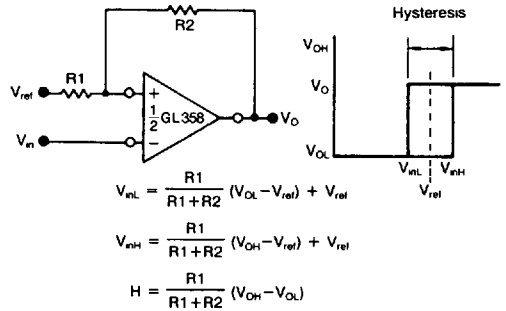

Figure 5 — Bi-Quad Filter

