



General Description

The GL6020 is a 2A CMOS LDO regulator that features a low quiescent current, ultra low input, output and dropout voltages, as well as over temperature shutdown. It is available in SOT-223 , and SOP-8(exposed pad) packages. The fixed output voltage of the GL6020 is set at the factory and trimmed to $\pm 2\%$. The GL6020 is stable with a ceramic output capacitor of 1.0uF or higher.

This family of regulators can provide either a stand-alone power supply solution or act as a post regulator for switch mode power supplies. They are particularly well suited for applications requiring low input and output voltages.

Key Features

- ◆ Low-Dropout Regulator Supports Input Voltages Down to 1.4V
- ◆ Output Voltage Available in 0.9V, 1.0V, 1.2V, 1.5V, 1.8V, 2.5V, 2.8V, 2.85V, 3.0V, 3.3V
- ◆ Stable with a Ceramic Output Capacitor of 1.0uF or Higher
- ◆ Low Dropout Voltage: 250mV @2A
- ◆ Low Quiescent Current
- ◆ Over Temperature Shutdown
- ◆ Short Circuit Protection
- ◆ Low Temperature Coefficient
- ◆ Standard SOT-223, and SOP-8 (Exposed Pad) Packages
- ◆ Pb-Free Package

Application

DSP, FPGA, and Microprocessor Power Supply
1.2V Core Voltage for DSPs
SATA Power Supply
LCD TV/ Monitors
Wireless Devices
Communication Devices
Portable Electronics
Post Regulator for SMPS

TYPICAL APPLICATION CIRCUITS

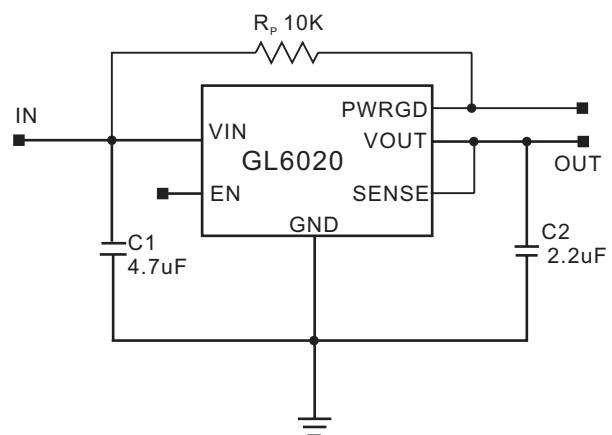
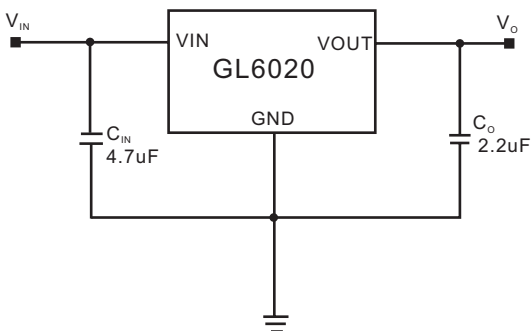

◆ MARKING INFORMATION & PIN CONFIGURATIONS (TOP VIEW)

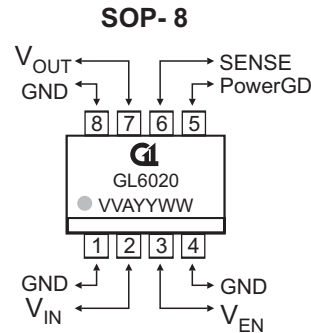
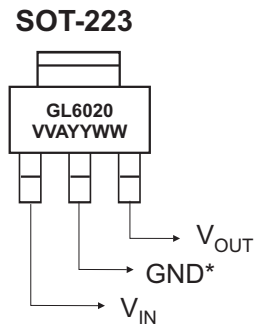

V V = Output Voltage (18=1.8V , 25=2.5V)
 A = Assembly Location
 YY = Year
 W W = Weekly

◆ ORDERING INFORMATION (Green Package Products are available now!)

ORDERING NUMBER	OUTPUT VOLTAGE	PACKAGE	SHIPPING
GL6020			
GL6020-0.9ST3R	0.9V	SOT-223	2,500 Units/ Tape & Reel
GL6020-0.9S8R	0.9V	SOP-8	2,500 Units/ Tape & Reel
GL6020-1.0ST3R	1.0V	SOT-223	2,500 Units/ Tape & Reel
GL6020-1.0S8R	1.0V	SOP-8	2,500 Units/ Tape & Reel
GL6020-1.2ST3R	1.2V	SOT-223	2,500 Units/ Tape & Reel
GL6020-1.2S8R	1.2V	SOP-8	2,500 Units/ Tape & Reel
GL6020-1.5ST3R	1.5V	SOT-223	2,500 Units/ Tape & Reel
GL6020-1.5S8R	1.5V	SOP-8	2,500 Units/ Tape & Reel
GL6020-1.8ST3R	1.8V	SOT-223	2,500 Units/ Tape & Reel
GL6020-1.8S8R	1.8V	SOP-8	2,500 Units/ Tape & Reel
GL6020-2.5ST3R	2.5V	SOT-223	2,500 Units/ Tape & Reel
GL6020-2.5S8R	2.5V	SOP-8	2,500 Units/ Tape & Reel
GL6020-2.8ST3R	2.8V	SOT-223	2,500 Units/ Tape & Reel
GL6020-2.8S8R	2.8V	SOP-8	2,500 Units/ Tape & Reel
GL6020-2.85ST3R	2.85V	SOT-223	2,500 Units/ Tape & Reel
GL6020-2.85S8R	2.85V	SOP-8	2,500 Units/ Tape & Reel
GL6020-3.0ST3R	3.0V	SOT-223	2,500 Units/ Tape & Reel
GL6020-3.0S8R	3.0V	SOP-8	2,500 Units/ Tape & Reel
GL6020-3.3ST3R	3.3V	SOT-223	2,500 Units/ Tape & Reel
GL6020-3.3S8R	3.3V	SOP-8	2,500 Units/ Tape & Reel

* For detail Ordering Number identification, please see last page.



Absolute Maximum Ratings

These are stress ratings only and functional operation is not implied. Exposure to absolute maximum ratings for prolonged time periods may affect device reliability. All voltages are with respect to ground.

Input Voltage.....4.0V	Maximum Output Current..... $P_D/(V_{IN}-V_O)$
Output Pin Voltage.....-0.3V to $V_{IN}+0.3V$	Storage Temperature..... -65°C to 150°C
Operation Temperature Range.....-40°C to 85°C	Maximum Junction Temperature.....150°C
Operation Junction Temperature.....-40°C to 125°C	Soldering Temperature.....300°C, 5sec

Recommended Operating Conditions

Supply Voltage Range.....1.4V to 3.6V	Junction Temperature Range..... -40°C to 125°C
Operation Temperature Range.....-40°C to 85°C	

Thermal Information

Parameter	Symbol	Package	Maximum	Unit
Thermal Resistance (Junction to Case)	θ_{JC}	SOT-223	7	°C/W
Thermal Resistance (Junction to Ambient)	θ_{JA}	SOT-223	160	
Internal Power Dissipation	P_D	SOT-223	625	mW

◆ **FUNCTIONAL DIAGRAM**

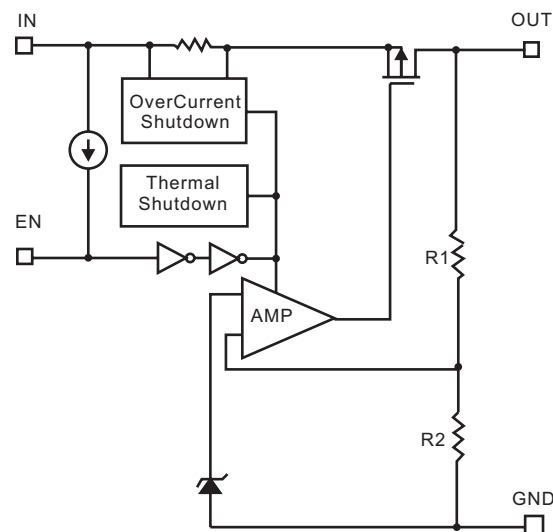
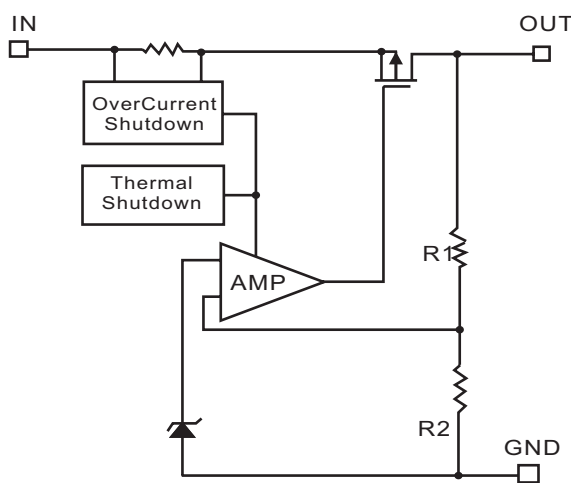



Electrical Characteristic

$V_{IN} = V_O + 0.5V$, $T_A = 25^\circ C$, $C_{IN} = 4.7\mu F$, $C_O = 2.2\mu F$, unless otherwise noted.

Parameters	Symbol	Test Conditions	MIN	TYP	MAX	UNITS	
Input Voltage Range	V_{IN}		Note 1		3.6	V	
Output Voltage Accuracy	V_O	$I_O = 100mA$	-2		2	%	
Dropout Voltage	V_{DROP}	$I_O = 2000mA$	$V_O = 0.9V$		580	750	mV
			$V_O = 1.0V$		470	650	
			$2.5V > V_O \geq 1.2V$		300	450	
			$V_O \geq 2.5V$		290	400	
Short Circuit Current	I_{SC}	$V_O < 0.3V$		3.0		A	
Quiescent Current	I_Q	$I_O = 0mA$		90	150	μA	
Ground Pin Current	I_{GND}	$I_O = 1mA$ to 2A			600	μA	
Line Regulation	LNR	$V_O \leq 2.5V, I_O = 10mA$ $V_{IN} = V_O + 0.5V$ to $V_O + 1.5V$		0.5	1	%V	
		$V_O > 2.5V, I_O = 10mA$ $V_{IN} = 3.3V$ to $3.6V$					
Load Regulation	LDR	$I_O = 1mA$ to 2A		0.5	2	%/A	
Over Temperature Shutdown	OTS			150		$^\circ C$	
Over Temperature Hysteresis	OTH			50		$^\circ C$	
Temperature Coefficient	TC			40		ppm/ $^\circ C$	
Power Supply Ripple Rejection	PSRR	$I_O = 100mA$, $V_O = 1.5V$	$f = 100Hz$		55	dB	
			$f = 1KHz$		55		
			$f = 10KHz$		35		
Output Noise	V_n	$f = 10Hz$ to $100kHz$		40		μV_{rms}	

Note1: The minimum input voltage ($V_{IN(MIN)}$) of the GL6020 is determined by output voltage and dropout voltage. The minimum input voltage is defined as:

$$V_{IN(MIN)} = V_O + V_{drop}$$

Typical Performance Characteristics

$T_A = 25^\circ C$, $C_{IN} = 4.7\mu F$, $C_O = 2.2\mu F$, unless otherwise noted.

1. Output Voltage vs Input Voltage

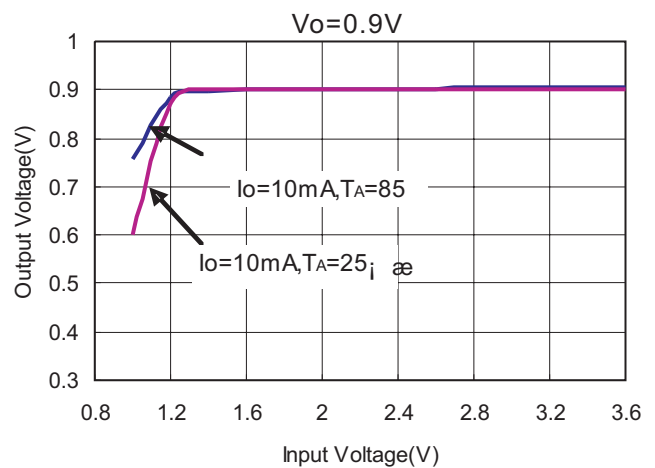
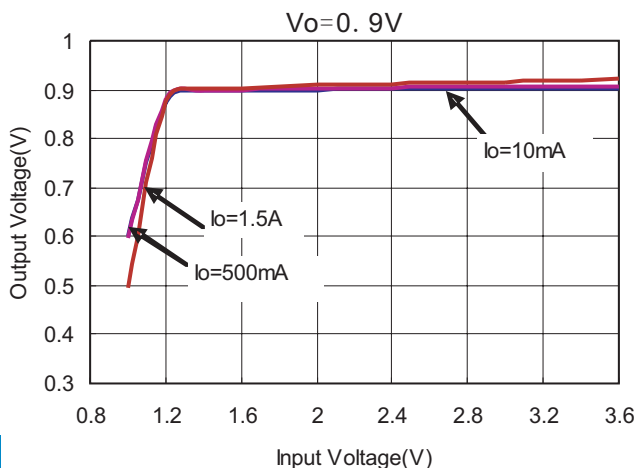

$V_O = 1.5V$

$V_O = 1.5V$



2A ULTRA LOW - DROPOUT REGULATOR

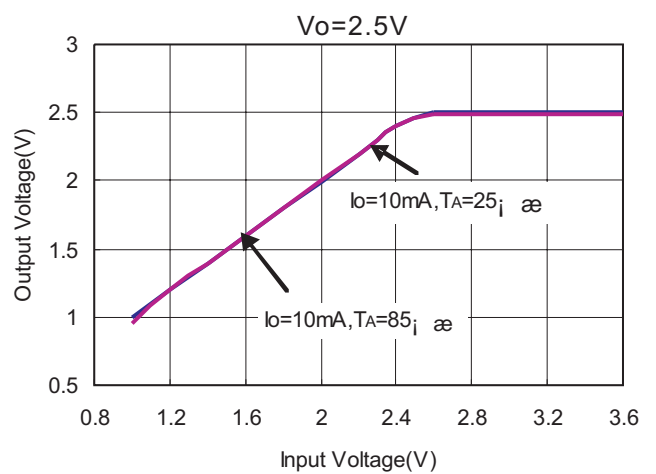
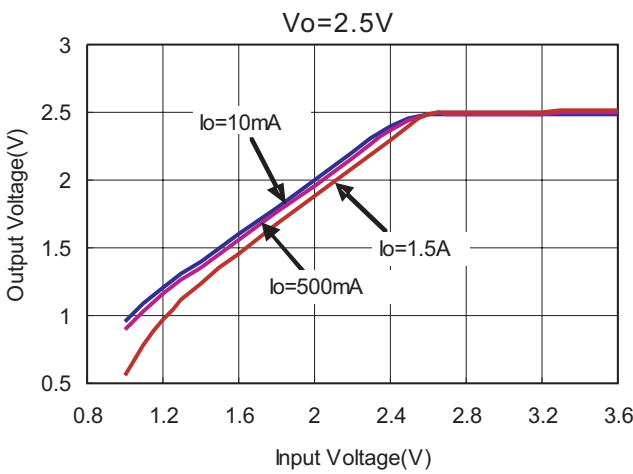
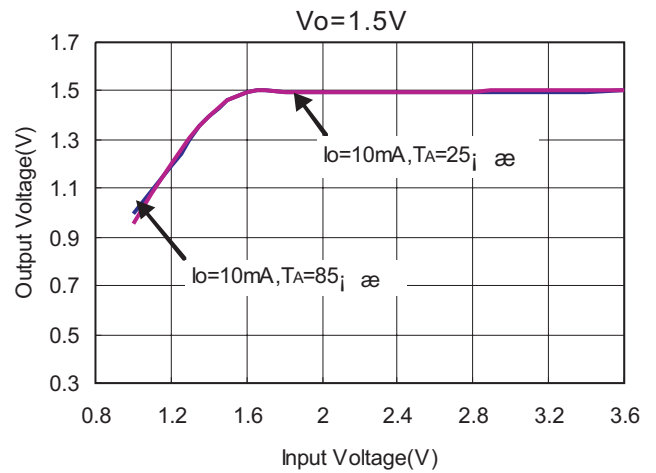
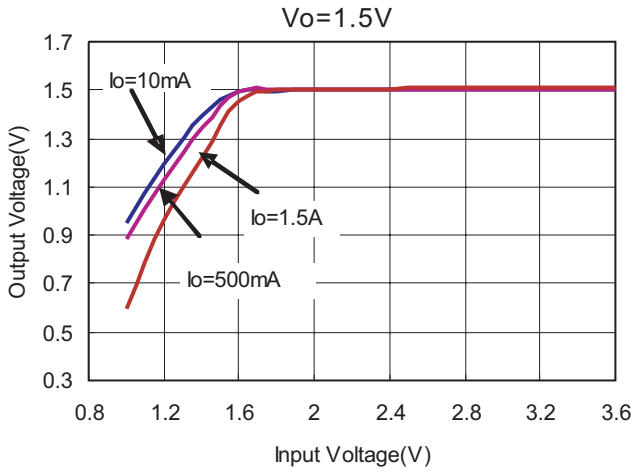

2. Output Voltage vs Output Current

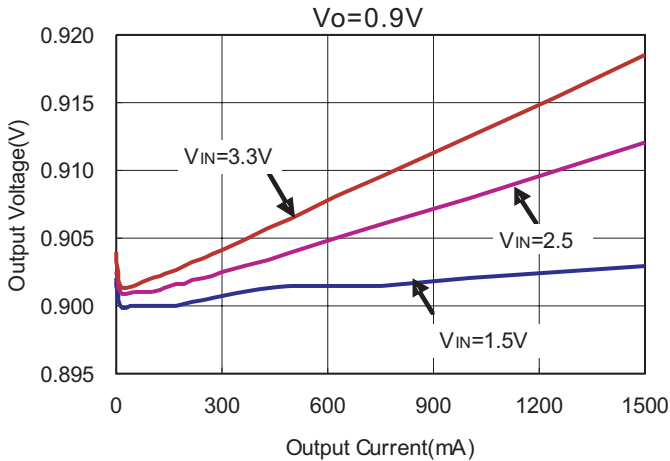

3. Output Voltage vs Temperature

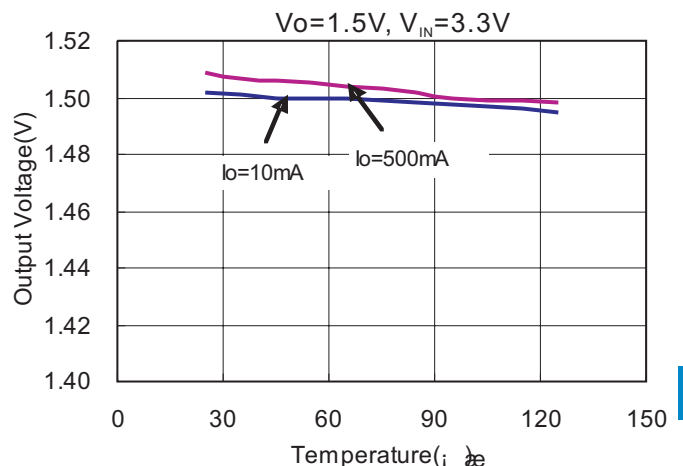
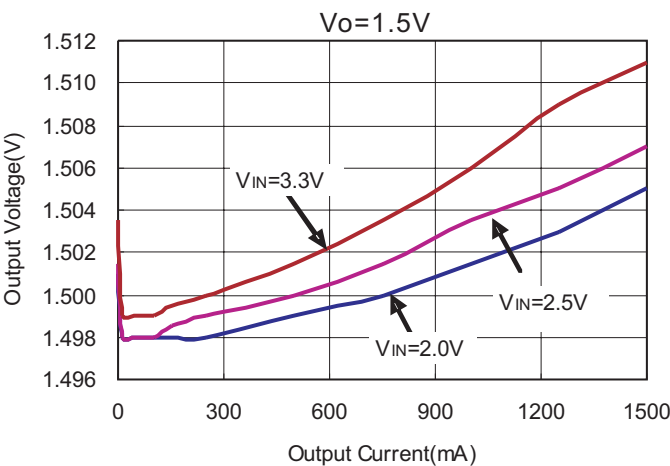
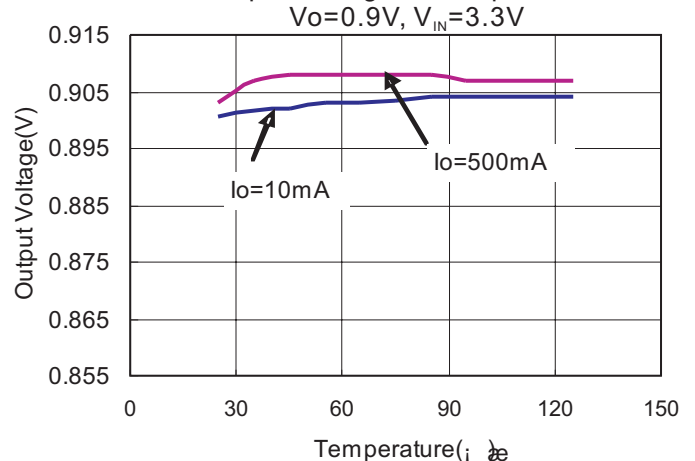

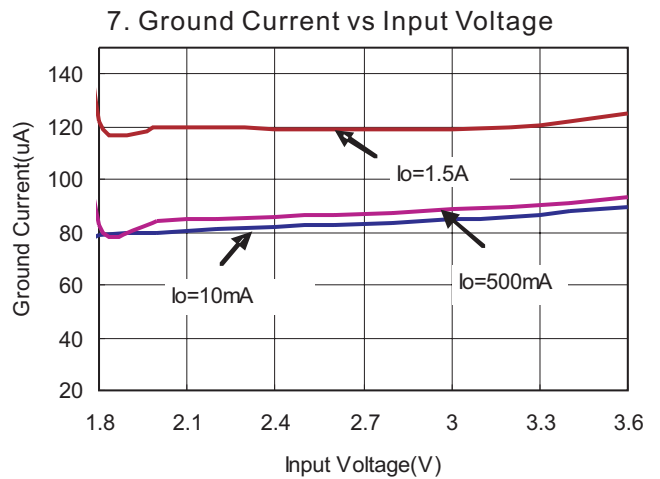
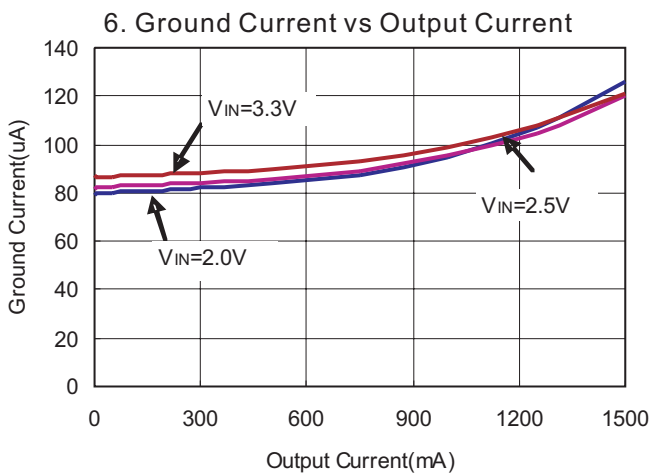
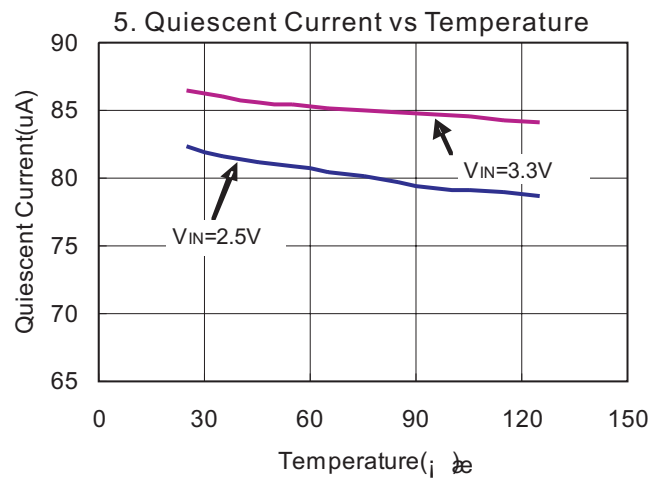
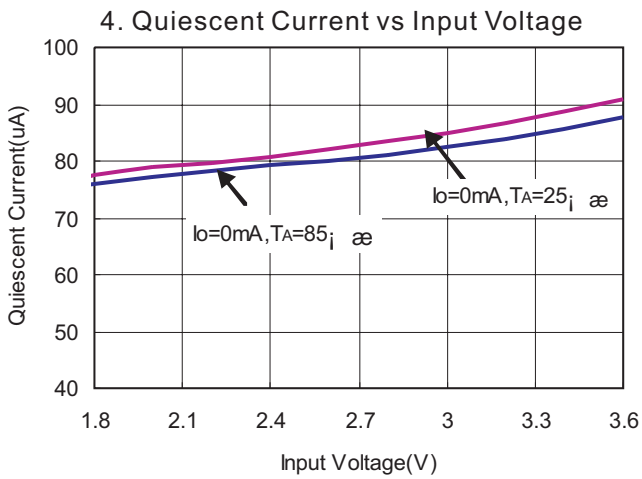
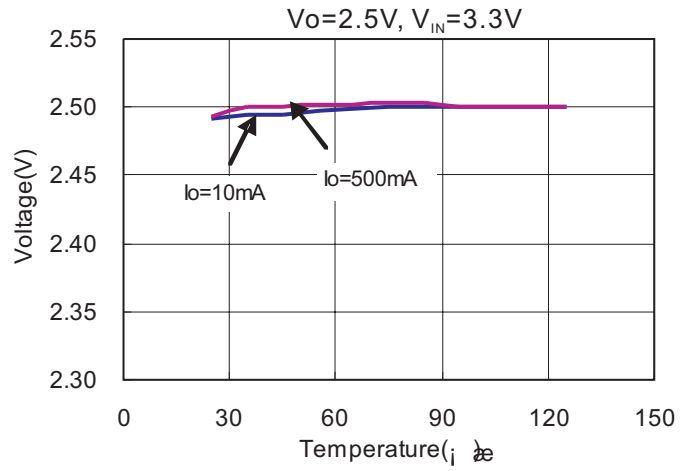
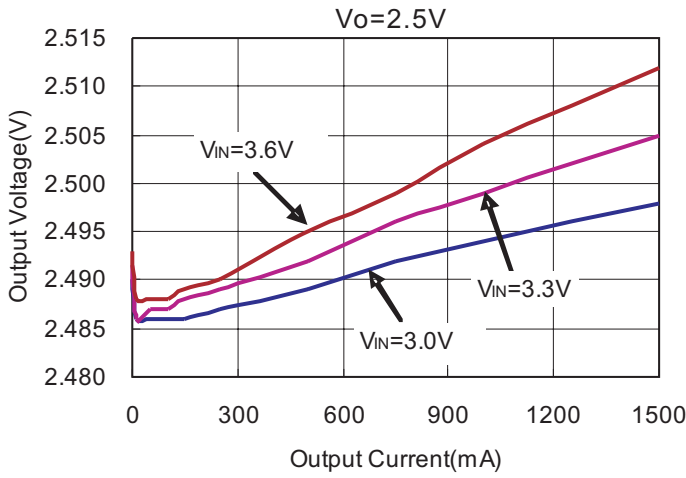



8. Dropout Voltage vs Output Current

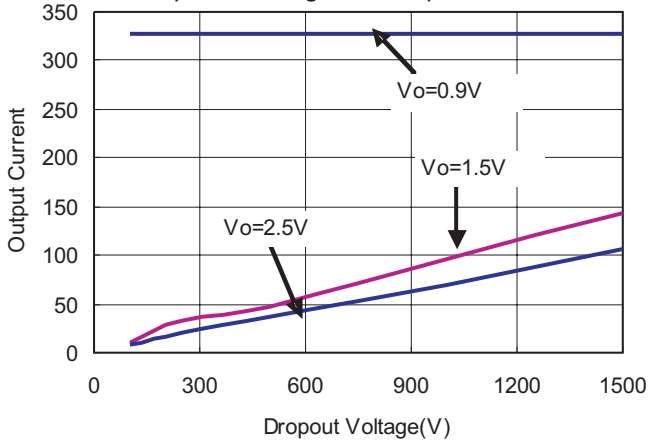

9. Dropout Voltage vs Temperature

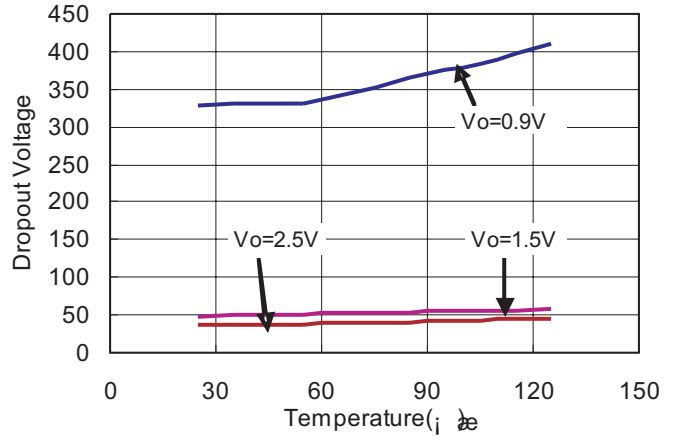

11. Load Transient Response

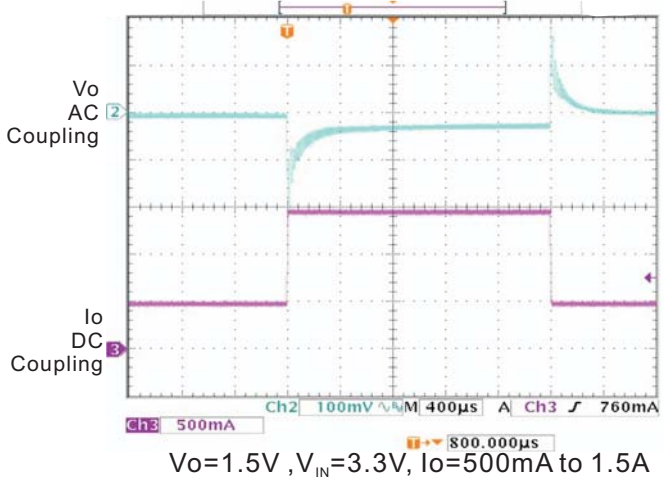
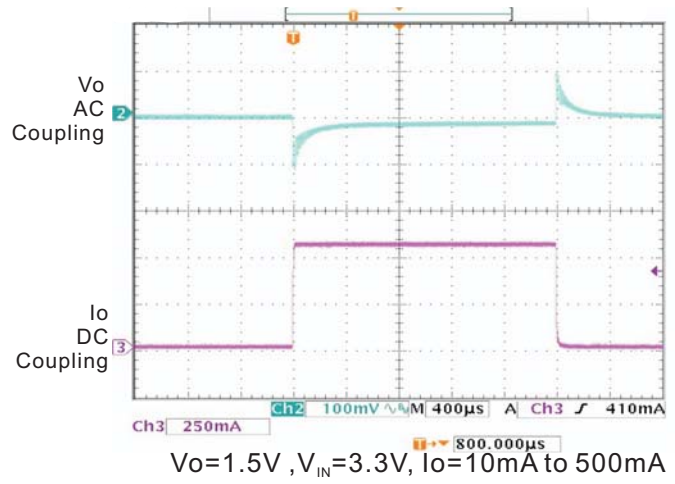
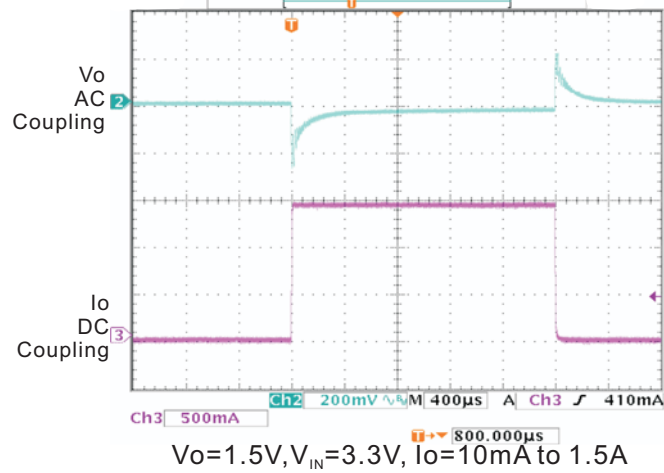

12. Line Transient Response

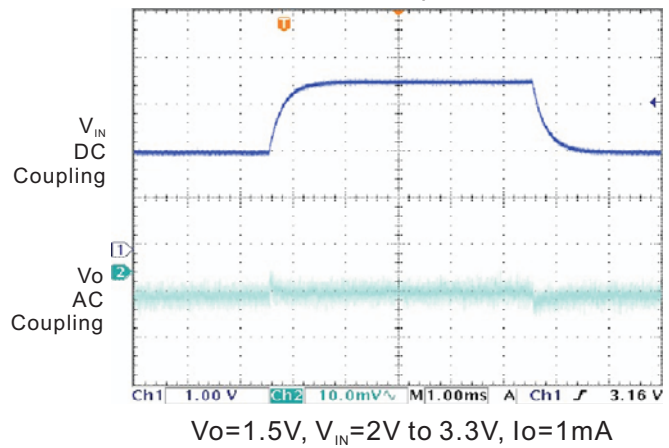



Application Information

The GL6020 family of low-dropout (LDO) regulators have several features that allow them to apply to a wide range of applications. The family operates with very low input voltage (1.4V) and low dropout voltage (typically 290mV at full load), making it an efficient stand-alone power supply or post regulator for battery or switch mode power supplies. The 2A output current make the GL6020 family suitable for powering many microprocessors and FPGA supplies. The GL6020 family also has low output noise (typically 40 μ V_{RMS} with 2.2 μ F output capacitor), making it ideal for use in telecom equipment.

External Capacitor Requirements

A 2.2 μ F or larger ceramic input bypass capacitor, connected between V_{IN} and GND and located close to the GL6020, is required for stability. A 1.0 μ F minimum value capacitor from V_O to GND is also required. To improve transient response, noise rejection, and ripple rejection, an additional 10 μ F or larger, low ESR capacitor is recommended at the output. A higher-value, low ESR output capacitor may be necessary if large, fast-rise-time load transients are anticipated and the device is located several inches from the power source, especially if the minimum input voltage of 1.4 V is used.

Regulator Protection

The GL6020 features internal current limiting, thermal protection and short circuit protection. During normal operation, the GL6020 limits output current to about 3A. When current limiting engages, the output voltage scales back linearly until the over current condition ends. While current limiting is designed to prevent gross device failure, care should be taken not to exceed the power dissipation ratings of the package. If the temperature of the device exceeds 150°C, thermal-protection circuitry will shut down. Once the device has cooled down to approximately 50°C below the high temp trip point, regulator operation resumes. The short circuit current of the GL6020 is about 2A when its output pin is shorted to ground.

Thermal Information

The amount of heat that an LDO linear regulator

generates is:

$$P_D = (V_{IN} - V_O) I_O.$$

All integrated circuits have a maximum allowable junction temperature (T_J max) above which normal operation is not assured. A system designer must design the operating environment so that the operating junction temperature (T_J) does not exceed the maximum junction temperature (T_J max). The two main environmental variables that a designer can use to improve thermal performance are air flow and external heatsinks. The purpose of this information is to aid the designer in determining the proper operating environment for a linear regulator that is operating at a specific power level.

In general, the maximum expected power (P_D (max)) consumed by a linear regulator is computed as:

$$P_{D\text{MAX}} = (V_{I(\text{avg})} - V_{O(\text{avg})}) \times I_{O(\text{avg})} + V_{I(\text{avg})} \times I_{(Q)} \quad (1)$$

Where:

- $V_{I(\text{avg})}$ is the average input voltage.
- $V_{O(\text{avg})}$ is the average output voltage.
- $I_{O(\text{avg})}$ is the average output current.
- $I_{(Q)}$ is the quiescent current.

For most LDO regulators, the quiescent current is insignificant compared to the average output current; therefore, the term $V_{I(\text{avg})} \times I_{(Q)}$ can be neglected. The operating junction temperature is computed by adding the ambient temperature (T_A) and the increase in temperature due to the regulator's power dissipation. The temperature rise is computed by multiplying the maximum expected power dissipation by the sum of the thermal resistances between the junction and the case ($R_{\theta JC}$), the case to heatsink ($R_{\theta CS}$), and the heatsink to ambient ($R_{\theta SA}$). Thermal resistances are measures of how effectively an object dissipates heat. Typically, the larger the device, the more surface area available for power dissipation so that the object's thermal resistance will be lower.



◆ **SOT-223 PACKAGE OUTLINE DIMENSIONS**

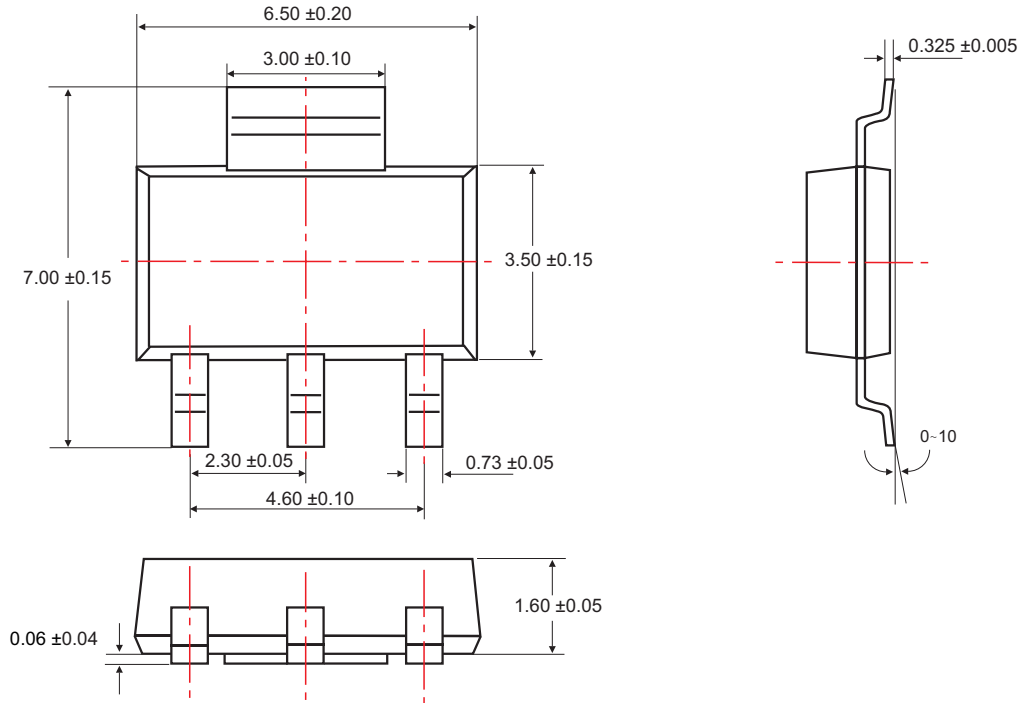

Unit: mm

◆ **SOP-8 PACKAGE OUTLINE DIMENSIONS**

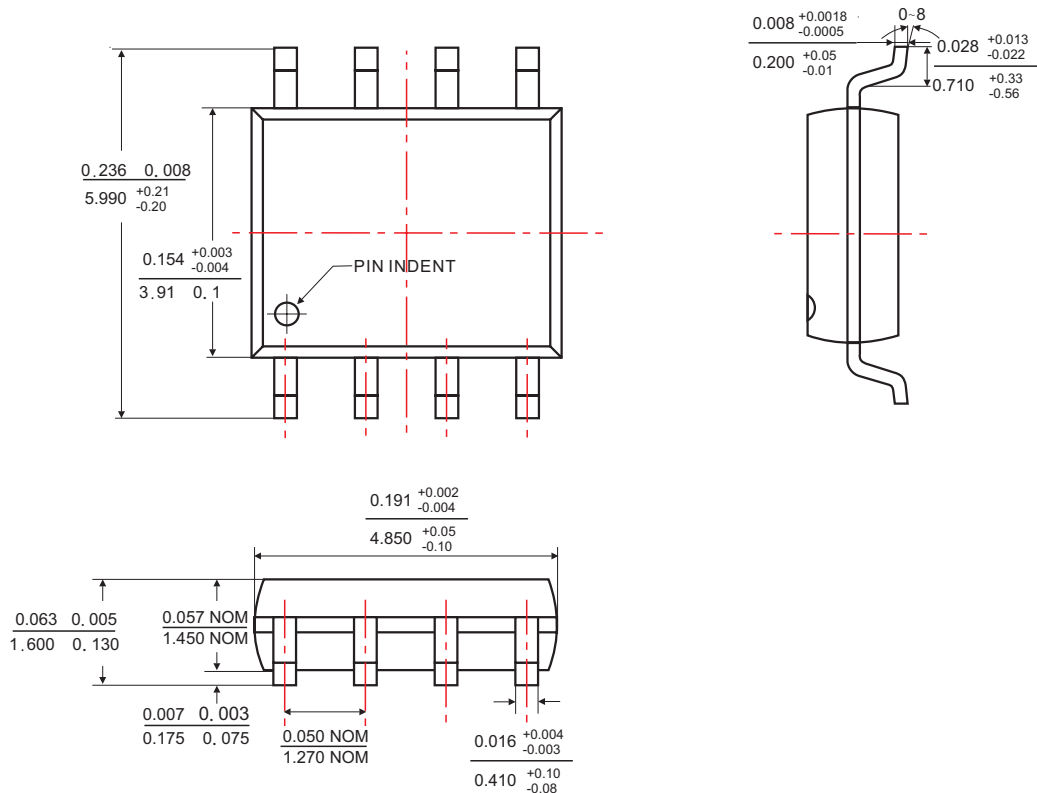

(Inches / mm)



◆ ORDERING NUMBER

