



Genesys Logic, Inc.

GL651USB

2-PORT USB KEYBOARD HUB CONTROLLER

DATA SHEET

Version 1.0, Feb. 11, 2000

Genesys Logic, Inc.

10F, No.11, Ln.3, Tsao Ti Wei, Shenkeng, Taipei, Taiwan

Tel: 886-2-2664-6655 Fax: 886-2-2664-5757

<http://www.genesyslogic.com>



GL651USB USB KEYBOARD HUB CONTROLLER

1 FEATURES

- High performance and low-cost solution for USB keyboard with hub solution
- USB Specification Compliance
 - Conforms to USB specification Rev. 1.1
 - Conforms to HID Class specification Rev. 1.0
 - Supports 1 device address for hub, 1 device address for keyboard
 - Supports 2 endpoints of hub, 3 endpoints for keyboard
- 8-bit micro-processor
 - RISC-like architecture
 - USB optimized instruction set
 - Single cycle instruction execution
 - Operation Speed: DC to 24 MHz clock input
 - Performance: 12 MIPS @ 24MHz
- I/O ports
 - Up to 20 output pins for key matrix drive pin
 - Up to 8 input pins for key matrix sense pin
 - Up to 5 I/O pins with LED drive capability : 3 for keyboard, 2 for hub
 - Up to 8 general purpose I/O pins for customization
- Internal memory
 - 80 bytes of RAM
 - 3.25K × 14 of program ROM
 - larger size of ROM makes it possible for customization
- On-chip 3.3v output
 - No external regulator required
- Integrated USB transceiver
- 12 MHz external clock
- Improved output drivers with slew-rate control to reduce EMI
- Internal power-on reset(POR)
- Internal power-fail detector for ESD recovery
- Support suspend/normal mode power management
- Remote wakeup is supported for both keyboard and hub
- Support power management for downstream port devices
- Automatic switching between self/bus powered mode
- Smart LED traffic indicator
 - The higher data traffic flows through the hub downstream port, the higher frequency that port's LED will blink.
- 100 pin LQFP package for demo, COB structure is supported



GL651USB USB KEYBOARD HUB CONTROLLER

2 FUNCTION OVERVIEW

The GL651USB is an USB keyboard hub with 1 upstream port and 2 downstream ports. It integrates USB keyboard and hub in a single chip to add extra value to traditional keyboard and lower its total cost. The GL651USB uses an 8-bit RISC-like uC to encode/decode the host commands and to decode the keyboard matrix data. Its 8 general-purpose I/O(GPIO) pins and the uC-based structure make the implementation of customization very easy. The GL651USB supports 20 drive pins to meet the diversity of keyboard matrix. Besides, 5 GPIO pins support the LED driving, 3 for keyboard and 2 for hub. Hence vendors can decide whether or not to enable the hub LED function easily. For giving more design flexibility, the power supply of GL651USB can be switched automatically: self-power or bus-power. In the same way, vendors can pullup/pulldown the SELF pin to support only self/bus power if they have cost issue. The GL651USB can be configured as ganged/individual mode for hub functions by strapping through pullup/pulldown the SUSPND pin. To prevent from abnormal current consumption of downstream port devices, the GL651USB supplies power enable flags by reading the over-current flags. By hub LED, The GL651USB also supports smart traffic indication, i.e., the higher data traffic flows through one port, the higher frequency of that port's LED blinks. In order to minimize the power consumption, the GL651USB will turn LED off and stop the clock automatically when it is suspended.

The GL651USB is the most featured and flexible product for those vendors who are looking for “USB Keyboard with Hub” solution. Besides, vendors can easily modify their board circuits to meet their own requirement if they have product differentiation or cost issues. Further more, if vendor has the requirement of saving their package cost, COB component also can be supplied by request.



GL651USB USB KEYBOARD HUB CONTROLLER

3 PIN DEFINITIONS AND DESCRIPTIONS

● GL651USB

Pin No.	Name	I/O	Description
3	GND	-	Analog ground
5	DM2	I/O	Downstream port 2 USB data-
7	DP2	I/O	Downstream port 2 USB data+
9	DM0	I/O	Upstream port USB data-
11	DP0	I/O	Upstream port USB data+
13	VCP	-	3.3V output
15	DM1	I/O	Downstream port 1 USB data-
17	DP1	I/O	Downstream port 1 USB data+
19	VDD	-	VCC(5V)
21	NUMLOCK	I/O	Keyboard Num LOCK LED Also can be used as general purpose pin GPIO0
23	CAPSLOCK	I/O	Keyboard Caps Lock LED Also can be used as general purpose pin GPIO1
25	SCLOCK	I/O	Keyboard Scroll Lock LED Also can be used as general purpose pin GPIO2
27	TEST	I	Test mode input: (internal pull low) For 48 Mhz oscillator clock input, pull high For 12 Mhz crystal clock input, floating
29	DRV1	O	Key matrix drive output 1
31	DRV2	O	Key matrix drive output 2
32	DRV3	O	Key matrix drive output 3
34	DRV4	O	Key matrix drive output 4
35	DRV5	O	Key matrix drive output 5
37	DRV6	O	Key matrix drive output 6
38	DRV7	O	Key matrix drive output 7
40	DRV8	O	Key matrix drive output 8
41	DRV9	O	Key matrix drive output 9
43	DRV10	O	Key matrix drive output 10
44	DRV11	O	Key matrix drive output 11
46	DRV12	O	Key matrix drive output 12
47	DRV13	O	Key matrix drive output 13
49	DRV14	O	Key matrix drive output 14
50	DRV15	O	Key matrix drive output 15
52	GND	-	GND
54	DRV16	O	Key matrix drive output 16
56	DRV17	O	Key matrix drive output 17
58	DRV18	O	Key matrix drive output 18
60	DRV19	O	Key matrix drive output 19
62	DRV20	O	Key matrix drive output 20
64	SUSPND	I/O	Suspend indication output and individual setting input Pull low: individual mode. Pull high: ganged mode
66	GPIO7	I/O	General purpose pin 7
68	GPIO6	I/O	General purpose pin 6
70	VDD	-	VCC(5V)
72	GPIO5	I/O	General purpose pin 5



GL651USB USB KEYBOARD HUB CONTROLLER

73	GPIO4	I/O	General purpose pin 4
75	GPIO3	I/O	General purpose pin 3
76	RESET	I	Reset input
78	SELF	I	1: self-powered. 0: bus-powered
79	SENSE1	I	Keyboard matrix sense input 1
81	SENSE2	I	Keyboard matrix sense input 2
82	SENSE3	I	Keyboard matrix sense input 3
84	SENSE4	I	Keyboard matrix sense input 4
85	SENSE5	I	Keyboard matrix sense input 5
87	SENSE6	I	Keyboard matrix sense input 6
88	SENSE7	I	Keyboard matrix sense input 7
90	SENSE8	I	Keyboard matrix sense input 8
91	PWRENB1#	O	Power enable for downstream port 1
93	PWRENB2#	O	Power enable for downstream port 2
94	OVCUR1#	I	Over current flag for downstream port1
96	OVCUR2#	I	Over current flag for downstream port2
97	XTAL2	O	Ceramic resonator or crystal out
99	XTAL1	I	Ceramic resonator or crystal in

Note 1: “#” means low active

Table 1 GL651USB Pin Definitions and Descriptions

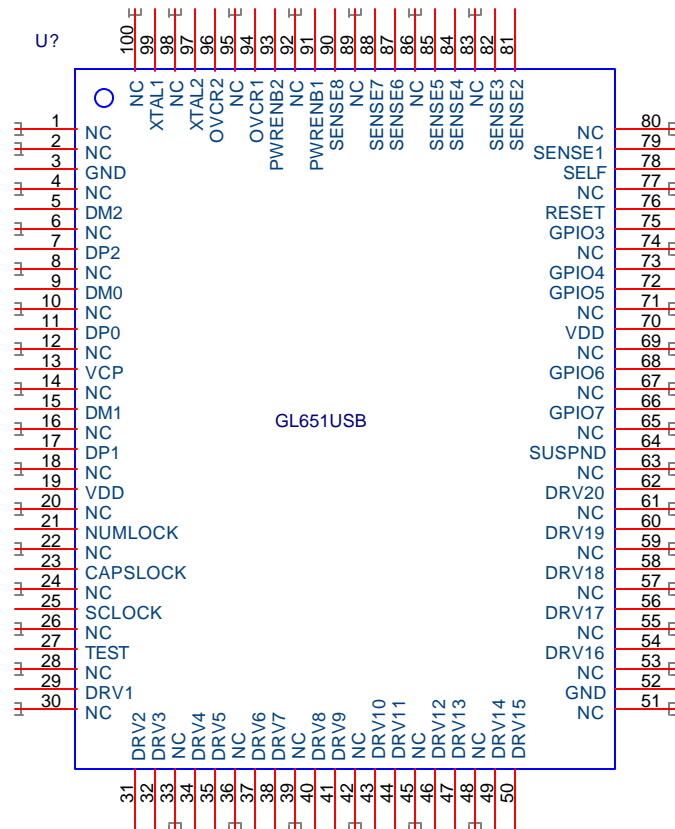

4 Functional description

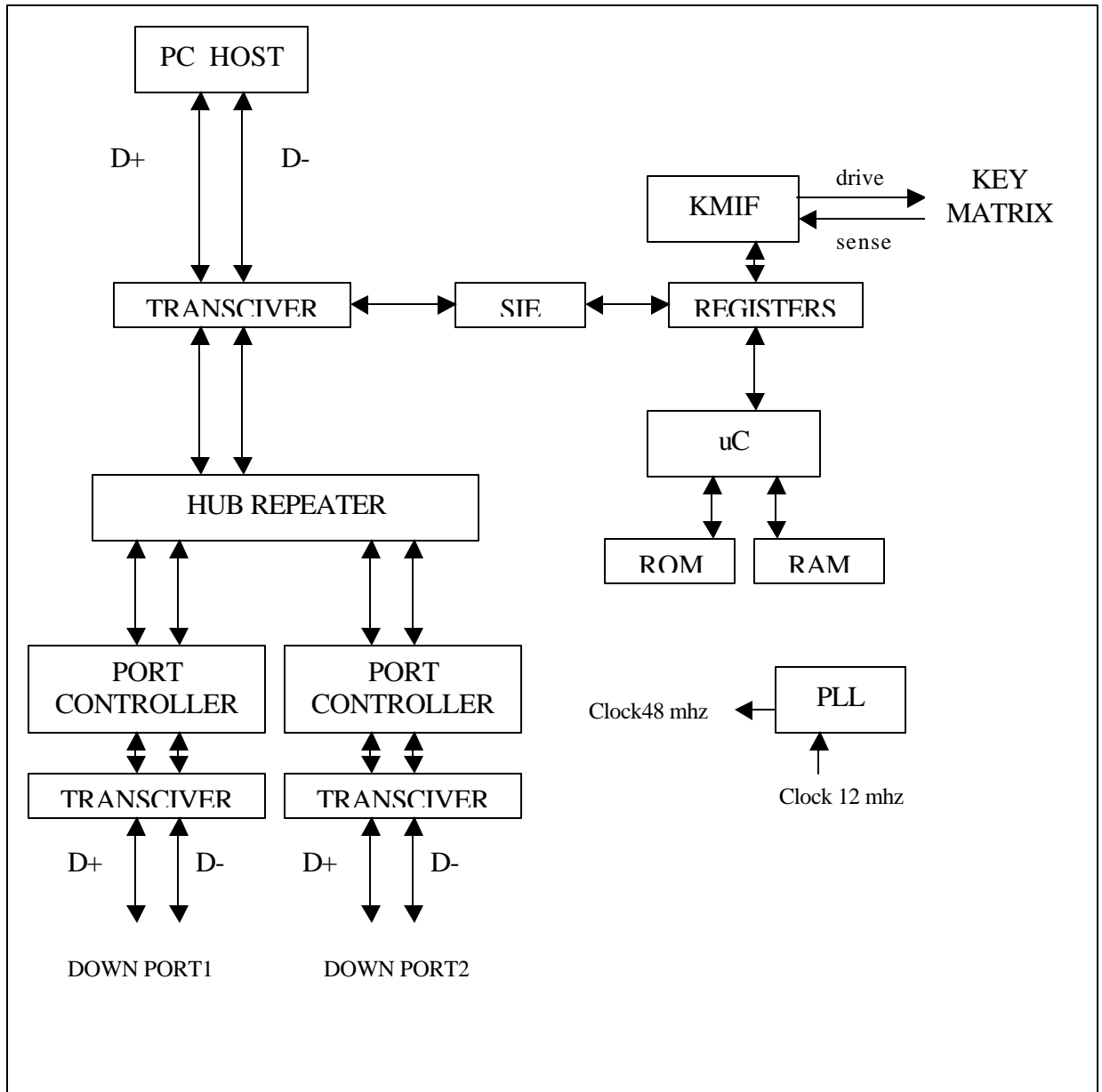



GL651USB USB KEYBOARD HUB CONTROLLER

- TRANSCIVER:** TRANSCIVER is the analog circuits, which takes care of the electrical characteristics of USB.
- SIE:** SIE is the serial interface engine. The main responsibility of SIE is to code/decode USB protocol. SIE guarantee the GL651USB always function in a correct state.
- KMIF:** KMIF is the interface of key matrix and GL651USB. KMIF drives the key matrix and sense the input. The sensed data is then output to the registers, which provide the uC to judge the pressed key.
- REGISTERS:** REGISTERS is the interface of hardware and software. The used registers will be listed in the later section.
- REPEATER:** REPEATER is the kernel of hub. It repeats the data accurately from the upstream port to the downstream port, and vice versa.
- PORT CONTROLLER:** Each downstream port of hub needs a PORT CONTROLLER respectively. It monitors the state of the port.
- PLL:** PLL extracts 48 Mhz clock from input 12 Mhz clock. This 48 Mhz clock is used to generate USB clock in the digital PLL circuit.

5 REGISTER SUMMARY

MNEMONIC	OFFSET	DESCRIPTION
DEVCTL	00h	Device control register
EVTFLG_1	01h	USB function interrupt flag
EVTFLG_2	02h	USB function interrupt flag
RXCTL0_HB	03h	Endpoint 0 RX control of hub
RXCTL0_KB	04h	Endpoint 0 RX control of keyboard
TXCTL0_HB	05h	Endpoint 0 TX control of hub
TXCTL0_KB	06h	Endpoint 0 TX control of keyboard
TXCTL123	07h	Endpoint 1,2, and 3 TX control
FFDAT0_HB	08h	Data buffer (FIFO) for endpoint 0 of hub
FFDAT0_KB	09h	Data buffer (FIFO) for endpoint 0 of keyboard
FFDAT123	0Ah	Data buffer (FIFO) for endpoint 1, 2, and 3
BUFCTL	0Bh	Data buffer control register
DRVSEL	0Ch	DRV1 ~ DRV18 select
SENSE	0Dh	SENSE1 ~ SENSE8 input
ENDP_PORT_SEL	0Eh	Endpoint selected and hub port to be configured
HUB_STAT_CHG	0Fh	Hub status and status change indicator
PORT_STATUS	10h	Hub ports status indicator
BUS_PORT_DATA	11h	Hub ports status change indicator
HOST_CMD	12h	Host command to HUB
ENP2_IND	13h	Hub interrupt indicator



GL651USB USB KEYBOARD HUB CONTROLLER

LEDCTL	14h	LED control flag
KBSTUS	15h	Keyboard address and configuration status
REV	16h	Chip revision
HUBSTUS	17h	USB hub address and configuration status
MODESEL	18h	Strapping mode register

R/O: read only
 R/W: read / write
 R/WIC: read / write "1" to clear
 W/O: write only

DEVCTL (offset 00, default = 00h)

R/W		R/O	R/W	R/W	R/W	R/O	R/W
USBRDY	--	GANG	RW_KB	RW_HUB	SFRAME	SELF	PWRDN

USBRDY : 0 - USB interface is not ready. The device drives USB with SE0.
 1 - USB interface is ready. The device stops driving USB with SE0.
 After power-on reset, USBRDY is cleared and the device looks like disconnected. Set USBRDY to '1' to enable USB interface.

GANG : 0 - Individual mode. 1 - gang mode.

RW_KB : remote wakeup ability enable for keyboard.

RW_HUB : remote wakeup ability enable for hub.

SFRAME : short frame option for test purpose
 Set SFRAME to '1' will shorten frame length to 1/15 ms. It is to shorten the time required for test.

SELF : 0 - HUB is bus powered.
 1 - HUB is self-powered.

PWRDN : power down mode

In suspend state, firmware can set PWRDN to put the controller into power down mode. In this mode, the embedded micro-controller and most internal activities are frozen.

EVTFLG _1 (offset 01, default = 00h)

	R/WIC	R/WIC	R/WIC	R/WIC	R/WIC	R/WIC	R/WIC
--	EP3TX	EP2TX	EP1TX	EP0TXKB	EP0TXHB	EP0RXKB	EP0RXHB

Interrupt event flag –

EP0RXHB : a SETUP or OUT transaction to endpoint 0 of hub is accepted

EP0RXKB : a SETUP or OUT transaction to endpoint 0 of keyboard is accepted

EP0TXHB : USB host controller accepts hub data transmitted via endpoint 0.

EP0TXKB : USB host controller accepts keyboard data transmitted via endpoint 0.

EPnTX : USB host controller accepts data transmitted via endpoint n



GL651USB USB KEYBOARD HUB CONTROLLER

EVTFLG **_2** (offset 02, default = 00h)

			<i>R/WIC</i>	<i>R/WIC</i>	<i>R/WIC</i>	<i>R/WIC</i>	<i>R/WIC</i>
--	--	--	WAKEUP	SUSPD	USBRST	SOF	C_LCPWR

Interrupt event flag –

- SUSPD : the controller goes into suspend state
- WAKEUP : remote wakeup is detected when global suspended
- USBRST : End of USB reset
- SOF : SOF detected or generated by HUB timer.
- C_LCPWR : POWER source change.

RXCTL0_HB (offset 03, default = 40h)

<i>R/W</i>	<i>R/O</i>	<i>R/O</i>	<i>R/O</i>	<i>R/O</i>	<i>R/O</i>	<i>R/O</i>	<i>R/O</i>
RXDIS	RXSETUP	RXOUT	RXSEQ	RXCNT3	RXCNT2	RXCNT1	RXCNT0

RXCTL0 of hub.

Status of endpoint 0 receiving –

- RXCNT3~0 : EP0 received data byte count.
- RXSEQ : 1 - The received data PID is DATA1
 0 - The received data PID is DATA0
- RXOUT : 1 - The received token PID is OUT.
- RXSETUP : 1 - The received token PID is SETUP.
- RXDIS : 0 - Endpoint 0 FIFO is empty and ready for data-packet receiving.
 1 - Endpoint 0 FIFO is filled with data and will reject the new-coming data packet.

If RXDIS = 1, the device will not accept an OUT transaction addressed to it, and will respond with a NAK to an error-free transaction. Hardware will automatically set RXDIS after a successful receiving. After processing, the micro-controller should clear RXDIS to enable next data-packet receiving or free FF0 for filling of the data to transmit. Note that a SETUP transaction addressed to the device is always accepted even though RXDIS = 1.

RXCTL0_KB (offset 04, default = 40h)

<i>R/W</i>	<i>R/O</i>	<i>R/O</i>	<i>R/O</i>	<i>R/O</i>	<i>R/O</i>	<i>R/O</i>	<i>R/O</i>
RXDIS	RXSETUP	RXOUT	RXSEQ	RXCNT3	RXCNT2	RXCNT1	RXCNT0

RXCTL0 of keyboard. Definition of each bit is the same as RXCTL0_HB.

TXCTL0_HB (offset 05, default = 00h)

	<i>R/W</i>	<i>R/W</i>	<i>R/W</i>	<i>R/W</i>	<i>R/W</i>	<i>R/W</i>	<i>R/W</i>
--	EPOSTL	EPOOE	EPOSEQ	EPOCNT3	EPOCNT2	EPOCNT1	EPOCNT0

TXCTL0 of hub.

Endpoint 0 transmit setting –

- EPOCNT3~0 : number of data bytes to transmit
- EPOOE : enable data transmit
 1 – ready to transmit data packet
 0 – not ready to transmit data packet (default)
- EPOSEQ : data packet type
 0 –DATA0
 1 –DATA1
- EPOSTL : set endpoint 0 stall
 1 – EP0 will respond to USB host controller with STALL packet
 EPOSTL will be automatically cleared when a setup transaction is accepted.

After filling the data-to-transmit into FF0, the micro-controller should setup this register to enable endpoint 0 data transmit. If EPOOE = 0, endpoint 0 will respond to a valid IN transaction



GL651USB USB KEYBOARD HUB CONTROLLER

with a NAK. EP0OE will be automatically cleared after a successful transmission, or when endpoint 0 has incidentally accepted another SETUP or OUT transaction.

TXCTL0_KB (offset 06, default = 00h)

	<i>R/W</i>	<i>R/W</i>	<i>R/W</i>	<i>R/W</i>	<i>R/W</i>	<i>R/W</i>	<i>R/W</i>
--	EP0STL	EP0OE	EP0SEQ	EP0CNT3	EP0CNT2	EP0CNT1	EP0CNT0

TXCTL0 of hub. Definition of each bit is the same as TXCTL0_HB.

TXCTL123 (offset 07, default = 00h)

	<i>R/W</i>	<i>R/W</i>	<i>R/W</i>	<i>R/W</i>	<i>R/W</i>	<i>R/W</i>	<i>R/W</i>
--	EPnSTL	EPnOE	EPnSEQ	EPnCNT3	EPnCNT2	EpnCNT1	EpnCNT0

Endpoint n(1~3) transmit setting –

EPnCNT3~0 : number of data bytes to transmit.

EPnOE : enable data transmit

1 – ready to transmit data packet

0 – not ready to transmit data packet (default)

EPnSEQ : data packet type

0 –DATA0

1 –DATA1

EPnSTL : set endpoint n stall

1 – EPn will respond to USB host controller with STALL packet

0 – default

After preparing the data to transmit, the micro-controller should setup this register to enable endpoint n data transmit. If EPnOE = 0, endpoint n will respond to a valid IN transaction with a NAK. After a successful transmission, the device will automatically clear EPnOE. EPSEL1~3 must be set before setting TXCTL123.

FFDAT0_HB (offset 08, default = 00h)

<i>R/W</i>	<i>R/W</i>	<i>R/W</i>	<i>R/W</i>	<i>R/W</i>	<i>R/W</i>	<i>R/W</i>	<i>R/W</i>
FFD7	FFD6	FFD5	FFD4	FFD3	FFD2	FFD1	FFD0

FFDAT0 of hub.

Each FFDAT0 read/write will automatically increase the FIFO pointer, which is a 3-bit circular counter, by 1. Writing FPRST0 with '1' (in BUFCTL) will reset the pointer. Note that to fill FFDAT0, RXDIS (in RXCTL0) must be first cleared.

FFDAT0_KB (offset 09, default = 00h)

<i>R/W</i>	<i>R/W</i>	<i>R/W</i>	<i>R/W</i>	<i>R/W</i>	<i>R/W</i>	<i>R/W</i>	<i>R/W</i>
FFD7	FFD6	FFD5	FFD4	FFD3	FFD2	FFD1	FFD0

FFDAT0 of hub. Definition of each bit is the same as FFDAT0_HB.

FFDAT123 (offset 0A, default = 00h)

<i>R/W</i>	<i>R/W</i>	<i>R/W</i>	<i>R/W</i>	<i>R/W</i>	<i>R/W</i>	<i>R/W</i>	<i>R/W</i>
FFD7	FFD6	FFD5	FFD4	FFD3	FFD2	FFD1	FFD0

Each FFDAT123 read/write will automatically increase the FIFO pointer, which is a 3-bit circular counter, by 1. Writing FPRST1 with '1' (in BUFCTL) will reset the pointer. EPSEL1~3 must be set before setting FFDAT123.

BUFCTL (offset 0B)

						<i>R/W</i>	<i>R/W</i>
--	--	--	--	--	--	FPRST1	FPRST0

Data buffer control –

FPRST[1:0] : Reset FIFO pointer of FIFO 0~3.



GL651USB USB KEYBOARD HUB CONTROLLER

Before FFRST[1:0] is used, ENDP[1~3] must have been set.

DRVSEL (offset 0C)

	R/W	R/W	R/W	R/W	R/W	R/W	R/W
--	INVDRV	DRVOE	DRV4	DRV3	DRV2	DRV1	DRV0

DRV[4:0] : Select one of DRV1 to DRV20 port to drive if DRVOE is set.
 5'h00 ~ 5'h11 stand for DRV1 to DRV20.
NOTE: 5'h14 ~ 5'h1f are invalid.

DROVE : DRV[4:0] output enable. ONLY when DRVOE is set can DRV[4:0] drive out.

INVDRV : Set this bit to drive all DRV1-20 to low except the selected drive pin

SENSE (offset 0D, default = 00h)

R/O	R/O	R/O	R/O	R/O	R/O	R/O	R/O
SENSE8	SENSE7	SENSE6	SENSE5	SENSE4	SENSE3	SENSE2	SENSE1

PORT_ENDP_SEL (offset 0E, default = 00h)

	R/W	R/W	R/W		R/W	R/W	R/W
--	PORTSEL 3	PORTSEL 2	PORTSEL 1	--	EPSEL3	EPSEL2	EPSEL1

Port under host command or Endpoint under host request

PORTSEL1 1'b1 – port 1 selected

PORTSEL2 1'b1 – port 2 selected

PORTSEL3 1'b1 – port 3 selected

EPSEL3 1'b1 – endpoint 3 is selected

EPSEL2 1'b1 – endpoint 2 is selected

EPSEL1 1'b1 – endpoint 1 is selected

Before FFDAT123 and TXCTL123 is used, EPSEL1~3 must have been set.

HUB_STAT_CHG (offset 0F, default = 00h)

R/O	R/O					R/O	R/O
LCPWR	OVCUR	--	--	--	--	C_LCPWR	C_OVCUR

HUB status and status change

LCPWR : HUB local power status
 1'b0 – local power good
 1'b1 – local power lost

OVCUR : HUB over current indicator
 1'b0 – No over-current condition currently exists
 1'b1 – A hub over-current condition exists

C_LCPWR : Local power status change
 1'b0 – No change has occurred to local power status
 1'b1 – local power status has changed

C_OVCUR : HUB over current indicator change
 1'b0 – No change has occurred to the over-current indicator
 1'b1 – Hub over-current indicator has changed

PORT_STATUS (offset 10, default = 00h)

R/O	R/O		R/O	R/O	R/O	R/O	R/O
PT_LOW_SPD	PT_PWR	--	PT_RST	PT_OVCUR	PT_SUS	PT_EN	PT_CON

Port status indicator:



GL651USB USB KEYBOARD HUB CONTROLLER

PT_LOW_SPD : 1'b0 – full speed device connected, 1'b1 – low speed device connected.

PT_PWR : 1'b0 – port is in power off state, 1'b1 – port is not in power off state

PT_RST : 1'b0 – Reset signaling not asserted, 1'b1 – Reset signaling asserted

PT_OVCCR : 1'b0 – No over-current condition occurred on this port
1'b1 – An over-current condition exists on this port

PT_SUS : 1'b0 – port not suspended, 1'b1 – port suspended or resuming

PT_EN : 1'b0 – port is disabled, 1'b1 – port is enabled

PT_CON : 1'b0 – No device is present, 1'b1 – A device is present on this port

BUS_PORT_DATA (offset 11, default = 00h)

R/O	R/O		R/O	R/O	R/O	R/O	R/O
VP	VM	--	C_PT_RST	C_PT_OVCCR	C_PT_SUS	C_PT_EN	C_PT_CON

Bus state and Port status change indicator:

VP : VP state on the downstream port

VM : VM state on the downstream port

C_PT_RST : 1'b0 – No change, 1'b1 – Reset complete

C_PT_OVCCR : 1'b0 – No change has occurred to over-current indicator
1'b1 – over-current indicator has changed

C_PT_SUS : 1'b0 – No change, 1'b1: – Resume complete

C_PT_EN : Set to one when a port is disabled because of a Port_error condition

C_PT_CON : 1'b0 – No change has occurred to current connect status
1'b1 – Current connect status has changed

HOST_CMD (offset 12, default = 0Fh)

W/O	W/O	W/O	W/O	W/O	W/O	W/O	W/O
HB_CMD3	HB_CMD2	HB_CMD1	HB_CMD0	PT_CMD3	PT_CMD2	PT_CMD1	PT_CMD0

Host command to the hub:

PT_CMD3~0 : 4'h0 –SetPortFeature(PORT_SUSPEND)
4'h1 –SetPortFeature(PORT_RESET)
4'h2 –SetPortFeature(PORT_POWER)
4'h3 –ClearPortFeature(PORT_ENABLE)
4'h4 –ClearPortFeature(PORT_SUSPEND)
4'h5 –ClearPortFeature(PORT_POWER)
4'h6 –ClearPortFeature(C_PORT_RESET)
4'h7 –ClearPortFeature(C_PORT_OVER_CURRENT)
4'h8 –ClearPortFeature(C_PORT_SUSPEND)
4'h9 –ClearPortFeature(C_PORT_ENABLE)
4'hA –ClearPortFeature(C_PORT_CONNECTION)

HB_CMD3 : 1'b1 –SetHubFeature(C_HUB_LOCAL_POWER)

HB_CMD2 : 1'b1 –SetHubFeature(C_HUB_OVER_CURRENT)

HB_CMD1 : 1'b1 –ClearHubFeature(C_HUB_LOCAL_POWER)

HB_CMD0 : 1'b1 –ClearHubFeature(C_HUB_OVER_CURRENT)

ENP2_IND (offset 13, default = 00h)

				R/O	R/O	R/O	R/O
--	--	--	--	PT3	PT2	PT1	HUB



GL651USB USB KEYBOARD HUB CONTROLLER

Endpoint2 (HUB) interrupt change indicator

LEDCTL (offset 14, default = 00h)

		<i>R/W1C</i>	<i>R/W1C</i>			<i>R/W1C</i>	<i>R/W1C</i>
--	--	P2_ON	P1_ON	--	--	P2_TRX	P1_TRX

Hub LED control flag:

- P1_TRX : upstream traffic happens on downstream port 1
- P2_TRX : upstream traffic happens on downstream port 2
- P1_ON : if 1'b1, LED is always on, otherwise, judge according to TRXFLAG register.
- P2_ON : if 1'b1, LED is always on, otherwise, judge according to TRXFLAG register.

KBSTUS (offset 15, default = 0Fh)

<i>R/W</i>	<i>R/W</i>	<i>R/W</i>	<i>R/W</i>	<i>R/W</i>	<i>R/W</i>	<i>R/W</i>	<i>R/W</i>
KCONFIG	KBADR6	KBADR5	KBADR4	KBADR3	KBADR2	KBADR1	KBADR0

Keyboard address and keyboard configuration.

REV (offset 16, default = current revision)

<i>R/O</i>	<i>R/O</i>	<i>R/O</i>	<i>R/O</i>	<i>R/O</i>	<i>R/O</i>	<i>R/O</i>	<i>R/O</i>
REV7	REV6	REV5	REV4	REV3	REV2	REV1	REV0

This register returns current silicon revision number of this device.
Current revision is 8'h11. (Revision 1.1)

HUBSTUS (offset 17, default = 00h)

<i>R/W</i>	<i>R/W</i>	<i>R/W</i>	<i>R/W</i>	<i>R/W</i>	<i>R/W</i>	<i>R/W</i>	<i>R/W</i>
HCONFIG	DEVADR6	DEVADR5	DEVADR4	DEVADR3	DEVADR2	DEVADR1	DEVADR0

USB hub status registers. Procedure to set the device address:

1. After USB reset, the device responds to default address 0, and hub configuration = 0.
 2. USB host controller issues SET_ADDRESS request to the device. (INTRB asserted)
 3. Micro-controller recognizes the request, then set DEVADR register with appropriate value.
 4. Micro-controller prepares the status stage of SET_ADDRESS request by programming TXCTL0 register.
 5. When the hub configuration value is not equal zero, HCONFIG is set to one.
- USB reset will clear this register.

MODSEL (offset 18, default = 07h)

<i>R/O</i>	<i>R/O</i>	<i>R/O</i>	<i>R/O</i>	<i>R/O</i>	<i>R/O</i>	<i>R/O</i>	<i>R/O</i>
MOD7	MOD6	MOD5	MOD4	MOD3	MOD2	MOD1	MOD0

MOD[7:0] is strapping value at initial state from GPIO[7:0]. GPIO[2:0] is default pull high for keyboard LED control. F/W can utilize these bits for customization.



GL651USB USB KEYBOARD HUB CONTROLLER

6 MAXIMUM RATINGS

Maximum ratings are the extreme limits to which the GL651USB can be exposed without permanently damaging it. The GL651USB contains circuitry to protect the inputs against damage from high static voltages; however, do not apply voltages higher than those shown in the table. Keep V_{IN} and V_{OUT} within the range $GND \leq (V_{IN} \text{ or } V_{OUT}) \leq V_{CC}$. Connect unused inputs to the appropriate voltage level, either GND or V_{DD} .

Symbol	Characteristic	Value	Unit
T _{STG}	Storage temperature	-55 to +150	°C
T _{OP}	Operating temperature	0 to +70	°C
V _{CC}	Supply voltage	-0.5 to +7.0	V
V _{IN}	DC input voltage	-0.5 to +V _{DD} + 0.5	V
I	Maximum current per pin excluding V _{DD} and V _{SS}	25	mA
I _{MGND}	Maximum current out of GND	100	mA
I _{MVCC}	Maximum current out of V _{CC}	100	mA
V _{ESD}	Static discharge voltage	>4000	V

7 ELECTRICAL CHARACTERISTICS

Symbol	Parameter	Test Conditions	Min.	Typ.	Max.	Unit
Supply						
V _{DD}	Digital Power Supply		4.5	5.0	5.5	V
V _{DDA}	Analog Power Supply		4.5	5.0	5.5	V
I _{DD}	Digital Supply Current					mA
I _{DDA}	Analog Supply Current					mA
USB Bus: DP and DM						
V _{CP}	Regulated Voltage Output		3.0	3.3	3.6	V
V _{DI}	Static Input Voltage		0	-	V _{CP}	V
V _{DO}	Static Output Voltage		0	-	V _{CP}	V
Digital I/O Pins						
V _{IL}	Input Logic Low Voltage		-	-	0.8	V
V _{IH}	Input Logic High Voltage		2.0	-	-	V
V _{OL}	Output Logic Low Voltage	I _O =-4.0mA	-	-	0.1xV _{DD}	V
V _{OH}	Output Logic High Voltage	I _O =+4.0mA	0.9xV _{DD}	-	-	V

8. Application Circuit

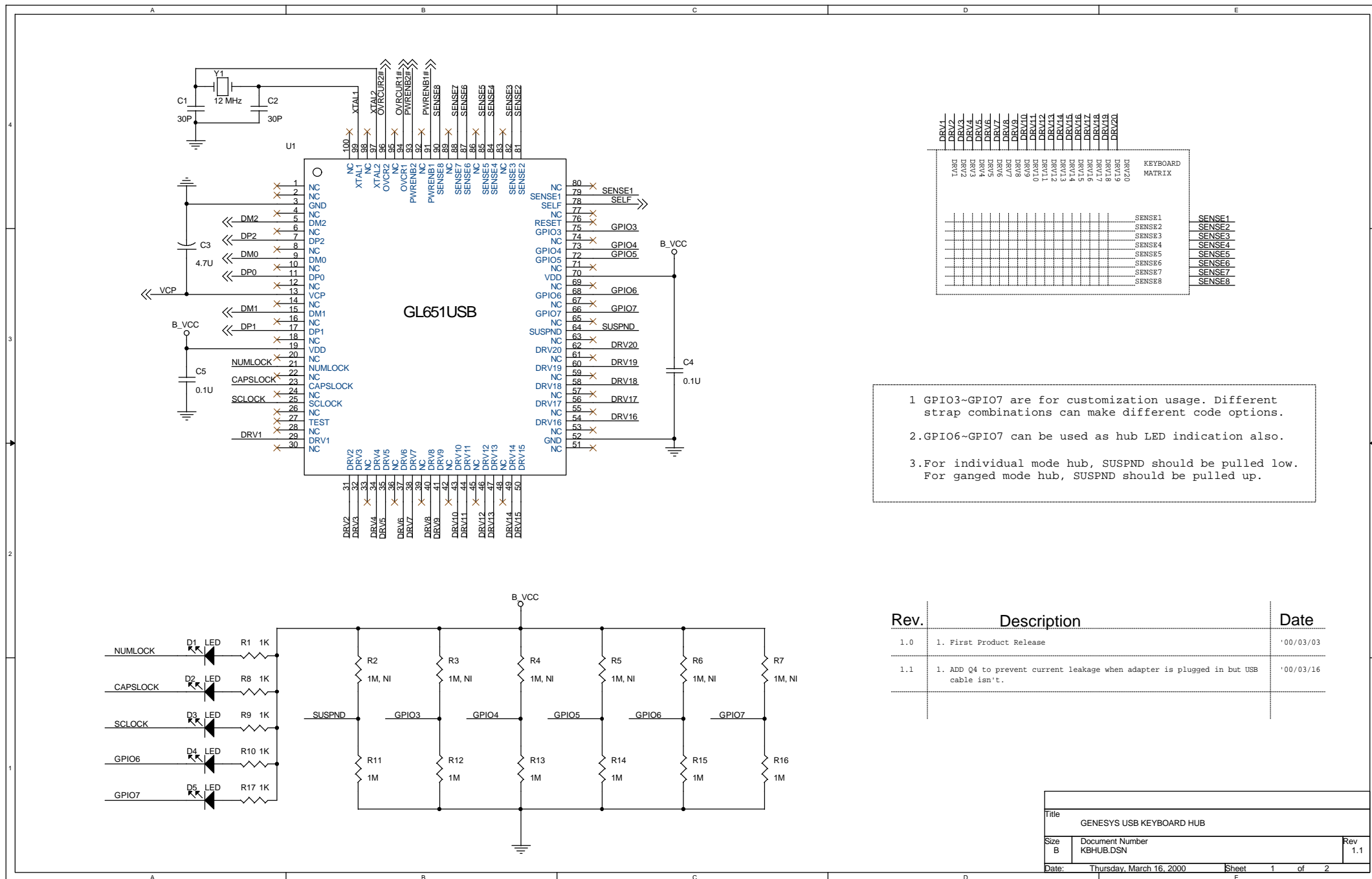

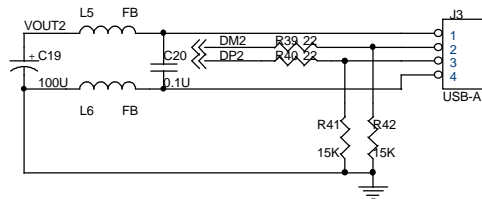
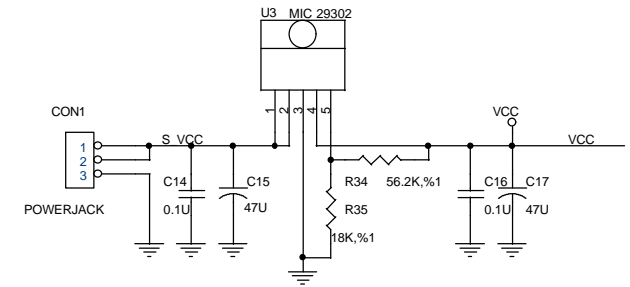
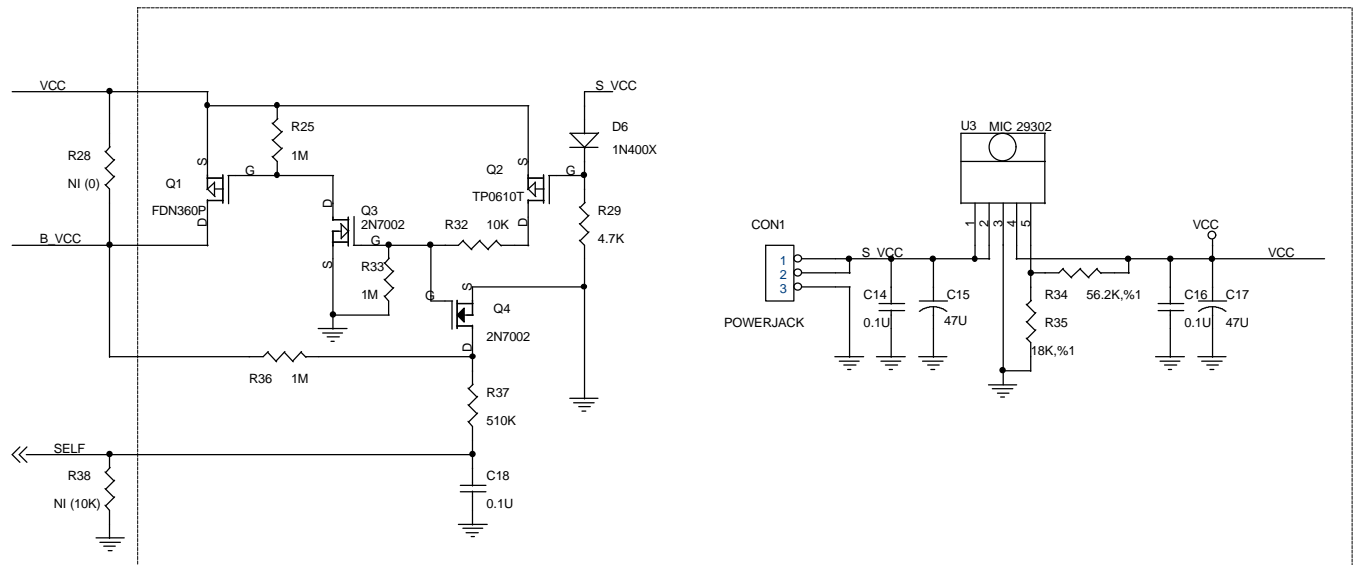
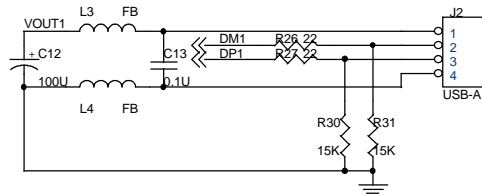
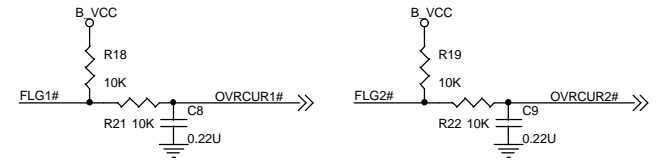
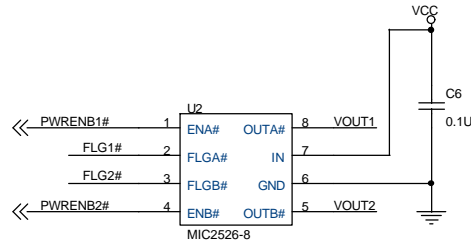
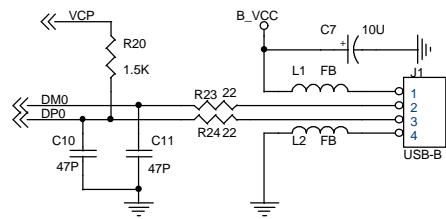

- 1 For pure bus-powered keyboard hub, please DO NOT implement those components in the dotted line, and mount R28 with 0 Ohm and R38 with 10K.
2. For self-bus powered auto-switching keyboard hub, please remove R28, R38 and implement those components in dotted line.

Title		
GENESYS USB KEYBOARD HUB		
Size	Document Number	Rev
B	KBHUB.DSN	1.1
Date:	Thursday, March 16, 2000	Sheet 2 of 2