



Description

The GL7203 is a set-up DC-DC converter that delivers a regulated output current. The device switches at a 1.0MHz constant frequency, allowing for the use of small value external inductor and ceramic capacitors.

The GL7203 is targeted to be used for driving loads up to 1A from a two-cell alkaline battery. The LED current can be programmed by the external current sense resistor, R_s , connected between the feedback pin (FB) and ground. A low 95mV feedback voltage reduces the power loss in the R_s for better efficiency. With its internal 2A, 100mΩ NMOS switch, the device can provide high efficiency even at heavy load. During the shutdown mode, the feedback resistor R_s and the load are completely disconnected and current consumption is reduced to less than 1uA.

Features

- LED Power Efficiency: up to 90%
- Current Accuracy: $\pm 5\%$ ($V_{IN}=3.6$ to $1.8V$ @ $V_F=3.7V$)
- Low Start-Up voltage: 0.9V ($I_{LED}=270mA$)
- Low Hold Voltage: 0.75V ($I_{LED}=200mA$)
- 1MHz Switching Frequency
- Uses small, Low Profile External Components
- Low Start-up Voltage: 0.9V
- Low $R_{DS(ON)}$: 100mΩ(TYP.)
- Open LED Protection
- Over Temperature Protection
- Low Profile SOT-23-6 Package

Application

White LED Torch (Flashlight)

White LED Camera Flash

DSC (Digital Still Camera) Flash

Cellular Camera Phone Flash

PDA Camera Flash

Camcorder Torch (Flashlight) Lamp

Portable Equipment Flash LED

TYPICAL APPLICATIONS

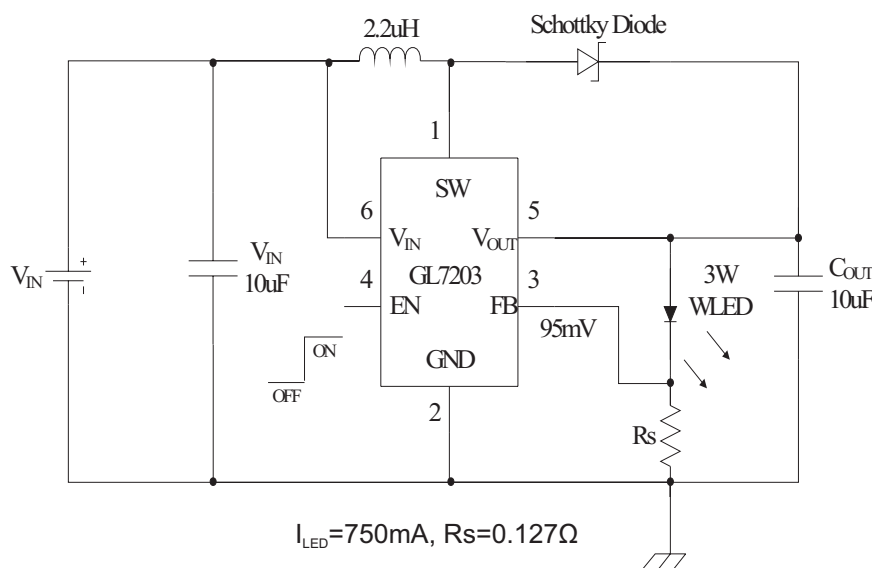

◆ MARKING INFORMATION & PIN CONFIGURATIONS

SOT-26 (SOT-23-6)

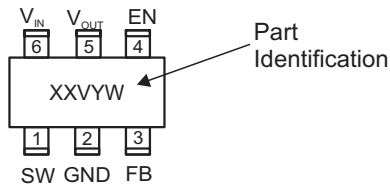

Adjustable Voltage

XX = Marking Code(CD = GL7203)
 V = Voltage Code
 Y = Year
 W = Weekly

◆ ORDERING INFORMATION (Green Package Products are available now!)

Ordering Number	Output Voltage	Package	Shipping
GL7203-ST26R	N / A	SOT-23-6	3000 Units / Reel

* For detail Ordering Number identification, please see last page.

◆ Block Diagram

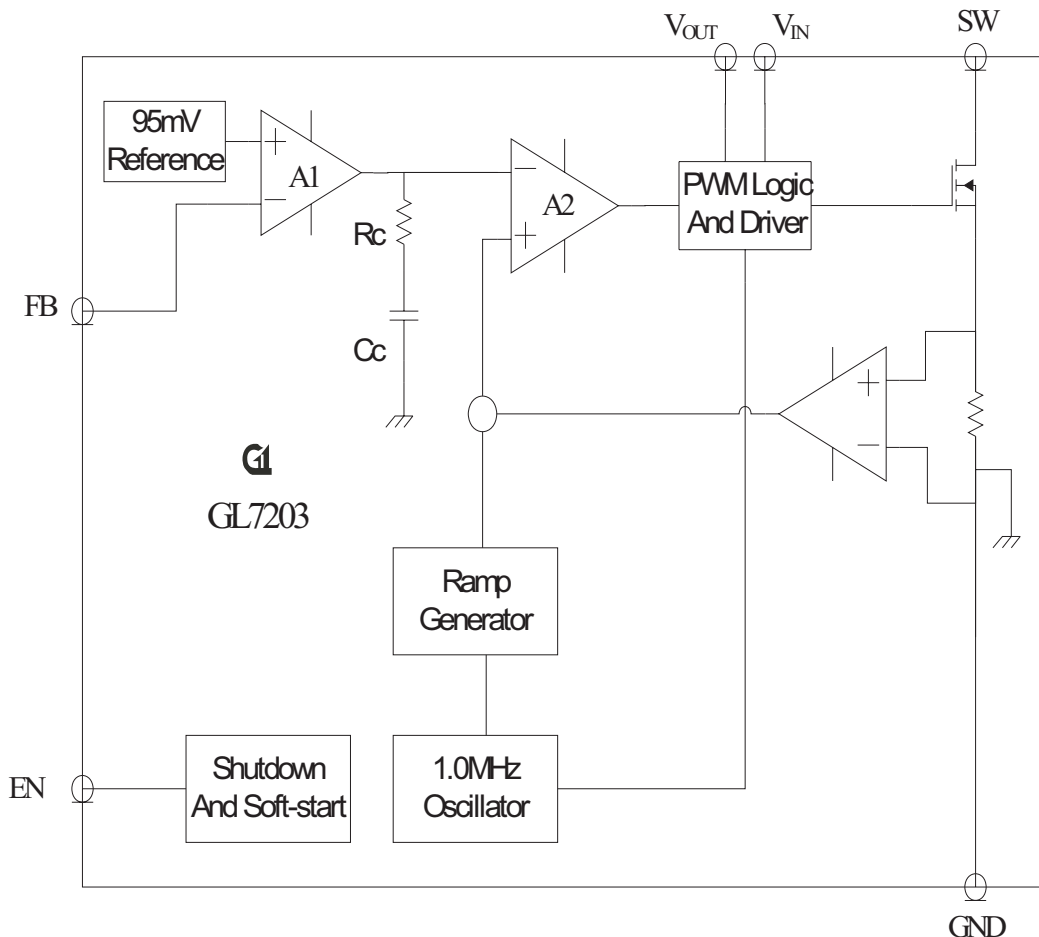



◆ ABSOLUTE MAXIMUM RATINGS

Rating	Value	Unit
Input Pin Voltage	-0.3 ~ 6.0	V
SW Pin Voltage	-0.3 ~ 6.0	V
EN,FB pin Voltage	-0.3 ~ 6.0	V
Maximum Output Current Range	750	mA
Operating Temperature Range	-40 to +85	°C
Storage Temperature Range	-65 to +125	°C
Lead Temperature (Soldering, 5 sec.)	300	°C
Thermal Resistance (Junction to Case)	130	°C/W
Thermal Resistance (Junction to Ambient)	250	°C/W
Internal Power Dissipation (P _D)	400	mW

◆ OPERATING CONDITIONS

Rating	Value	Unit
Ambient Temperature Range	- 40 ~ +85	°C
Junction Temperature Range	- 40 ~ +125	°C

◆ ELECTRICAL CHARACTERISTICS:

T_A=25 °C, V_{IN}=2.4V, I_{LED}=750mA, V_{EN}=V_{IN}, L=2.2uH, C_{IN}=10uF, C_{OUT}=10uF, unless otherwise noted.

Parameter	Conditions	Symbol	Min	Typ	Max	Unit
Input Voltage Range		V _{IN}	0.9	-	V _F -0.2 (Note 1)	V
Feedback Voltage		V _{FB}	90	95	100	mV
Start-Up Voltage	V _{IN} =0 → 3V, I _{LED} =270mA	V _{START}	-	0.9	-	V
Hold Voltage	V _{IN} =3 → 0V, I _{LED} =750→200mA	V _{HOLD}	-	0.75	-	V
Oscillator Frequency		F _{OSC}	0.85	1.0	1.15	MHz
EN Input High	V _{IN} =1.8V	V _{ENH}	1.0	-	-	V
EN Input Low	V _{IN} =1.8V	V _{ENL}	-	-	0.4	V
Over Temperature Shutdown		OTS	-	150	-	°C
Over Temperature Hysteresis		OTH	-	15	-	°C
Quiescent Current	I _{LED} =0mA, V _{OUT} =3.4V, Device Switching at 1MHz	I _Q	-	1	3	mA
Shutdown Current	Shutdown mode	I _{SD}	-	-	1	uA
Switch on Resistance	V _{OUT} =3.4V	R _{DS(ON)}	-	0.1	-	Ω
Current Limit	V _{OUT} =3.4V	I _{LIM}	2	-	-	A
Efficiency	I _{LED} =750mA	η	-	90	-	%

▲ Note 1: V_F-LED forward Voltage



◆ Typical Performance Characteristics

$T_A=25^{\circ}\text{C}$, $L=2.2\mu\text{H}$, $C_{IN}=10\mu\text{F}$, $C_{OUT}=10\mu\text{F}$, unless otherwise noted.

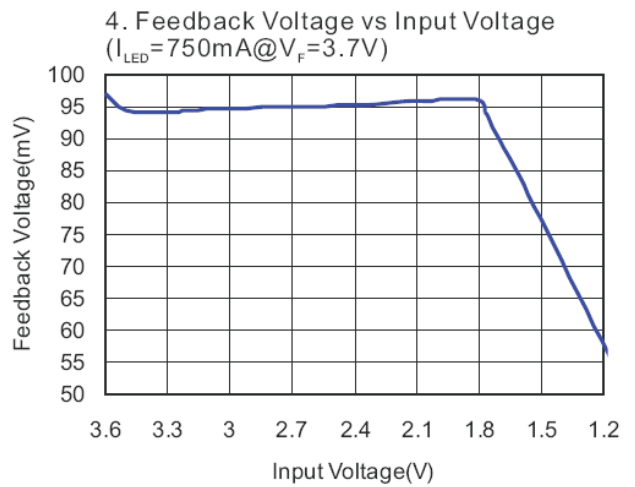
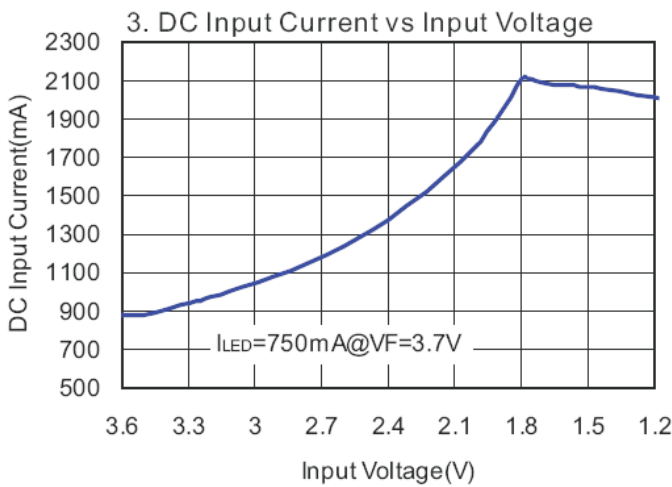
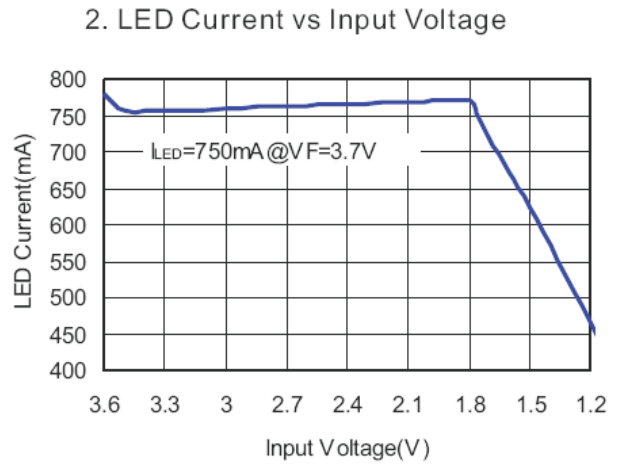
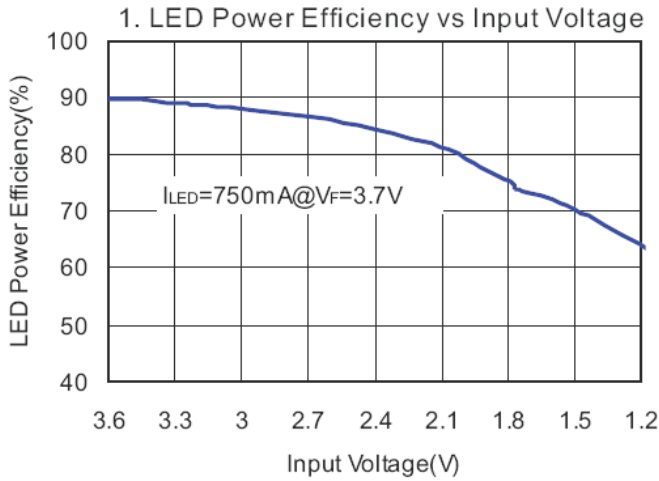



◆ Typical Performance Characteristics

5. Switching Waveform

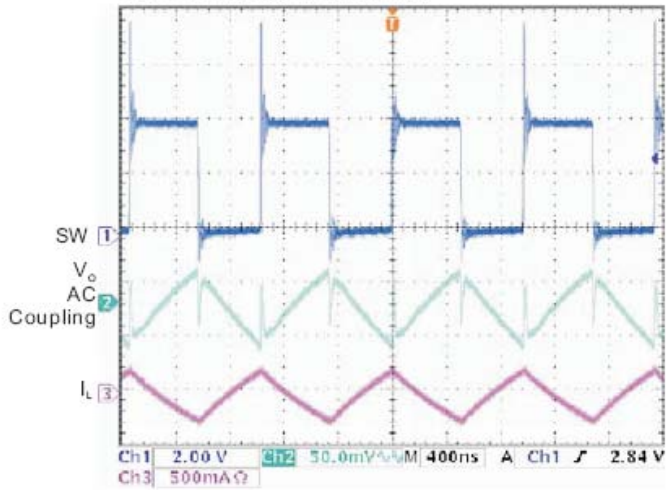

6. Start-Up Waveform

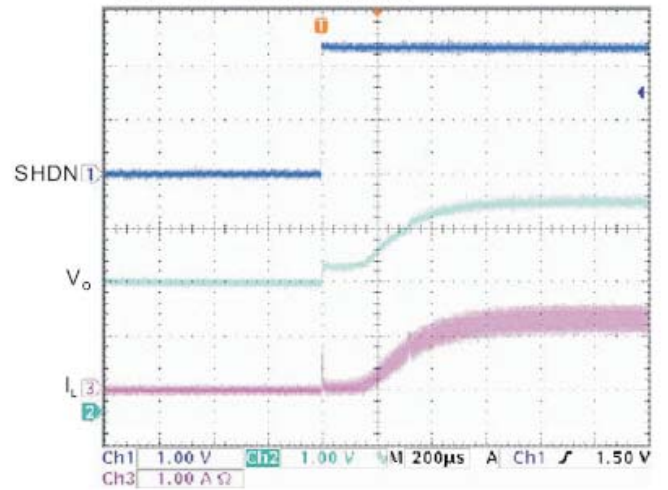

7. Overvoltage Protection

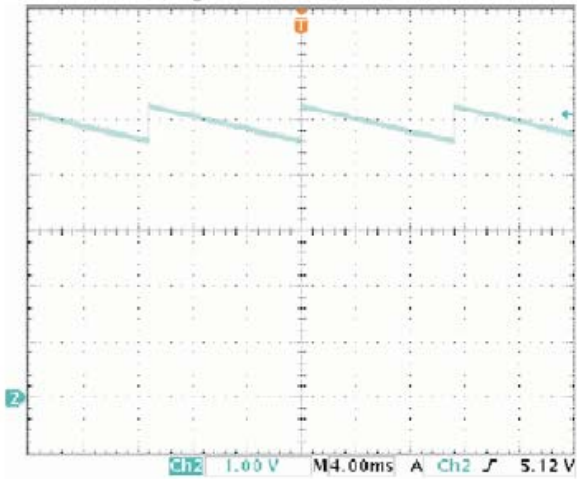



Application Information

Inductor Selection

The GL7203 can use small value inductors due to its switching frequency of 1 MHz. The value of inductor will focus in the range of 2.2uH to 4.7uH for most GL7203 applications. In typical high current white LED applications, it is recommended to use a 4.7uH inductor. The inductor should have low DCR (DC resistance) to minimize the IR power loss, and it requires a current rating of 2A to handle the peak inductor current without saturating.

Capacitor Selection

An input capacitor is required to reduce the input ripple and noise for proper operation of the GL7203. For good input decoupling, Low ESR (equivalent series resistance) capacitors should be used at the input. At least 2.2uF input capacitor is recommended for most applications. A minimum output capacitor value of 6.8uF is recommended under normal operating conditions, while a 10uF-22uF capacitor may be required for higher power LED current. A reasonable value of the output capacitor depends on the LED current. The ESR of the output capacitor is the important parameter to determine the output voltage ripple of the converter, so low ESR capacitors should be used at the output to reduce the output voltage ripple. The small size of ceramic capacitors is an excellent choice for GL7203 applications. The X5R and X7R types are preferred because they maintain capacitance over wide voltage and temperature ranges.

Diode Selection

It's indispensable to use a schottky diode rated at 2A with the GL7203. Using a schottky diode with a lower forward voltage drop is better to improve the power LED efficiency, and its voltage rating should be greater than the output voltage.

LED Current Setting

The LED current is set by the single external Rs resistor connected to the FB pin as shown in the typical application circuit on page 1. The typical FB reference is internally regulated to 95mV. The LED current is 95mV/Rs. It's recommended to use a 1% or better precision resistor for the better LED current accuracy. The formula and table 1 for Rs selection are shown as follows:

$$R_s = \frac{95mV}{I_{LED}}$$

Table 1. Rs Resistor Value Selection

Standard Value (Ω)	I _{LED} (mA)
0.18	528
0.15	633
0.12	792
0.10	950

PCB Layout Guidelines

As for all switching power supplies, the layout and components placement of the GL7203 is an important step in the design; especially at high peak currents and high switching frequencies.

The input capacitor and output capacitor should be placed respectively as close as possible to the input pin and output pin of the IC; the inductor and schottky diode should be placed as close as possible to the switch pin by using wide and short traces for the main current path; the current sense resistor should be placed as close as possible between the ground pin and feedback pin.

◆ SOT-26(SOT-23-6) PACKAGE OUTLINE DIMENSIONS

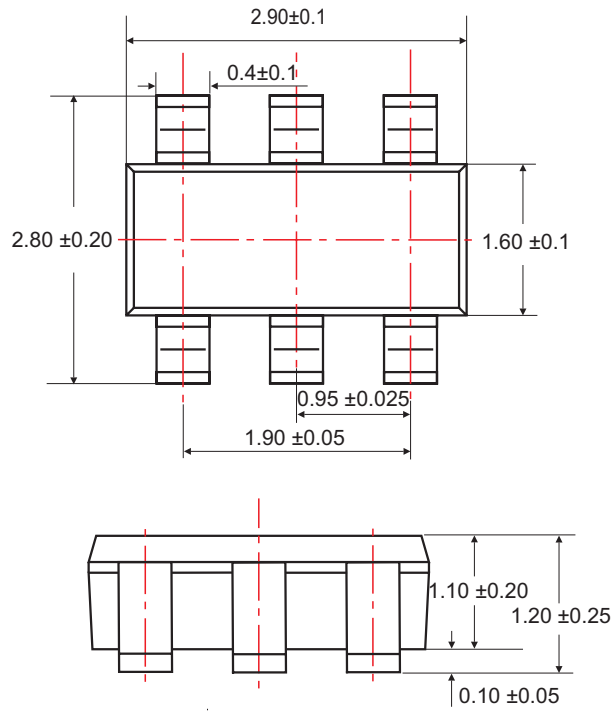

Unit: mm

◆ ORDERING NUMBER

