

FEATURES

- **DynamEQ® II flexibility**
- **five programmable parameters**
- **24 dB/oct state variable filter**
- **twin average detectors**
- **handles high input levels**
- **drives class D integrated receivers**

STANDARD PACKAGING

Hybrid typical dimensions:

0.250 in x 0.115 in x 0.120 in
(6.35 mm x 2.92 mm x 3.05 mm)

DESCRIPTION

The GM3038 programmable hybrid is composed of a DynamEQ® II Wide Dynamic Range Compression signal processor and the ER102 controller memory chip. The hybrid incorporates 24 dB/oct filtering.

The gain and frequency response are dependent on the user's environment. The Twin Average Detector circuit is optimized for sound quality during normal listening without sacrificing comfort during sudden loud sounds.

The GM3038 features five programmable parameters: independent compression ratio adjustment in the High and Low frequency channels, threshold adjustment, crossover frequency adjustment and MPO adjustment.

The ER102 controller memory chip is supported by a variety of programmers available on the market.

The output stage is designed as a preamplifier for the class D integrated receiver.

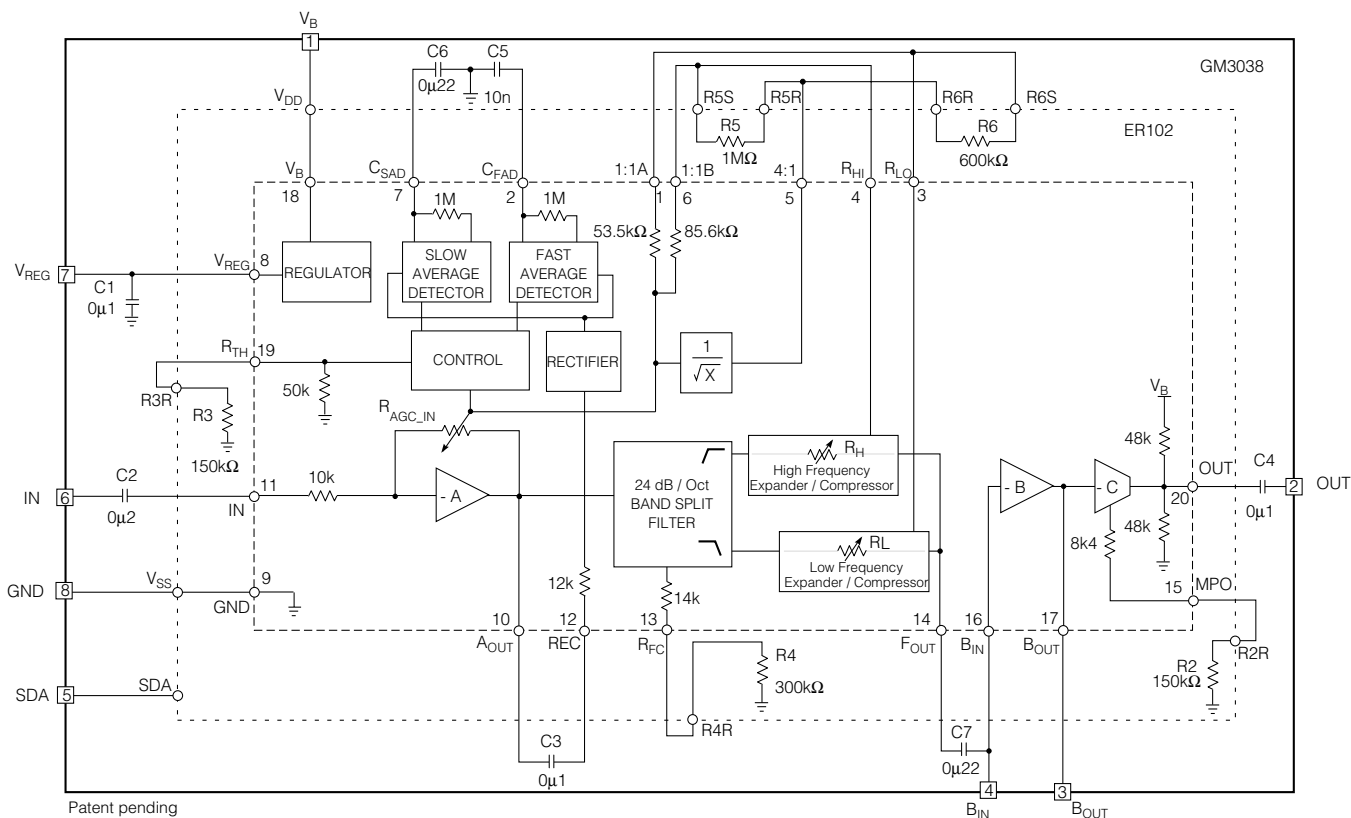
**BLOCK DIAGRAM**

ABSOLUTE MAXIMUM RATINGS

PARAMETER	VALUE / UNITS
Supply Voltage	2VDC
Power Dissipation	25 mW
Operating Temperature Range	-10° C to 40° C
Storage Temperature Range	-20° C to 70° C
Voltage on SDA pad	16V

CAUTION
ELECTROSTATIC
SENSITIVE DEVICES
DO NOT OPEN PACKAGES OR HANDLE
EXCEPT AT A STATIC-FREE WORKSTATION



PAD CONNECTION

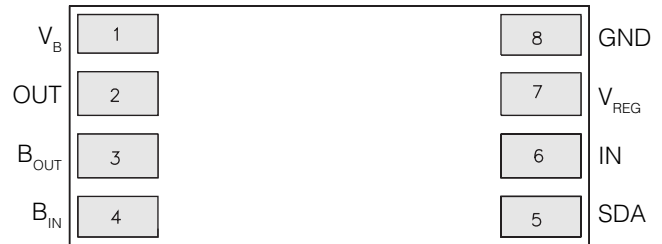

ELECTRICAL CHARACTERISTICS

Refer to ER102 Data Sheet for GM3038 communication and SDA pin Electrical Characteristics

Conditions: Supply Voltage $V_B = 1.3$ V, Frequency = 1 kHz, Temperature = 25°C

The programmable parameters are adjusted to the following set values unless otherwise specified.

(MPO) R2 - set 0; (TH) R3 - set 15; (FC) R4 - set 7; (HP) R5 - set 0; (LP) R6 - set 0

PARAMETER	SYMBOL	CONDITIONS	MIN	TYP	MAX	UNITS
Hybrid Current	I_{AMP}		-	370	530	μ A
Minimum Voltage	Vb		1.1	-	-	V
Total Harmonic Distortion	THD	$V_{IN} = -40$ dBV at 1kHz	-	0.6	1.25	%
THD with Maximum Allowable Input	THD _M	$V_{IN} = -23$ dBV, Rvc = 47k Ω	-	2	10	%
Input Referred Noise	IRN	A Weighted Filter	-	3.0	-	μ V _{RMS}
Total System Gain	A_V	$V_{IN} = -90$ dBV	46	49	52	dB
Regulator Voltage	V_{REG}	$I_{LOAD} = 30$ μ A	890	930	1000	mV
AGC						
Lower Threshold	TH _{LO}		-91	-87	-83	dBV
Upper Threshold	TH _{HI}		-36	-32	-28	dBV
Compression Gain Range	ΔA	Gain(-90dBV _{IN}) -Gain(-30dBV _{IN})	37.5	40.5	43.5	dB
System Gain in Compression	A_{60}	$V_{IN} = -60$ dBV	26	29	32	dB
Min. Compression Ratio	CMP _{1:1}	$V_{IN} = 3$ kHz, -60dBV to -40dBV, R5 - set 31; R6 - set 15	0.9	1.0	1.1	Ratio
Max. Comp. Ratio	CMP _{4:1}	$V_{IN} = 3$ kHz, -60dBV to -40dBV, R5 - set 0; R6 - set 0	3.6	4.0	4.3	Ratio
Fast Detector Time Constant	τ_{FAST}		-	10	-	ms
Slow Detector Time Constant	τ_{SLOW}		-	220	-	ms
FILTER						
Maximum Crossover Frequency	f_{c_0}	R4 - set 0	3.0	3.9	-	kHz
Nominal Crossover Frequency	$f_{c_{22}}$	R4 - set 7	1.38	1.8	2.18	kHz
Minimum Crossover Frequency	$f_{c_{220}}$	R4 - set 13	-	0.9	1.4	kHz
Filter Rolloff Rate			-	24	-	dB/oct

ELECTRICAL CHARACTERISTICS continued

Refer to ER102 Data Sheet for GM3038 communication and SDA pin Electrical Characteristics

Conditions: Supply Voltage $V_B = 1.3\text{ V}$, Frequency = 1 kHz, Temperature = 25°C

The programmable parameters are adjusted to the following set values unless otherwise specified. (MPO) R2 - set 0; (TH) R3 - set 15;

(FC) R4 - set 7; (HP) R5 - set 0; (LP) R6 - set 0

PARAMETER	SYMBOL	CONDITIONS	MIN	TYP	MAX	UNITS
STAGE A and B						
Open Loop Gain (B)	A_{OLB}		-	52	-	dB
Input Impedance (A)	R_{IN}		9	11	13	k Ω
OUTPUT STAGE						
Stage Gain	A_C	$V_{IN} = -30\text{dBV}$	7	9	11	dB
Max Output Level	MPO	$R_{VC} = 220\text{k}\Omega, V_{IN} = -25\text{dBV}$	-14.5	-12.5	-10.5	dBV
MPO Range	ΔMPO	R2 - set 0 to set 11	13	15	17	dB
Output Resistance	R_{OUT}		-	24	-	k Ω

All conditions and parameters remain as shown in the Test Circuit unless otherwise specified in the CONDITIONS column.

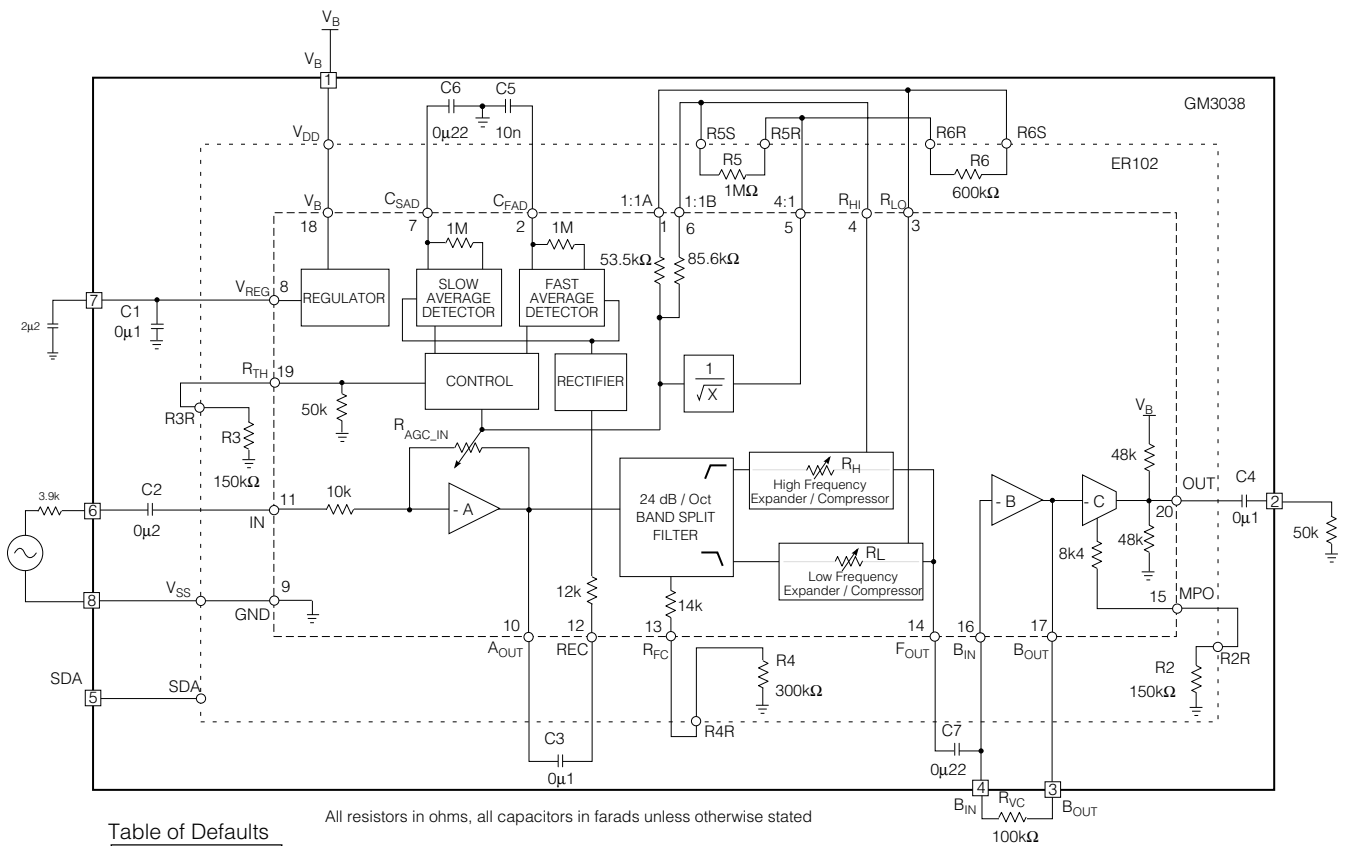

Table of Defaults

R2 - set 0
R3 - set 15
R4 - set 7
R5 - set 0
R6 - set 0

Fig. 1 Production Test Circuit

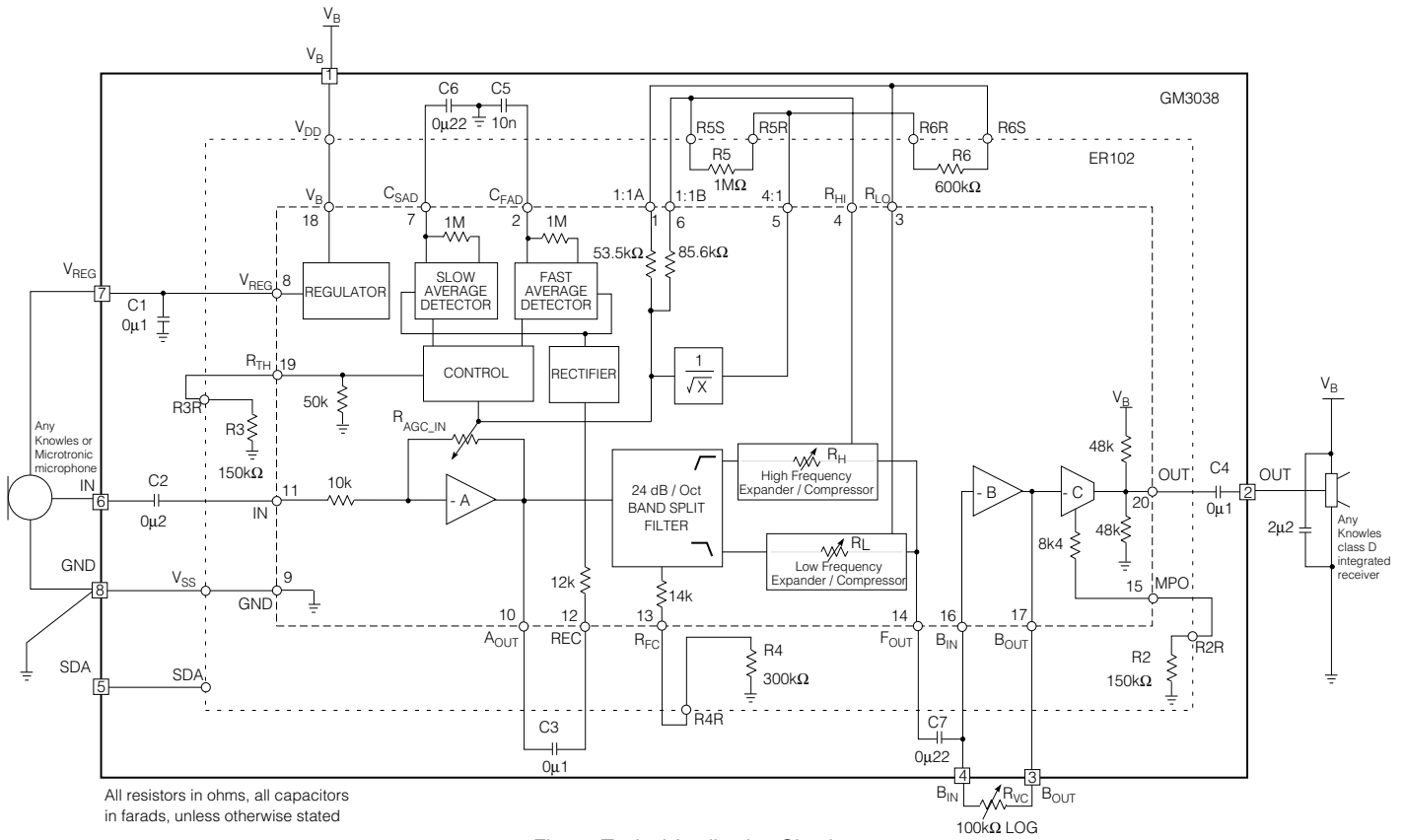

Fig. 2 Typical Application Circuit

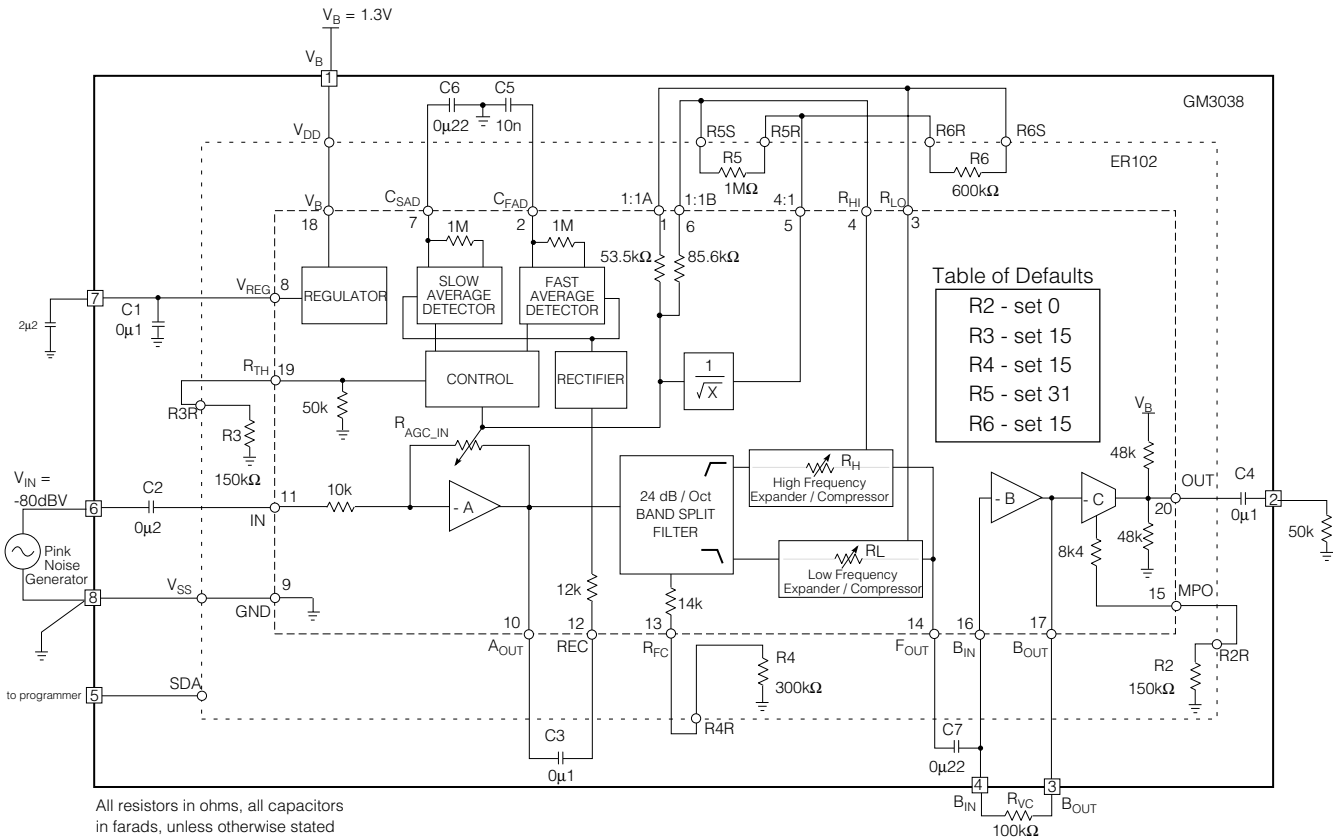

Fig. 3 Characterization Circuit (Used to generate typical curves)

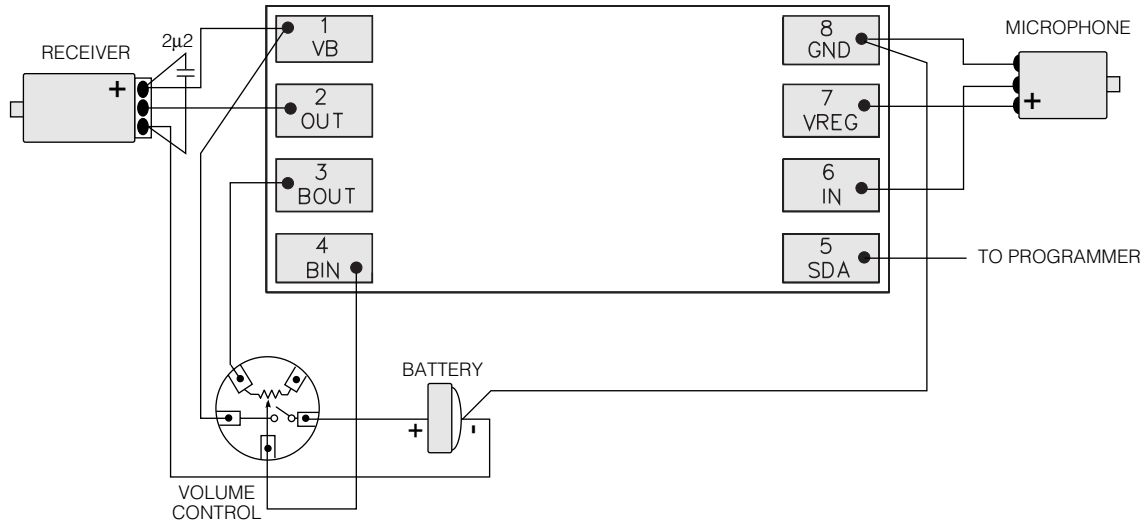

Fig. 4 Typical Assembly Diagram

TYPICAL PERFORMANCE CURVES

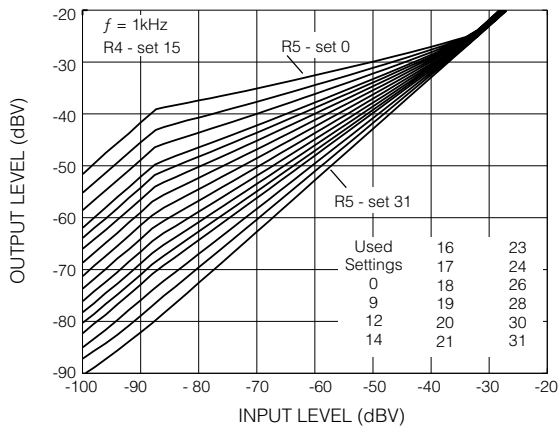

Fig. 5 I/O Transfer Function for Different Compression Ratios (High Frequency Channel)



Fig. 6 High Frequency Gain (Compression Ratio Adjustment)

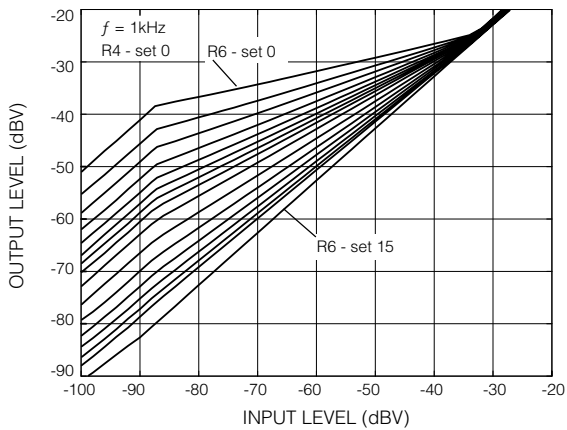

Fig. 7 I/O Transfer Function for Different Compression Ratios (Low Frequency Channel)

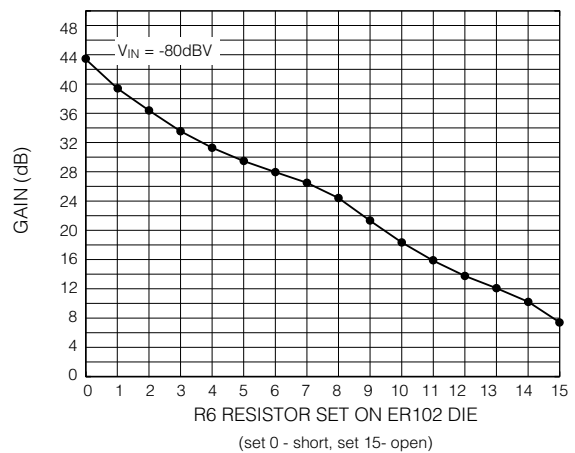

Fig. 8 Low Frequency Gain (Compression Ratio Adjustment)

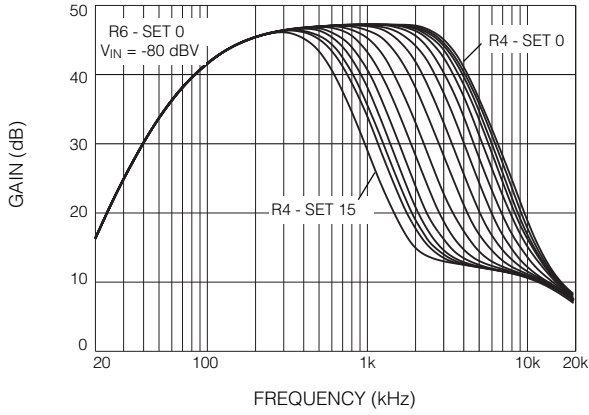

Fig. 9 Frequency Response for Different Crossover Frequency Steps

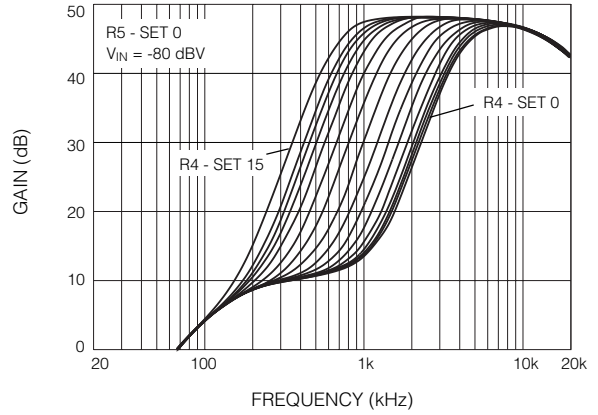

Fig. 10 Frequency Response for Different Crossover Frequency Steps

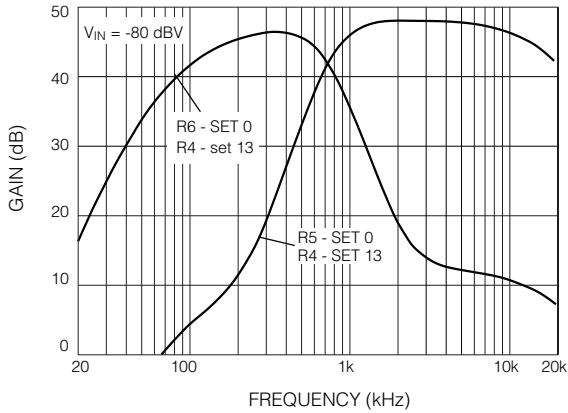

Fig. 11 Crossover Frequency Representation for Step 13

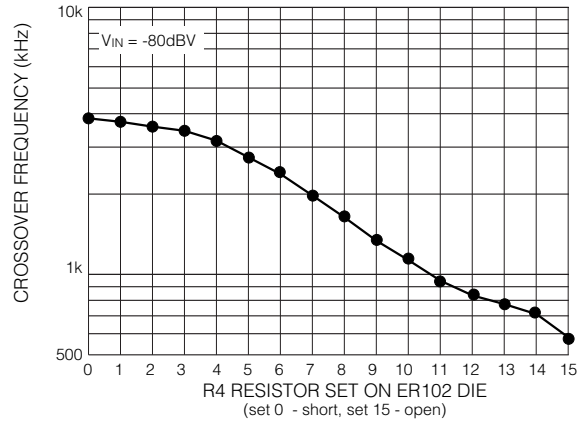

Fig. 12 Crossover Frequency Adjustment

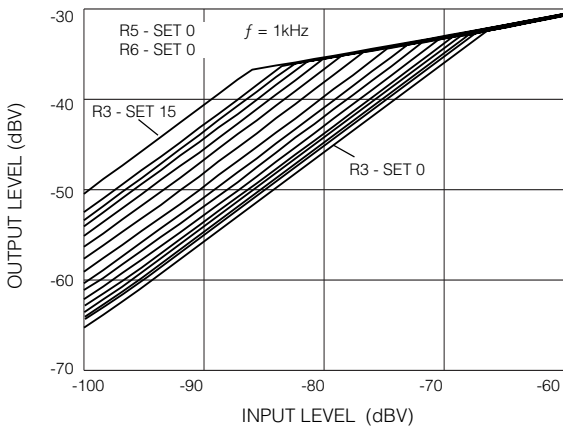

Fig. 13 I/O Transfer Function for Different Threshold Steps

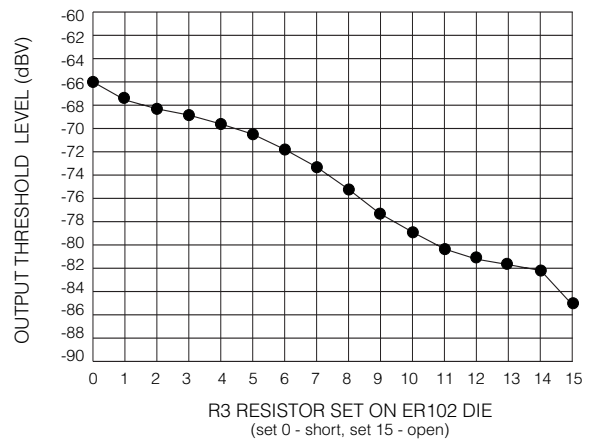

Fig. 14 Threshold Adjustment

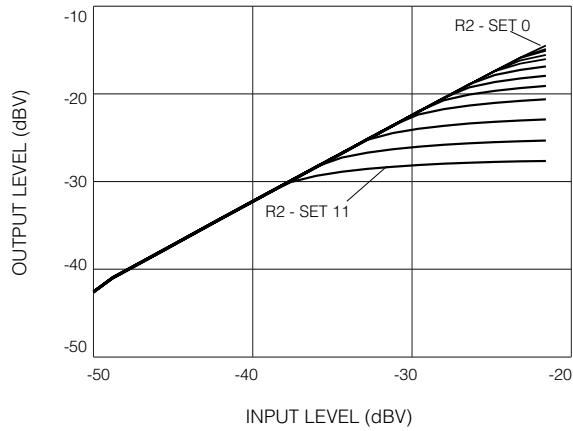

Fig. 15 I/O Transfer Function for Different MPO Steps

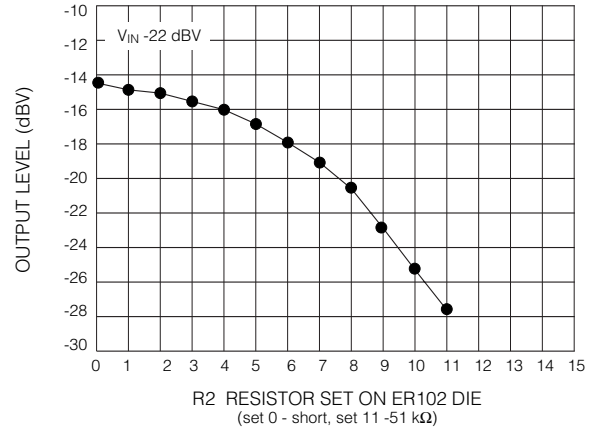

Fig. 16 MPO Adjustment

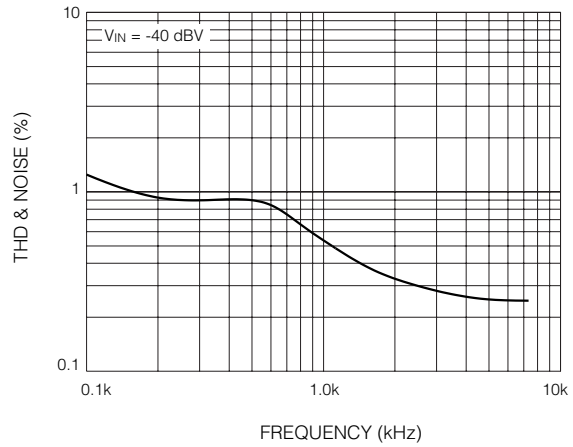

Fig. 17 THD and Noise vs Frequency

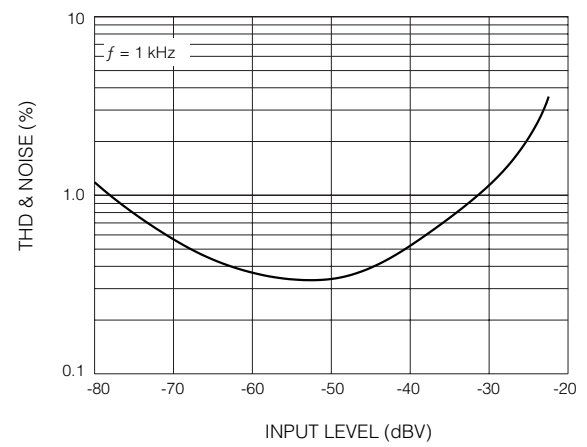

Fig. 18 THD and Noise vs Input Level

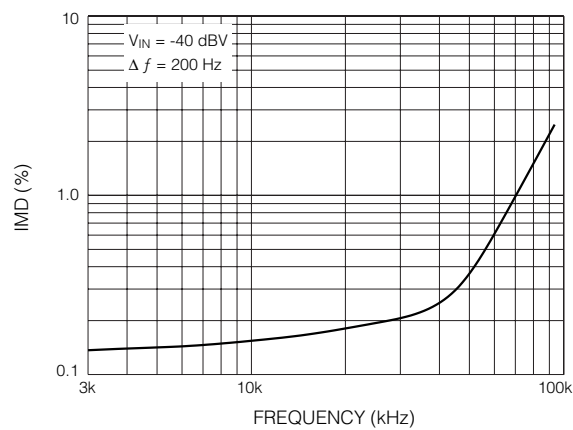

Fig. 19 Intermodulation Distortion (CCIF) vs Frequency

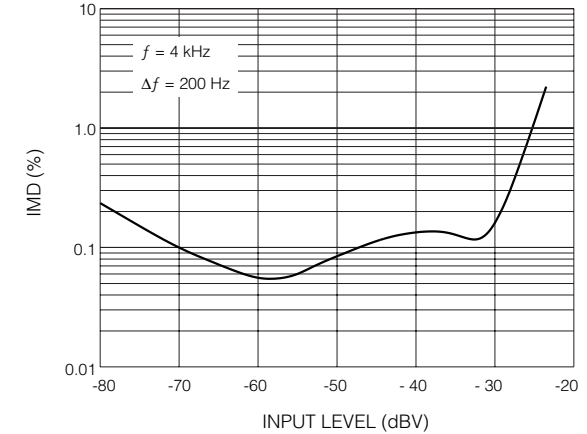

Fig. 20 Intermodulation Distortion (CCIF) vs Input Level

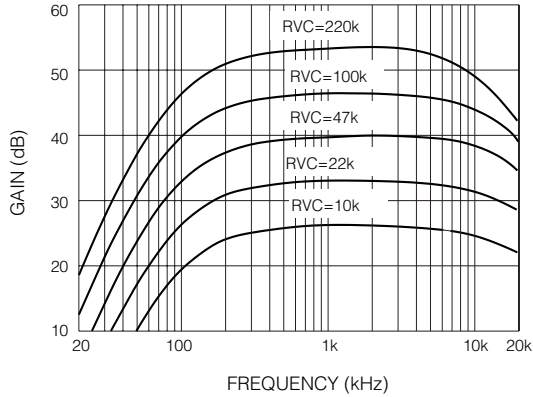
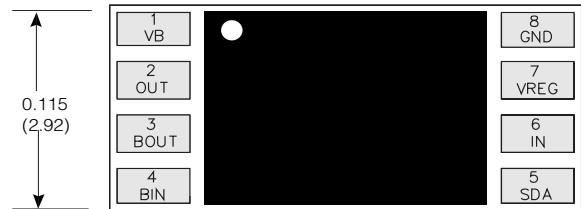
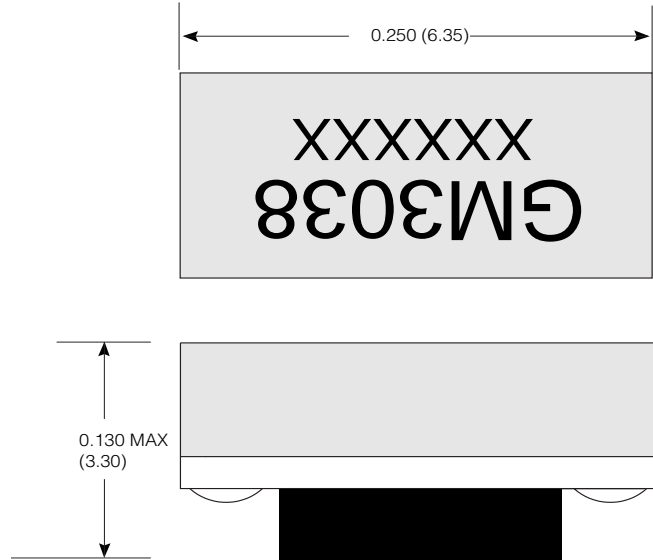

Fig. 21 Frequency Response for Different R_{VC} Values

PACKAGE DIMENSIONS



Dimensions are in inches.
 Dimensions in parenthesis are in millimetres converted from inches and include minor rounding errors.
 1.0000 inches = 25.400 mm.
 Dimension tolerances ± 0.003 (± 0.08) unless otherwise stated.
 XXXXXX - work order number.
 This hybrid is designed for point-to-point manual soldering.

GENNUM CORPORATION
 MAILING ADDRESS:
 P.O. Box 489, Stn. A, Burlington, Ontario, Canada L7R 3Y3
 Tel. +1 (905) 632-2996 Fax +1 (905) 632-2814
 SHIPPING ADDRESS:
 970 Fraser Drive, Burlington, Ontario, Canada L7L 5P5
 GENNUM JAPAN CORPORATION
 C-101, Miyamae Village, 2-10-42 Miyamae, Suginami-ku, Tokyo 168-0081,
 Japan Tel. +81 (3) 3334-7700 Fax: +81 (3) 3247-8839

DOCUMENT IDENTIFICATION:
 DATA SHEET
 The product is in production. Gennum reserves the right to make changes at any time to improve reliability, function or design, in order to provide the best product possible.

REVISION NOTES:
 Added maximum voltage on SDA pad.
 Change to max. supply voltage.