



GM338/GM398 Mobile Radios

Basic Service Manual

6804112J17-D

Computer Software Copyrights

The Motorola products described in this manual may include copyrighted Motorola computer programs stored in semiconductor memories or other media. Laws in the United States and other countries preserve for Motorola certain exclusive rights for copyrighted computer programs, including the exclusive right to copy or reproduce in any form, the copyrighted computer program. Accordingly, any copyrighted Motorola computer programs contained in the Motorola products described in this manual may not be copied or reproduced in any manner without the express written permission of Motorola. Furthermore, the purchase of Motorola products shall not be deemed to grant, either directly or by implication, estoppel or otherwise, any license under the copyrights, patents or patent applications of Motorola, except for the normal non-exclusive royalty-free license to use that arises by operation of law in the sale of a product.

SAFETY INFORMATION

SAFETY AND GENERAL INFORMATION

Information and Instructions on RF Energy Exposure and Product Safety

READ THIS IMPORTANT INFORMATION ON SAFE AND EFFICIENT OPERATION BEFORE INSTALLING AND USING YOUR MOTOROLA MOBILE TWO-WAY RADIO IN A VEHICLE OR AS A CONTROL STATION.

Compliance with RF Energy Exposure Standards

Your Motorola two-way radio is designed and tested to comply with a number of national and international standards and guidelines (listed below) regarding human exposure to radio frequency electromagnetic energy. This radio complies with the IEEE (FCC) and ICNIRP exposure limits at duty cycles of up to 50% talk-50% listen and should be used for occupational use only. In terms of measuring RF energy for compliance with the FCC exposure guidelines, your radio radiates measurable RF energy only while it is transmitting (during talking), not when it is receiving (listening) or in standby mode.

Your Motorola two-way radio complies with the following RF energy exposure standards and guidelines:

- United States Federal Communications Commission, Code of Federal Regulations; 47CFR part 2 sub-part J
- American National Standards Institute (ANSI) / Institute of Electrical and Electronic Engineers (IEEE) C95. 1-1992
- Institute of Electrical and Electronic Engineers (IEEE) C95.1-1999 Edition
- International Commission on Non-Ionizing Radiation Protection (ICNIRP) 1998
- Ministry of Health (Canada) Safety Code 6. Limits of Human Exposure to Radio frequency Electromagnetic Fields in the Frequency Range from 3 kHz to 300 GHz, 1999
- Australian Communications Authority Radiocommunications (Electromagnetic Radiation - Human Exposure) Standard 2001
- ANATEL, Brazil Regulatory Authority, Resolution 256 (April 11, 2001) "additional requirements for SMR, cellular and PCS product certification."

Operational Instructions and Training Guidelines

To ensure optimal performance and compliance with the RF energy exposure limits in the above standards and guidelines, users should transmit no more than 50% of the time and always adhere to the following procedures:

Transmit and Receive

- To transmit (talk), push the Push-To-Talk (PTT) button; to receive, release the PTT button.
- Transmit only when people outside the vehicle are at least the minimum lateral distance away, as shown in Table 1, from a properly installed, externally-mounted antenna.

Table 1 lists the minimum lateral distance for bystanders in an uncontrolled environment from the transmitting antenna at several different ranges of rated radio power for mobile radios installed in a vehicle.

Table 1: Rated Power and Lateral Distance

Rated Power of Vehicle-Installed Mobile Two-way Radio	Minimum Lateral Distance from Transmitting Antenna
Less than 7 watts	8 inches (20 centimeters)
7 to 15 watts	1 foot (30 centimeters)
16 to 50 watts	2 feet (60 centimeters)
51 to 110 watts	3 feet (90 centimeters)

Mobile Antennas

- Install antennas at the center of the roof or the center of the trunk deck. These mobile antenna installation guidelines are limited to metal body vehicles.
- The antenna installation must additionally be in accordance with:
 - a. The requirements of the antenna manufacturer/supplier
 - b. Instructions in the Radio Installation Manual
- **Use only Motorola approved supplied antenna or Motorola approved replacement antenna.** Unauthorized antennas, modifications, or attachments could damage the radio and may violate FCC regulations.

Approved Accessories

For a list of approved Motorola accessories please contact your dealer, or local Motorola representative.

Fixed Site Antennas

If mobile radio equipment is installed at a fixed location and operated as a control station or as a fixed unit, the antenna installation must comply with the following requirements in order to ensure optimal performance and compliance with the RF energy exposure limits in the above standards and guidelines.

- The antenna should be mounted outside the building on the roof or a tower if at all possible.
- As with all fixed site antenna installations, it is the responsibility of the licensee to manage the site in accordance with applicable regulatory requirements and may require additional compliance actions such as site survey measurements, signage, and site access restrictions in order to insure that exposure limits are not exceeded.

ELECTROMAGNETIC INTERFERENCE/COMPATIBILITY

NOTE Nearly every electronic device is susceptible to electromagnetic interference (EMI) if inadequately shielded, designed, or otherwise configured for electromagnetic compatibility. It may be necessary to conduct compatibility testing to determine if any electronic equipment used in or around vehicles or near fixed antenna sites is sensitive to external RF energy and if any procedures need to be followed to eliminate or mitigate the potential for interaction between the radio transmitter and the equipment or device.

Facilities

To avoid electromagnetic interference and/or compatibility conflicts, turn off your radio in any facility where posted notices instruct you to do so. Hospitals or health care facilities may be using equipment that is sensitive to external RF energy.

Vehicles

To avoid possible interaction between the radio transmitter and any vehicle electronic control modules, for example, ABS, engine, or transmission controls, we recommend that the radio be installed by an experienced installer and that the following precautions be used when installing the radio:

1. Refer to any manufacturer's instructions or other technical bulletins or recommendations on radio installation.
2. Before installing the radio, determine the location of the electronic control modules and their harnesses in the vehicle.
3. Route all radio wiring, including the antenna transmission line, as far away as possible from the electronic control units and associated wiring.

Driver Safety

Check the laws and regulations on the use of radios in the area where you drive. Always obey them.

When using your radio while driving, please:

- Give full attention to driving and to the road.
- Pull off the road and park before making or answering a call if driving conditions so require.

OPERATIONAL WARNINGS

For Vehicles With an Air Bag

Do not place a mobile radio in the area over an air bag or in the air bag deployment area. Air bags inflate with great force. If a radio is placed in the air bag deployment area and the air bag inflates, the radio may be propelled with great force and cause serious injury to occupants of the vehicle.



Potentially Explosive Atmospheres

Turn off your radio prior to entering any area with a potentially explosive atmosphere. Sparks in a potentially explosive atmosphere can cause an explosion or fire resulting in bodily injury or even death.

NOTE The areas with potentially explosive atmospheres referred to above include fueling areas such as below decks on boats, fuel or chemical transfer or storage facilities, and areas where the air contains chemicals or particles, such as grain, dust or metal powders. Areas with potentially explosive atmospheres are often but not always posted.

Blasting Caps and Areas

To avoid possible interference with blasting operations, turn off your radio when you are near electrical blasting caps, in a blasting area, or in areas posted: "Turn off two-way radio." Obey all signs and instructions.

For radios installed in vehicles fuelled by liquefied petroleum gas in the U.S., refer to the (U.S.) National Fire Protection Association standard, NFPA 58, for storage, handling, and/or container information. For a copy of the LP-gas standard, NFPA 58, contact the National Fire Protection Association, One Battery Park, Quincy, MA.

THIS PAGE INTENTIONALLY LEFT BLANK

Table of Contents

Section 1 Introduction

1.0	Scope of Manual	1-1
2.0	Warranty and Service Support.....	1-1
2.1	Warranty Period and Return Instructions	1-1
2.2	After Warranty Period	1-1
2.3	Piece Parts Availability	1-2
2.4	Technical Support.....	1-2
3.0	Radio Model Information.....	1-3

Section 2 Maintenance

1.0	Introduction	2-1
2.0	Preventive Maintenance	2-1
2.1	Inspection	2-1
2.2	Cleaning Procedures	2-1
3.0	Safe Handling of CMOS and LDMOS Devices	2-2
4.0	Repair Procedures and Techniques — General	2-3
5.0	Disassembling and Reassembling the Radio — General	2-3
6.0	Radio Disassembly - Detailed.....	2-4
6.1	Control Head Removal	2-4
6.2	Top Cover Removal.....	2-5
6.3	Transceiver Board Removal	2-6
6.4	Disassembly of Control Heads	2-7
7.0	Radio Assembly	2-9
7.1	Control Heads - GM338 and GM398.....	2-9
7.2	Radio Chassis And Transceiver Board.....	2-9
7.3	Control Head Fitting.....	2-9
8.0	Radio Exploded Mechanical Views and Parts Lists	2-10
8.1	Radio Assembly.....	2-10
8.2	Control Head - GM338	2-11
8.3	Control Head - GM398	2-12
9.0	Service Aids	2-13
10.0	Test Equipment.....	2-14
11.0	Programming/Test Cable - RKN4083_	2-15

Section 3 Transceiver Performance Testing

1.0	General	3-1
2.0	Setup.....	3-1
3.0	RF Test Mode	3-2

Section 4 Radio Tuning and Programming

1.0 Introduction	4-1
2.0 CPS Programming Setup	4-1
3.0 Radio Tuning Setup	4-3
3.1 Initial Test Equipment Control Settings	4-3

Section 5 Power Up Self-Test

1.0 Error Codes	5-1
-----------------------	-----

Section 6 Model Chart and Test Specification

1.0 Low Power Radios	6-1
1.1 Model Chart (VHF 136-174 MHz)	6-1
1.2 Model Chart (UHF Band 1, 403-470 MHz)	6-2
1.3 Model Chart (UHF Band 2, 450-527 MHz)	6-3
1.4 Model Chart (Low Band, 29.7-50.0 MHz)	6-3
1.5 Specifications	6-4
2.0 High Power Radios	6-6
2.1 Model Chart (VHF 136-174 MHz)	6-6
2.2 Model Chart (UHF Band 1, 403-470 MHz)	6-6
2.3 Model Chart (UHF Band 2, 450-520 MHz)	6-7
2.4 Model Chart (UHF Band 1, LDMOS, 403-470 MHz)	6-7
2.5 Model Chart (UHF Band 2, LDMOS, 450-520 MHz)	6-8
2.6 Specifications	6-9

Glossary of Terms	G-1
--------------------------------	------------

Section 1

INTRODUCTION

1.0 Scope of Manual

This manual is intended for use by service technicians familiar with similar types of equipment. It contains service information required for the equipment described and is current as of the printing date. Changes which occur after the printing date may be incorporated by a complete manual revision or alternatively as additions.

NOTE Before operating or testing these units, please read the Safety Information section in the front of this manual.

2.0 Warranty and Service Support

Motorola offers support which includes: full exchange and/or repair of the product during the warranty period; and service/ repair or spare parts support out of warranty. Any “return for exchange” or “return for repair” to an authorized Motorola Dealer must be accompanied by a Warranty Claim Form. Warranty Claim Forms are obtained by contacting an Authorized Motorola Dealer.

2.1 Warranty Period and Return Instructions

The terms and conditions of warranty are defined fully in the Motorola Dealer or Distributor or Reseller contract. These conditions may change from time to time, and the following subsections are for guidance purposes only.

In instances where the product is covered under a “return for replacement” or “return for repair” warranty, a check of the product should be performed prior to shipping the unit back to Motorola. This is to ensure that the product has been correctly programmed or has not been subjected to damage outside the terms of the warranty.

Prior to shipping any radio back to the appropriate Motorola warranty depot, please contact Customer Resources. All returns must be accompanied by a Warranty Claim Form, available from your Customer Resources representative. Products should be shipped back in the original packaging, or correctly packaged to ensure that no damage occurs in transit.

2.2 After Warranty Period

After the Warranty period, Motorola continues to support its products in two ways:

1. Motorola's Accessories and Aftermarket Division (AAD) offers a repair service to both end users and dealers at competitive prices.
2. AAD supplies individual parts and modules that can be purchased by dealers who are technically capable of performing fault analysis and repair.

2.3 Piece Parts Availability

Some replacement parts, spare parts, and/or product information can be ordered directly. If a complete Motorola part number is assigned to the part, it is available from Motorola's Accessories and Aftermarket Division (AAD). If no part number is assigned, the part is not normally available from Motorola. If the part number is appended with an asterisk, the part is serviceable by Motorola Depot only. If a parts list is not included, this generally means that no user-serviceable parts are available for that kit or assembly.

All orders for parts/information should include the complete Motorola identification number. All part orders should be directed to your local AAD office. Please refer to your latest price pages.

2.4 Technical Support

Technical support is available to assist the dealer/distributor in resolving any malfunction which may be encountered. Initial contact should be by telephone wherever possible. When contacting Motorola Technical Support, be prepared to provide the product **model number** and the unit's **serial number**.

Toll-Free

Country or Territory	Number
China	800-810-0976
Indonesia	0800-1-686868
Malaysia	1800-801687
Philippines	1800-16510271
Singapore	1800-4855333
Thailand	1800-225412

Non-Toll-Free

Country or Territory	Number
China	(86-10) 6843-8231
Hong Kong SAR	(852) 2966-4188
India	(91) 80-658-7677-7678
Indonesia	(62-21) 251-3050
Korea	(822) 3466-5401
Malaysia	(603) 7803-9922
Philippines	(63-2) 810-0762
Singapore	(65) 486-7171
Taiwan	(886) 2-27058000 ext. 6308
Thailand	(66) 2254-8388
Vietnam	(84) 8-8294091
All Other Countries	IDD code + (65) 4855333

3.0 Radio Model Information

The model number and serial number are located on a label attached to the back of your radio. You can determine the RF output power, frequency band, protocols, and physical packages. The example below shows one mobile radio model number and its specific characteristics.

Table 1-1 Radio Model Number (**Example:** AZM25KHF9AA5)

	Type of Unit	Model Series	Freq. Band	Power Level	Physical Packages	Channel Spacing	Protocol	Feature Level
AZ = Country Code	M ↑ M = Mobile	25	K VHF (136-174MHz)	H 1-25W	F GM338	9 Program- mable	AA Conventional	5 GM338
			R UHF1 (403-470MHz)	K 25-60W	N GM398			8 GM398
			S UHF2 (450-527MHz)					
			B LB, R1 (29.7-36MHz)					
			C LB, R2 (36-40MHz)					
			D LB, R3 (42-50MHz)					

THIS PAGE INTENTIONALLY LEFT BLANK

Section 2

MAINTENANCE

1.0 Introduction

This chapter provides details about the following:

- Preventive maintenance (inspection and cleaning).
- Safe handling of CMOS and LDMOS devices.
- Disassembly and reassembly of the radio.
- Repair procedures and techniques.

2.0 Preventive Maintenance

The radios do not require a scheduled preventive maintenance program; however, periodic visual inspection and cleaning is recommended.

2.1 Inspection

Check that the external surfaces of the radio are clean, and that all external controls and switches are functional. It is not recommended to inspect the interior electronic circuitry.

2.2 Cleaning Procedures

The following procedures describe the recommended cleaning agents and the methods to be used when cleaning the external and internal surfaces of the radio. External surfaces include the front cover, housing assembly and battery case. These surfaces should be cleaned whenever a periodic visual inspection reveals the presence of smudges, grease, and/or grime.

NOTE Internal surfaces should be cleaned only when the radio is disassembled for service or repair.

The only recommended agent for cleaning the external radio surfaces is a 0.5% solution of a mild dishwashing detergent in water. The only factory recommended liquid for cleaning the printed circuit boards and their components is isopropyl alcohol (70% by volume).



CAUTION: The effects of certain chemicals and their vapors can have harmful results on certain plastics. Avoid using aerosol sprays, tuner cleaners, and other chemicals.

Cleaning External Plastic Surfaces

Apply the 0.5% detergent-water solution sparingly with a stiff, non-metallic, short-bristled brush to work all loose dirt away from the radio. Use a soft, absorbent, lintless cloth or tissue to remove the solution and dry the radio. Make sure that no water remains entrapped near the connectors, cracks, or crevices.

Cleaning Internal Circuit Boards and Components

Isopropyl alcohol (70%) may be applied with a stiff, non-metallic, short-bristled brush to dislodge embedded or caked materials located in hard-to-reach areas. The brush stroke should direct the dislodged material out and away from the inside of the radio. Make sure that controls or tunable components are not soaked with alcohol. Do not use high-pressure air to hasten the drying process since this could cause the liquid to collect in unwanted places. After completing of the cleaning process, use a soft, absorbent, lintless cloth to dry the area. Do not brush or apply any isopropyl alcohol to the frame, front cover, or back cover.

NOTE Always use a fresh supply of alcohol and a clean container to prevent contamination by dissolved material (from previous usage).

3.0 Safe Handling of CMOS and LDMOS Devices

Complementary metal-oxide semiconductor (CMOS) devices are used in this family of radios, and are susceptible to damage by electrostatic or high voltage charges. Damage can be latent, resulting in failures occurring weeks or months later. Therefore, special precautions must be taken to prevent device damage during disassembly, troubleshooting, and repair.

Handling precautions are mandatory for CMOS circuits and are especially important in low humidity conditions. DO NOT attempt to disassemble the radio without first referring to the following CAUTION statement.



CAUTION: This radio contains static-sensitive devices. Do not open the radio unless you are properly grounded. Take the following precautions when working on this unit:

- Store and transport all CMOS devices in conductive material so that all exposed leads are shorted together. Do not insert CMOS devices into conventional plastic “snow” trays used for storage and transportation of other semiconductor devices.
- Ground the working surface of the service bench to protect the CMOS device. We recommend using the Motorola Static Protection Assembly (part number 0180386A82), which includes a wrist strap, two ground cords, a table mat, and a floor mat.
- Wear a conductive wrist strap in series with a 100k resistor to ground. (Replacement wrist straps that connect to the bench top covering are Motorola part number RSX4015_).
- Do not wear nylon clothing while handling CMOS devices.
- Do not insert or remove CMOS devices with power applied. Check all power supplies used for testing CMOS devices to be certain that there are no voltage transients present.
- When straightening CMOS pins, provide ground straps for the apparatus used.
- When soldering, use a grounded soldering iron.
- If at all possible, handle CMOS devices by the package and not by the leads. Prior to touching the unit, touch an electrical ground to remove any static charge that you may have accumulated. The package and substrate may be electrically common. If so, the reaction of a discharge to the case would cause the same damage as touching the leads.

4.0 Repair Procedures and Techniques — General

Parts Replacement and Substitution

When damaged parts are replaced, identical parts should be used. If the identical replacement part is not locally available, check the parts list for the proper Motorola part number and order the part from the nearest Motorola Communications parts center listed in the “Piece Parts” section of this manual.

Rigid Circuit Boards

This family of radios uses bonded, multi-layer, printed circuit boards. Since the inner layers are not accessible, some special considerations are required when soldering and unsoldering components. The printed-through holes may interconnect multiple layers of the printed circuit. Therefore, exercise care to avoid pulling the plated circuit out of the hole.

When soldering near the 20-pin and 40-pin connectors:

- Avoid accidentally getting solder in the connector.
- Be careful not to form solder bridges between the connector pins.
- Examine your work closely for shorts due to solder bridges.

5.0 Disassembling and Reassembling the Radio — General

Since these radios may be disassembled and reassembled with the use of only four (board to casting) screws, it is important to pay particular attention to the snaps and tabs, and how parts align with each other.

The following tools are required for disassembling the radio:

- Small flat blade screwdriver
- Dismantling Tool (Motorola Part No. 6686119B01)
- TORX™ T20 screwdriver

If a unit requires more complete testing or service than is customarily performed at the basic level, send this unit to a Motorola Authorized Service Center. (See Chapter 1 for a list of authorized service centers.)

The following disassembly procedures should be performed only if necessary:

6.0 Radio Disassembly - Detailed

The procedure to remove and replace a Control Head, Top Cover or Transceiver Board is similar for all models of radio. A typical procedure is therefore shown followed by specific disassembly procedures for Control Heads on radio models.

6.1 Control Head Removal

1. Insert the dismantling tool in the groove between the control head and the radio assembly as shown in Figure 2-1.
2. Press on the dismantling tool until the snap connectors on the side of the control head release from the radio assembly.

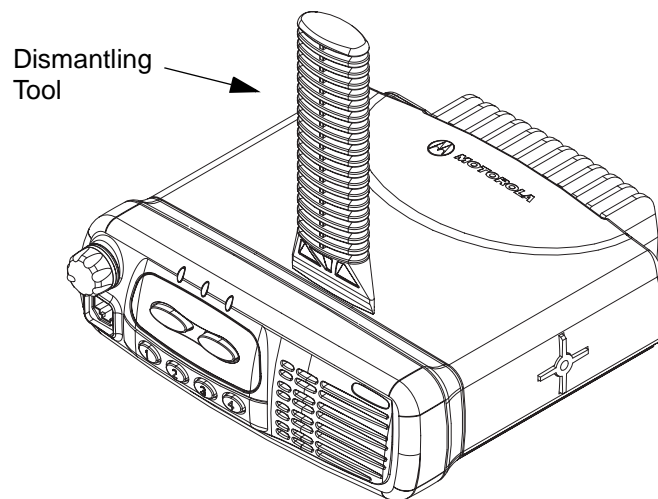

ZWG0130209-O

Figure 2-1 Typical Control Head Removal.

3. Pull the control head away from the radio assembly as shown in Figure 2-2.

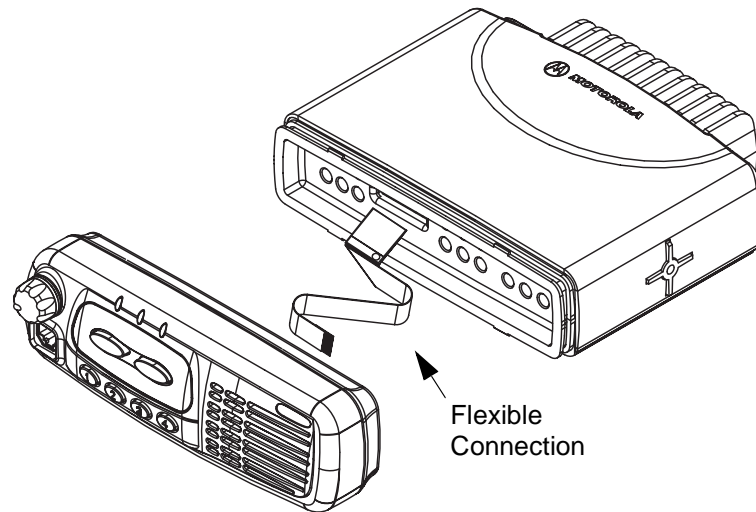

ZWG0130210-O

Figure 2-2 Flexible Connection Removal

4. Remove the flexible connection from the socket on the control head board.

6.2 Top Cover Removal

1. Insert the dismantling tool in the middle of the radio assembly side groove as shown in Figure 2-3.
2. Press on the dismantling tool until the snap connectors on the side of the cover release from the radio chassis.
3. Lift the top cover from the chassis.

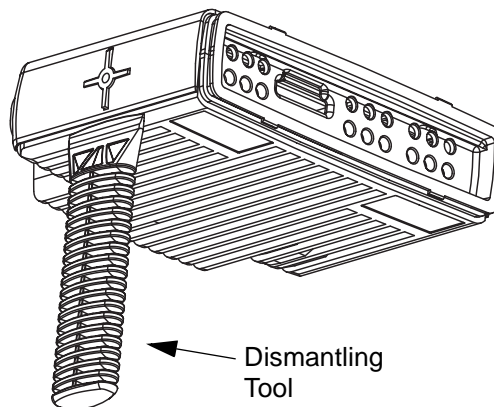

ZWG0130211-O

Figure 2-3 Top Cover Removal.

6.3 Transceiver Board Removal

1. Remove six screws from the diecast cover using the T20 TORX™ driver as shown in Figure 2-4.
2. Lift the cover from the chassis.

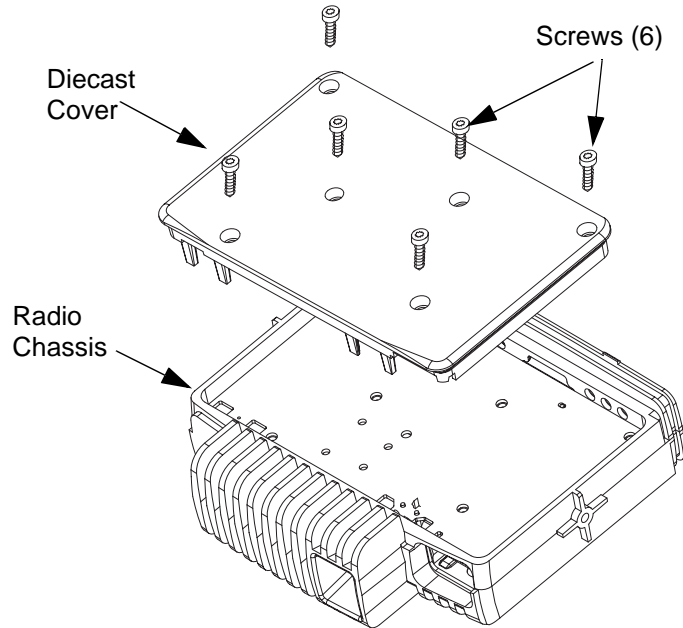

ZWG0130212-O

Figure 2-4 Diecast Cover Removal.

3. Slowly lift the transceiver board on the edge at the front of the radio (the edge that mates with the control head) and pull gently toward the front of the radio as shown in Figure 2-5. Take care to slide the antenna connector and power connector out of the chassis towards the front.



CAUTION: The thermal grease or pads can act as an adhesive and cause the leads of the heat dissipating devices to be over stressed if the board is lifted too quickly.

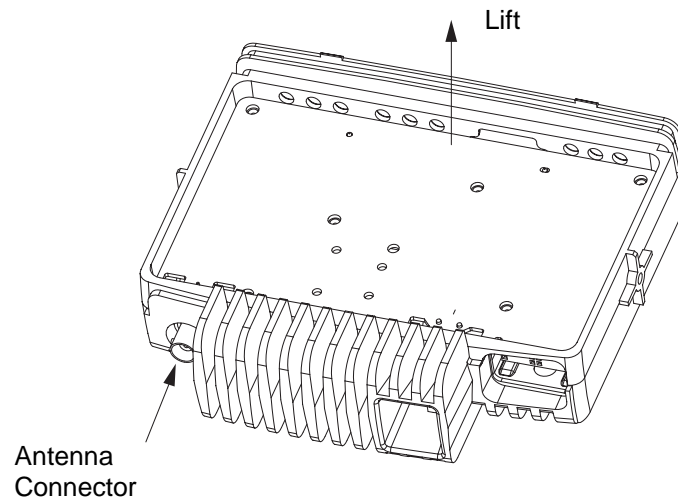

ZWG0130213-O

Figure 2-5 Transceiver Board Removal

6.4 Disassembly of Control Heads

1. To dismount the control head housing from the back housing, insert the dismantling tool in the groove between the two housings as shown in Figure 2-6.

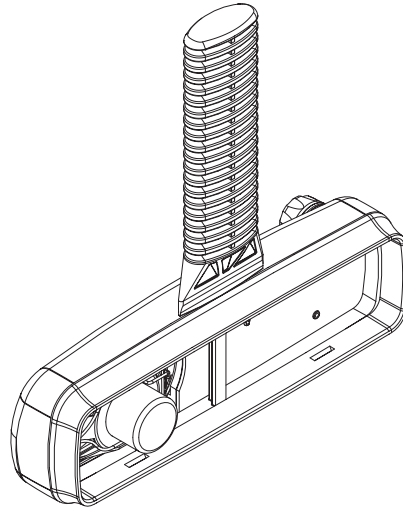

ZWG0130214-O

Figure 2-6 Control Head Back Housing Removal

2. Press the dismantling tool until the snap connectors on the side of the back housing release from the control head.
3. Disconnect the speaker socket and pull out the speaker (with speaker tube) by stretching the control head housing, Figure 2-7 (GM338 only).

NOTE The speaker and speaker tube are glued together to form one unit.

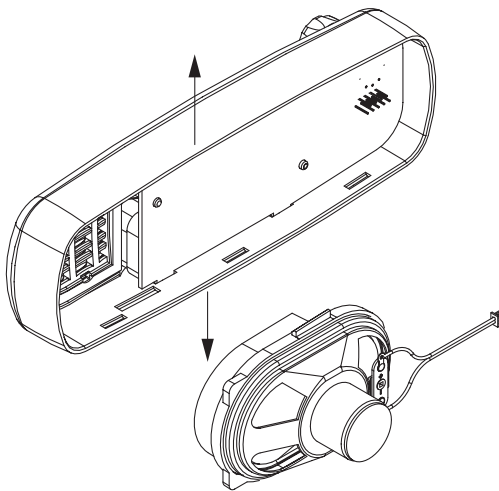

ZWG0130218-O

Figure 2-7 Speaker and Speaker Tube Removal

4. Remove the board from the control head housing by stretching the control head housing and pulling up on the board as shown in Figure 2-8 and Figure 2-9.

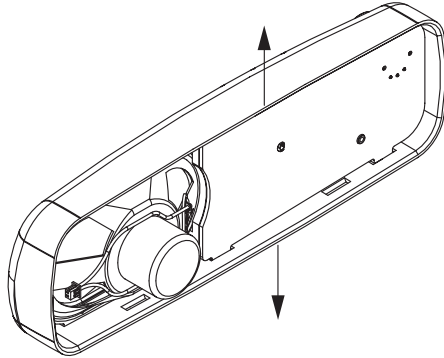

ZWG0130215-O

Figure 2-8 Control Head Board Removal

5. Remove the keypad from the control head housing by lifting up the rubber keypad.
6. Remove the display and the top and bottom elastomeric connectors from the control head housing.

NOTE Care should be taken not to touch or contaminate the conductive pads on the under side of the keypad, the elastomeric connectors or the conductive contacts on the printed circuit board .

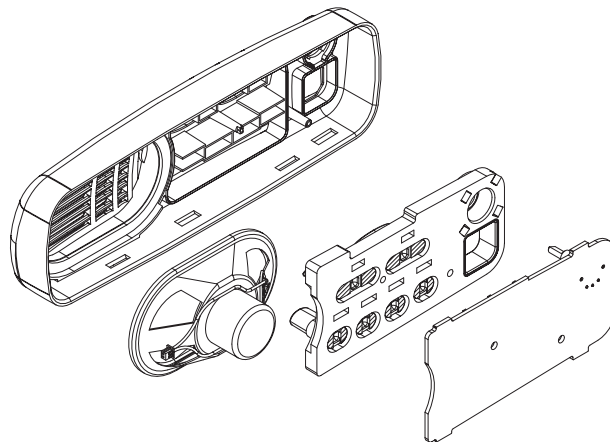

ZWG0130216-O

Figure 2-9 Board, Keypad and Speaker Removal

7.0 Radio Assembly

7.1 Control Heads - GM338 and GM398

1. On the GM338 only, locate the display in the control head ensuring that the two cut-outs in the display are aligned with their corresponding indentations, then press the display into place. Insert the top and bottom elastomeric connector strips into the spaces above and below the display respectively.

NOTE Care should be taken not to touch or contaminate the conductive pads on the underside of the display and the elastomeric connectors (GM338 only).

2. Fit the rubber keypad onto the board ensuring that the ON/OFF control and microphone on the board locate correctly with the cut-outs in the keypad.
3. On the board, rotate the ON/OFF control spindle fully counter-clockwise.
4. Also, rotate the volume knob on the front housing fully counter-clockwise.
5. Align the board with the control head, inserting the ON/OFF control spindle and microphone connector through the holes in the control head.
6. Ensure that the keypad, ON/OFF control spindle and microphone connector are aligned with the control head then press the board into place until it clicks.
7. On the GM338, insert the speaker tube and speaker into the control head and press it in until it clicks. Connect the speaker connector to the board.

7.2 Radio Chassis And Transceiver Board

1. Inspect the transceiver board chassis and if required reapply thermal grease to the heatsink area on the chassis and heat dissipating devices. You may have to remove damaged thermal pads from the chassis and devices prior to applying the grease.
2. Insert the transceiver board at an angle (approximately 30°) into the chassis taking care to slide the antenna connector and accessory connector into their cut-outs in the chassis.
3. Lower the transceiver board onto the chassis and align the two locating holes in the board with the locating pins in the chassis.
4. Secure the cover to the chassis with the six screws previously removed.
5. Torque the six screws to 1.9 NM (17 in lbs) using the T20 TORX™ driver. Begin with the two screws located in the middle of the chassis followed by the four outer screws. Since the screws usually take a set, torque the screws a second time (1.9 NM) in the same order.
6. Refit the top cover over the assembled radio chassis. Press the cover down until it snaps into place.

7.3 Control Head Fitting

1. Align the "0" mark on the flex with the "0" mark on the chassis to the socket on the radio assembly as shown in Figure 2-2.
2. Check that the back housing o-ring seal is undamaged and fitted in the groove. Replace the seal if it is damaged (refer to the exploded view diagrams and parts list).
3. Fit the back housing to the control head. Ensure that the tags on the back housing align with the snap catch grooves on the control head. Press the back housing into place until it snaps into place.
4. Check that the radio chassis o-ring seal is undamaged and fitted in the groove on the chassis assembly. Replace the seal if it is damaged.

8.0 Radio Exploded Mechanical Views and Parts Lists

8.1 Radio Assembly

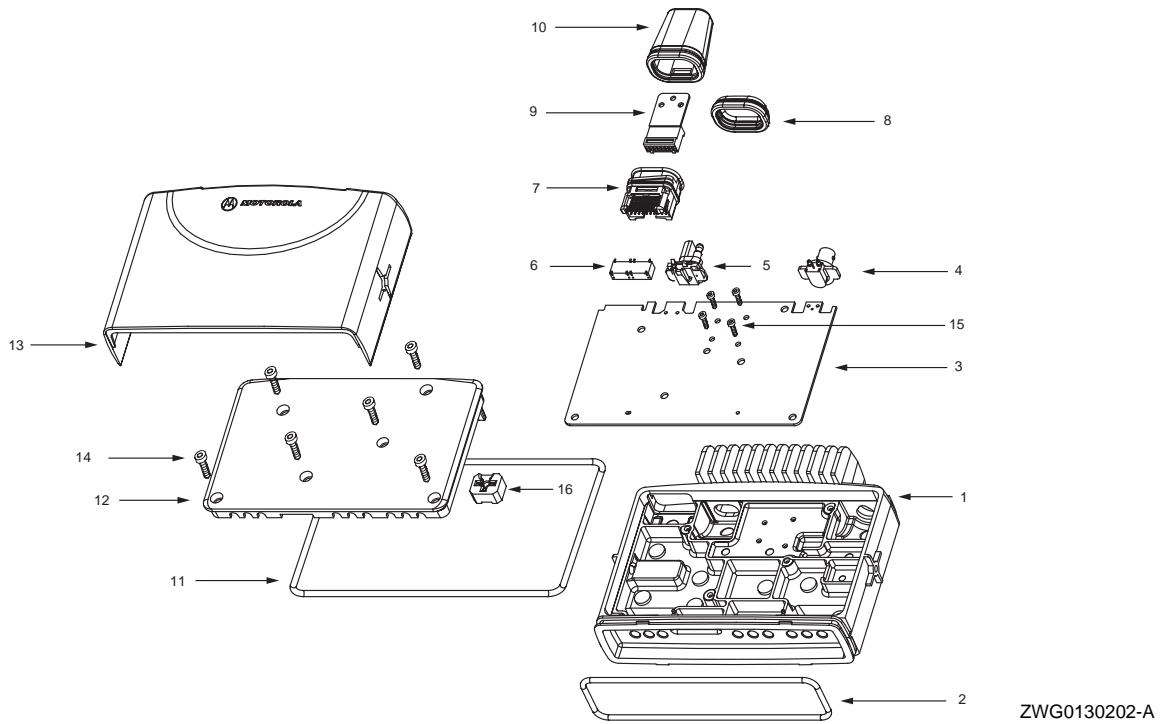

ZWG0130202-A

Figure 2-10 Radio Assembly

Item No.	Description	Part Number
1	Chassis 25W	2786082B02
2	Gasket, Controlhead	3202620Y01
3	Main PCB (items 4, 5 and 6 included)	
4	Antenna Connector with Gasket, BNC	0986166B01
5	Power Connector	0986165B01
6	Connector 20 PIN	0986105B01
7	Connector Assembly	2886122B02
8	Gasket Cover	3202607Y01
9	Connector Housing (Optional extra)	1580922V01
10	Gasket Accessory Connector (Optional extra)	3202606Y01
11	Gasket Cover 25W	3286085B01
12	Cover 25W	1586084B01
13	Cover, Plastic 25W	1586083B01
14	Screw T20, 6x (M4)	0310911A30
15	Screw T8 Power Device Fastner (some models only)	0310911A12
16	Silicon Pressure pad, Power devices (25W cover only)	7586187B01

8.2 Control Head - GM338

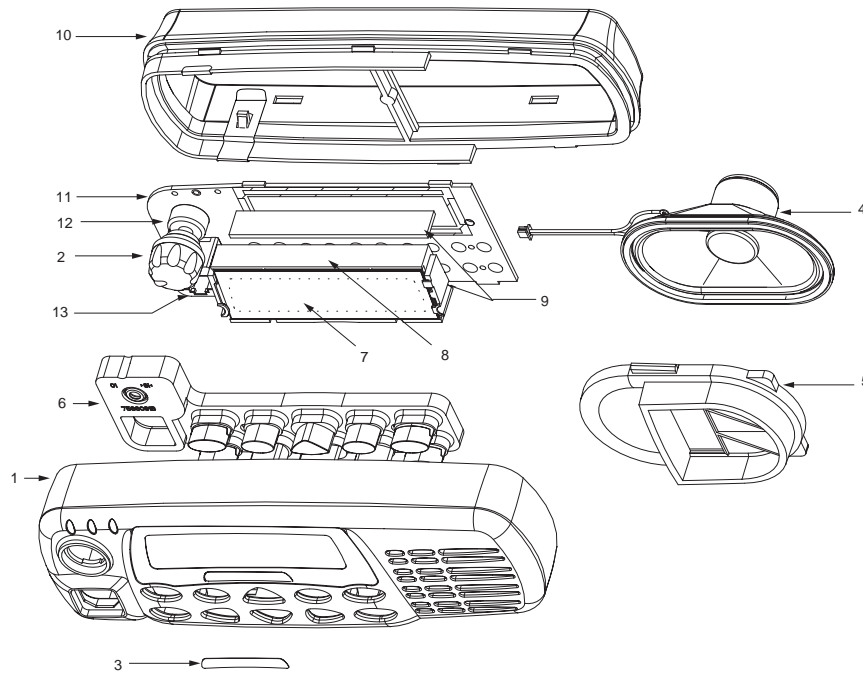

ZWG0130200-A

Figure 2-11 Control Head - GM338

Item no	Description	Part No.
1	Housing Front Gasket, Lens, Lightguide	1586088B01
2	Knob, Volume	3686098B02
3	Label	1364279B17
4	Speaker	5086126B01
5	Tube, Speaker with Gasket	3786107B01
6	Keypad, including: Keypad Button	7586091B02 3886134B--
7	LCD Glass	7286104B01
8	Frame LCD	0786099B01
9	Conn. Elastomeric (Top and Bottom)	2886130B01 2886130B02
10	Back Housing, including: Back Housing, O-ring Back Housing, Grounding Clip	1586093B02 3286094B01 3986218B01
11	PCB Kit	GLN7353_
12	Potentiometer	1805911V02
13	10 PIN Microphone Jack	2864287B01
(not shown)	Flex, 12 Position Connector (Controlhead to Radio)	8486127B01

8.3 Control Head - GM398

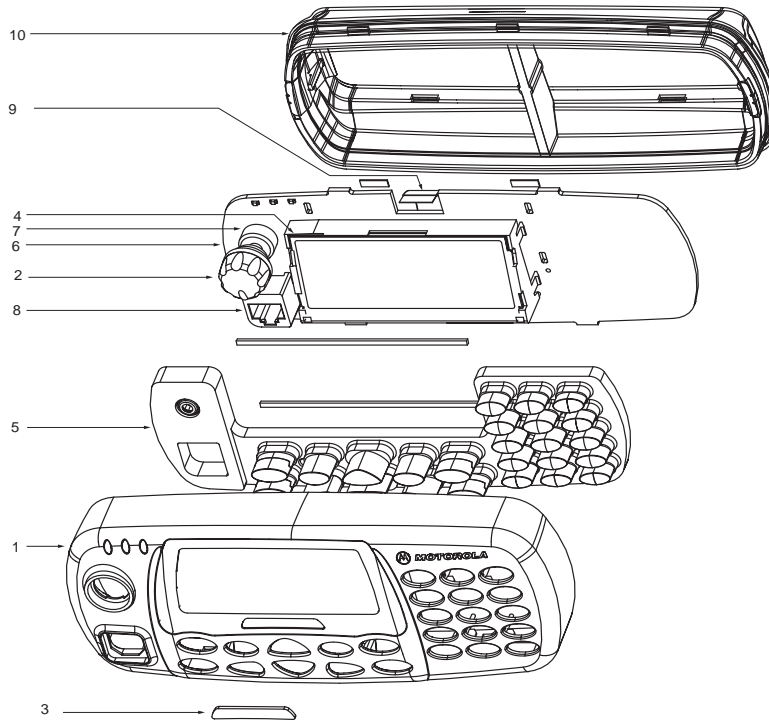

ZWG0130201-O

Figure 2-12 Control Head - GM398

Item No	Description	Part No
1	Housing Front, including: Gasket, Lens, Lightguide	1564304B01
2	Knob, Volume	3686098B02
3	Label	1364279B18
4	LCD Module	5164313B01
5	Keypad, including: Keypad Button	7564314B01 3886134B--
6	PCB Kit	GLN7361_
7	Potentiometer	1805911V02
8	10 PIN Microphone Jack	2864287B01
9	Flex, 24 Position connector	8464346B02
10	Backhousing, including: Back housing O-ring Grounding Clip, left Grounding Clip, right	1564305B01 3286094B01 3908450X02 3908451X02
(not shown)	Flex, 12 Position Connector (Controlhead to Radio)	8486127B01

9.0 Service Aids

Table 2-1 lists the service aids recommended for working on the radio. While all of these items are available from Motorola, most are standard workshop equipment items, and any equivalent item capable of the same performance may be substituted for the item listed.

Table 2-1 Service Aids

Motorola Part No.	Description	Application
RLN4460_	Portable Test Set	Enables connection to audio/accessory jack. Allows switching for radio testing.
RKN4081_	Programming Cable with Internal RIB	Includes radio interface box (RIB) capability.
RLN4853_	10 to 20 Pin Adapter	Connects RKN4081 to radio accessory conn.
RKN4083_	Mobile Programming/Test Cable	Connects radio to RIB (RLN4008_).
GTF374_	Program Cable	Connects RIB to Radio microphone input
RLN4008_	Radio Interface Box	Enables communications between radio and computer's serial communications adapter.
HLN8027_	Mini UHF to BNC Adaptor	Adapts radio antenna port to BNC cabling of test equipment.
GPN6133_	Power Supply	Provides the radio with power when bench testing.
EPN4040_	Wall-Mounted Power Supply	Used to supply power to the RIB (UK).
EPN4041_	Wall-Mounted Power Supply	Used to supply power to the RIB (Euro)
8180384J59	Housing Eliminator (short)	Test Fixture used to bench test the radio PCB
8180384J60	Housing Eliminator (medium)	Test Fixture used to bench test the radio PCB
8180384J61	Housing Eliminator (long)	Test Fixture used to bench test the radio PCB
3080369B71	Computer Interface Cable	Connects the RIB to the Computer (25-pin)
3080369B72	Computer Interface Cable	Connects the RIB to the Computer (9-pin) (Use for IBM PC AT - other IBM models use the B71 cable above)
6686119B01	Removal Tool	Assists in the removal of radio control head.

10.0 Test Equipment

Table 2-2 lists test equipment required to service the radio and other two-way radios.

Table 2-2 Recommended Test Equipment

Motorola Part No.	Description	Characteristics	Application
R2600_NT	Comms System Analyzer (non MPT)	This monitor will substitute for items with an asterisk *	Frequency/deviation meter and signal generator for wide-range troubleshooting and alignment
R2680_NT	Comms System Analyzer (MPT1327) to be ordered with RLN1022_ (H/W) RLN1023_ (S/W)	This monitor will substitute for items with an asterisk *	Frequency/deviation meter and signal generator for wide-range troubleshooting and alignment
*R1072_	Digital Multimeter		AC/DC voltage and current measurements
*R1377_	AC Voltmeter	100 μ V to 300 V, 5Hz-1MHz, 10 Mega Ohm input impedance	Audio voltage measurements
WADN4133_	Delay Oscilloscope	2 Channel 40 MHz bandwidth, 5 mV/cm - 20 V/cm	Waveform measurements
R1440_ 0180305F17 0180305F31 0180305F40 RLN4610_ T1013_	Wattmeter, Plug-in Elements Plug-in Elements Plug-in Elements Carry case RF Dummy Load	ThruLine 50-Ohm, \pm 5% accuracy 10W, 25 - 60 MHz 10W, 100 - 250 MHz 10W, 200 - 500 MHz Wattmeter and 6 elements	Transmitter power output measurements
S1339_	RF Millivolt Meter	100mV to 3 VRF, 10 kHz to 1.2 GHz	RF level measurements
R1011_/220V	220V Power Supply	0-40V, 0-40A	Programmable

11.0 Programming/Test Cable - RKN4083_

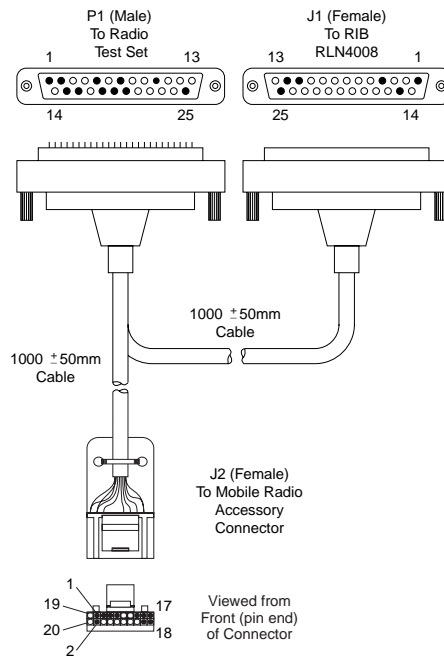

FLO830308-0

Figure 2-13 Programming/Test Cable

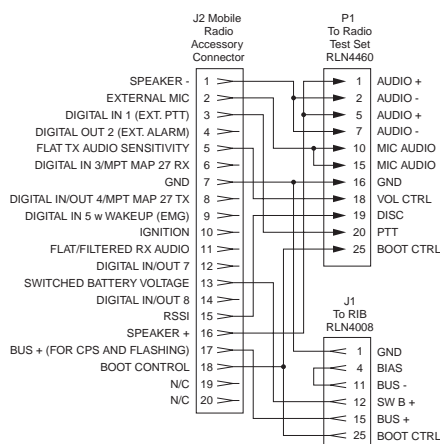

FLO830307-0

Figure 2-14 Pin Configuration of the Side Connector

THIS PAGE INTENTIONALLY LEFT BLANK

Section 3

TRANSCEIVER PERFORMANCE TESTING

1.0 General

These radios meet published specifications through their manufacturing process by utilizing high-accuracy laboratory-quality test equipment. The recommended field service equipment approaches the accuracy of the manufacturing equipment with few exceptions. This accuracy must be maintained in compliance with the manufacturer's recommended calibration schedule.

2.0 Setup

Supply voltage is provided using a 13.2Vdc power supply. The equipment required for alignment procedures is connected as shown in the Radio Tuning Test Setup Diagram, Figure 4-4.

Initial equipment control settings should be as indicated in Table 3-1. The remaining tables in this chapter contain the following related technical data:

Table Number	Title
3-2	Test Environments
3-3	Test Channel Spacing
3-4	Test Frequencies
3-5	Transmitter Performance Checks
3-6	Receiver Performance Checks

Table 3-1 Initial Equipment Control Settings

Service Monitor	Test Set	Power Supply
Monitor Mode: Power Monitor	Spkr set: A	Voltage: 13.2Vdc
RF Attn: -70	Spkr/load: Speaker	DC On/Standby: Standby
AM, CW, FM: FM	PTT: OFF	Volt Range: 20V
Oscilloscope Source: Mod Oscilloscope Horiz: 10mSec/Div Oscilloscope Vert: 2.5kHz/Div Oscilloscope Trig: Auto Monitor Image: Hi Monitor BW: Nar Monitor Squelch: mid CW Monitor Vol: 1/4 CW		Current: 20A

3.0 RF Test Mode

When the radio is operating in its normal environment, the radio's microcontroller controls the RF channel selection, transmitter key-up, and receiver muting. However, when the unit is on the bench for testing, alignment, or repair, it is removed from its normal environment and cannot receive commands from its system. Therefore, the internal microcontroller does not key the transmitter or unmute the receiver. This prevents the use of a normal tuning procedure. To solve this problem, a special "test mode" is incorporated into the radio.

To enter test mode (display radios):

1. Turn the radio on.
2. Within ten seconds after the self test is complete, press button P2, five times in succession.
3. After "CSQ CHXX SP25" appears in the display, the radio is on channel XX, carrier squelch mode, 25 kHz channel spacing.
4. Each additional press of P2 scrolls through to the next channel spacing and a corresponding set of tones are sounded.
5. Pressing P1 scrolls through and accesses test environments as shown in 3-2.
6. Pressing P2 for three seconds switches the radio to the control head test mode. 'LCD Test' appears on the display.
7. Pressing P1 causes the radio to turn on all the dots of the first character. Another P1 press turns on all the dots of the next character and so on until the last character.
8. Pressing P1 at the end of the LCD test activates the 'Icon Test'. The next P1 press turns on the first icon.
9. Pressing P1 at the end of the Icon test activates the "Button Test" mode. Pressing any button (except P1) or any keypad button during the LCD test or Icon test immediately activates this test.
10. Pressing P2 for 3 seconds in the control head test mode causes the radio to return to the RF test mode.

Table 3-2 Test Environments

No. of Beeps	Description	Function
1 (high pitch)	Carrier Squelch (CSQ)	RX: unsquelch if carrier detected TX: mic audio
1	Tone Private-Line (TPL)	RX: unsquelch if carrier and tone (192.8Hz) detected TX: mic audio + tone (192.8Hz)
2	Digital Private-Line (DPL)	RX: unsquelch if carrier and digital code (131) detected TX: mic audio + digital code (131)
3	Dual-Tone multiple frequency (DTMF)	RX: unsquelch if carrier detected TX: selected DTMF tone pair
5	Unsquelch (Open)	RX: constant unsquelch TX: mic audio
9	MDC1200 (HSS)	RX: unsquelch if carrier detected TX: 1500 Hz tone
11	CMP	RX: unsquelch if carrier detected TX: mic audio
12	LLE	RX: unsquelch if carrier detected TX: mic audio

Table 3-3 Test Channel Spacing

Number of Beeps	Channel Spacing
1	25 kHz
2	12.5 kHz
3	20 kHz

Table 3-4 Test Frequencies

Test Mode	Test Channel Low Power	Test Channel High Power	Low Band Range 1 29.7-36 MHz	Low Band Range 2 36-42 MHz	Low Band Range 3 42-50 MHz	VHF	UHF1	UHF2
TX	1	8	29.725	30.025	42.025	136.025	403.025	450.025
RX	1	8	29.750	36.050	42.050	136.050	403.050	450.050
TX	2	9	30.225	37.125	43.225	142.325	414.150	462.825
RX	2	9	30.325	37.225	43.125	142.350	414.175	462.850
TX	3	10	31.025	38.225	44.525	148.625	425.325	475.650
RX	3	10	31.125	38.325	44.425	148.650	425.350	475.675
TX	4	11	32.125	39.125	46.125	154.975	436.475	488.475
RX	4	11	32.225	39.225	46.025	155.025	436.525	488.525
TX	5	12	33.025	40.225	47.525	161.225	447.650	501.325
RX	5	12	33.125	40.325	47.425	161.250	447.675	501.350
TX	6	13	34.225	41.025	48.125	167.525	458.825	514.125
RX	6	13	34.325	41.125	48.025	167.550	458.850	514.150
TX	7	14	35.950	41.950	49.950	173.950	469.950	526.950
RX	7	14	35.975	41.975	49.975	173.975	469.975	526.975

Table 3-5 Transmitter Performance Checks

Test Name	Communications Analyzer	Radio	Test Set	Comment
Reference Frequency	Mode: PWR MON 4th channel test frequency* Monitor: Frequency error Input at RF In/Out	TEST MODE, Test Channel 4 carrier squelch	PTT to continuous (during the performance check)	Frequency error: ± 150 Hz VHF, ± 150 Hz UHF
Power RF	As above	As above	As above	Low Power: 0.8-1.4 W. High Power: 25-30W
Voice Modulation	Mode: PWR MON 4th channel test frequency* atten to -70, input to RF In/ Out Monitor: DVM, AC Volts Set 1kHz Mod Out level for 800mVrms at test set, 800mVrms at AC/DC test set jack	As above	As above, meter selector to mic	Deviation: 2.5 kHz Max. (12.5 kHz Ch. Sp.). 4 kHz Max. (20 kHz Ch. Sp.). 5 kHz Max. (25 kHz Ch. Sp.).
Voice Modulation (internal)	Mode: PWR MON 4th channel test frequency* atten to -70, input to RF In/ Out	TEST MODE, Test Channel 4 carrier squelch output at antenna	Remove modulation input	Deviation: 2.5 kHz Max. (12.5 kHz Ch. Sp.). 4 kHz Max. (20 kHz Ch. Sp.). 5 kHz Max. (25 kHz Ch. Sp.).
High-Speed Data Modulation**	As above	TEST MODE, Test Channel 4 high speed output at antenna	PTT to continuous (during the performance check).	Deviation: 1.3-1.7 kHz (12.5 kHz Ch. Sp.). 2.1-2.7 kHz (20 kHz Ch. Sp.). 2.6-3.4 kHz (25 kHz Ch. Sp.).
DTMF Modulation	As above, 4th channel test frequency*	TEST MODE, Test Channel 4 DTMF output at antenna	As above	Deviation: 1.4-1.9 kHz (12.5 kHz Ch. Sp.). 2.3-3.0 kHz (20 kHz Ch. Sp.). 2.9-3.8 kHz (25 kHz Ch. Sp.).
PL/DPL Modulation	As above 4th channel test frequency* BW to narrow	TEST MODE, Test Channel 4 TPL DPL	As above	Deviation: 0.25-0.5 kHz (12.5 kHz Ch. Sp.). 0.4-0.8 kHz (20 kHz Ch. Sp.). 0.5-1.0 kHz (25 kHz Ch. Sp.).

* See 3-4

** MPT

Table 3-6 Receiver Performance Checks

Test Name	Communications Analyzer	Radio	Test Set	Comment
Reference Frequency	Mode: PWR MON 4th channel test frequency* Monitor: Frequency error Input at RF In/Out	TEST MODE, Test Channel 4 carrier squench output at antenna	PTT to continuous (during the performance check)	Frequency error to be ± 150 Hz VHF ± 150 Hz UHF
Rated Audio	Mode: GEN Output level: 1.0mV RF 4th channel test frequency* Mod: 1kHz tone at 3kHz deviation Monitor: DVM: AC Volts	TEST MODE Test Channel 4 carrier squench	PTT to OFF (center), meter selector to Audio PA	Set volume control to 8.12Vrms
Distortion	As above, except to distortion	As above	As above	Distortion <5.0%
Sensitivity (SINAD)	As above, except SINAD, lower the RF level for 12dB SINAD.	As above	PTT to OFF (center)	RF input to be <0.3 μ V
Noise Squelch Threshold (only radios with conventional system need to be tested)	RF level set to 1mV RF	As above	PTT to OFF (center), meter selection to Audio PA, spkr/ load to speaker	Set volume control to 3.16Vrms
	As above, except change frequency to a conventional system. Raise RF level from zero until radio unsquelches.	out of TEST MODE; select a conventional system	As above	Unsquelch to occur at <0.25 μ V. Preferred SINAD = 9-10dB

* See 3-4

Section 4

RADIO TUNING AND PROGRAMMING

1.0 Introduction

This chapter provides an overview of the Customer Programming Software (CPS) and tuner program which are designed for use in a Windows 95/98 environment. These programs are available in separate kits as listed in the Table 4-1. An Installation instruction manual is also included with each kit.

NOTE Refer to the appropriate program on-line help files for the programming procedures.

Table 4-1 Software Installation Kits Radio Tuning Setup

Description	Kit Number
Customer Programming Software (CPS) CD	PMVN4043D
Customer Programming Software (CPS) Disk	PMVN4031D

2.0 CPS Programming Setup

The CPS programming setups, shown in Figure 4-1 through Figure 4-3, are used to program the radio.

NOTE Refer to appropriate program on-line help files for the programming procedures.

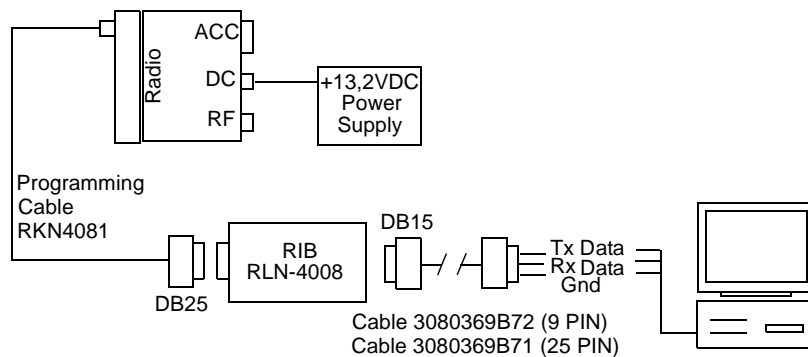

ZWG0130338-0

Figure 4-1 CPS Programming Setup with RIB

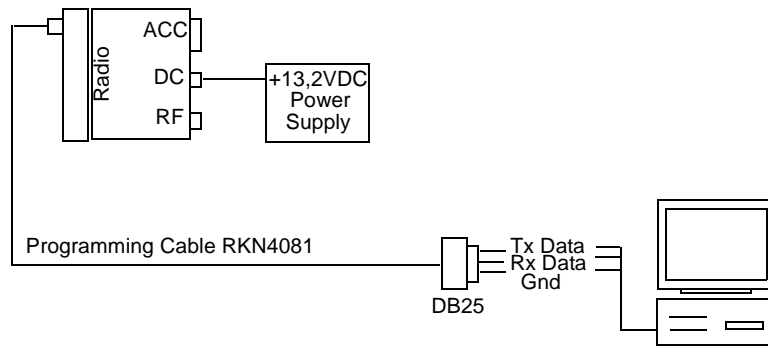

ZWG0130339-0

Figure 4-2 CPS Programming Setup Cable with Internal RIB

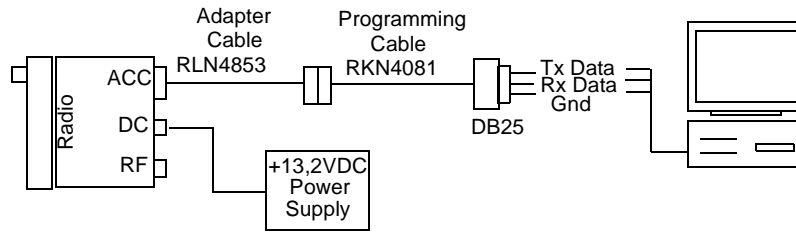

ZWG0130340-0

Figure 4-3 CPS Programming Setup Cable with Internal RIB and Rear Adapter Cable

3.0 Radio Tuning Setup

A personal computer (PC), Windows 95/98 and a tuner program are required to tune the radio. To perform the tuning procedures, the radio must be connected to the PC, radio interface box (RIB), and test equipment setup as shown in Figure 4-4.

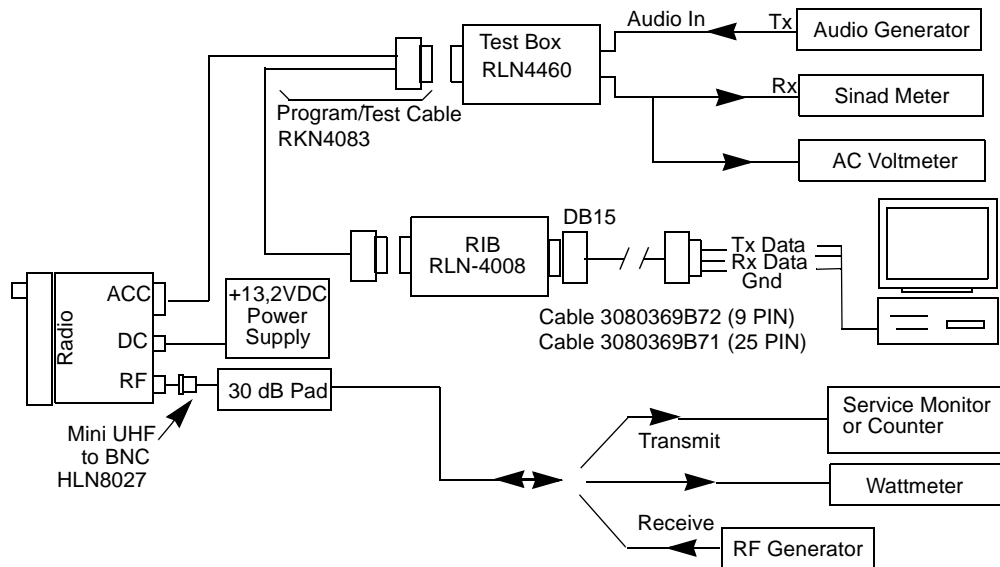

ZWG0130336-0

Figure 4-4 Radio Tuning Test Equipment Setup with External RIB

3.1 Initial Test Equipment Control Settings

The initial test equipment control settings are listed in Table 4-2.

Table 4-2 Initial Test Equipment Control Settings

Service Monitor	Test Set	Power Supply
Monitor Mode: Power Monitor	Speaker set: A	Voltage: 13.2Vdc
RF Attenuation: -70	Speaker/load: Speaker	DC On/Standby: Standby
AM, CW, FM: FM	PTT: OFF	Volt Range: 20V
Oscilloscope Source: Mod Oscilloscope Horizontal: 10mSec/Div Oscilloscope Vertical: 2.5 kHz/Div Oscilloscope Trigger: Auto Monitor Image: Hi Monitor BW: Nar Monitor Squelch: mid CW Monitor Volume: 1/4 CW		Current: 20A

THIS PAGE INTENTIONALLY LEFT BLANK

Section 5

POWER UP SELF-TEST

1.0 Error Codes

Turning on the radio starts a self-test routine that checks the radio functionality. If the checks are successful, the radio generates two high-pitched self-test pass tones, or a musical tone (selected in CPS). If the self-test is not successful, one low-pitched tone is heard. Radios with displays are able to display the error codes. The displayed error codes and related corrections are listed in Table 5-1.

NOTE A radio without a display emits only the 300Hz tone if it fails the test.

Table 5-1 Power Up Error Codes

If the error code displayed is...	then, there is a...	To correct the problem...
"RAM Test"	RAM test failure	Turn radio off-on. If message reoccurs replace main board or return it to the nearest Motorola depot.
"EEPRM HW ERROR"	Codeplug structure mismatch or non existence of codeplug.	Reprogram codeplug with correct version and retest radio. If message reoccurs, replace main board or return to the nearest Motorola depot.
"EEPRM CS ERROR"	Wrong codeplug checksum.	Reprogram the codeplug and retest the radio.
No Display	Display module is not connected. Display module faulty.	Check connection between main board and the display module. Replace display module.
300Hz Tone (Radio Without Display)	Radio failure or invalid codeplug as described above.	Turn radio off then on again. Confirm that there is a 300Hz fail tone. Make the relevant correction as described above.

THIS PAGE INTENTIONALLY LEFT BLANK

Section 6

MODEL CHART AND TEST SPECIFICATION

1.0 Low Power Radios

1.1 Model Chart (VHF 136-174 MHz)

GM Series, VHF 136-174 MHz			
Model		Description	
AZM25KHF9AA5		GM338 136-174 MHz 1-25W	
AZM25KHN9AA8		GM398 136-174 MHz 1-25W	
		Item	Description
X		GCN6114_	GM338 Control Head Direct Mount
	X	GCN6115_	GM398 Control Head Direct Mount
X		IMUD6010_	Tanapa WM 136-174 MHz 1-25W
	X	IMUD6023_	Tanapa WM 136-174 MHz 1-25W
X	X	RAD4198_	BNC 136-144 MHz, 1/4 Wave Roof Mount
X	X	RAD4199_	BNC 146-150.8 MHz, 1/4 Wave Roof Mount
X	X	RAD4200_	BNC 150.8-162 MHz, 1/4 Wave Roof Mount
X	X	RAD4201_	BNC 162-174 MHz, 1/4 Wave Roof Mount
X	X	RAD4202_	BNC 146-172 MHz, 3dB Gain Roof Mount
X		6804112J06	GM338 User Guide
	X	6804112J07	GM398 User Guide

x = Indicates one of each is required.

1.2 Model Chart (UHF Band 1, 403-470 MHz)

GM Series, UHF Band 1, 403-470 MHz		
Model		Description
	AZM25RHF9AA5	GM338 403-470 MHz 1-25W
	AZM25RHN9AA8	GM398 403-470 MHz 1-25W
	Item	Description
X	GCN6114_	GM338 Control Head Direct Mount
	X GCN6115_	GM398 Control Head Direct Mount
X	IMUE6021_	Tanapa WM 403-470 MHz 1-25W
	X IMUE6039_	Tanapa WM 403-470 MHz 1-25W
X	X RAE4151_	BNC 403-430 MHz, 1/4 Wave Roof Mount
X	X RAE4158_	BNC 406-420 MHz, 3.5dB Gain Roof Mount
X	X RAE4152_	BNC 450-470 MHz, 1/4 Wave Roof Mount
X	X RAE4153_	BNC 450-470 MHz, 3.5dB Gain Roof Mount
X	X RAE4154_	BNC 450-470 MHz, 5dB Gain Roof Mount
X	6804112J06	GM338 User Guide
	X 6804112J07	GM398 User Guide

x = Indicates one of each is required.

1.3 Model Chart (UHF Band 2, 450-527 MHz)

GM Series, UHF Band 2, 450-527 MHz			
Model		Description	
		AZM25SHF9AA5	GM338 450-527 MHz 1-25W
		AZM25SHN9AA8	GM398 450-527 MHz 1-25W
		Item	Description
X		GCN6114_	GM338 Control Head Direct Mount
	X	GCN6115_	GM398 Control Head Direct Mount
X		IMUE6022_	Tanapa WM 450-527 MHz 1-25W
	X	IMUE6043	Tanapa WM 450-527 MHz 1-25W
X	X	RAE4155_	BNC 470-512 MHz, 1/4 Wave Roof Mount
X	X	RAE4156_	BNC 470-494 MHz, 3.5 Gain Roof Mount
X	X	RAE4157_	BNC 494-512 MHz, 5dB Gain Roof Mount
X		6804112J06	GM338 User Guide
	X	6804112J07	GM398 User Guide

x = Indicates one of each is required.

1.4 Model Chart (Low Band, 29.7-50.0 MHz)

GM Series, Low Band, 29.7-50.0 MHz			
Model		Description	
		AZM25BKF9AA5	GM338 29.7-36.0 MHz 40-60W
		AZM25CKF9AA5	GM338 36.0-42.0 MHz 40-60W
		AZM25DKF9AA5	GM338 42.0-50.0 MHz 40-60W
		Item	Description
X	X	X	GCN6114_ Preferred Control Head Direct Mount
X			IMUB6000_ Tanapa WM 29.7-36.0 MHz 40-60W
	X		IMUB6001_ Tanapa WM 36.0-42.0 MHz 40-60W
		X	IMUB6002_ Tanapa WM 42.0-50.0 MHz 40-60W
X			RAB4002 Low Band 29.7-36.0 MHz, 1/4 Wave Base Loaded
	X		RAB4003 Low Band 36.0-42.0 MHz, 1/4 Wave Base Loaded
		X	RAB4004 Low Band 42.0-50.0 MHz, 1/4 Wave Base Loaded
X	X	X	6804112J06 GM338 User Guide

x = Indicates one of each is required.

1.5 Specifications

General				
Specification	VHF	UHF1	UHF2	LOW BAND
Frequency Range:	136-174 MHz	403-470 MHz	450-527 MHz	Low Band 1 (29.7-36.0 MHz) Low Band 2 (36.0-42.0 MHz) Low Band 3 (42.0-50.0 MHz)
Frequency Stability (-30°C to +60°C, 25°C Ref.)	±2.5 PPM	±2 PPM		±5 PPM
Channel Spacing:	12.5/20/25 kHz			12.5/20/30 kHz
Power Output:	1-25W			40-60W
Power Supply:	13.2Vdc (10.8 - 15.6 Vdc) negative vehicle ground			
Dimensions (L X W X H)				
GM338:	186mm X 179mm X 59mm (add 9mm for Volume Knob) (7.32" X 7.05" X 2.34" - add 0.35" for Volume Knob)			60mm X 179mm X 250mm (add 9mm for Volume Knob)
GM398:	188mm X 185mm X 72mm (add 7mm for Volume Knob) (7.4" X 7.28" X 2.83" - add 0.27" for Volume Knob)			56mm X 176mm X 241mm (add 8mm for Volume Knob)
Weight:	1400 g (3.15 lbs)			2040 g (4.5 lbs)
Operating Temperature:	-30 to 60 ° C			
Sealing:	Passes rain testing to IP54			
Shock and Vibration:	Meets MIL-STD 810-C,D&E			
Dust:	Meets MIL-STD 810-C,D&E			
Humidity:	50 ° C 95% RH @ 8 hrs			

Transmitter				
Specification	VHF	UHF1	UHF2	LOW BAND
Modulation Limiting:	±2.5 kHz @ 12.5 kHz ±4.0 kHz @ 20 kHz ±5.0 kHz @ 25 kHz			±2.5 kHz @ 12.5 kHz ±5.0 kHz @ 20/30 kHz
FM Hum and Noise:	-40 dB@12.5 kHz -45 dB@ 20/25 kHz			-40 dB @ 12.5 kHz -45 dB @ 20/30 kHz
Conducted/Radiated Emissions:	-36 dBm < 1 GHz -30 dBm > 1 GHz			-26 dBm < 1 GHz
Adjacent Channel Power	-60dB @12.5, -70dB @ 25kHz			-60dB @ 12.5kHz -70dB @ 20/30kHz
Audio Response: (300 to 3000Hz)	+1, -3dB			
Audio Distortion @ 1000 Hz, 60% Rated Maximum Deviation:	3% Typical			

Receiver				
Specification	VHF	UHF1	UHF2	LOW BAND
Sensitivity (12 dB SINAD) : (ETS)	0.30 μV (0.22 μV Typical)			
Intermodulation: (ETS)	>65 dB, >70 dB in Base Mode			>80 dB, >70 dB in Base Mode
Adjacent Channel Selectivity: (ETS)	80 dB @ 25 kHz 75 dB @ 20 kHz 65 dB @ 12.5 kHz	75 dB @ 25 kHz 70 dB @ 20 kHz 65 dB @ 12.5 kHz		80 dB @ 20/30 kHz 65 dB @ 12.5 kHz
Spurious Rejection: (ETS)	80 dB @ 20/25 kHz 75 dB @ 12.5 kHz	75 dB @ 20/25 kHz 70 dB @ 12.5 kHz		80 dB @ 20/30 kHz 70 dB @ 12.5 kHz
Rated Audio:	3W Internal 7.5W External 13W External			3W Internal 13W External
Audio Distortion @ Rated Audio:	3% Typical			
Hum and Noise:	-40 dB @ 12.5 kHz -45 dB @ 20/25 kHz			-45 dB @ 20/30 kHz -40 dB @ 12.5 kHz
Audio Response: (300 to 3000Hz)	+1, -3dB			
Conducted Spurious Emission per FCC Part 15:	-57 dBm <1 GHz -47 dBm >1 GHz			-26 dBm <1 GHz

2.0 High Power Radios

2.1 Model Chart (VHF 136-174 MHz)

GM Series, VHF 136-174 MHz	
Model	Description
AZM25KKF9AA5	GM338 136-174 MHz 25-45W
	Item
	Description
X	GCN6114_
	GM338 Control Head Direct Mount
X	IMUD6011_
	Tanapa WM 136-174 MHz 25-45W
X	RAD4198_
	BNC 136-144 MHz, 1/4 Wave Roof Mount
X	RAD4199_
	BNC 146-150.8 MHz, 1/4 Wave Roof Mount
X	RAD4200_
	BNC 150.8-162 MHz, 1/4 Wave Roof Mount
X	RAD4201_
	BNC 162-174 MHz, 1/4 Wave Roof Mount
X	RAD4202_
	BNC 146-172 MHz, 3dB Gain Roof Mount
X	6804112J06
	GM338 User Guide

x = Indicates one of each is required.

2.2 Model Chart (UHF Band 1, 403-470 MHz)

GM Series, UHF Band 1, 403-470 MHz	
Model	Description
AZM25RKF9AA5	GM338 403-470 MHz 25-40W Conv Pref (Bipolar)
	Item
	Description
X	GCN6114_
	GM338 Control Head Direct Mount
X	IMUE6012_
	Tanapa WM 403-470 MHz 25-40W
X	RAE4151_
	BNC 403-430 MHz, $\frac{1}{4}$ Wave Roof Mount
X	RAE4152_
	BNC 450-470 MHz, $\frac{1}{4}$ Wave Roof Mount
X	RAE4153_
	BNC 450-470 MHz, 3.5dB Gain Roof Mount
X	RAE4154_
	BNC 450-470 MHz, 5dB Gain Roof Mount
X	RAE4158_
	BNC 406-420 MHz, 3.5dB Gain Roof Mount
X	6804112J06
	GM338 User Guide

x = Indicates one of each is required.

2.3 Model Chart (UHF Band 2, 450-520 MHz)

GM Series, UHF Band 2, 450-520 MHz	
Model	Description
AZM25SKF9AA5	GM338 450-520 MHz 25-40W (Bipolar)
	Item
X	GCN6114_ GM338 Control Head Direct Mount
X	IMUE6019_ Tanapa WM 450-520 MHz 25-40W
X	RAE4155_ BNC 470-512 MHz, 1/4 Wave Roof Mount
X	RAE4156_ BNC 470-494 MHz, 3.5 Gain Roof Mount
X	RAE4157_ BNC 494-512 MHz, 5dB Gain Roof Mount
X	6804112J06 GM338 User Guide

x = Indicates one of each is required.

2.4 Model Chart (UHF Band 1, LDMOS, 403-470 MHz)

GM Series, UHF Band 1, 403-470 MHz	
Mode	Description
AZM25RKF9AA5	GM338 403-470 MHz 25-40W Conv Pref (LDMOS)
	Item
X	GCN6114_ GM338 Control Head Direct Mount
X	IMUE6024_ Tanapa WM 403-470 MHz 25-40W
X	RAE4151_ BNC 403-430 MHz, $\frac{1}{4}$ Wave Roof Mount
X	RAE4152_ BNC 450-470 MHz, $\frac{1}{4}$ Wave Roof Mount
X	RAE4153_ BNC 450-470 MHz, 3.5dB Gain Roof Mount
X	RAE4154_ BNC 450-470 MHz, 5dB Gain Roof Mount
X	RAE4158_ BNC 406-420 MHz, 3.5dB Gain Roof Mount
X	6804112J06 GM338 User Guide

x = Indicates one of each is required.

2.5 Model Chart (UHF Band 2, LDMOS, 450-520 MHz)

GM Series, UHF Band 2, 450-520 MHz	
Model	Description
AZM25SKF9AA5	GM338 450-520 MHz 25-40W (LDMOS)
Item	Description
X GCN6114_	GM338 Control Head Direct Mount
X IMUE6019_	Tanapa WM 450-520 MHz 25-40W
X RAE4155_	BNC 470-512 MHz, 1/4 Wave Roof Mount
X RAE4156_	BNC 470-494 MHz, 3.5 Gain Roof Mount
X RAE4157_	BNC 494-512 MHz, 5dB Gain Roof Mount
X 6804112J06	GM338 User Guide

x = Indicates one of each is required.

2.6 Specifications

General			
Specification	VHF	UHF1	UHF2
Frequency Range:	136-174 MHz	403-470 MHz	450-520 MHz
Frequency Stability (-30°C to +60°C, 25°C Ref.)	±2.5 PPM	±2 PPM	
Channel Spacing:	12.5/20/25 kHz		
Power Output:	25-45W	25-40W	
Power Supply:	13.2Vdc (10.8 - 15.6 Vdc) negative vehicle ground		
Dimensions (L X W X H)	186mm X 179mm X 59mm (add 9mm for Volume Knob) (7.32" X 7.05" X 2.34" - add 0.35" for Volume Knob)		
GM338:			
Weight:	1400 g (3.15 lbs)		
Operating Temperature:	-30 to 60 ° C		
Sealing:	Passes rain testing to IP54		
Shock and Vibration:	Meets MIL-STD 810-C,D&E		
Dust:	Meets MIL-STD 810-C,D&E		
Humidity:	50 ° C 95% RH @ 8 hrs		

Transmitter			
Specification	VHF	UHF1	UHF2
Modulation Limiting:	±2.5 kHz @ 12.5 kHz ±4.0 kHz @ 20 kHz ±5.0 kHz @ 25 kHz		
FM Hum and Noise:	-40 dB@12.5 kHz -45 dB@ 20/25 kHz		
Conducted/Radiated Emissions:	-36 dBm < 1 GHz -30 dBm > 1 GHz		
Adjacent Channel Power	-60dB @12.5, -70dB @ 25kHz		
Audio Response: (300 to 3000Hz)	+1, -3dB		
Audio Distortion @ 1000 Hz, 60% Rated Maximum Deviation:	3% Typical		

Receiver			
Specification	VHF	UHF1	UHF2
Sensitivity (12 dB SINAD) : (ETS)	0.30 μV (0.22 μV Typical)		
Intermodulation: (ETS)	>65 dB		
Adjacent Channel Selectivity: (ETS)	80 dB @ 25 kHz 75 dB @ 20 kHz 65 dB @ 12.5 kHz	75 dB @ 25 kHz 70 dB @ 20 kHz 65 dB @ 12.5 kHz	
Spurious Rejection: (ETS)	80 dB @ 20/25 kHz 75 dB @ 12.5 kHz	75 dB @ 20/25 kHz 70 dB @ 12.5 kHz	
Rated Audio:	3W Internal 7.5W External 13W External		
Audio Distortion @ Rated Audio:	3% Typical		
Hum and Noise:	-40 dB @ 12.5 kHz -45 dB @ 20/25 kHz		
Audio Response: (300 to 3000Hz)	+1, -3dB		
Conducted Spurious Emission per FCC Part 15:	-57 dBm <1 GHz -47 dBm >1 GHz		

GLOSSARY OF TERMS

Term	Definition
ALC	Automatic Level Control: a circuit in the transmit RF path that controls RF power amplifier output, provides leveling over frequency and voltage, and protects against high VSWR (Voltage Standing Wave Ratio).
ASFIC	Audio Signalling Filter Integrated Circuit with voice compander.
CD	Compact Disk.
CMP	Compression.
CPS	Customer Programming Software.
CSQ	Carrier Squelch.
DTMF	Dual-Tone Multifrequency.
DPL	Digital Private-Line™.
EEPROM	Electronically Erasable/Programmable Read-Only Memory: used by the radio to store its personality.
Firmware	Software, or a software/hardware combination of computer programs and data, with a fixed logic configuration stored in a read-only memory. Information cannot be altered or reprogrammed.
FGU	Frequency Generation Unit.
GaAs	Gallium Arsenide: a type of crystalline material used in some semiconductors.
ISW	Inbound Signalling Word: data transmitted on the control channel from a subscriber unit to the central control unit.
LCD	Liquid Crystal Display: a module used to display the radio's current operating channel or system and scan status.
LDMOS	Lateral Diffusion MOS.
LH DATA	Longhorn Data: a bidirectional 0-5V, RS-232 line that uses the microcontroller's integrated RS-232 asynchronous serial communications interface (SCI) peripheral.
LLE	Low Level Expander: slight amount of volume expansion; used to improve the signal to noise ratio.
LSH	Low-Speed Handshake: 150 baud digital data sent to the radio during trunked operation while receiving audio.
MDC	Motorola Data Communication.
MRTI	Motorola Radio-Telephone Interconnect: a system that provides a repeater connection to the Public Switched Telephone Network (PSTN). The MRTI allows the radio to access the telephone network when the proper access code is received.
MSK	Minimum-Shift Keying.

OMPAC	Over-Molded Pad-Array Carrier: a Motorola custom package, distinguished by the presence of solder balls on the bottom pads.
OSW	Outbound Signalling Word: data transmitted on the control channel from the central controller to the subscriber unit.
PC Board	Printed Circuit Board.
PL	Private-Line® tone squelch: a continuous sub-audible tone that is transmitted along with the carrier.
PLL	Phase-Locked Loop: a circuit in which an oscillator is kept in phase with a reference, usually after passing through a frequency divider.
PTT	Push-To-Talk: the switch located on the left side of the radio which, when pressed, causes the radio to transmit.
RAM	Random Access Memory: the radio's RAM is loaded with a copy of the EEPROM data.
Registers	Short-term data-storage circuits within the microcontroller.
Repeater	Remote transmit/receive facility that retransmits received signals to improve communications coverage.
RESET	Reset line: an input to the microcontroller that restarts execution.
RF PA	Radio Frequency Power Amplifier.
RIB	Radio Interface Box.
ROM	Read Only Memory.
RSSI	Received Signal-Strength Indicator: a dc voltage proportional to the received RF signal strength.
RPT/TA	Repeater/Talk-Around.
Softpot	Software Potentiometer: a computer-adjustable electronic attenuator.
Software	Computer programs, procedures, rules, documentation, and data pertaining to the operation of a system.
SPI (clock and data lines)	Serial Peripheral Interface: how the microcontroller communicates to modules and ICs through the CLOCK and DATA lines.
Squelch	Muting of audio circuits when received signal levels fall below a pre-determined value.
Standby Mode	An operating mode whereby the radio is muted but still continues to receive data.
System Central Controller	Main control unit of the trunked dispatch system; handles ISW and OSW messages to and from subscriber units (see ISW and OSW).
System Select	The act of selecting the desired operating system with the system-select switch (also, the name given to this switch).
TOT	Time-Out Timer: a timer that limits the length of a transmission.
TPL	Tone Private-line.

μC	Microcontroller.
UHF	Ultra High Frequency.
μP	Microprocessor.
VCO	Voltage-Controlled Oscillator: an oscillator whereby the frequency of oscillation can be varied by changing a control voltage.
VCOBIC	Voltage-Controlled Oscillator Buffer Integrated Circuit.
VHF	Very High Frequency.
VSWR	Voltage Standing Wave Ratio.

Technical Information Updates

As we continue to make engineering enhancements to our products, the information in our Service Manuals need to be updated accordingly. If you wish to be informed of these updates, kindly fill in and fax us your details.

Fax to: 6-04-6124944

**The Technical Publications Coordinator,
Media and Communications,
R&D Department,
Motorola Penang.**

Your Details

Name/Contact Person: _____

Company Name: _____

Address: _____

Telephone No.: _____

Fax No.: _____

Email Address: _____

How would you like to receive the update notification?

Through: mail email fax

Manual No.: 6804112J17

Kindly complete the Service Manual Feedback Form on the next page to help us ensure that you receive the most accurate and complete information.

Service Manual Feedback Form

We believe that reports from users provide valuable information for producing quality manuals. Kindly take a few moments to provide feedback on this manual. Thank you for your cooperation.

Fax to: 6-04-6124944

**The Technical Publications Coordinator,
Media and Communications,
R&D Department,
Motorola Penang.**

1. Please check all the appropriate boxes:

	Complete	Incomplete	Correct	Incorrect	Clear	Confusing	Size Adequate	Size Too Small	Not Covered in this Manual
Disassembly Procedures	<input type="checkbox"/>	<input type="checkbox"/>	<input type="checkbox"/>	<input type="checkbox"/>	<input type="checkbox"/>	<input type="checkbox"/>	<input type="checkbox"/>	<input type="checkbox"/>	<input type="checkbox"/>
Alignment Procedures	<input type="checkbox"/>	<input type="checkbox"/>	<input type="checkbox"/>	<input type="checkbox"/>	<input type="checkbox"/>	<input type="checkbox"/>	<input type="checkbox"/>	<input type="checkbox"/>	<input type="checkbox"/>
Exploded Views	<input type="checkbox"/>	<input type="checkbox"/>	<input type="checkbox"/>	<input type="checkbox"/>	<input type="checkbox"/>	<input type="checkbox"/>	<input type="checkbox"/>	<input type="checkbox"/>	<input type="checkbox"/>
Schematic Diagrams	<input type="checkbox"/>	<input type="checkbox"/>	<input type="checkbox"/>	<input type="checkbox"/>	<input type="checkbox"/>	<input type="checkbox"/>	<input type="checkbox"/>	<input type="checkbox"/>	<input type="checkbox"/>
Circuit Board Details	<input type="checkbox"/>	<input type="checkbox"/>	<input type="checkbox"/>	<input type="checkbox"/>	<input type="checkbox"/>	<input type="checkbox"/>	<input type="checkbox"/>	<input type="checkbox"/>	<input type="checkbox"/>
Electrical Parts List	<input type="checkbox"/>	<input type="checkbox"/>	<input type="checkbox"/>	<input type="checkbox"/>	<input type="checkbox"/>	<input type="checkbox"/>	<input type="checkbox"/>	<input type="checkbox"/>	<input type="checkbox"/>
Exploded View Parts List	<input type="checkbox"/>	<input type="checkbox"/>	<input type="checkbox"/>	<input type="checkbox"/>	<input type="checkbox"/>	<input type="checkbox"/>	<input type="checkbox"/>	<input type="checkbox"/>	<input type="checkbox"/>

2. How do you rate this particular Service Manual?

excellent very good good fair poor

3. Did this Service manual provide you with the information necessary to service and maintain the specific equipment?

very much so generally yes to some extent no

4. We would appreciate any corrections or recommendations for improving this manual. Please include the specific page number(s) of the diagram or procedure in question.

5. General comments/suggestions:

Manual No.: 6804112J17