



PRELIMINARY DATA SHEET

gm5115/gm5115-H gm5125/gm5125-H

OnPanel LCD Panel Controller

*** Genesis Microchip Confidential ***

NOTE: Sections in this data sheet that mention HDCP apply only to the HDCP-enabled chip versions (gm5115-H and gm5125-H). All other sections apply to all chip versions (gm5115, gm5115-H, gm5125, and gm5125-H).

Publication number: C5115-DAT-01H

Publication date: June 2002

Genesis Microchip Inc.

2150 Gold Street, Alviso, P.O. Box 2150, CA USA 95002 Tel: (408) 262-6599 Fax: (408) 262-6365
165 Commerce Valley Dr. West, Thornhill, ON Canada L3T 7V8 Tel: (905) 889-5400 Fax: (905) 889-5422
1096, 12thA Main, Hal II Stage, Indira Nagar, Bangalore-560 008, India, Tel: (91)-80-526-3878, Fax: (91)-80-529-6245
4F, No. 24, Ln 123, Sec 6, Min-Chuan E. Rd., Taipei, Taiwan, ROC Tel: 886-2-2791-0118 Fax: 886-2-2791-0196
143-37 Hyundai Tower, #902, Samsung-dong, Kangnam-gu, Seoul, Korea 135-090 Tel 82-2-553-5693 Fax 82-2-552-4942
Rm2614-2618 Shenzhen Office Tower, 6007 Shennan Blvd, 518040, Shenzhen, Guandong, P.R.C., Tel (0755)386-0101, Fax (0755)386-7874
2-9-5 Higashigotanda, Shinagawa-ku, Tokyo, 141-0022, Japan, Tel 81-3-5798-2758, Fax 81-3-5798-2759
www.genesis-microchip.com / info@genesis-microchip.com

Trademarks: RealColor, Real Recovery, and Ultra-Reliable DVI are trademarks of Genesis Microchip Inc.

© Copyright 2002, Genesis Microchip Inc. All Rights Reserved.

Genesis Microchip Inc. reserves the right to change or modify the information contained herein without notice. It is the customer's responsibility to obtain the most recent revision of the document. Genesis Microchip Inc. makes no warranty for the use of its products and bears no responsibility for any errors or omissions that may appear in this document.

Revision History

Document	Description	Date
C5115-DAT-01A	<ul style="list-style-type: none"> Initial release. 	March 2001
C5115-DAT-01B	<ul style="list-style-type: none"> In Table 18 corrected description of OSC_SEL (on pin ROM_ADDR13). It should be set to 1 to indicate usage of a single-ended clock oscillator. Corrected image and orientation of logo in pin out diagram Figure 2. Added section 4.11.3. 	June 2001
C5115-DAT-01C	<ul style="list-style-type: none"> Replaced all occurrences of CVDD with CVDD_2.5, including pin numbers 26, 88, 134 and 203 to make them consistent with the names of other 2.5V voltage supply signals. 	July 2001
C5115-DAT-01D	<ul style="list-style-type: none"> Pin number 205 name changed from GPIO16/HFS to GPIO16/HFSn and all occurrences of HFS replaced with HFSn to reflect the fact that this signal is active low. Added description of 2-wire serial protocol in section 4.17.2 and Table 24. Removed "Read with Increment" operation description. Corrected mechanical specification in Figure 32. Changes to Table 21 – DC Characteristics: <ul style="list-style-type: none"> - Maximum voltage for 5V-tolerance inputs is 5.5V. - Added maximum current requirements. Added description of OCM Standalone configuration Figure 26. Added Figure 22 – Panel Power Sequencing. 	July 2001
C5115-DAT-01E	<ul style="list-style-type: none"> Added description of gm5125 (SXGA device). Pin names changed to reflect alternate hard-wired functions: <ul style="list-style-type: none"> - pin 50 from GPIO11 to GPIO11/ROM_WEn, - pin 51 from GPIO12 to GPIO12/NVRAM_SDA, - pin 52 from GPIO13 to GPIO13/NVRAM_SCL, - pin 6 from DDC_SCL to GPIO14/DDC_SCL, - pin 7 from DDC_SDA to GPIO15/DDC_SDA, - pin 46 from GPIO6 to GPIO6/TCON_SHC, - pin 47 from GPIO7 to GPIO7/TCON_TDIV. Removed description of 6-wire host interface, since this is not recommended operation. Pin 1 name changed from GPIO17/HDATA0 to GPIO17, and similarly for pins 206, 207 and 208. Corrected maximum ADC sampling frequency in Table 15 and maximum ADC_CLK frequency in Table 22 to 162.5MHz. Added section 4.5 Test Pattern Generator. Added description of TCON_SHC and TCON_TDIV in section 4.13.1. Clarifications to section 4.1 describing clock generation, section 4.7.2 describing sRGB support, and section 4.15.3 describing GPIOs. Removed mention of row attributes in Figure 25. gm5115/25 OSD controller does not have row attributes. Corrected Table 21, Note 3. Pins VDD1_ADC_2.5, VDD2_ADC_2.5, VDD_RX0_2.5, VDD_RX1_2.5 and VDD_RX2_2.5 are digital 2.5V supplies, not analog. Changed signal names SCL and SDA to HCLK and HFSn, respectively in Figure 29, Figure 30, and Figure 31. 	August 2001
C5115-DAT-01F	<ul style="list-style-type: none"> Added note on Front Cover regarding HDCP enabled versions. Added section 4.12 - Energy Spectrum Management (ESM). Added clarification in section 4.13.1 indicating that single bus configurations are supported in XGA column drivers only. In section 4.16, clarified that ROM_ADDR[15:0] have internal 60KΩ pull-down resistor. Changes to Table 20 – Absolute Maximum Ratings: <ul style="list-style-type: none"> – Renamed parameters θ_{JA_XGA}, θ_{JA_SXGA}, θ_{JC_XGA} and θ_{JC_SXGA} to θ_{JA_5115}, θ_{JA_5125}, θ_{JC_5115} and θ_{JC_5125} and revised their values. – Added note (4) regarding the maximum case temperature. Changes to Table 21 – DC Characteristics: <ul style="list-style-type: none"> – Renamed parameters P_{5115} and P_{5125} and revised their values. – Revised the values of P_{LP} and I_{LP}. – Renamed parameters I_{5115}, $I_{5115_2.5_VDD}$, etc. – Added note (6). Removed the clock speed column from section 6 – Ordering Information and added the ordering information for gm5115-H and gm5125-H. Replaced occurrences of TMDS with DVI. Changed TCON_RCLK to TCON_ROWCLK in Figure 2 and in Table 7. Changed RCLK to ROWCLK in 4.13.2 and in Figure 24. 	October 2001

C5115-DAT-01G	<ul style="list-style-type: none">• Added section 4.15.3 - In-System-Programming (ISP) of FLASH ROM Devices.• Added section 4.15.4 - UART Interface.• Added section 4.15.5 - DDC2Bi Interface.• In sections 4.3.2 - ADC Characteristics and 4.4.1 - DVI Receiver Characteristics clarified that input formats with resolutions higher than that supported by the LCD panel are supported as recovery modes only.	March 2002
D5115-DAT-01H	<ul style="list-style-type: none">• Pins 143 ~ 146: changed xxx_SDDS or xxxx_SDDS to xxx_DDDS or xxxx_DDDS respectively• Pins 138 ~ 141: changed xxx_DDDS or xxxx_DDDS to xxx_SDDS or xxxx_SDDS respectively• Pins 147 ~ 148: changed xxx_DPLL to xxx_RPLL	June 2002

Related documents

Chip documents	
C5115-PBR-01	Preliminary Product Brief gm5115
C5125-PBR-01	Preliminary Product Brief gm5125
C5115-APB-01	gm5115 Product Family On-chip Microcontroller (OCM) Firmware Configurations
C5115-APB-02	gm5115 Product Family Support for Standard RGB (sRGB)
C5115-TOP-01	gm5115 Theory of Operation
C5115-DSL-01	gm5115 Register Listing
C5115-DSR-01	gm5115 TCON Programming Guide
C5115-DSR-02	gm5115 Input Processing Programming Guide
C5115-APN-03	gRGB Support in gm5115 Family Products
C5115-APN-04	gm5115 Family OCM User Manual
C5115-APN-06	Energy Spectrum Management (ESM) using gm5115 family OnPanel Controllers
C5115-APN-07	gm5115 Family IBIS Models
C5115-APN-08	gm5115 Monitor Standby Power Consumption
C5115-APN-10	gm5115 Enhanced Auto-Clock Configuration
Reference design documents	
B0124-GUD-01	5120RD2 Reference Design Users Guide
B0124-SCH-01	5120RD2 Reference Design Schematics
B0124-BOM-01	5120RD2 Reference Design Bill of Materials
B0124-DNF-01	5120RD2 Reference Design Layout Files
B0106-GUD-01	5115EV2 Board User Guide
B0106-SCH-01	5115EV2 Schematics
Firmware / tools documents	
B0092-SWT-01	gm5115 Product Family Firmware Theory of Operation for Full Custom Configuration
B0092-SUG-01	gm5115 Product Family Firmware User Guide for Full-Custom
B0092-PRN-01	gm5115 Product Family Firmware Release Notes for Full-Custom
C5115-SUG-01	gm5115 Product Family Firmware User Guide for Standalone
C5115-PRN-01	gm5115 Product Family Firmware Release Notes for Standalone
S0006-GUD-01	G-Probe Debug Software User Guide
S0014-GUD-01	G-Wizard Software User Guide

Table Of Contents

1. Overview	1
1.1 gm5115/25 System Design Example	1
1.2 gm5115/25 Features	2
2. gm5115/25 Pinout	3
3. gm5115/25 Pin List	4
4. Functional Description	10
4.1 Clock Generation	10
4.1.1 Using the Internal Oscillator with External Crystal	11
4.1.2 Using an External Clock Oscillator	13
4.1.3 Clock Synthesis	14
4.2 Hardware Reset	16
4.3 Analog to Digital Converter (ADC)	16
4.3.1 ADC Pin Connection	17
4.3.2 ADC Characteristics	17
4.3.3 Clock Recovery Circuit	18
4.3.4 Sampling Phase Adjustment	19
4.3.5 ADC Capture Window	19
4.4 Ultra-Reliable Digital Visual Receiver (DVI Rx)	20
4.4.1 DVI Receiver Characteristics	20
4.4.2 DVI Capture Window	21
4.4.3 High-Bandwidth Digital Content Protection (HDCP)	21
4.5 Test Pattern Generator (TPG)	21
4.6 Input Format Measurement (IFM)	22
4.6.1 HSYNC / VSYNC Delay	22
4.6.2 Horizontal and Vertical Measurement	23
4.6.3 Format Change Detection	23
4.6.4 Watchdog	24
4.6.5 Internal Odd/Even Field Detection	24
4.6.6 Input Pixel Measurement	24
4.6.7 Image Phase Measurement	24
4.6.8 Image Boundary Detection	25
4.6.9 Image Auto Balance	25
4.7 RealColor™ Digital Color Controls	25
4.7.1 RealColor™ Flesh tone Adjustment	25
4.7.2 Color Standardization and sRGB Support	26
4.8 High-Quality Scaling	26
4.8.1 Variable Zoom Scaling	26

4.8.2 Horizontal and Vertical Shrink	26
4.8.3 Moiré Cancellation	26
4.9 Bypass Options	27
4.10 Gamma Look-Up-Table (LUT)	27
4.11 Display Output Interface	27
4.11.1 Display Synchronization	27
4.11.2 Programming the Display Timing	27
4.11.3 Panel Power Sequencing (PPWR, PBIAS)	29
4.11.4 Output Dithering	30
4.12 Energy Spectrum Management (ESM)	30
4.13 Timing Controller (TCON)	31
4.13.1 Programmable Column Driver Interface	31
4.13.2 Programmable Row Driver Interface	33
4.14 OSD	35
4.14.1 On-Chip OSD SRAM	35
4.14.2 Color Look-up Table (LUT)	36
4.15 On-Chip Microcontroller (OCM)	37
4.15.1 Standalone Configuration	37
4.15.2 Full-Custom Configuration	38
4.15.3 In-System-Programming (ISP) of FLASH ROM Devices	39
4.15.4 UART Interface	39
4.15.5 DDC2Bi Interface	40
4.15.6 General Purpose Inputs and Outputs (GPIO)	40
4.16 Bootstrap Configuration Pins	41
4.17 Host Interface	42
4.17.1 Host Interface Command Format	42
4.17.2 2-wire Serial Protocol	42
4.18 Miscellaneous Functions	44
4.18.1 Power Down Operation	44
4.18.2 Pulse Width Modulation (PWM) Back Light Control	44
5. Electrical Specifications	45
5.1 Preliminary DC Characteristics	45
5.2 Preliminary AC Characteristics	47
6. Ordering Information	48
7. Mechanical Specifications	49

List Of Tables

Table 1.	Analog Input Port.....	4
Table 2.	DVI Input Port	5
Table 3.	RCLK PLL Pins.....	5
Table 4.	System Interface and GPIO Signals.....	6
Table 5.	Display Output Port	7
Table 6.	Parallel ROM Interface Port	8
Table 7.	TCON Output Port.....	8
Table 8.	Reserved Pins.....	8
Table 9.	Power Pins for ADC Sampling Clock DDS.....	9
Table 10.	Power Pins for Display Clock DDS.....	9
Table 11.	I/O Power and Ground Pins	9
Table 12.	Core Power and Ground Pins.....	9
Table 13.	TCLK Specification	14
Table 14.	Pin Connection for RGB Input with HSYNC/VSYNC	17
Table 15.	ADC Characteristics	18
Table 16.	DVI Receiver Characteristics.....	20
Table 17.	gm5115/25 GPIOs and Alternate Functions	41
Table 18.	Bootstrap Signals	41
Table 19.	Instruction Byte Map	42
Table 20.	Absolute Maximum Ratings	45
Table 21.	DC Characteristics	46
Table 22.	Maximum Speed of Operation.....	47
Table 23.	Display Timing and DCLK Adjustments	47
Table 24.	2-Wire Host Interface Port Timing.....	47

List Of Figures

Figure 1.	gm5115/25 System Design Example	1
Figure 2.	gm5115/25 Pin Out Diagram	3
Figure 3.	gm5115/25 Functional Block Diagram.....	10
Figure 4.	Using the Internal Oscillator with External Crystal.....	11
Figure 5.	Internal Oscillator Output	12
Figure 6.	Sources of Parasitic Capacitance	13
Figure 7.	Using an External Single-ended Clock Oscillator	14
Figure 8.	Internally Synthesized Clocks.....	15
Figure 9.	On-chip Clock Domains	16
Figure 10.	Example ADC Signal Terminations	17
Figure 11.	gm5115/25 Clock Recovery	18
Figure 12.	ADC Capture Window.....	19
Figure 13.	Some of gm5115/25 built-in test patterns.....	21
Figure 14.	Factory Calibration and Test Environment.....	22
Figure 15.	HSYNC Delay	23
Figure 16.	Active Data Crosses HSYNC Boundary.....	23
Figure 17.	ODD/EVEN Field Detection	24
Figure 18.	RealColor™ Digital Color Controls	25
Figure 19.	Display Windows and Timing	28
Figure 20.	Single Pixel Width Display Data	29
Figure 21.	Double Pixel Wide Display Data.....	29
Figure 22.	Panel Power Sequencing.....	30
Figure 23.	Column Driver Interface Timing	32
Figure 24.	Row Driver Interface Timing.....	34
Figure 25.	OSD Cell Map.....	36
Figure 26.	OCM Full-Custom and Standalone Configurations.....	37
Figure 27.	Programming OCM in Standalone Configuration	38
Figure 28.	Programming the OCM in Full-Custom Configuration.....	39
Figure 29.	2-Wire Protocol Data Transfer.....	43
Figure 30.	2-Wire Write Operations (0x1x & 0x2x).....	43
Figure 31.	2-Wire Read Operation (0xAx).....	44
Figure 32.	gm5115/25 208-pin PQFP Mechanical Drawing.....	49

1. OVERVIEW

The gm5115/25 is a graphics processing IC for Liquid Crystal Display (LCD) monitors at XGA/SXGA resolution. It provides all key IC functions required for image capture, processing and timing control for direct interface to the row and column drivers of the LCD panel. On-chip functions include a high-speed triple-ADC and PLL, Ultra-Reliable DVI™ receiver, a high quality zoom and shrink scaling engine, an on-screen display (OSD) controller, an on-chip microcontroller (OCM), and a programmable panel timing controller (TCON). With all these functions integrated onto a single device, the gm5115/25 eliminates the need for a printed circuit board (PCB) from the system along with the associated connectors and cables. Therefore, the gm5115/25 simplifies the design and reduces the cost of LCD monitors while maintaining a high-degree of flexibility and quality.

1.1 gm5115/25 System Design Example

Figure 1 below shows a typical dual interface LCD monitor system based on the gm5115/25. Designs based on the gm5115/25 have reduced system cost, simplified hardware and firmware design and increased reliability because only a minimal number of components are required in the system.

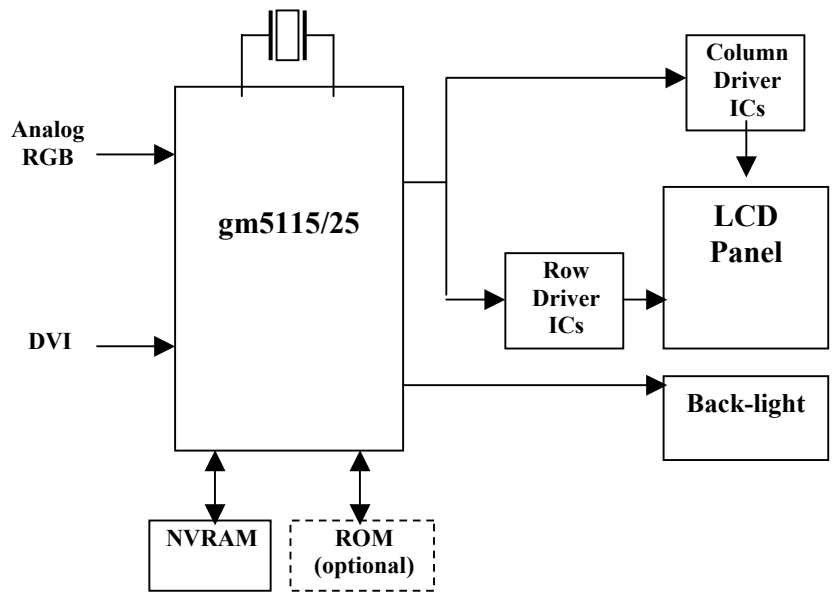

Figure 1. gm5115/25 System Design Example

1.2 gm5115/25 Features

FEATURES

- Zoom (from VGA) and shrink (from UXGA) scaling
- Integrated 8-bit triple-channel ADC / PLL
- Integrated Ultra-Reliable DVI 1.0-compliant receiver
- High-Bandwidth Digital Content Protection (HDCP)
- On-chip programmable OnPanel timing controller
- Embedded microcontroller with parallel ROM interface
- On-chip versatile OSD engine
- All system clocks synthesized from a single external crystal
- Programmable gamma correction (CLUT)
- RealColor controls provide sRGB compliance
- PWM back light intensity control
- 5 Volt tolerant inputs
- Low EMI and power saving features
- **High-Quality Advanced Scaling**
 - Fully programmable zoom ratios
 - High-quality shrink capability from UXGA resolution
 - Real Recovery™ function provides full color recovery image for refresh rates higher than those supported by the LCD panel
 - Moire cancellation
- **Analog RGB Input Port**
 - Supports up to 162.5MHz (SXGA 75Hz / UXGA 60Hz)
 - On-chip high-performance PLLs (only a single reference crystal required)
- **Auto-Configuration / Auto-Detection**
 - Input format detection
 - Phase and image positioning
- **Ultra-Reliable DVI Compliant Input Port**
 - Operating up to 165 MHz (up to UXGA 60Hz)
 - Direct connect to all DVI compliant digital transmitters
 - High-bandwidth Digital Content Protection (HDCP)
- **RealColor™ Technology**
 - Digital brightness and contrast controls
 - TV color controls including hue and saturation controls
 - Flesh-tone adjustment
 - Full color matrix allows end-users to experience the same colors as viewed on CRTs and other displays (e.g. sRGB compliance)
- **On-chip OSD Controller**
 - On-chip RAM for downloadable menus
 - 1, 2 and 4-bit per pixel character cells
 - Horizontal and vertical stretch of OSD menus
 - Blinking, transparency and blending
- **On-chip Microcontroller**
 - Requires no external micro-controller
 - External parallel ROM interface allows firmware customization with little additional cost
 - 23 general-purpose inputs/outputs (GPIOs) available for managing system devices (keypad, back-light, NVRAM, etc)
 - Industry-standard firmware embedded on-chip, requires no external ROM (configuration settings stored in NVRAM)
- **Built-in OnPanel Timing Controller**
 - Eliminates the need for an external panel timing controller (TCON) device, thereby reducing system cost
 - Direct connect to commercial row/column driver ICs (supports dual-bus / dual-port and dual-bus / single-port)
 - Low EMI and power saving features include frame, line and in-line inversion, blanking, data staggering and slew rate control.
- **Programmable Output Format**
 - Single / double wide up to XGA/SXGA 75Hz output
 - Pin swap, odd / even swap and red / blue group swap of RGB outputs for flexibility in board layout
 - Support for 8 or 6-bit panels (with high-quality dithering)
- **Highly Integrated System-on-a-Chip Reduces Component Count for *Highly Cost Effective Solution***
- ***Standalone* operation requires no external ROM and no firmware development for *Fast Time to Market***
- **Pin and register compatible *OnPanel Family*:**
 - gm5115/gm5125 Dual-Interface XGA/SXGA
 - gm3115/gm3125 Digital-Interface XGA/SXGA
 - gm2115/gm2125 Analog-Interface XGA/SXGA

2. GM5115/25 PINOUT

The gm5115/25 is available in a 208-pin Plastic Quad Flat Pack (PQFP) package. Figure 2 provides the pin locations for all signals.

	208	GPIO18			156	GND1_ADC
	207	GPIO19			155	VDD1_ADC_2.5
	206	GPIO20			154	GND2_ADC
	205	GPIO16/HFSn			153	VDD2_ADC_2.5
	204	GPIO22/HCLK			152	TCLK
	203	CVDD_2.5			151	XTAL
	202	CVSS			150	AVDD_RPLL
	201	CLKOUT			149	AVSS_RPLL
	200	NC			148	VDD_RPLL
	199	VDD_RXPLL_2.5			147	VSS_RPLL
	198	AGND_RXPLL			146	AVDD_DDDS
	197	AGND_RXC			145	AVSS_DDDS
	196	AVDD_RXC			144	VDD_DDDS
	195	RXC+			143	VSS_DDDS
	194	RXC-			142	N/C
	193	AVDD_RX0			141	AVDD_SDDS
	192	RX0-			140	AVSS_SDDS
	191	RX0+			139	VDD_SDDS
	190	AGND_RX0			138	VSS_SDDS
	189	GND_RX0			137	HSYNC
	188	VDD_RX0_2.5			136	VSYN
	187	AVDD_RX1			135	CVSS
	186	RX1-			134	CVDD_2.5
	185	RX1+			133	CVSS
	184	AGND_RX1			132	Reserved
	183	GND_RX1			131	Reserved
	182	VDD_RX1_2.5			130	RVSS
	181	AVDD_RX2			129	RVDD
	180	RX2-			128	TCON_ROE
	179	RX2+			127	TCON_ROWCLK
	178	AGND_RX2			126	TCON_RSP3
	177	GND_RX2			125	TCON_RSP2
	176	VDD_RX2_2.5			124	TCON_EINV
	175	AGND_IMB			123	TCON_EPOL
	174	RXT1			122	TCON_ESP
	173	AVDD_IMB			121	TCON_OINV
	172	AVDD_RED			120	TCON_OPOL
	171	RED+			119	TCON_OSP
	170	RED-			118	DCLK/TCON_OCLK
	169	AGND_RED			117	DVS/TCON_FSYNC
	168	AVDD_GREEN			116	DHS/TCON_LP
	167	GREEN+			115	DEN/TCON_ECLK
	166	GREEN-			114	PBIAS
	165	AGND_GREEN			113	PPWR
	164	AVDD_BLUE			112	RVSS
	163	BLUE+			111	RVDD
	162	BLUE-			110	PD47/OB7
	161	AGND_BLUE			109	PD46/OB6
	160	AVDD_ADC			108	PD45/OB5
	159	ADC_TEST			107	PD44/OB4
	158	AGND_ADC			106	PD43/OB3
	157	SGND_ADC			105	PD42/OB2
	53	RVDD			54	RVSS
	54	RVSS			55	PD0/ER0
	55	PD0/ER0			56	PD1/ER1
	56	PD1/ER1			57	PD2/ER2
	57	PD2/ER2			58	PD3/ER3
	58	PD3/ER3			59	PD4/ER4
	59	PD4/ER4			60	PD5/ER5
	60	PD5/ER5			61	PD6/ER6
	61	PD6/ER6			62	PD7/ER7
	62	PD7/ER7			63	PD8/EG0
	63	PD8/EG0			64	PD9/EG1
	64	PD9/EG1			65	PD10/EG2
	65	PD10/EG2			66	PD11/EG3
	66	PD11/EG3			67	RVDD
	67	RVDD			68	RVSS
	68	RVSS			69	PD12/EG4
	69	PD12/EG4			70	PD13/EG5
	70	PD13/EG5			71	PD14/EG6
	71	PD14/EG6			72	PD15/EG7
	72	PD15/EG7			73	PD16/EB0
	73	PD16/EB0			74	PD17/EB1
	74	PD17/EB1			75	PD18/EB2
	75	PD18/EB2			76	PD19/EB3
	76	PD19/EB3			77	PD20/EB4
	77	PD20/EB4			78	PD21/EB5
	78	PD21/EB5			79	PD22/EB6
	79	PD22/EB6			80	PD23/EB7
	80	PD23/EB7			81	RVDD
	81	RVDD			82	RVSS
	82	RVSS			83	PD24/OR0
	83	PD24/OR0			84	PD25/OR1
	84	PD25/OR1			85	PD26/OR2
	85	PD26/OR2			86	PD27/OR3
	86	PD27/OR3			87	PD28/OR4
	87	PD28/OR4			88	CVDD_2.5
	88	CVDD_2.5			89	CVSS
	89	CVSS			90	PD29/OR5
	90	PD29/OR5			91	PD30/OR6
	91	PD30/OR6			92	PD31/OR7
	92	PD31/OR7			93	PD32/OG0
	93	PD32/OG0			94	PD33/OG1
	94	PD33/OG1			95	PD34/OG2
	95	PD34/OG2			96	PD35/OG3
	96	PD35/OG3			97	RVDD
	97	RVDD			98	RVSS
	98	RVSS			99	PD36/OG4
	99	PD36/OG4			100	PD37/OG5
	100	PD37/OG5			101	PD38/OG6
	101	PD38/OG6			102	PD39/OG7
	102	PD39/OG7			103	PD40/OB0
	103	PD40/OB0			104	PD41/OB1
	104	PD41/OB1				

Figure 2. gm5115/25 Pin Out Diagram

3. GM5115/25 PIN LIST

I/O Legend: **A** = Analog, **I** = Input, **O** = Output, **P** = Power, **G**= Ground

Table 1. Analog Input Port

Pin Name	No.	I/O	Description
AVDD_RED	172	AP	Analog power (3.3V) for the red channel. Must be bypassed with decoupling capacitor to AGND_RED pin on system board (as close as possible to the pin).
RED+	171	AI	Positive analog input for Red channel.
RED-	170	AI	Negative analog input for Red channel.
AGND_RED	169	AG	Analog ground for the red channel. Must be directly connected to the analog system ground plane.
AVDD_GREEN	168	AP	Analog power (3.3V) for the green channel. Must be bypassed with decoupling capacitor to AGND_GREEN pin on system board (as close as possible to the pin).
GREEN+	167	AI	Positive analog input for Green channel.
GREEN-	166	AI	Negative analog input for Green channel.
AGND_GREEN	165	AG	Analog ground for the green channel. Must be directly connected to the analog system ground plane.
AVDD_BLUE	164	AP	Analog power (3.3V) for the blue channel. Must be bypassed with decoupling capacitor to AGND_BLUE pin on system board (as close as possible to the pin).
BLUE+	163	AI	Positive analog input for Blue channel.
BLUE-	162	AI	Negative analog input for Blue channel.
AGND_BLUE	161	AG	Analog ground for the blue channel. Must be directly connected to the analog system ground plane.
AVDD_ADC	160	AP	Analog power (3.3V) for ADC analog blocks that are shared by all three channels. Includes band gap reference, master biasing and full-scale adjust. Must be bypassed with decoupling capacitor to AGND_ADC pin on system board (as close as possible to the pin).
ADC_TEST	159	AO	Analog test output for ADC. Do not connect.
AGND_ADC	158	AG	Analog ground for ADC analog blocks that are shared by all three channels. Includes band gap reference, master biasing and full-scale adjust. Must be directly connected to analog system ground plane.
SGND_ADC	157	AG	Dedicated pad for substrate guard ring that protects the ADC reference system. Must be directly connected to the analog system ground plane.
GND1_ADC	156	G	Digital GND for ADC clocking circuit. Must be directly connected to the digital system ground plane.
VDD1_ADC_2.5	155	P	Digital power (2.5V) for ADC encoding logic. Must be bypassed with decoupling capacitor to GND1_ADC pin on system board (as close as possible to the pin).
GND2_ADC	154	G	Digital GND for ADC clocking circuit. Must be directly connected to the digital system ground plane.
VDD2_ADC_2.5	153	P	Digital power (2.5V) for ADC encoding logic. Must be bypassed with decoupling capacitor to GND2_ADC pin on system board (as close as possible to the pin).
HSYNC	137	I	ADC input horizontal sync input. [Input, Schmitt trigger (400mV typical hysteresis), 5V-tolerant]
VSYNC	136	I	ADC input vertical sync input. [Input, Schmitt trigger (400mV typical hysteresis), 5V-tolerant]

Table 2. DVI Input Port

Pin Name	No	I/O	Description
AVDD_IMB	173	AP	Analog VDD (3.3V) for internal biasing circuits. Must be bypassed with decoupling capacitors (as close as possible to the pin).
REXT	174	AI	External reference resistor. An external 1Kohm (1%) resistor should be connected from this pin to AVDD_IMB pin.
AGND_IMB	175	AG	Analog GND for internal biasing circuits. Must be connected directly to the ground plane.
VDD_RX2_2.5	176	P	VDD (2.5V) for DVI input pair 2 logic circuits. Must be bypassed with decoupling capacitor to GND_RX2 pin (as close as possible to the pin).
GND_RX2	177	G	GND for DVI input pair 2 logic circuits. Must be connected directly to the ground plane.
AGND_RX2	178	AG	Analog GND for DVI input pair 2 input buffer. Must be connected directly to the analog ground plane.
RX2+	179	AI	DVI input pair 2
RX2-	180	AI	DVI input pair 2
AVDD_RX2	181	AP	Analog VDD (3.3V) for DVI input pair 2 input buffer. Must be bypassed with decoupling capacitor to AGND_RX2 pin (as close as possible to the pin).
VDD_RX1_2.5	182	P	VDD (2.5V) for DVI input pair 1 logic circuits. Must be bypassed with decoupling capacitor to GND_RX1 pin (as close as possible to the pin).
GND_RX1	183	G	GND for DVI input pair 1 input buffer. Must be connected directly to the analog ground plane.
AGND_RX1	184	AG	Analog GND for DVI input pair 1 input buffer. Must be connected directly to the analog ground plane.
RX1+	185	AI	DVI input pair 1
RX1-	186	AI	DVI input pair 1
AVDD_RX1	187	AP	Analog VDD (3.3V) for DVI input pair 1 input buffer. Must be bypassed with decoupling capacitor to AGND_RX1 pin (as close as possible to the pin).
VDD_RX0_2.5	188	P	VDD (2.5V) for DVI input pair 0 logic circuits. Must be bypassed with decoupling capacitor to GND_RX0 pin (as close as possible to the pin).
GND_RX0	189	G	GND for DVI input pair 0 logic circuits. Must be connected directly to the ground plane.
AGND_RX0	190	AG	Analog GND for DVI input pair 0 input buffer. Must be connected directly to the analog ground plane.
RX0+	191	AI	DVI input pair 0
RX0-	192	AI	DVI input pair 0
AVDD_RX0	193	AP	Analog VDD (3.3V) for DVI input pair 0 input buffer. Must be bypassed with decoupling capacitor to AGND_RX0 pin (as close as possible to the pin).
RXC+	194	AI	DVI input clock pair
RXC-	195	AI	DVI input clock pair
AVDD_RXC	196	AP	Analog VDD (3.3V) for DVI input clock pair input buffer. Must be bypassed with 100pF capacitor to AGND_RXC pin (as close as possible to the pin).
AGND_RXC	197	AG	Analog GND for DVI input clock pair input buffer. Must be connected directly to the analog ground plane.
GND_RXPLL	198	G	Digital GND for the DVI receiver internal PLL. Must be connected directly to the system ground plane.
VDD_RXPLL_2.5	199	AP	Analog VDD (2.5V) for the DVI receiver internal PLL. Must be bypassed with a decoupling capacitor to AGND_RXPLL pin (as close as possible to the pin).
CLKOUT	201	AO	For test purposes only. Do not connect.

Table 3. RCLK PLL Pins

Pin Name	No	I/O	Description
AVDD_RPLL	150	AP	Analog power for the Reference DDS PLL. Connect to 3.3V supply. Must be bypassed with a 0.1uF capacitor to pin AVSS_RPLL (as close to the pin as possible).
AVSS_RPLL	149	AG	Analog ground for the Reference DDS PLL. Must be directly connected to the analog system ground plane.
TCLK	152	AI	Reference clock (TCLK) from the 14.3MHz crystal oscillator (see Figure 4), or from single-ended CMOS/TTL clock oscillator (see Figure 7). This is a 5V-tolerant input. See Table 14.
XTAL	151	AO	Crystal oscillator output.
VDD_RPLL	148	P	Digital power for RCLK PLL. Connect to 3.3V supply.
VSS_RPLL	147	G	Digital ground for RCLK PLL.

Table 4. System Interface and GPIO Signals

Pin Name	No	I/O	Description
RESETn	5	I	Active-low hardware reset signal. The reset signal must be held low for at least 1 μ S. [Input, Schmitt trigger (400mV typical hysteresis), 5V-tolerant]
GPIO0/PWM0	40	IO	General-purpose input/output signal or PWM0. Open drain option via register setting. [Bi-directional, Schmitt trigger (400mV typical hysteresis), 5V-tolerant]
GPIO1/PWM1	41	IO	General-purpose input/output signal or PWM1. Open drain option via register setting. [Bi-directional, Schmitt trigger (400mV typical hysteresis), 5V-tolerant]
GPIO2/PWM2	42	IO	General-purpose input/output signal or PWM2. Open drain option via register setting. [Bi-directional, Schmitt trigger (400mV typical hysteresis), 5V-tolerant]
GPIO3/TIMER1	43	IO	General-purpose input/output signal. Open drain option via register setting. This pin is also connected to Timer 1 clock input of the OCM. [Bi-directional, Schmitt trigger (400mV typical hysteresis), 5V-tolerant]
GPIO4/UART_DI	44	IO	General-purpose input/output signal. Open drain option via register setting. This pin is also connected to the OCM UART data input signal by programming an OCM register. [Bi-directional, Schmitt trigger (400mV typical hysteresis), 5V-tolerant]
GPIO5/UART_DO	45	IO	General-purpose input/output signal. Open drain option via register setting. This pin is also connected to the OCM UART data output signal by programming an OCM register. [Bi-directional, Schmitt trigger (400mV typical hysteresis), 5V-tolerant]
GPIO6/TCON_SHC	46	IO	General-purpose input/output signal. [Bi-directional, Schmitt trigger (400mV typical hysteresis), 5V-tolerant]
GPIO7/TCON_TDIV	47	IO	General-purpose input/output signal. [Bi-directional, Schmitt trigger (400mV typical hysteresis), 5V-tolerant]
GPIO8/IRQIn	39	IO	General-purpose input/output signal. This is also active-low interrupt input to OCM and is directly wired to OCM int_0n. [Bi-directional, Schmitt trigger (400mV typical hysteresis), 5V-tolerant]
GPIO9/TCON_ROE2	48	IO	General-purpose input/output signal. Open drain option via register setting. This pin can also function as TCON signal ROE2. [Bi-directional, Schmitt trigger (400mV typical hysteresis), 5V-tolerant]
GPIO10/TCON_ROE3	49	IO	General-purpose input/output signal. Open drain option via register setting. This pin can also function as TCON signal ROE3. [Bi-directional, Schmitt trigger (400mV typical hysteresis), 5V-tolerant]
GPIO11/ROM_WEn	50	IO	General-purpose input/output signal, or ROM write enable if a programmable FLASH device is used. Open drain option via register setting. [Bi-directional Input, Schmitt trigger (400mV typical hysteresis), 5V-tolerant]
GPIO12/NVRAM_SDA GPIO13/NVRAM_SCL	51 52	IO IO	General-purpose input/output signals, or 2-wire master serial interface to NVRAM in standalone mode. Open drain option via register setting. [Bi-directional Input, Schmitt trigger (400mV typical hysteresis), 5V-tolerant]
GPIO14/DDC_SCL GPIO15/DDC_SDA	6 7	IO IO	DDC Interface for DVI-HDCP communication. This is 5V-tolerant SCL pin.
GPIO16/HFSn	205	IO	General-purpose input/output signal when host port is disabled, or data signal for 2-wire serial host interface. [Bi-directional, Schmitt trigger (400mV typical hysteresis), slew rate limited, 5V tolerant]
GPIO17 GPIO18 GPIO19 GPIO20	1 208 207 206	IO IO IO IO	General-purpose input/output signals. [Bi-directional, Schmitt trigger (400mV typical hysteresis), 5V-tolerant]
GPIO21/IRQn	4	IO	General-purpose input/output signal when host port is disabled, or active-low and open-drain interrupt output pin. [Bi-directional, 5V-tolerant]
GPIO22/HCLK	204	IO	General-purpose input/output signal when host port is disabled, or clock for 2-wire serial host interface. [Bi-directional, Schmitt trigger (400mV typical hysteresis), 5V-tolerant]

Table 5. Display Output Port

Pin Name	No	I/O	Description
DCLK/TCON_OCLK	118	O	Panel output clock or TCON Odd Column Driver Bus Clock. [Tri-state output, Programmable Drive]
DVS/TCON_FSYNC	117	O	Panel Vertical Sync or TCON Frame Synchronization. [Tri-state output, Programmable Drive]
DHS/TCON_LP	116	O	Panel Horizontal Sync or TCON Load Pulse. [Tri-state output, Programmable Drive]
DEN/TCON_ECLK	115	O	Panel Display Enable, which frames the output background window, or TCON Even Column Driver Bus Clock. [Tri-state output, Programmable Drive]
PBIAS	114	O	Panel Bias Control (back light enable) [Tri-state output, Programmable Drive]
PPWR	113	O	Panel Power Control [Tri-state output, Programmable Drive]
PD47	110	O	Panel or TCON output data. [Tri-state output, Programmable Drive]
PD46	109	O	
PD45	108	O	
PD44	107	O	
PD43	106	O	
PD42	105	O	
PD41	104	O	
PD40	103	O	
PD39	102	O	
PD38	101	O	
PD37	100	O	
PD36	99	O	
PD35	96	O	
PD34	95	O	
PD33	94	O	
PD32	93	O	
PD31	92	O	
PD30	91	O	
PD29	90	O	
PD28	87	O	
PD27	86	O	
PD26	85	O	
PD25	84	O	
PD24	83	O	
PD23	80	O	
PD22	79	O	
PD21	78	O	
PD20	77	O	
PD19	76	O	
PD18	75	O	
PD17	74	O	
PD16	73	O	
PD15	72	O	
PD14	71	O	
PD13	70	O	
PD12	69	O	
PD11	66	O	
PD10	65	O	
PD9	64	O	
PD8	63	O	
PD7	62	O	
PD6	61	O	
PD5	60	O	
PD4	59	O	
PD3	58	O	
PD2	57	O	
PD1	56	O	
PD0	55	O	

Table 6. Parallel ROM Interface Port

Pin Name	No	I/O	Description
ROM_ADDR15	8	IO	ROM address output. These pins also serve as 5V-tolerant bootstrap inputs on power up.
ROM_ADDR14	9	IO	
ROM_ADDR13	10	IO	
ROM_ADDR12	11	IO	
ROM_ADDR11	12	IO	
ROM_ADDR10	13	IO	
ROM_ADDR9	14	IO	
ROM_ADDR8	15	IO	
ROM_ADDR7	16	IO	
ROM_ADDR6	17	IO	
ROM_ADDR5	18	IO	
ROM_ADDR4	19	IO	
ROM_ADDR3	22	IO	
ROM_ADDR2	23	IO	
ROM_ADDR1	24	IO	
ROM_ADDR0	25	IO	
ROM_DATA7	28	I	5V-tolerant external PROM data input
ROM_DATA6	29	I	
ROM_DATA5	30	I	
ROM_DATA4	31	I	
ROM_DATA3	32	I	
ROM_DATA2	33	I	
ROM_DATA1	34	I	
ROM_DATA0	35	I	
ROM_Oen	36	O	External PROM data Output Enable

Table 7. TCON Output Port

Pin Name	No	I/O	Description
TCON_OSP	119	O	Odd Starting Pulse
TCON_OPOL	120	O	Odd Polarity
TCON_OINV	121	O	Odd Data Transmission Inversion
TCON_ESP	122	O	Even Starting Pulse
TCON_EPOL	123	O	Even Polarity
TCON_EINV	124	O	Even Data Transmission Inversion
TCON_RSP2	125	O	Row Starting Pulse for 2-Voltage Row Driver
TCON_RSP3	126	O	Row Starting Pulse for 3-Voltage Row Driver
TCON_ROWCLK	127	O	Row Shift Clock
TCON_ROE	128	O	Row Output Enable

Table 8. Reserved Pins

Pin Name	No	I/O	Description
Reserved	131	I	Tie to GND.
Reserved	132	I	Tie to GND.
N/C	142	O	No connect.
N/C	200	O	No connect.

Note that VDD pins having "_2.5" in their names should be connected to 2.5V power supplies. All other VDD pins should be connected to 3.3V power supplies.

Table 9. Power Pins for ADC Sampling Clock DDS

Pin Name	No	I/O	Description
AVDD_DDDS	146	AP	Analog power for the Destination DDS. Connect to 3.3V supply. Must be bypassed with a 0.1uF capacitor to AVSS_DDDS pin (as close to the pin as possible).
AVSS_DDDS	145	AG	Analog ground for the Destination DDS. Must be directly connected to the analog system ground.
VDD_DDDS	144	P	Digital power for the Destination DDS. Connect to 3.3V supply.
VSS_DDDS	143	G	Digital ground for the Destination DDS.

Table 10. Power Pins for Display Clock DDS

Pin Name	No	I/O	Description
AVDD_SDDS	141	AP	Analog power for Source DDS. Connect to 3.3V supply. Must be bypassed with a 0.1uF capacitor to AVSS_SDDS pin (as close to the pin as possible).
AVSS_SDDS	140	AG	Analog ground for Source DDS. Must be directly connected to the analog system ground plane.
VDD_SDDS	139	P	Digital power for the Source DDS. Connect to 3.3V supply.
VSS_SDDS	138	G	Digital ground for the Source DDS.

Table 11. I/O Power and Ground Pins

Pin Name	No	I/O	Description
RVDD	2	P	Connect to 3.3V supply. Must be bypassed with a 0.1uF capacitor to RVSS (as close to the pin as possible).
	20	P	
	37	P	
	53	P	
	67	P	
	81	P	
	97	P	
	111	P	
	129	P	
RVSS	3	G	Connect to digital ground.
	21	G	
	38	G	
	54	G	
	68	G	
	82	G	
	98	G	
	112	G	
	130	G	

Table 12. Core Power and Ground Pins

Pin Name	No	I/O	Description
CVDD_2.5	26	P	Connect to 2.5V supply. Must be bypassed with a 0.1uF capacitor to CVSS (as close to the pin as possible).
	88	P	
	134	P	
	203	P	
CVSS	27	G	Connect to digital ground.
	89	G	
	133	G	
	135	G	
	202	G	

Note: "AP" indicates a power supply that is analog in nature and does not have large switching currents. These should be isolated from other digital supplies that do have large switching currents.

4. FUNCTIONAL DESCRIPTION

A functional block diagram is illustrated below. Each of the functional units shown is described in the following sections.

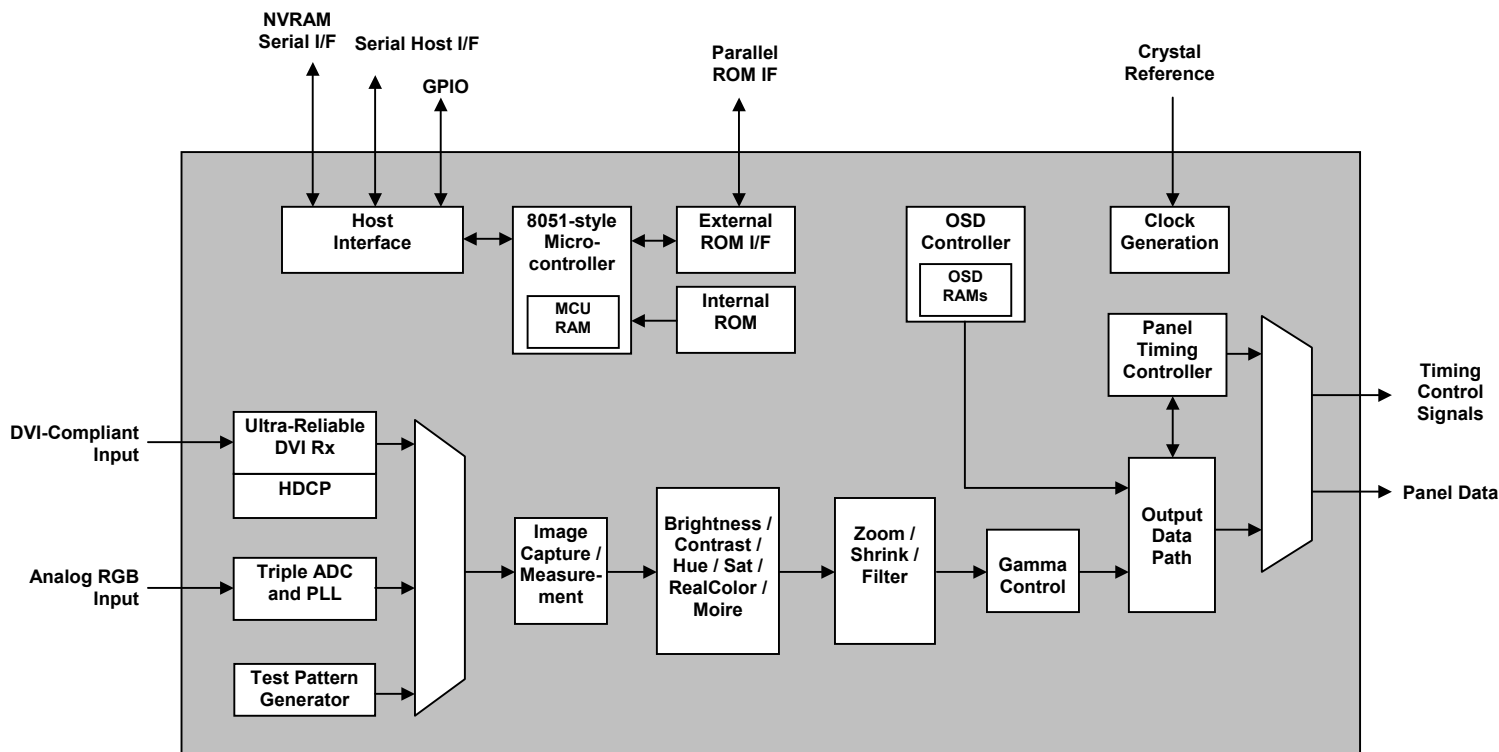

Figure 3. gm5115/25 Functional Block Diagram

4.1 Clock Generation

The gm5115/25 features three clock inputs. All additional clocks are internal clocks derived from one or more of these:

1. Crystal Input Clock (TCLK and XTAL). This is the input pair to an internal crystal oscillator and corresponding logic. A 14.3 MHz TV crystal is recommended. Other crystal frequencies may be used, but require custom programming. This is illustrated in Figure 4 below. Alternatively, a single-ended TTL/CMOS clock oscillator can be driven into the TCLK pin (leave XTAL as N/C in this case). This is illustrated in Figure 7 below. This option is selected by connecting a 10KΩ pull-up to ROM_ADDR13 (refer to Table 18). See also Table 14.
2. DVI Differential Input Clock (RC+ and RC-)
3. Host Interface Transfer Clock (HCLK)

The gm5115 TCLK oscillator circuitry is a custom designed circuit to support the use of an external oscillator or a crystal resonator to generate a reference frequency source for the gm5115 device.

4.1.1 Using the Internal Oscillator with External Crystal

The first option for providing a clock reference is to use the internal oscillator with an external crystal. The oscillator circuit is designed to provide a very low jitter and very low harmonic clock to the internal circuitry of the gm5115. An Automatic Gain Control (AGC) is used to insure startup and operation over a wide range of conditions. The oscillator circuit also minimizes the overdrive of the crystal, which reduces the aging of the crystal.

When the gm5115/25 is in reset, the state of the ROM_ADDR13 pin (pin number 10) is sampled. If the pin is left unconnected (internal pull-down) then internal oscillator is enabled. In this mode a crystal resonator is connected between TCLK (pin 152) and the XTAL (pin 151) with the appropriately sized loading capacitors C_{L1} and C_{L2} . The size of C_{L1} and C_{L2} are determined from the crystal manufacturer’s specification and by compensating for the parasitic capacitance of the gm5115/25 device and the printed circuit board traces. The loading capacitors are terminated to the analog VDD power supply. This connection increases the power supply rejection ratio when compared to terminating the loading capacitors to ground.

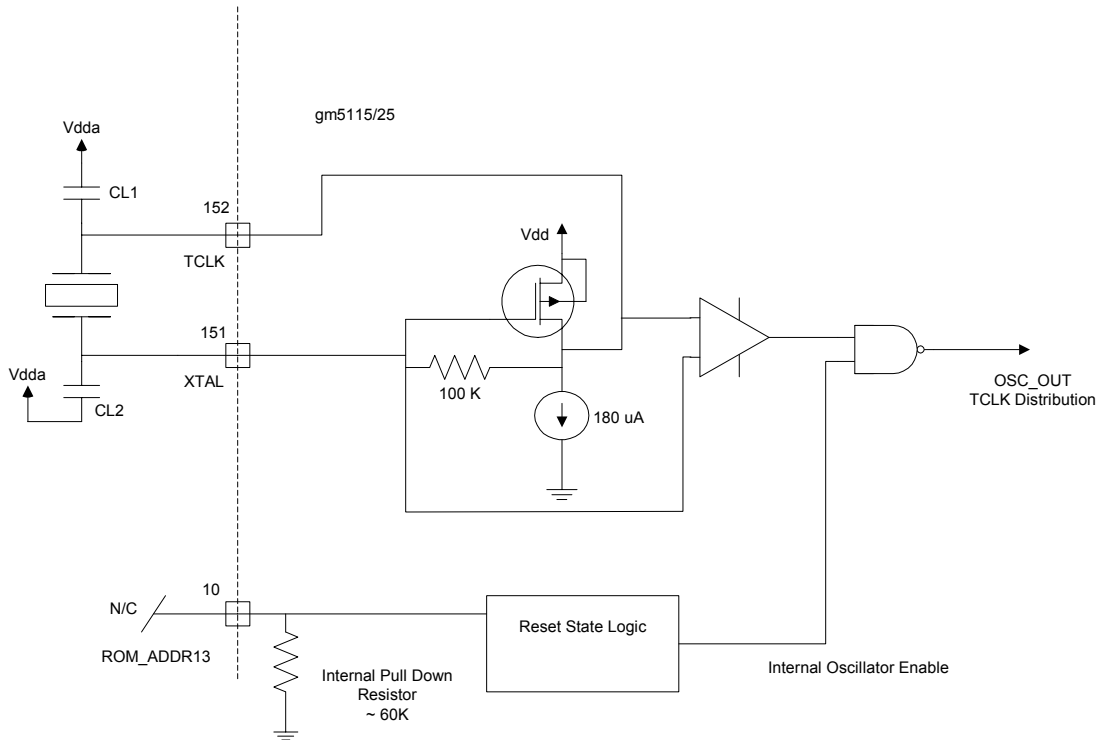

Figure 4. Using the Internal Oscillator with External Crystal

The TCLK oscillator uses a Pierce Oscillator circuit. The output of the oscillator circuit, measured at the TCLK pin, is an approximate sine wave with a bias of about 2 volts above ground (see Figure 5). The peak-to-peak voltage of the output can range from 250 mV to 1000 mV depending on the specific characteristics of the crystal and variation in the oscillator characteristics. The output of the oscillator is connected to a comparator that converts the sine wave to a square wave. The comparator requires a minimum signal level of about 50-mV peak to peak to function correctly. The output of the comparator is buffered and then distributed to the gm5115/25 circuits.

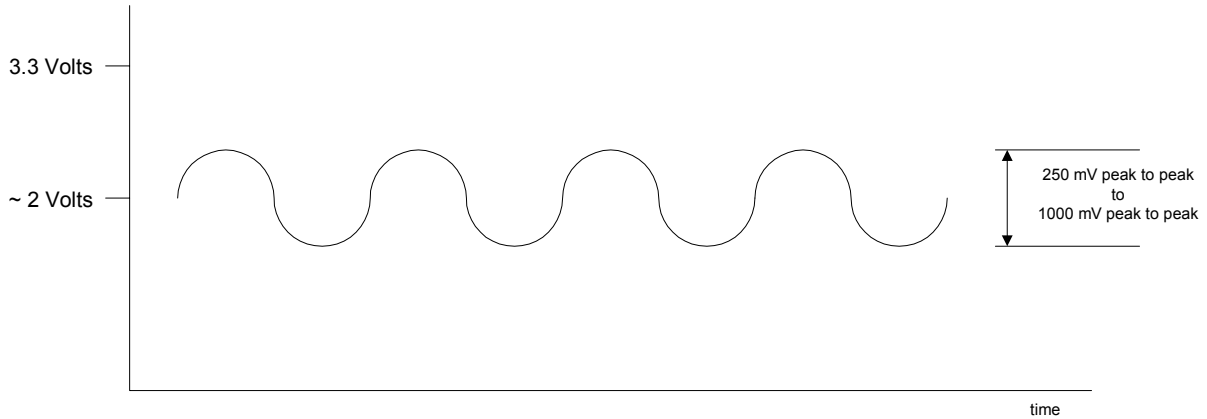

Figure 5. Internal Oscillator Output

One of the design parameters that must be given some consideration is the value of the loading capacitors used with the crystal as shown in Figure 6. The loading capacitance (C_{load}) on the crystal is the combination of C_{L1} and C_{L2} and is calculated by $C_{load} = ((C_{L1} * C_{L2}) / (C_{L1} + C_{L2})) + C_{shunt}$. The shunt capacitance C_{shunt} is the effective capacitance between the XTAL and TCLK pins. For the gm5115/25 this is approximately 9 pF. C_{L1} and C_{L2} are a parallel combination of the external loading capacitors (C_{ex}), the PCB board capacitance (C_{pcb}), the pin capacitance (C_{pin}), the pad capacitance (C_{pad}), and the ESD protection capacitance (C_{esd}). The capacitances are symmetrical so that $C_{L1} = C_{L2} = C_{ex} + C_{PCB} + C_{pin} + C_{pad} + C_{ESD}$. The correct value of C_{ex} must be calculated based on the values of the load capacitances. Approximate values are provided in Figure 6.

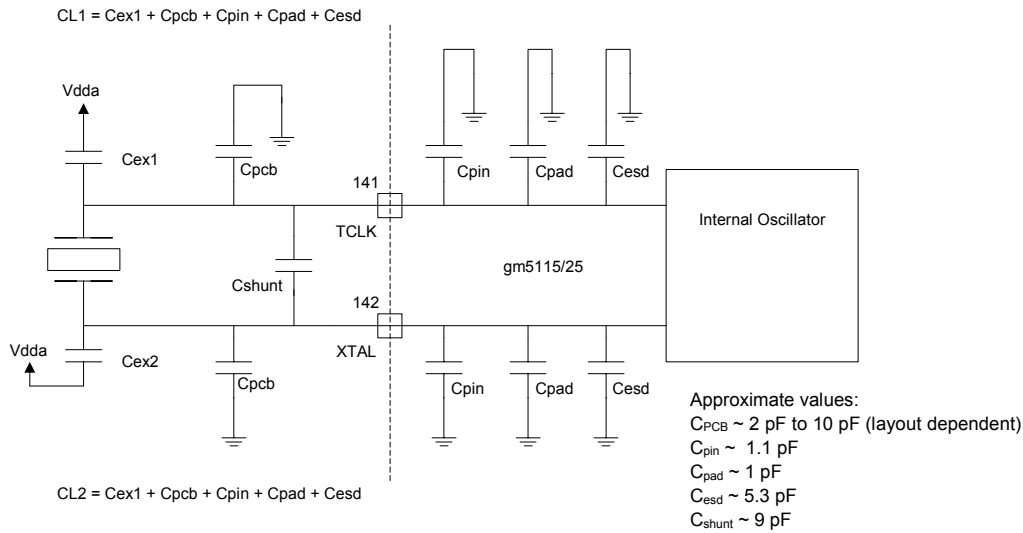

Figure 6. Sources of Parasitic Capacitance

Some attention must be given to the details of the oscillator circuit when used with a crystal resonator. The PCB traces should be as short as possible. The value of C_{load} that is specified by the manufacturer should not be exceeded because of potential start up problems with the oscillator. Additionally, the crystal should be a parallel resonate-cut and the value of the equivalent series resistance must be less than 90 Ohms.

4.1.2 Using an External Clock Oscillator

Another option for providing the reference clock is to use a single-ended external clock oscillator. When the gm5115/25 is in reset, the state of the ROM_ADDR13 (pin 10) is sampled. If ROM_ADDR13 is pulled high by connecting to VDD through a pull-up resistor (15KΩ recommended, 15KΩ maximum) then external oscillator mode is enabled. In this mode the internal oscillator circuit is disabled and the external oscillator signal that is connected to the TCLK pin (pin number 152) is routed to an internal clock buffer. This is illustrated in Figure 7.

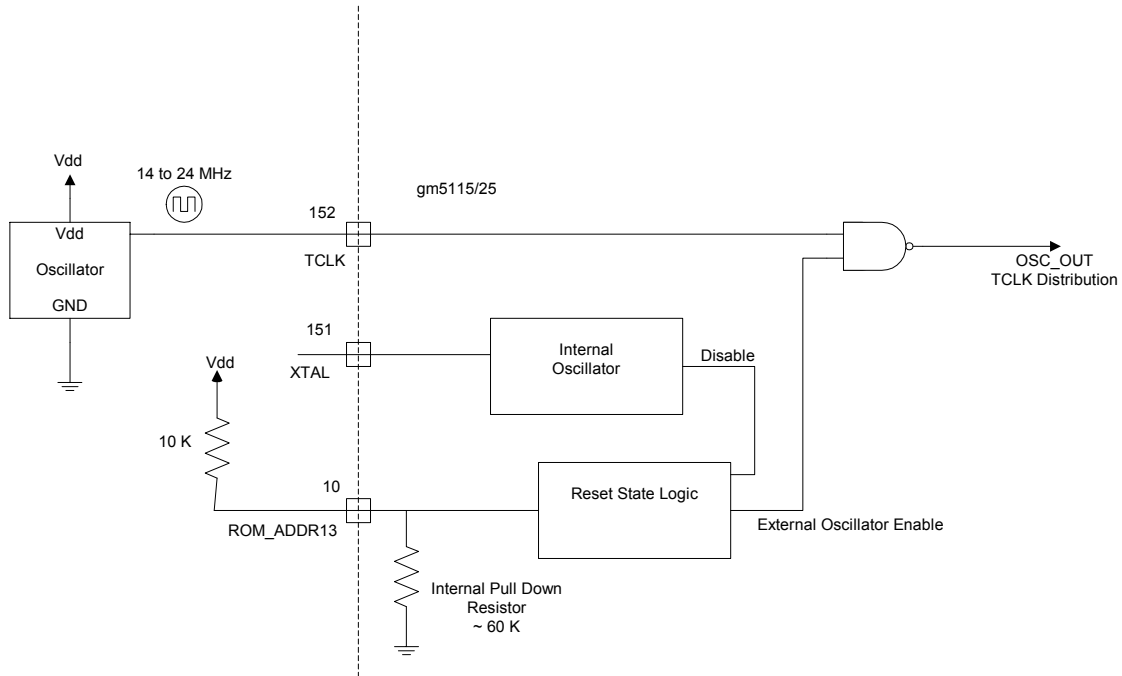

Figure 7. Using an External Single-ended Clock Oscillator

Frequency	14 to 24 MHz
Jitter Tolerance	250 ps
Rise Time (10% to 90%)	5 ns
Maximum Duty Cycle	40-60

Table 13. TCLK Specification

4.1.3 Clock Synthesis

The gm5115/25 synthesizes all additional clocks internally as illustrated in Figure 8 below. The synthesized clocks are as follows:

1. Main Timing Clock (TCLK) is the output of the chip internal crystal oscillator. TCLK is derived from the TCLK/XTAL pad input.
2. Reference Clock (RCLK) synthesized by RCLK PLL (RPLL) using TCLK as the reference.
3. DVI Input Clock (DVI_CLK) synthesized by DVI receiver PLL using RC+/RC- pair as the reference.
4. Input Source Clock (SCLK) synthesized by Source DDS (SDDS) PLL using input HSYNC as the reference. The SDDS internal digital logic is driven by RCLK.
5. Display Clock (DCLK) synthesized by Destination DDS (DDDS) PLL using IP_CLK as the reference. The DDDS internal digital logic is driven by RCLK.

6. Half Reference Clock (RCLK/2) is the RCLK (see 2, above) divided by 2. Used as OCM_CLK domain driver.
7. Quarter Reference Clock (RCLK/4) is the RCLK (see 2, above) divided by 4. Used as alternative clock (faster than TCLK) to drive IFM.
8. ADC Output Clock (SENSE_ACLK) is a delay-adjusted ADC sampling clock, ACLK. ACLK is derived from SCLK.

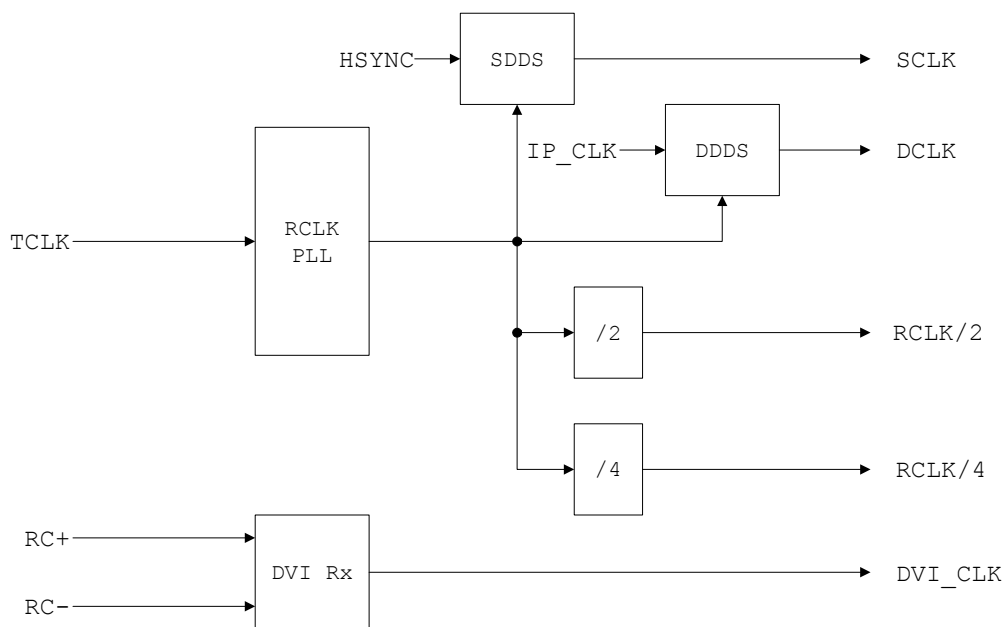

Figure 8. Internally Synthesized Clocks

The on-chip clock domains are selected from the synthesized clocks as shown in Figure 9 below. These include:

1. Input Domain Clock (IP_CLK). Max = 165MHz
2. Host Interface and On-Chip Microcontroller Clock (OCM_CLK). Max = 100MHz
3. Filter and Display Pixel Clock (DP_CLK). Max = 135MHz
4. Source Timing Measurement Domain Clock (IFM_CLK). Max = 50MHz
5. ADC Domain Clock (ACLK). Max = 165MHz.

The clock selection for each domain as shown in the figure below is controlled using the CLOCK_CONFIG registers (index 0x03 and 0x04).

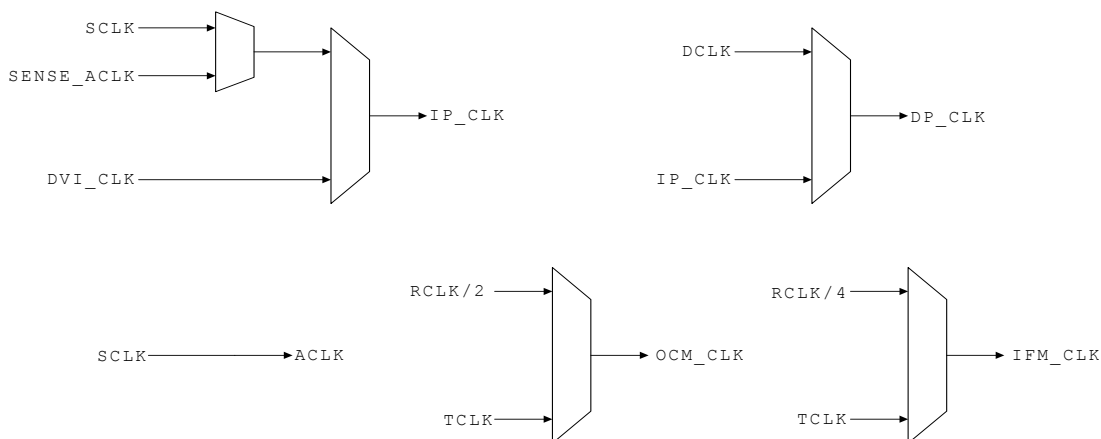

Figure 9. On-chip Clock Domains

4.2 Hardware Reset

Hardware Reset is performed by holding the RESETn pin low for a minimum of 1 μ s. A TCLK input (see Clock Options above) must be applied during and after the reset. When the reset period is complete and RESETn is de-asserted, the power-up sequence is as follows:

1. Reset all registers of all types to their default state (this is 00h unless otherwise specified in the gm5115/25 Register Listing).
2. Force each clock domain into reset. Reset will remain asserted for 64 local clock domain cycles following the de-assertion of RESETn.
3. Operate the OCM_CLK domain at the TCLK frequency.
4. Preset the RCLK PLL to output ~200MHz clock (assumes 14.3MHz TCLK crystal frequency).
5. Wait for RCLK PLL to Lock. Then, switch the OCM_CLK domain to operate from the bootstrap selected clock.
6. If a pull-up resistor is installed on ROM_ADDR9 pin (see Table 18), then the OCM becomes active as soon as OCM_CLK is stable. Otherwise, the OCM remains in reset until OCM_CONTROL register (0x22) bit 1 is enabled.

4.3 Analog to Digital Converter (ADC)

The gm5115/25 chip has three ADC's (analog-to-digital converters), one for each color (red, green, and blue).

4.3.1 ADC Pin Connection

The analog RGB signals are connected to the gm5115/25 as described below:

Table 14. Pin Connection for RGB Input with HSYNC/VSYNC

Pin Name	ADC Signal Name
Red+	Red
Red-	Terminate as illustrated in Figure 10
Green+	Green
Green-	Terminate as illustrated in Figure 10
Blue+	Blue
Blue-	Terminate as illustrated in Figure 10
HSYNC	Horizontal Sync (Terminate as illustrated in Figure 10)
VSYNC	Vertical Sync (Terminate as with HSYNC illustrated in Figure 10)

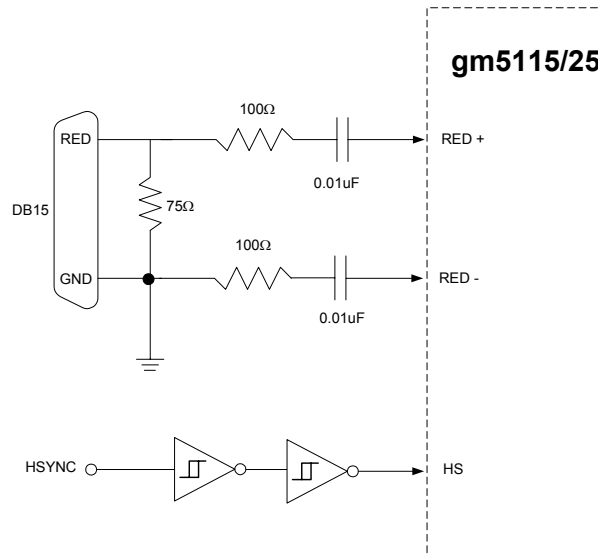

Figure 10. Example ADC Signal Terminations

Please note that it is very important to follow the recommended layout guidelines for the circuit shown in Figure 10. These are described in "gm5115/25 Layout Guidelines" document number C5115-SLG-01A.

4.3.2 ADC Characteristics

The table below summarizes the characteristics of the ADC:

Table 15. ADC Characteristics

	MIN	TYP	MAX	NOTE
Track & Hold Amp Bandwidth		290 MHz		Guaranteed by design. Note that the Track & Hold Amp Bandwidth is programmable. 290 MHz is the maximum setting.
Full Scale Adjust Range at RGB Inputs	0.55 V		0.90 V	
Full Scale Adjust Sensitivity		+/- 1 LSB		Measured at ADC Output. Independent of full-scale RGB input.
Zero Scale Adjust Sensitivity		+/- 1 LSB		Measured at ADC Output.
Sampling Frequency (Fs)	10 MHz		162.5 MHz	
Differential Non-Linearity (DNL)		+/-0.5 LSB	+/-0.9 LSB	Fs = 135 MHz
No Missing Codes				Guaranteed by test.
Integral Non-Linearity (INL)		+/- 1.5 LSB		Fs =135 MHz
Channel to Channel Matching		+/- 0.5 LSB		

Note that input formats with resolutions or refresh rates higher than that supported by the LCD panel are supported as recovery modes only. This is called RealRecovery™. For example, it may be necessary to shrink the image. This may introduce image artifacts. However, the image is clear enough to allow the user to change the display properties.

The gm5115/25 ADC has a built-in clamp circuit for AC-coupled inputs. By inserting series capacitors (about 10 nF), the DC offset of an external video source can be removed. The clamp pulse position and width are programmable.

4.3.3 Clock Recovery Circuit

The SDDS (Source Direct Digital Synthesis) clock recovery circuit generates the clock used to sample analog RGB data (IP_CLK or source clock). This circuit is locked to HSYNC of the incoming video signal.

Patented digital clock synthesis technology makes the gm5115/25 clock circuits resistant to temperature/voltage drift. Using DDS (Direct Digital Synthesis) technology, the clock recovery circuit can generate any IP_CLK clock frequency within the range of 10MHz to 165MHz.

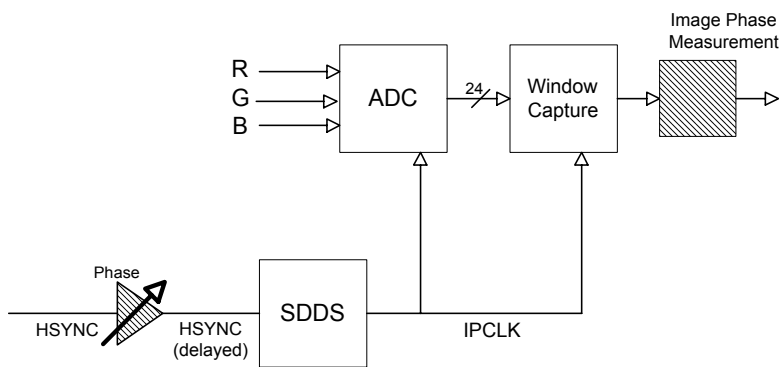

Figure 11. gm5115/25 Clock Recovery

4.3.4 Sampling Phase Adjustment

The programmable ADC sampling phase is adjusted by delaying the HSYNC input to the SDDS. The accuracy of the sampling phase is checked and the result read from a register. This feature enables accurate auto-adjustment of the ADC sampling phase.

4.3.5 ADC Capture Window

Figure 12 below illustrates the capture window used for the ADC input. In the horizontal direction the capture window is defined in IP_CLKs (equivalent to a pixel count). In the vertical direction it is defined in lines.

All the parameters beginning with “Source” are programmed gm5115/25 registers values. Note that the Input Vertical Total is solely determined by the input and is not a programmable parameter.

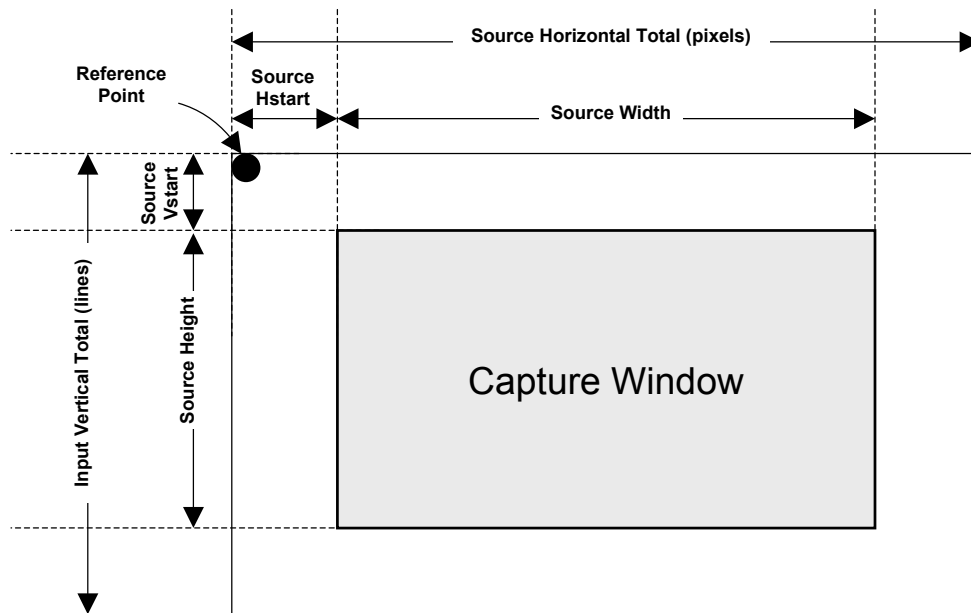

Figure 12. ADC Capture Window

The Reference Point marks the leading edge of the first internal HSYNC following the leading edge of an internal VSYNC. Both the internal HSYNC and the internal VSYNC are derived from external HSYNC and VSYNC inputs.

Horizontal parameters are defined in terms of single pixel increments relative to the internal horizontal sync. Vertical parameters are defined in terms of single line increments relative to the internal vertical sync.

For ADC interlaced inputs, the gm5115/25 may be programmed to automatically determine the field type (even or odd) from the VSYNC/HSYNC relative timing. See Input Format Measurement, Section 4.6.

4.4 Ultra-Reliable Digital Visual Receiver (DVI Rx)

The Ultra-Reliable DVI™ receiver block of the gm5115/25 is compliant with DVI1.0 single link specifications. Digital Visual Interface (DVI) is a standard that uses Transition Minimized Differential Signaling protocol (TMDS). This block supports an input clock frequency ranging from 20 MHz to 165 MHz.

4.4.1 DVI Receiver Characteristics

Table 16 summarizes the characteristics of the four Receiver Pair inputs. Please note that it is very important to follow the recommended layout guidelines for these signals. These are described in "gm5115/25 Layout Guidelines" document number C5115-SLG-01A.

Table 16. DVI Receiver Characteristics

	MIN	TYP	MAX	NOTE
DC Characteristics				
Differential Input Voltage	150mV		1200mV	
Input Common Mode Voltage	AVDD -300m V		AVDD -37mV	
Behavior when Transmitter Disable	AVDD -10mV		AVDD +10mV	
AC Characteristics				
Input clock frequency	20 MHz		165 MHz	
Input differential sensitivity (Peak-to-peak)	150mV			
Max differential input (peak-to-peak)			1560 mV	
Allowable Intra-Pair skew at Receiver			250 ps	Input clock = 160 MHz
Allowable Inter-Pair skew at Receiver			4.0 ns	
Worst case differential input clock jitter tolerance			188 ps	

Note that input formats with resolutions or refresh rates higher than that supported by the LCD panel are supported as recovery modes only. This is called RealRecovery™. For example, it may be necessary to shrink the image. This may introduce image artifacts. However, the image is clear enough to allow the user to change the display properties.

Through register programming, the receiver unit may be placed in one of three states:

- **Active:** The receiver block is fully on and running.
- **Standby:** Only the RC (clock) channel remains active. Data and other control signals are not decoded.
- **Off:** The receiver block is powered down.

4.4.2 DVI Capture Window

DE (Display Enable), HSYNC and VSYNC are synthesized internally by examining the active regions of each line and compensating for possible source timing errors and/or embedded HSYNC / VSYNC jitter.

There are two ways to define the DVI capture region:

CREF Capture - In this mode the usual active window parameters must be programmed as with ADC inputs (see Section 4.3.5.).

DE Capture - In this mode the active window code embedded in the DVI signal defines the active window automatically. Only the active width and active length parameters obtained by performing Input Format Measurement (IFM) need be programmed.

4.4.3 High-Bandwidth Digital Content Protection (HDCP)

Note: This section applies to the HDCP-enabled chip versions gm5115-H and gm5125-H but not the standard versions gm5115 and gm5125.

The HDCP system allows authentication of a video receiver by a video transmitter, decryption of transmitter-encoded video data by the receiver, and periodic renew-ability of authentication during transmission. The gm5115/25 implements circuitry to allow full support of the HDCP 1.0 protocol for DVI inputs.

For enhanced security, Genesis provides a means of storing and accessing the secret key given to individual monitor units in an encrypted format.

Further details of the protocol and theory of the system can be found in the *High-bandwidth Digital Content Protection System* specification (see www.digital-cp.com).

4.5 Test Pattern Generator (TPG)

The gm5115/25 contains hundreds of test patterns, some of which are shown in Figure 13. Once programmed, the gm5115/25 test pattern generator can replace a video source (e.g. a PC) during factory calibration and test. This simplifies the test procedure and eliminates the possibility of image noise being injected into the system from the source. The foreground and background colors are programmable. In addition, the gm5115/25 OSD controller can be used to produce other patterns.

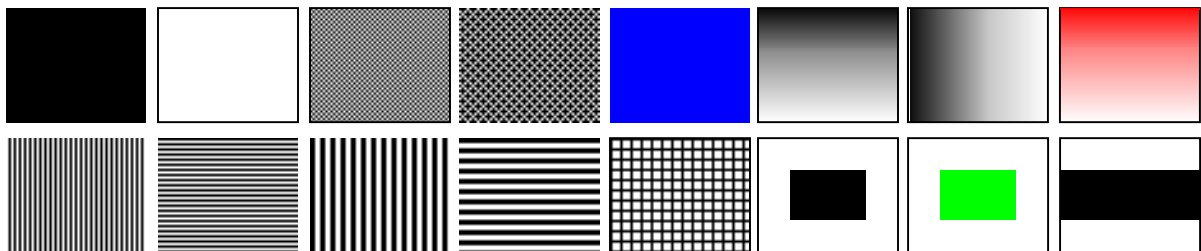

Figure 13. Some of gm5115/25 built-in test patterns

The DDC2Bi port can be used for factory testing. This is illustrated in Figure 14. The factory test station connects to the gm5115/25 through the Direct Data Channel (DDC) of the DSUB15 or DVI connectors. Then, the PC can make gm5115/25 display test patterns (see section 4.5). A camera can be used to automate the calibration of the LCD panel.

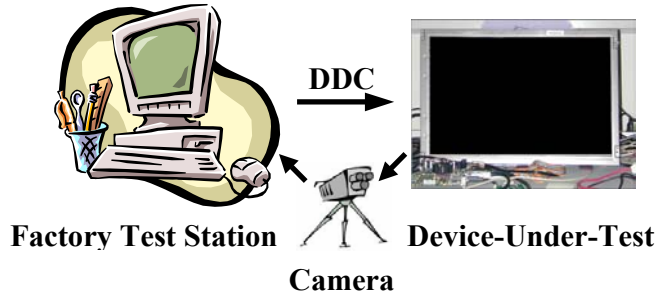

Figure 14. Factory Calibration and Test Environment

4.6 Input Format Measurement (IFM)

The gm5115/25 has an Input Format Measurement block (the IFM) providing the capability of measuring the horizontal and vertical timing parameters of the input video source. This information may be used to determine the video format and to detect a change in the input format. It is also capable of detecting the field type of interlaced formats.

The IFM features a programmable reset, separate from the regular gm5115/25 soft reset. This reset disables the IFM, reducing power consumption. The IFM is capable of operating while the gm5115/25 is running in power-down mode.

Horizontal measurements are measured in terms of the selected IFM_CLK (either TCLK or RCLK/4), while vertical measurements are measured in terms of HSYNC pulses.

For an overview of the internally synthesized clocks, see section 4.1.

4.6.1 HSYNC / VSYNC Delay

The active input region captured by the gm5115/25 is specified with respect to internal HSYNC and VSYNC. By default, internal syncs are equivalent to the HSYNC and VSYNC at the input pins and thus force the captured region to be bounded by external HSYNC and VSYNC timing. However, the gm5115/25 provides an internal HSYNC and VSYNC delay feature that removes this limitation. This feature is available for use with both the ADC input and the DVI Rx (DE-regeneration mode). By delaying the sync internally, the gm5115/25 can capture data that spans across the sync pulse.

It is possible to use HSYNC and VSYNC delay for image positioning. (Alternatively, Source_HSTART and Source_VSTART in Figure 12 are used for image positioning of analog input.) Taken to an extreme, the intentional movement of images across apparent HSYNC and VSYNC boundaries creates a horizontal and/or vertical wrap effect.

HSYNC is delayed by a programmed number of selected input clocks.

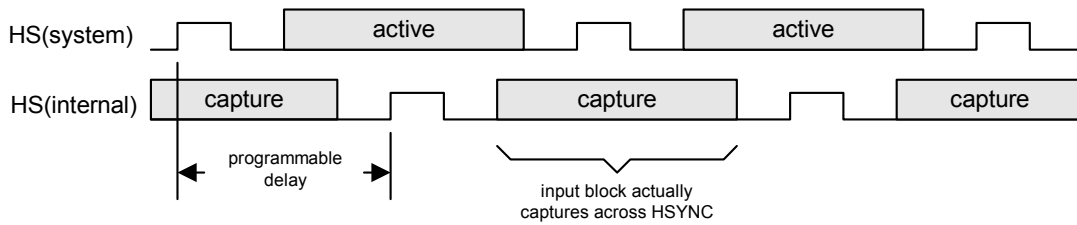

Figure 15. HSYNC Delay

Delayed horizontal sync may be used to solve a potential problem with VSYNC jitter with respect to HSYNC. VSYNC and HSYNC are generally driven active coincidentally, but with different paths to the gm5115/25 (HSYNC is often regenerated from a PLL). As a result, VSYNC may be seen earlier or later. Because VSYNC is used to reset the line counter and HSYNC is used to increment it, any difference in the relative position of HSYNC and VSYNC is seen on-screen as vertical jitter. By delaying the HSYNC a small amount, it can be ensured that VSYNC always resets the line counter prior to it being incremented by the “first” HSYNC.

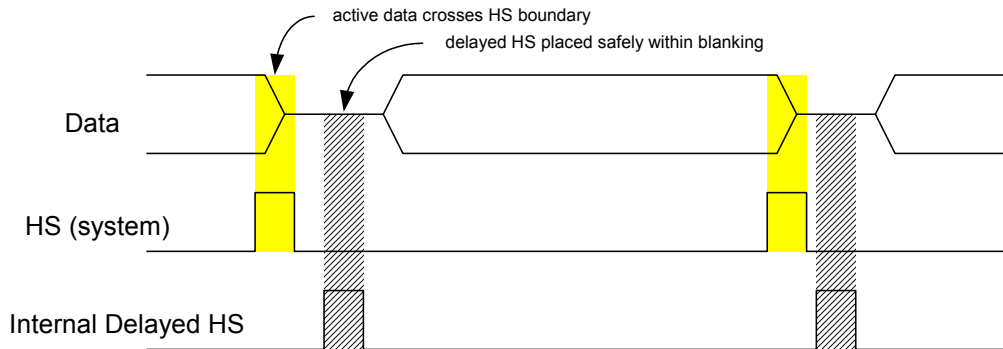

Figure 16. Active Data Crosses HSYNC Boundary

4.6.2 Horizontal and Vertical Measurement

The IFM is able to measure the horizontal period and active high pulse width of the HSYNC signal, in terms of the selected clock period (either TCLK or RCLK/4.). Horizontal measurements are performed on only a single line per frame (or field). The line used is programmable. It is able to measure the vertical period and VSYNC pulse width in terms of rising edges of HSYNC.

Once enabled, measurement begins on the rising VSYNC and is completed on the following rising VSYNC. Measurements are made on every field / frame until disabled.

4.6.3 Format Change Detection

The IFM is able to detect changes in the input format relative to the last measurement and then alert both the system and the on-chip microcontroller. The microcontroller sets a measurement difference threshold separately for horizontal and vertical timing. If the current field / frame

timing is different from the previously captured measurement by an amount exceeding this threshold, a status bit is set. An interrupt can also be programmed to occur.

4.6.4 Watchdog

The watchdog monitors input VSYNC / HSYNC. When any HSYNC period exceeds the programmed timing threshold (in terms of the selected IFM_CLK), a register bit is set. When any VSYNC period exceeds the programmed timing threshold (in terms of HSYNC pulses), a second register bit is set. An interrupt can also be programmed to occur.

4.6.5 Internal Odd/Even Field Detection

The IFM has the ability to perform field decoding of interlaced inputs to the ADC. The user specifies start and end values to outline a “window” relative to HSYNC. If the VSYNC leading edge occurs within this window, the IFM signals the start of an ODD field. If the VSYNC leading edge occurs outside this window, an EVEN field is indicated (the interpretation of odd and even can be reversed). The window start and end points are selected from a predefined set of values.

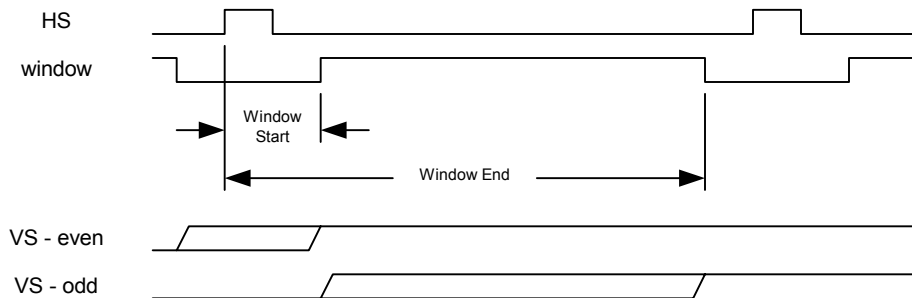

Figure 17. ODD/EVEN Field Detection

4.6.6 Input Pixel Measurement

The gm5115/25 provides a number of pixel measurement functions intended to assist in configuring system parameters such as pixel clock, SDDS sample clocks per line and phase setting, centering the image, or adjusting the contrast and brightness.

4.6.7 Image Phase Measurement

This function measures the sampling phase quality over a selected active window region. This feature may be used when programming the source DDS to select the proper phase setting. Please refer to the gm5115/25 Programming Guide for the optimized algorithm.

4.6.8 Image Boundary Detection

The gm5115/25 performs measurements to determine the image boundary. This information is used when programming the Active Window and centering the image.

4.6.9 Image Auto Balance

The gm5115/25 performs measurements on the input data that are used to adjust brightness and contrast.

4.7 RealColor™ Digital Color Controls

The gm5115/25 provides high-quality digital color controls. These consist of a subtractive “black level” stage, followed by a full 3x3 RGB matrix multiplication stage, followed by an signed offset stage as shown in Figure 18.

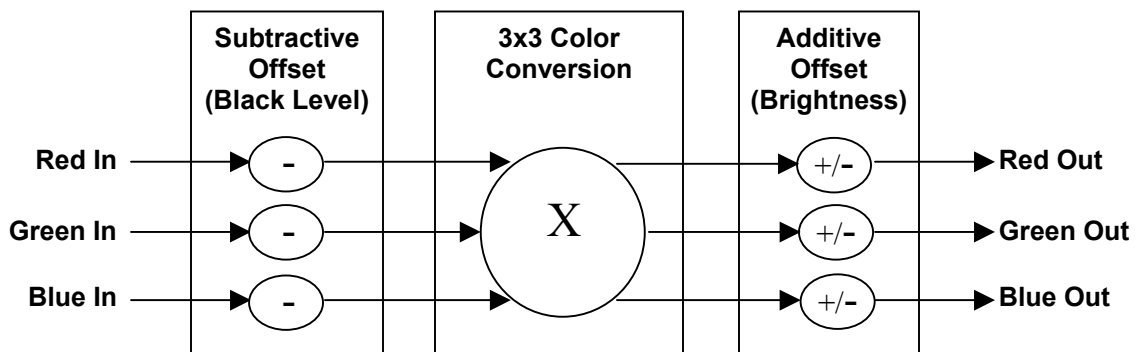

Figure 18. RealColor™ Digital Color Controls

This structure can accommodate all RGB color controls such as black-level (subtractive stage), contrast (multiplicative stage), and brightness (signed additive offset). In addition, it supports all YUV color controls including brightness (additive factor applied to Y), contrast (multiplicative factor applied to Y), hue (rotation of U and V through an angle) and saturation (multiplicative factor applied to both Y and V).

To provide the highest color purity all mathematical functions use 10 bits of accuracy. The final result is then dithered to eight or six bits (as required by the LCD panel).

4.7.1 RealColor™ Flesh tone Adjustment

The human eye is more sensitive to variations of flesh tones than other colors; for example, the user may not care if the color of grass is modified slightly during image capture and/or display. However, if skin tones are modified by even a small amount, it is unacceptable. The gm5115/25 features flesh tone adjustment capabilities. This feature is not based on lookup tables, but rather a manipulation of YUV-channel parameters. Flesh tone adjustment is available for all inputs.

4.7.2 Color Standardization and sRGB Support

Internet shoppers may be very picky about what color they experience on the display. Gm5115/25 RealColor™ digital color controls can be used to make the color response of an LCD monitor compliant with standard color definitions, such as sRGB. sRGB is a standard for color exchange proposed by Microsoft and HP (see www.srgb.com). gm5115/25 RealColor controls can be used to make LCD monitors sRGB compliant, even if the native response of the LCD panel itself is not. For more information on sRGB compliance using gm5115/25 family devices please refer to the sRGB application brief C5115-APB-02A.

4.8 High-Quality Scaling

The gm5115/25 zoom/shrink scaler uses an adaptive scaling technique proprietary to Genesis Microchip Inc., and provides high quality scaling of real time video and graphics images. An input field/frame is scalable in both the vertical and horizontal dimensions.

Interlaced fields may be spatially de-interlaced by vertically scaling and repositioning the input fields to align with the output display's pixel map.

4.8.1 Variable Zoom Scaling

The gm5115/25 scaling filter can combine its advanced scaling with a pixel-replication type scaling function. This is useful for improving the sharpness and definition of graphics when scaling at high zoom factors (such as VGA to XGA).

4.8.2 Horizontal and Vertical Shrink

A shrink function may be performed on the input data. This is an arbitrary horizontal active resolution reduction to between (50% + 1 pixel) to 100% of the input. For example, this allows SXGA 1280 pixels to be displayed as 1024 (XGA).

The gm5115/25 provides an arbitrary vertical shrink down to (50% + 1 line) of the original image size. Together with the arbitrary horizontal shrink, this allows the gm5115/25 to capture and display images one VESA standard format larger than the native display resolution. For example, SXGA may be captured and displayed on an XGA panel.

4.8.3 Moiré Cancellation

The gamma curve and other non-linearities can affect the energy distribution of pixels when scaled to different areas of the screen. This is an example of the Moiré effect. The gm5115/25 has hardware features to negate the Moiré effect, improving the scaling quality.

4.9 Bypass Options

The gm5115/25 has the capability to completely bypass internal processing. In this case, captured input signals and data are passed, with a small latency, straight through to the display output. The gm5115/25 is also able to bypass the zoom filter and the gamma LUT.

4.10 Gamma Look-Up-Table (LUT)

The gm5115/25 provides an 8 to 10-bit look-up table (LUT) for each input color channel intended for Gamma correction and to compensate for a non-linear response of the LCD panel. A 10-bit output results in an improved color depth control. The 10-bit output is then dithered down to 8 bits (or 6 bits) per channel at the display (see section 4.11.3 below). The LUT is user-programmable to provide an arbitrary transfer function. Gamma correction occurs after the zoom / shrink scaling block. If bypassed, the LUT does not require programming.

4.11 Display Output Interface

The Display Output Port provides data and control signals that permit the gm5115/25 to connect to a variety of flat panel or CRT devices. The output interface is configurable for 18 or 24-bit RGB pixels, either single- or double-pixel wide. All display data and timing signals are synchronous with the DCLK output clock.

4.11.1 Display Synchronization

Refer to section 4.1 for information regarding internal clock synthesis.

The gm5115/25 supports the following display synchronization modes:

- **Frame Sync Mode:** The display frame rate is synchronized to the input frame or field rate. This mode is used for standard operation.
- **Free Run Mode:** No synchronization. This mode is used when there is no valid input timing (i.e. to display OSD messages or a splash screen) or for testing purposes. In free-run mode, the display timing is determined only by the values programmed into the display window and timing registers.

4.11.2 Programming the Display Timing

Display timing signals provide timing information so the Display Port can be connected to an external display device. Based on values programmed in registers, the Display Output Port produces the horizontal sync (DHS), vertical sync (DVS), and data enable (DEN) control signals. The figure below provides the registers that define the output display timing.

Horizontal values are programmed in single-pixel increments relative to the leading edge of the horizontal sync signal. Vertical values are programmed in line increments relative to the leading edge of the vertical sync signal.

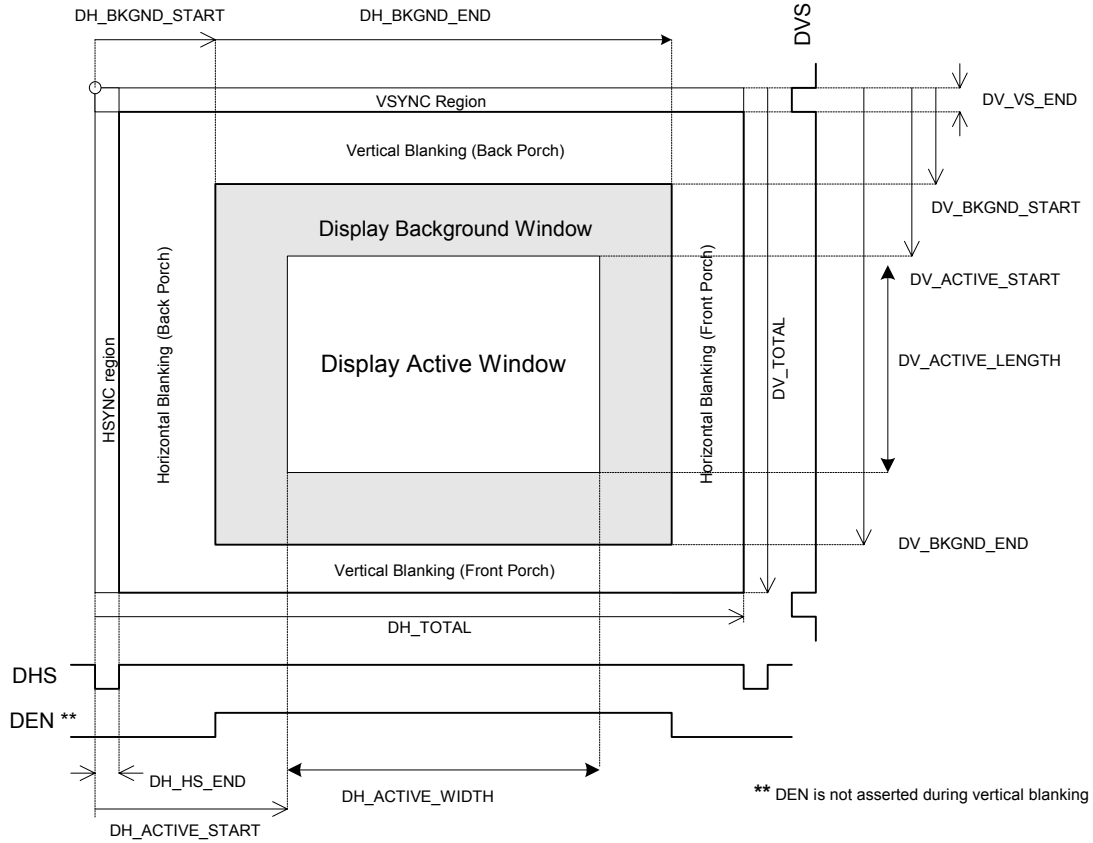

Figure 19. Display Windows and Timing

The double-wide output only supports an even number of horizontal pixels.

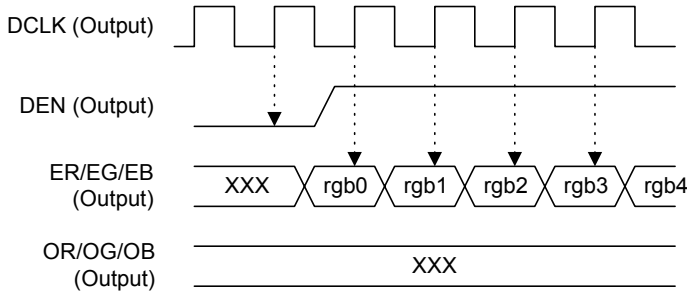

Figure 20. Single Pixel Width Display Data

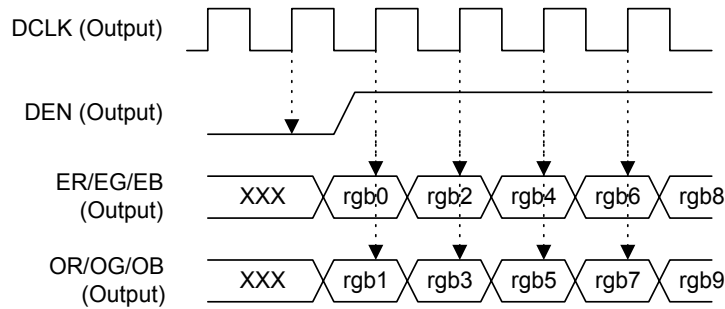

Figure 21. Double Pixel Wide Display Data

4.11.3 Panel Power Sequencing (PPWR, PBIAS)

The gm5115/25 has two dedicated outputs PPWR and PBIAS (pins 113 and 114) to control LCD power sequencing once data and control signals are stable. The timing of these signals is fully programmable.

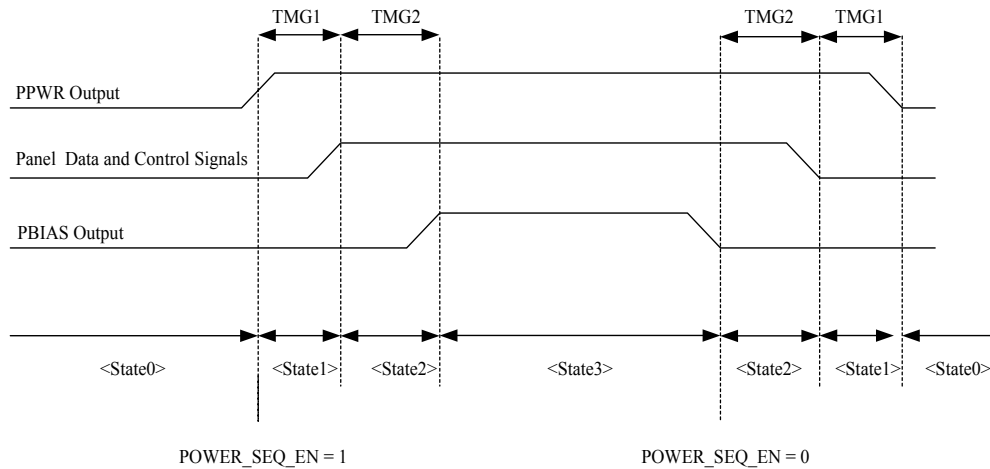

Figure 22. Panel Power Sequencing

4.11.4 Output Dithering

The Gamma LUT outputs a 10-bit value for each color channel. This value is dithered down to either 8-bits for 24-bit per pixel panels, or 6-bits for 18-bit per pixel panels.

The benefit of dithering is that the eye tends to average neighboring pixels and a smooth image free of contours is perceived. Dithering works by spreading the quantization error over neighboring pixels both spatially and temporally. Two dithering algorithms are available: random or ordered dithering. Ordered dithering is recommended when driving a 6-bit panel.

All gray scales are available on the panel output whether using 8-bit panel (dithering from 10 to 8 bits per pixel) or using 6-bit panel (dithering from 10 down to 6 bits per pixel).

4.12 Energy Spectrum Management (ESM)

High spikes in the electromagnetic interference (EMI) power spectrum can cause LCD monitor products to violate emissions standards. The gm5115/25 programmable TCON has many features that can be used to reduce EMI. These include:

- transition minimization,
- drive strength control,
- data staggering,
- even/odd, red/blue, bit 0/7 swapping for reduced trace length,
- slew rate control,
- dual-edge clocking, and
- clock spectrum modulation.

These features eliminate the costs associated with EMI-reducing components and shielding.

4.13 Timing Controller (TCON)

The gm5115/25 features an integrated timing controller (TCON) that connects directly to commercially available row and column drivers. It supports either 18 or 24-bits per pixel in 1 or 2 pixels per clock XGA operation. Also, it supports single or dual-edge clocking modes. Frame, Line (Row) and pixel inversion is available for better image quality. In-Line inversion reduces power consumption and EMI radiation. Data signals have programmable drive strength.

During panel power-up the TCON control signals can be held inactive. This is to provide correct power sequencing that does not damage the panel. The TCON control signals only become active when the panel power sequencing is complete.

4.13.1 Programmable Column Driver Interface

The gm5115/25 column driver interface is highly programmable. gm5115 supports dual bus / dual port, dual bus / one port (both interleave and bank) as well as single bus / single port for XGA column drivers. gm5125 supports dual bus / dual port and dual bus / one port (both interleave and bank) for SXGA column drivers.

The column driver interface consists of the following signals:

OCLK/ECLK – Odd/Even Column Driver bus clock. OCLK and ECLK have a programmable phase control (0-7ns) and programmable polarities. Even output data bus (ERGB) can be skewed $\frac{1}{2}$ clock (early) to reduce the number of outputs switching simultaneously.

OSP/ESP – Odd/Even Starting Pulse. OSP and ESP have programmable positioning before valid data. They also have programmable polarities.

ORGB[24]/ERGB[24] – Odd/Even 24 bits data bus supports 24 or 18 bits per pixel in 1 or 2 pixels per clock. These signals support even/odd, red/blue and data bit swap. They also have programmable group and inter-group delays (0-7ns).

OPOL/EPOL – Odd/Even polarity. With programmable position of OPOL/EPOL, the OPOL/EPOL can be switched when LP is active or before or after LP.

OINV/EINV – Odd/Even data transition inversion. These signals provide data inversion capability to reduce electromagnetic interference (EMI). One INV signal can be used (either EINV or OINV), or both.

LP – Load/Latch pulse. The Load/Latch pulse has a programmable width and polarity.

SHC – Output circuit control. This signal has programmable timing similar to OPOL/EPOL. It is optionally available on GPIO6.

TDIV – Horizontal timing. This signal rises with LP and has a programmable falling edge. It is optionally available on GPIO7.

All signals OCLK, ECLK, ORGB, ERGB, OSP, ESP, OPOL, EPOL, OINV, EINV have programmable drive strengths and can be disabled.

Clocks (OCLK/ECLK), Polarities (EPOL/OPOL) and Data (ERGB/ORGB, ESP/OSP) can be blanked separately, during horizontal and/or vertical blanking period (programmable) to reduce power. Clocks and Polarities are forced to zero and Data (ERGB/ORGB) is forced to either white or black during blanking period.

Refer to Figure 23 for the column driver interface timing. See the gm5115/25 programming guide (C5115-DSR-01) for details regarding column driver programming.

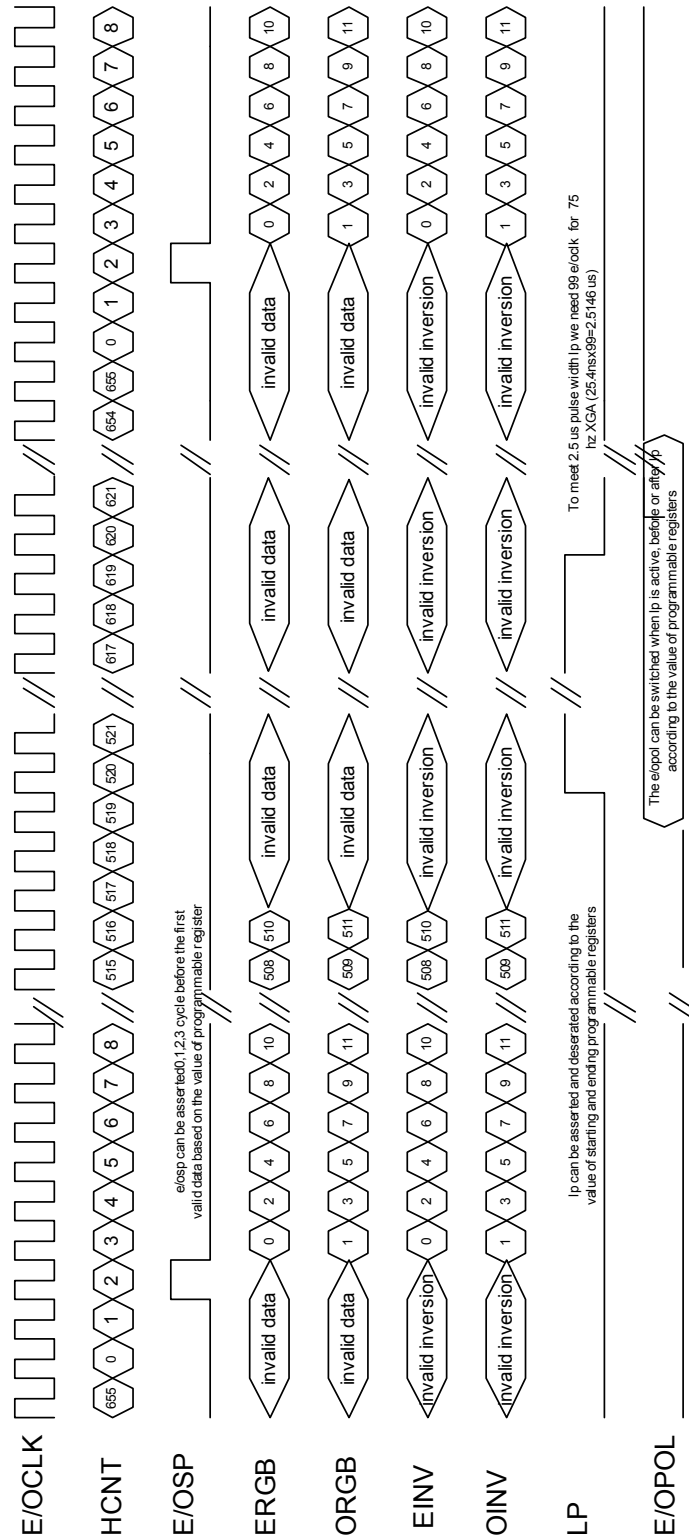

Figure 23. Column Driver Interface Timing

4.13.2 Programmable Row Driver Interface

The gm5115/25 row driver interface supports 2 and 3 voltage row drivers.

The row driver interface consists of the following signals. The starting time and pulse-width of each are fully programmable.

RSP2 – Row Starting Pulse for 2 voltage Row Driver

RSP3 – Row Starting Pulse for 3 voltage Row Driver

ROWCLK – Row/Vertical shift clock

ROE – Row Output Enable or Row Blank Time or Gate Driver Output Enable. This signal is used to control RC discharge time. Note that some vendors support three ROE's for this function to avoid 2 lines being activated at the same time (ROE2 and ROE3 are optionally available on pins GPIO9 and GPIO10). The polarities of ROE, ROE2 and ROE3 are programmable. These signals can be blanked during horizontal and/or vertical blanking to reduce power. In addition, ROE, ROE2 and ROE3 may be staggered.

ROWCLK, ROE, ROE2 and ROE3 have programmable polarities and can be blanked during horizontal and/or vertical blanking period (programmable) to reduce power. Note that ROE2 and ROE3 can be used to drive GV and GVOFF signals required by some row driver ICs.

See the gm5115/25 programming guide (C5115-DSR-01) for details regarding row driver programming.

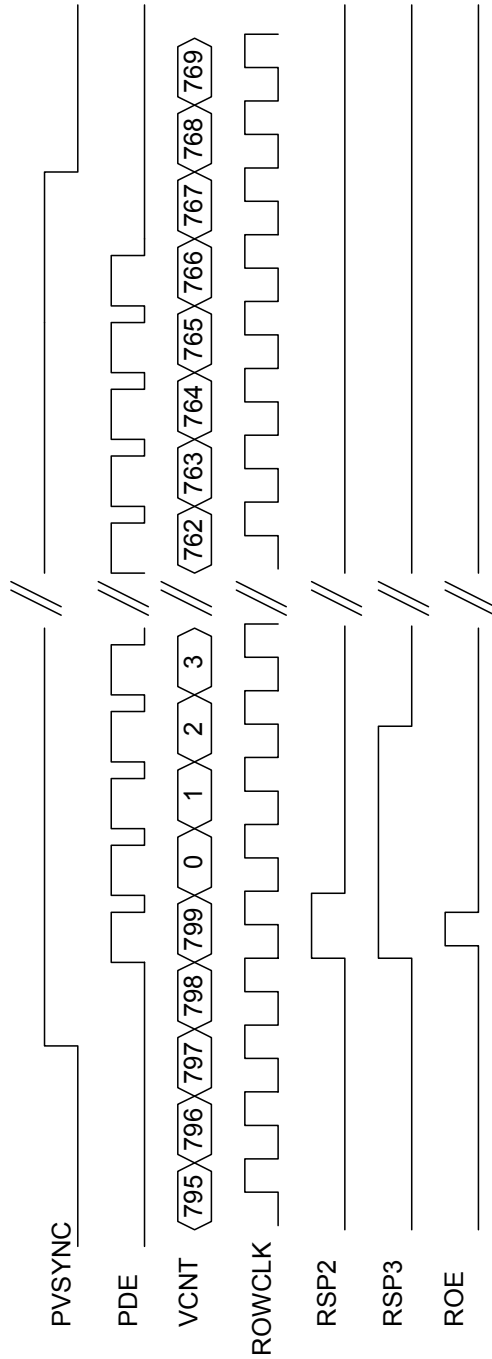

- Notes:
1. The ROWCLK low and high time can be determined by horizontal starting and ending programmable registers
 2. The pulse width of RSP2 and RSP3 based on number of ROWCLKs can be determined by vertical starting and ending programmable registers
 3. The pulse width of ROE can be determined by horizontal starting and ending programmable registers
 4. For example, For 75 Hz XGA the Hor Total Time is 1312x12.7ns = 16.6 us, the low/high time of ROWCLK is 16.6 us/2 = 328 ecoclk

Figure 24. Row Driver Interface Timing

4.14 OSD

The gm5115/25 has a fully programmable, high-quality OSD controller. The graphics are divided into “cells” 12 by 18 pixels in size. The cells are stored in an on-chip static RAM (4096 words by 24 bits) and can be stored as 1-bit per pixel data, 2-bit per pixel data or 4-bit per pixel data. This permits a good compression ratio while allowing more than 16 colors in the image.

Some general features of the gm5115/25 OSD controller include:

OSD Position – The OSD menu can be positioned anywhere on the display region. The reference point is Horizontal and Vertical Display Background Start (DH_BKGND_START and DV_BKGND_START in Figure 19).

OSD Stretch – The OSD image can be stretched horizontally and/or vertically by a factor of two, three, or four. Pixel and line replication is used to stretch the image.

OSD Blending – Sixteen levels of blending are supported for the character-mapped and bitmapped images. One host register controls the blend levels for pixels with LUT values of 128 and greater, while another host register controls the blend levels for pixels with LUT values of 127 and lower. OSD color LUT value 0 is reserved for transparency and is unaffected by the blend attribute.

4.14.1 On-Chip OSD SRAM

The on-chip static RAM (4096 words by 24 bits) stores the cell map and the cell definitions.

In memory, the cell map is organized as an array of words, each defining the attributes of one visible character on the screen starting from upper left of the visible character array. These attributes specify which character to display, whether it is stored as 1, 2 or 4 bits per pixel, the foreground and background colors, blinking, etc.

Registers CELLMAP_XSZ and CELLMAP_YSZ are used to define the visible area of the OSD image. For example, Figure 25 shows a cell map for which CELLMAP_XSZ =25 and CELLMAP_YSZ =10.

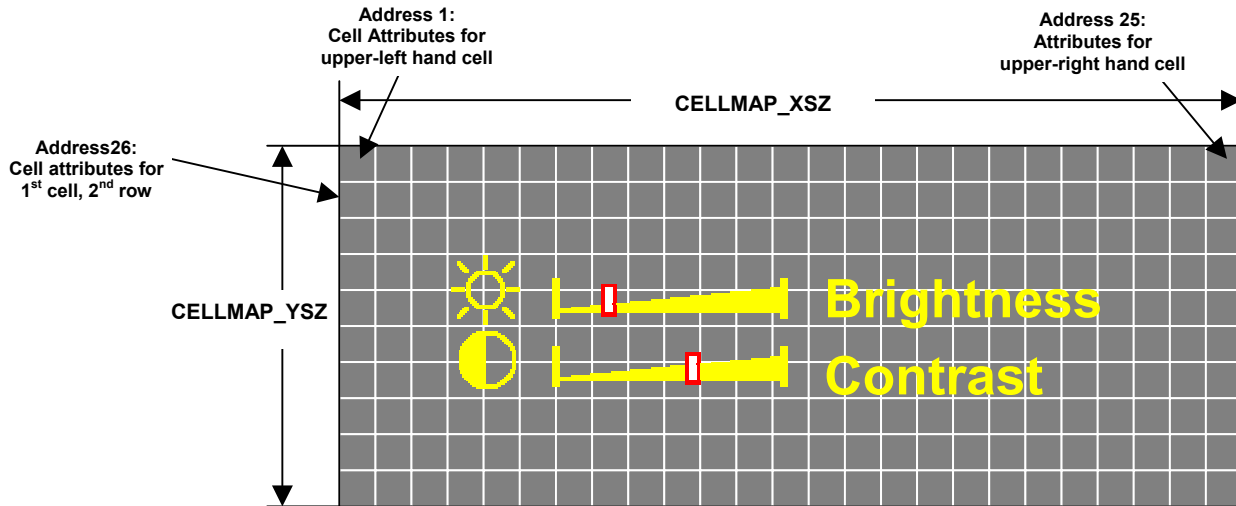

Figure 25. OSD Cell Map

Cell definitions are stored as bit map data. On-chip registers point to the start of 1-bit per pixel definitions, 2-bit per pixel definitions and 4-bit per pixel definitions respectively. 1, 2 and 4-bit per pixel cell definitions require 9, 18 and 36 words of the OSD RAM respectively.

Note that the cell map and the cell definitions share the same on-chip RAM. Thus, the size of the cell map can be traded off against the number of different cell definitions. In particular, the size of the OSD image and the number of cell definitions must fit in OSD SRAM. That is, the following inequality must be satisfied. (Note, the ROUND operation rounds 3.5 to 4).

$$\begin{aligned}
 &(\text{CELLMAP_XSZ}+1) * \text{CELLMAP_YSZ} + \\
 &18 * \text{ROUND}(\text{Number of 1-bit per pixel fonts} / 2) + \\
 &18 * (\text{Number of 2-bit per pixel fonts}) + \\
 &36 * (\text{Number of 4-bit per pixel fonts}) \leq 4096
 \end{aligned}$$

For example, an OSD menu 360 pixels wide by 360 pixels high is 30 cells in width and 20 cells in height. Many of these cells would be the same (e.g. empty). In this case, the menu could contain more than 32 1-bit per pixel cells, 100 2-bit per pixel cells, and 16 4-bit per pixel cells. Of course, different numbers of each type can also be used.

4.14.2 Color Look-up Table (LUT)

Each pixel of a displayed cell is resolved to an 8-bit color code. This selected color code is then transformed to a 24-bit value using a 256 x 24-bit look up table. This LUT is stored in an on-chip RAM that is separate from the OSD RAM. Color index value 0x00 is reserved for transparent OSD pixels.

4.15 On-Chip Microcontroller (OCM)

The gm5115/25 on-chip microcontroller (OCM) serves as the system microcontroller. It programs the gm5115/25 and manages other devices in the system such as the keypad, the back light and non-volatile RAM (NVRAM) using general-purpose input/output (GPIO) pins.

The OCM can operate in two configurations, Standalone configuration and Full-Custom configuration, as illustrated in Figure 26.

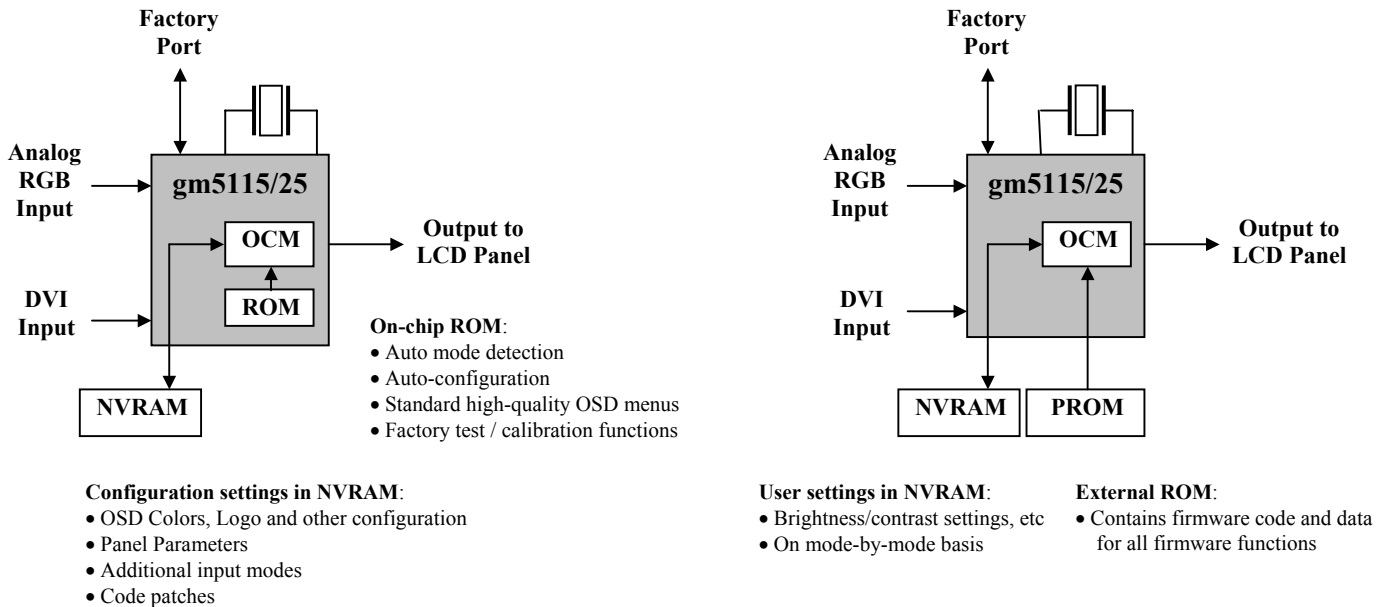

Figure 26A - Standalone Configuration
(No external ROM)

Figure 26B - Full-Custom Configuration
(Program and Data stored in external ROM)

4.15.1 Standalone Configuration

Standalone configuration offers the most simple and inexpensive system solution for generic LCD monitors. In this configuration the OCM executes firmware stored internally in gm5115/25. This is illustrated in Figure 26A. The on-chip firmware provides all the standard functions required in a high-quality generic LCD monitor. This includes mode-detection, auto-configuration and a high-quality standard OSD menu system. No external ROM is required (which reduces BOM cost) and no firmware development effort is required (which reduces time-to-market).

In Standalone configuration many customization parameters are stored in NVRAM. These include the LCD panel timing parameters (including TCON programming), the color scheme and logos used in the OSD menus, the functions provided by the OSD menus, and arbitrary firmware modifications. These customization parameters are described in the Standalone User's Guide (B0108-SUG-01). Based on the customization parameters, G-Wizard (a GUI-based development tool used to program Genesis devices) produces the hex image file for NVRAM. G-Probe is then used to download the NVRAM image file into the NVRAM device. This is illustrated in Figure 27 below.

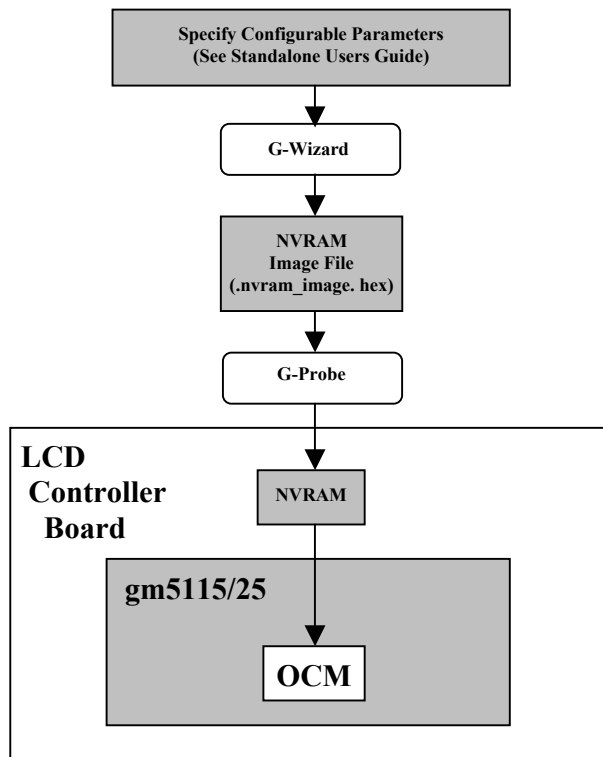

Figure 27. Programming OCM in Standalone Configuration

4.15.2 Full-Custom Configuration

In full-custom configuration the OCM executes a firmware program running from external ROM. This is illustrated in Figure 26B. A parallel port with separate address and data buses is available for this purpose. This port connects directly to standard, commercially available ROM or programmable Flash ROM devices. Normally 64KB or 128KB of ROM is required.

Both instructions and data are fetched from external ROM on a cycle-by-cycle basis. The speed of the accesses on the parallel port is determined by the gm5115/25 internal OCM_CLK. This in turn determines the speed of the external ROM device. For example, if a 14.3 MHz crystal is being used to produce TCLK, and the OCM_CLK is derived from TCLK, then a 45ns ROM can be used.

To program gm5115/25 in full-custom configuration the content of the external ROM is generated using Genesis software development tools G-Wizard and OSD-Workbench. This is illustrated in Figure 28. G-Wizard is a GUI-based tool for capturing system information such as panel timing, support modes, system configuration, etc. OSD-Workbench is a GUI based tool for defining OSD menus and functionality.

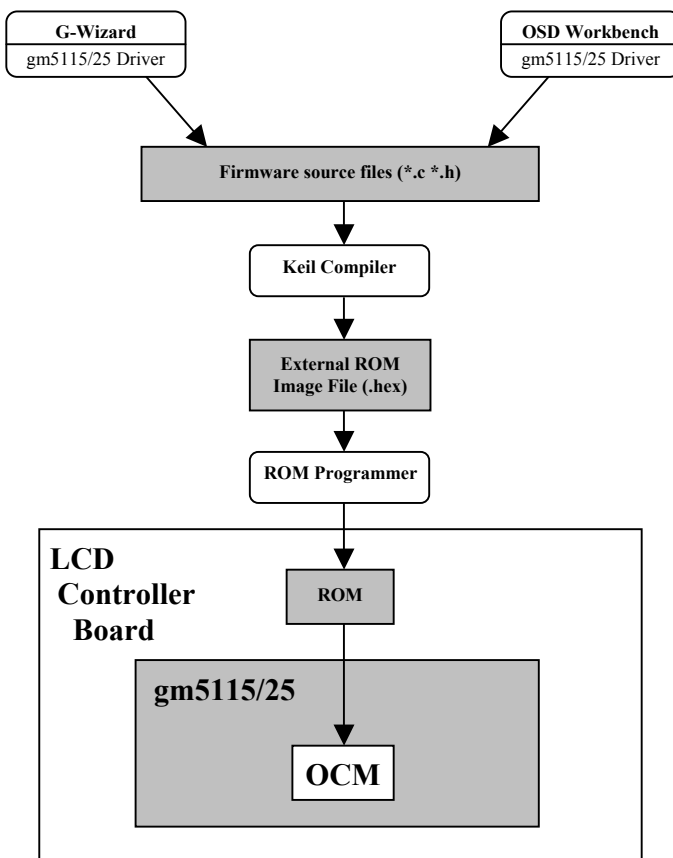

Figure 28. Programming the OCM in Full-Custom Configuration

Genesis recommends using Keil compiler (<http://www.keil.com/>) to compile the firmware source code into a hex file. This hex file is then downloaded into the external ROM using commercially available ROM programmers.

4.15.3 In-System-Programming (ISP) of FLASH ROM Devices

gm5115/25 has hardware to program FLASH ROM devices. In particular, the GPIO11/ROM_WEn pin can be connected to the write enable of the FLASH ROM. Firmware is then used to perform the writes using the gm5115/25 host registers.

4.15.4 UART Interface

The gm5115/25 OCM has an integrated Universal Asynchronous Remote Terminal (UART) port that can be used as a factory debug port. In particular, the UART can be used to 1) read / write chip registers (see section 4.17 below), 2) read / write to NVRAM (see section 4.15.1 above), and 3) read / write to FLASH ROM (see section 4.15.3 above).

The UART is connected to pins GPIO4/UART_DI and GPIO5/UART_DO. gm5115/25 has serial-to-parallel conversion hardware which is accessed by firmware. The baud rate for serial communication is determined by a gm5115/25 host register.

4.15.5 DDC2Bi Interface

The gm5115/25 also features hardware support for DDC2Bi communication over the DDC channel of either the analog or DVI input ports. The specification for the DDC2Bi standard can be obtained from VESA (www.vesa.org). The DDC2Bi port can be used as a factory debug port or for field programming. In particular, the DDC2Bi port can be used to 1) read / write chip registers (see section 4.17 below), 2) read / write to NVRAM (see section 4.15.1 above), and 3) read / write to FLASH ROM (see section 4.15.3 above).

Two pairs of pins are available for DDC2Bi communication. For DDC2Bi communication over the analog VGA connector pins GPIO22/HCLK and GPIO16/HFSn should be connected to the DDC clock and data pins of the analog DSUB15 VGA connector. For DDC2Bi communication over the DVI connector pins GPIO14/DDC_SCL and GPIO15/DDC_SDA should be connected to the DDC clock and data pins of the DVI connector. gm5115/25 contains serial to parallel conversion hardware, that is then accessed by firmware for interpretation and execution of the DDC2Bi command set.

4.15.6 General Purpose Inputs and Outputs (GPIO)

The gm5115/25 has 21 general-purpose input/output (GPIO) pins. These are used by the OCM to communicate with other devices in the system such as keypad buttons, NVRAM, LEDs, audio DAC, etc. Each GPIO has independent direction control, open drain enable, for reading and writing. Note that the GPIO pins have alternate functionality as described in Table 17 below.

Pin Name	Pin Number	Alternate function
GPIO0/PWM0 GPIO1/PWM1 GPIO2/PWM2	40 41 42	PWM0, PWM1 and PWM2 back light intensity controls, as described in section 4.18.2 below.
GPIO3/TIMER1	43	Timer1 input of the OCM.
GPIO4/UART_DI GPIO5/UARD_D0	44 45	OCM UART data in/out signals respectively (section 4.15.3 above).
GPIO6/TCON_SHC GPIO7/TCON_TDIV	46 47	Horizontal timing signals in the TCON column driver interface.
GPIO8/IRQINn	39	OCM external interrupt source (IRQINn).
GPIO9/TCON_ROE2 GPIO10/TCON_ROE3	48 49	Row output enables ROE2 and ROE3 in the TCON row driver interface.
GPIO11/ROM_WEn	50	Write enable for external ROM if programmable FLASH device is used (section 4.15.3 above).
GPIO12/NVRAM_SDA GPIO13/NVRAM_SCL	51 52	Data and clock lines for master 2-wire serial interface to NVRAM when gm5115/25 is used in standalone configuration (section Figure 26).
GPIO14/DDC_SCL GPIO15/DDC_SDA	6 7	Clock and data lines for 2-wire serial interface connected to the Direct Data Channel (DDC) of the DVI input, for passing HDCP keys (see 4.4.3 above) or for DDC2Bi communication (see 4.15.5 above).
GPIO16/HFSn	205	Serial data line for 2-wire host interface or for DDC2Bi communication (see 4.15.5 above).
GPIO17 GPIO18 GPIO19 GPIO20	1 208 207 206	No alternative function.
GPIO21/IRQn	4	OCM interrupt output pin.
GPIO22/HCLK	204	Serial input clock for 2-wire host interface or for DDC2Bi communication (see 4.15.5 above).

Table 17. gm5115/25 GPIOs and Alternate Functions

4.16 Bootstrap Configuration Pins

During hardware reset, the external ROM address pins ROM_ADDR[15:0] are configured as inputs. On the negating edge of RESETn, the value on these pins is latched and stored. This value is readable by the on-chip microcontroller (or an external microcontroller via the host interface). Install a 10K pull-up resistor to indicate a ‘1’, otherwise a ‘0’ is indicated because ROM_ADDR[15:0] have a 60KΩ internal pull-down resistor.

Signal Name	Pin Name	Description
HOST_ADDR(4:0) USER_BITS(4:0)	ROM_ADDR(4:0)	If using 2-wire host protocol, these are bits 4:0 of the serial bus device address. Otherwise, these settings are available for reading from a status register but are otherwise unused by the gm5115/25. Used for “soft” configuration settings.
HOST_ADDR(5)	ROM_ADDR5	If using 2-wire host protocol, this is bit 5 of serial the bus device address. Otherwise, program this bit to 0.
HOST_ADDR(6)	ROM_ADDR6	If using 2-wire host protocol, this is bit 6 of the serial bus device address. Otherwise, program this bit to 0.
HOST_PROTOCOL	ROM_ADDR7	Program this bit to 0 for 2-wire host protocol operation.
HOST_PORT_EN	ROM_ADDR8	Program this bit to 0 for 2-wire host protocol operation.
OCM_START	ROM_ADDR9	Determines the operating condition of the OCM after HW reset: 0 = OCM remains in reset until enabled by register bit. 1 = OCM becomes active after OCM_CLK is stable.
USER_BITS(7:5)	ROM_ADDR(12:10)	These settings are available for reading from a status register but are otherwise unused by the gm5115/25.
OSC_SEL	ROM_ADDR13	Selects reference clock source: 0 = XTAL and TCLK pins are connected to a crystal oscillator (see Figure 4). 1 = TCLK input is driven with a single-ended TTL/CMOS clock oscillator (see Figure 7).
OCM_ROM_CNFG(1)	ROM_ADDR14	Together with OCM_CONTROL register (0x22) bit 4, this bit selects internal/external ROM configuration. 0 = All 48K of ROM is internal. 1 = All 48K of ROM is in external ROM using ROM_ADDR15:0 address outputs if register 0x22 bit 4 is 0. If register 0x22 bit 4 is 1, 0-32K ROM is internal, and 32K-48K ROM is external using ROM_ADDR13:0 address outputs.

Table 18. Bootstrap Signals

4.17 Host Interface

gm5115/25 contains many internal registers that control its operation. These are described in the gm5115 Family Register Listing (C5115-DSL-01).

A serial host interface is provided to allow an external device to peek and poke registers in the gm5115/25. This is done using a 2-wire serial protocol. Note that 2-wire host interface requires bootstrap settings as described in Table 18.

An arbitration mechanism ensures that register accesses from the OCM and the 2-wire host interface port are always serviced (time division multiplexing).

4.17.1 Host Interface Command Format

Transactions on the 2-wire host protocol occurs in integer multiples of bytes (i.e. 8 bits or two nibbles respectively). These form an instruction byte, a device register address and/or one or more data bytes. This is described in Table 19.

The first byte of each transfer indicates the type of operation to be performed by the gm5115/25. The table below lists the instruction codes and the type of transfer operation. The content of bytes that follow the instruction byte will vary depending on the instruction chosen. By utilizing these modes effectively, registers can be quickly configured.

The two LSBs of the instruction code, denoted ‘A9’ and ‘A8’ in Table 19 below, are bits 9 and 8 of the internal register address respectively. Thus, they should be set to ‘00’ to select a starting register address of less than 256, ‘01’ to select an address in the range 256 to 511, and ‘10’ to select an address in the range 512 to 767. These bits of the address increment in Address Increment transfers. The unused bits in the instruction byte, denoted by ‘x’, should be set to ‘1’.

Table 19. Instruction Byte Map

Bit 7 6 5 4 3 2 1 0	Operation Mode	Description
0 0 0 1 x x A9 A8	Write Address Increment	Allows the user to write a single or multiple bytes to a specified starting address location. A Macro operation will cause the internal address pointer to increment after each byte transmission. Termination of the transfer will cause the address pointer to increment to the next address location.
0 0 1 0 x x A9 A8	Write Address No Increment (for table loading)	
1 0 0 1 x x A9 A8	Reserved	Allows the user to read multiple bytes from a specified starting address location. A Macro operation will cause the internal address pointer to increment after each read byte. Termination of the transfer will cause the address pointer to increment to the next address location.
1 0 1 0 x x A9 A8	Read Address No Increment (for table reading)	
0 0 1 1 x x A9 A8 0 1 0 0 x x A9 A8 1 0 0 0 x x A9 A8 1 0 1 1 x x A9 A8 1 1 0 0 x x A9 A8	Reserved	
0 0 0 0 x x A9 A8 0 1 0 1 x x A9 A8 0 1 1 0 x x A9 A8 0 1 1 1 x x A9 A8 1 1 0 1 x x A9 A8 1 1 1 0 x x A9 A8 1 1 1 1 x x A9 A8	Spare	No operation will be performed

4.17.2 2-wire Serial Protocol

The 2-wire protocol consists of a serial clock HCLK (pin number 204) and bi-directional serial data line HFSn (pin number 205). The bus master drives HCLK and either the master or slave

can drive the HFSn line (open drain) depending on whether a read or write operation is being performed. The gm5115/25 operates as a slave on the interface.

The 2-wire protocol requires each device be addressable by a 7-bit identification number. The gm5115/25 is initialized on power-up to 2-wire mode by asserting bootstrap pins HOST_PROTOCOL=0 and the device identification number on HOST_ADDR(6:0) on the rising edge of RESETn (see Table 18). This provides flexibility in system configuration with multiple devices that can have the same address.

A 2-wire data transfer consists of a stream of serially transmitted bytes formatted as shown in the figure below. A transfer is initiated (START) by a high-to-low transition on HFSn while HCLK is held high. A transfer is terminated by a STOP (a low-to-high transition on HFSn while HCLK is held high) or by a START (to begin another transfer). The HFSn signal must be stable when HCLK is high, it may only change when HCLK is low (to avoid being misinterpreted as START or STOP).

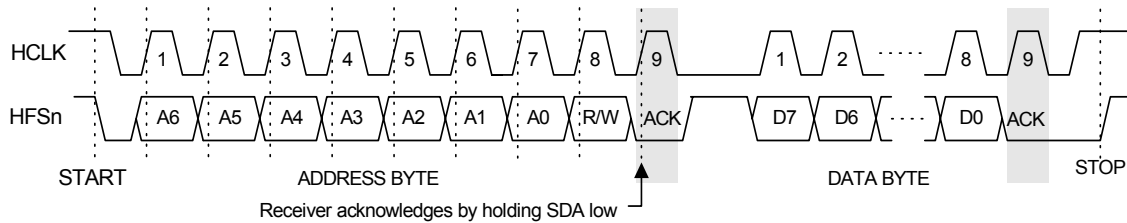

Figure 29. 2-Wire Protocol Data Transfer

Each transaction on the HFSn is in integer multiples of 8 bits (i.e. bytes). The number of bytes that can be transmitted per transfer is unrestricted. Each byte is transmitted with the most significant bit (MSB) first. After the eight data bits, the master releases the HFSn line and the receiver asserts the HFSn line low to acknowledge receipt of the data. The master device generates the HCLK pulse during the acknowledge cycle. The addressed receiver is obliged to acknowledge each byte that has been received.

The Write Address Increment and the Write Address No Increment operations allow one or multiple registers to be programmed with only sending one start address. In Write Address Increment, the address pointer is automatically incremented after each byte has been sent and written. The transmission data stream for this mode is illustrated in Figure 30 below. The highlighted sections of the waveform represent moments when the transmitting device must release the HFSn line and wait for an acknowledgement from the gm5115/25 (the slave receiver).

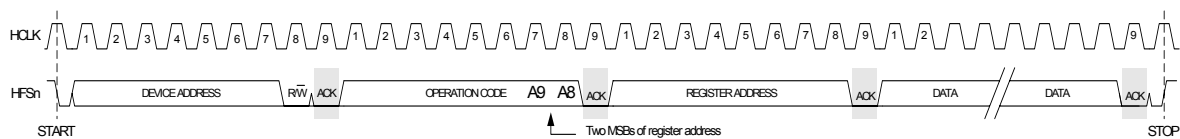

Figure 30. 2-Wire Write Operations (0x1x & 0x2x)

The Read Address No Increment (0xA0) operation is illustrated in Figure 31. The highlighted sections of the waveform represent moments when the transmitting device must release the HFSn line and waits for an acknowledgement from the master receiver.

Note that on the last byte read, no acknowledgement is issued to terminate the transfer.

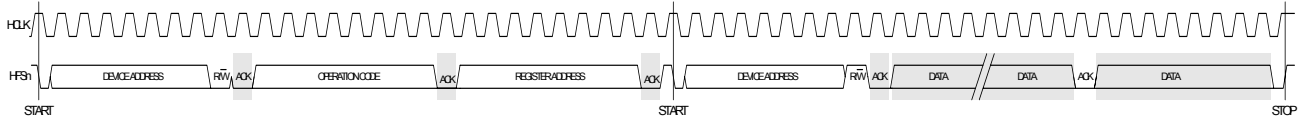

Figure 31. 2-Wire Read Operation (0xAx)

Please note that in all the above operations the operation code includes two address bits, as described in Table 19.

4.18 Miscellaneous Functions

4.18.1 Power Down Operation

The gm5115/25 provides a low power state in which the clocks to selected parts of the chip may be disabled (see Table 21).

4.18.2 Pulse Width Modulation (PWM) Back Light Control

Many of today’s LCD back light inverters require both a PWM input and variable DC voltage to minimize flickering (due to the interference between panel timing and inverter’s AC timing), and adjust brightness. Most LCD monitor manufacturers currently use a microcontroller to provide these control signals. To minimize the burden on the external microcontroller, the gm5115/25 generates these signals directly.

There are three pins available for controlling the LCD back light, PWM0 (GPIO0), PWM1 (GPIO1) and PWM2 (GPIO2). The duty cycle of these signals is programmable. They may be connected to an external RC integrator to generate a variable DC voltage for a LCD back light inverter. Panel HSYNC is used as the clock for a counter generating this output signal.

5. ELECTRICAL SPECIFICATIONS

The following targeted specifications have been derived by simulation.

5.1 Preliminary DC Characteristics

Table 20. Absolute Maximum Ratings

PARAMETER	SYMBOL	MIN	TYP	MAX	UNITS
3.3V Supply Voltages ^(1,2)	V _{VDD_3.3}	-0.3		3.6	V
2.5V Supply Voltages ^(1,2)	V _{VDD_2.5}	-0.3		2.75	V
Input Voltage (5V tolerant inputs) ^(1,2)	V _{IN5Vtol}	-0.3		5.5	V
Input Voltage (non 5V tolerant inputs) ^(1,2)	V _{IN}	-0.3		3.6	V
Electrostatic Discharge	V _{ESD}			±2.0	kV
Latch-up	I _{LA}			±100	mA
Ambient Operating Temperature	T _A	0		70	°C
Storage Temperature	T _{STG}	-40		125	°C
Operating Junction Temp.	T _J	0		125	°C
Thermal Resistance (Junction to Air) Natural Convection ⁽³⁾					
gm5115	θ _{JA_5115}			32.4	°C/W
gm5125	θ _{JA_5125}			22.0	°C/W
Thermal Resistance (Junction to Case) Convection ⁽⁴⁾					
gm5115	θ _{JC_5115}			13.9	°C/W
gm5125	θ _{JC_5125}			10.1	°C/W
Soldering Temperature (30 sec.)	T _{SOL}			220	°C
Vapor Phase Soldering (30 sec.)	T _{VAP}			220	°C

NOTE (1): All voltages are measured with respect to GND

NOTE (2): Absolute maximum voltage ranges are for transient voltage excursions.

NOTE (3): Package thermal resistance is based on a PCB with one signal plane and two power planes. Package θ_{JA} is improved on a PCB with four or more layers

NOTE (4): Based on the figures for the Operating Junction Temperature, θ_{JC} and Power Consumption in Table 21, the typical case temperature is calculated as T_C = T_J - P₅₁₁₅ × θ_{JC}. This equals 104 degrees Celsius for gm5115 and 106 degrees Celsius for gm5125.

Table 21. DC Characteristics

PARAMETER	SYMBOL	MIN	TYP	MAX	UNITS
POWER					
Power Consumption @ 96 MHz (gm5115)	P_{5115}		1.5		W
Power Consumption @ 135 MHz (gm5125)	P_{5125}		1.8		W
Power Consumption @ Low Power Mode ⁽¹⁾	P_{LP}		0.15		W
3.3V Supply Voltages (AVDD and RVDD)	$V_{VDD_3.3}$	3.15	3.3	3.45	V
2.5V Supply Voltages (VDD and CVDD)	$V_{VDD_2.5}$	2.35	2.5	2.65	V
Supply Current @ CLK = 96 MHz (gm5115)	I_{5115}		400		mA
<ul style="list-style-type: none"> • 2.5V digital supply ⁽²⁾ • 2.5V analog supply ⁽³⁾ • 3.3V digital supply ⁽⁴⁾ • 3.3V analog supply ⁽⁵⁾ 	$I_{5115_2.5_VDD}$ $I_{5115_2.5_AVDD}$ $I_{5115_3.3_VDD}$ $I_{5115_3.3_AVDD}$			360 ⁽⁶⁾ 40 ⁽⁶⁾ 50 ⁽⁶⁾ 150 ⁽⁶⁾	
Supply Current @ CLK = 135MHz (gm5125)	I_{5125}		500		mA
<ul style="list-style-type: none"> • 2.5V digital supply ⁽²⁾ • 2.5V analog supply ⁽³⁾ • 3.3V digital supply ⁽⁴⁾ • 3.3V analog supply ⁽⁵⁾ 	$I_{5125_2.5_VDD}$ $I_{5125_2.5_AVDD}$ $I_{5125_3.3_VDD}$ $I_{5125_3.3_AVDD}$			500 ⁽⁶⁾ 50 ⁽⁶⁾ 60 ⁽⁶⁾ 150 ⁽⁶⁾	
Supply Current @ Low Power Mode*	I_{LP}		50		mA
INPUTS					
High Voltage	V_{IH}	2.0		V_{DD}	V
Low Voltage	V_{IL}	GND		0.8	V
Clock High Voltage	V_{IHC}	2.4		V_{DD}	V
Clock Low Voltage	V_{ILC}	GND		0.4	V
High Current ($V_{IN} = 5.0$ V)	I_{IH}	-25		25	μ A
Low Current ($V_{IN} = 0.8$ V)	I_{IL}	-25		25	μ A
Capacitance ($V_{IN} = 2.4$ V)	C_{IN}			8	pF
OUTPUTS					
High Voltage ($I_{OH} = 7$ mA)	V_{OH}	2.4		V_{DD}	V
Low Voltage ($I_{OL} = -7$ mA)	V_{OL}	GND		0.4	V
Tri-State Leakage Current	I_{OZ}	-25		25	μ A

NOTE (1): Low power figures result from setting the ADC, DVI, and clock power down bits so that only the micro-controller is running.

NOTE (2): Includes pins CVDD_2.5, VDD1_ADC_2.5, VDD2_ADC_2.5, VDD_RX0_2.5, VDD_RX1_2.5 and VDD_RX2_2.5.

NOTE (3): Includes only VDD_RXPLL_2.5.

NOTE (4): Includes pins VDD_DPLL, VDD_SDDS, VDD_DDDS and RVDD.

NOTE (5): Includes pins AVDD_RED, AVDD_GREEN, AVDD_BLUE, AVDD_IMB, AVDD_RX0, AVDD_RX1, AVDD_RX2, AVDD_RXC, AVDD_RPLL, AVDD_SDDS and AVDD_DDDS.

NOTE (6): Maximum current figures are provided for the purposes of selecting an appropriate power supply circuit.

5.2 Preliminary AC Characteristics

All timing is measured to a 1.5V logic-switching threshold. The minimum and maximum operating conditions used were: $T_{DIE} = 0$ to $125^{\circ}C$, $V_{DD} = 2.35$ to $2.65V$, Process = best to worst, $C_L = 16pF$ for all outputs.

Table 22. Maximum Speed of Operation

Clock Domain	Max Speed of Operation
Main Input Clock (TCLK)	24 MHz (14.3MHz recommended)
DVI Differential Input Clock	165 MHz
ADC Clock (ACLK)	162.5 MHz
HCLK Host Interface Clock (2-wire protocol)	5 MHz
Input Format Measurement Clock (IFM_CLK)	50MHz (14.3MHz recommended)
Reference Clock (RCLK)	200MHz (200MHz recommended)
On-Chip Microcontroller Clock (OCM_CLK)	100 MHz
Display Clock (DCLK)	135 MHz

Table 23. Display Timing and DCLK Adjustments

DP_TIMING ->	Tap 0 (default)		Tap 1		Tap 2		Tap 3	
	Min (ns)	Max (ns)	Min (ns)	Max (ns)	Min (ns)	Max (ns)	Min (ns)	Max (ns)
Propagation delay from DCLK to DA*/DB*	1.0	4.5	0.5	3.5	-0.5	2.5	-1.5	1.5
Propagation delay from DCLK to DHS	1.0	4.5	0.5	3.5	-0.5	2.5	-1.5	1.5
Propagation delay from DCLK to DVS	0.5	4.5	0.0	3.5	-1.0	2.5	-2.0	1.5
Propagation delay from DCLK to DEN	1.0	4.5	0.5	3.5	-0.5	2.5	-1.5	1.5

Note: DCLK Clock Adjustments are the amount of additional delay that can be inserted in the DCLK path, in order to reduce the propagation delay between DCLK and its related signals.

Table 24. 2-Wire Host Interface Port Timing

Parameter	Symbol	MIN	TYP	MAX	Units
SCL HIGH time	T_{SHI}	1.25			us
SCL LOW time	T_{SLO}	1.25			us
SDA to SCL Setup	T_{SDIS}	30			ns
SDA from SCL Hold	T_{SDIH}	20			ns
Propagation delay from SCL to SDA	T_{SDO3}	10		150	ns

Note: The above table assumes $OCM_CLK = R_CLK / 2 = 100$ MHz (default) (ie 10ns / clock)

6. ORDERING INFORMATION

Order Code	Application	Package	Temperature Range
gm5115	XGA	208-pin PQFP	0-70°C
gm5115-H ⁽¹⁾	XGA	208-pin PQFP	0-70°C
gm5125	SXGA	208-pin PQFP	0-70°C
gm5125-H ⁽¹⁾	SXGA	208-pin PQFP	0-70°C

Note (1): gm5115-H and gm5125-H versions will be sold only to HDCP-licensed customers.

7. MECHANICAL SPECIFICATIONS

Figure 32. gm5115/25 208-pin PQFP Mechanical Drawing

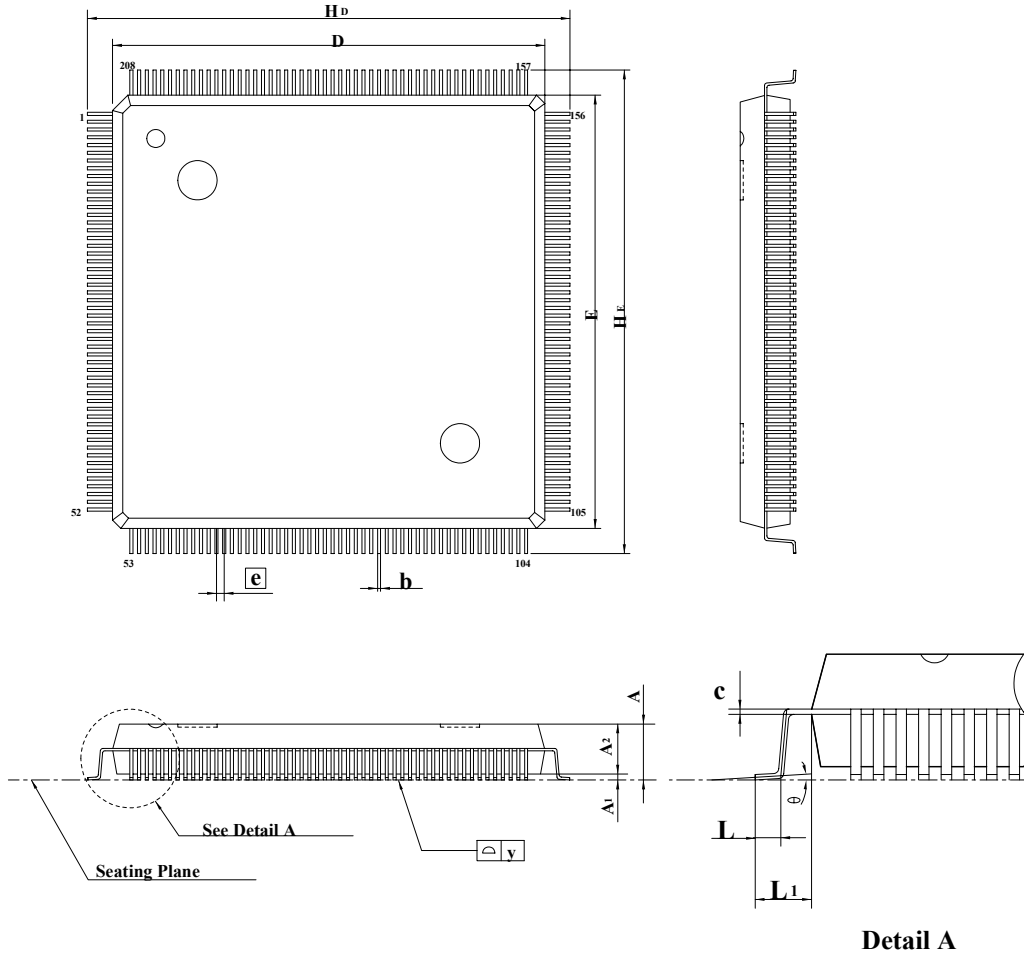

Symbol	Dimension in mm		
	Min	Nom	Max
A	3.92	—	4.07
A₁	0.25	—	—
A₂	3.15	3.23	3.30
b	0.18	—	0.28
c	0.13	—	0.23
D	27.90	28.00	28.10
E	27.90	28.00	28.10
[c]	0.50 BSC		
H_D	30.95	31.20	31.45
H_E	30.95	31.20	31.45
L	0.65	0.80	0.95
L₁	1.60 REF		
y	—	—	0.10
θ	0°	—	7°