

GM6201

CMOS Positive Voltage Regulator

Description

The GM6201 series are highly precise, low power consumption, positive voltage regulators manufactured using CMOS and laser trimming technologies.

The series provides large currents with a significantly small dropout voltage.

The GM6201 consists of a current limiter circuit, a driver transistor, a precision reference voltage and an error amplifier. Output voltage is selectable in 0.1V steps between 1.3 ~ 6.0v.

Features

- Maximum Output Current: 250mA (Typ.)
- Output Voltage Range: 1.3V ~ 6V (selectable in 0.1V steps)
- Low Power Consumption: Typ. 2.0uA
- Maximum Operating Voltage: 10V
- Dropout Voltage: 0.16V @I_{OUT}=100mA
- Highly Accurate: Output voltage ± 2%
- Capacitors can be Tantalum or Ceramic

Applications

- Battery Powered Equipment
- Mobile Phones and Cordless Phones
- Cameras and Video Recorders
- Portable Games and AV Equipment
- Reference Voltage

Package Dimensions

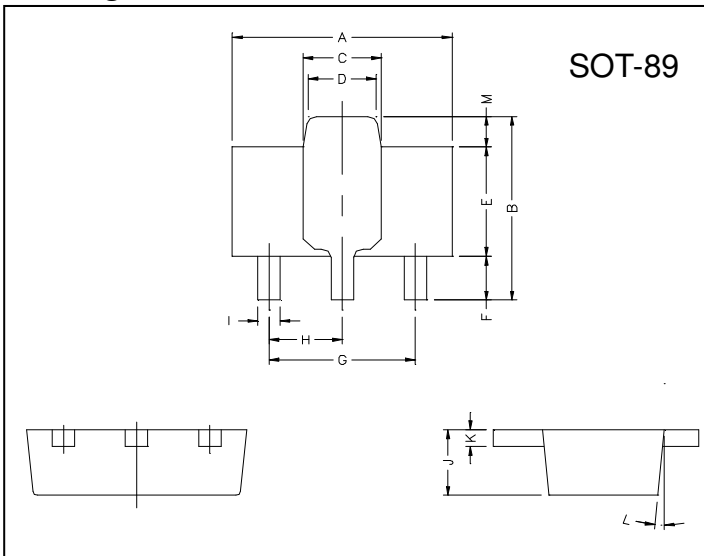

Marking :

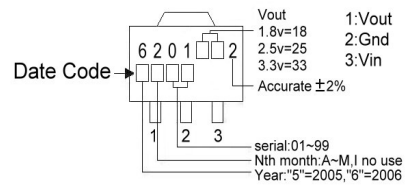

REF.	Millimeter		REF.	Millimeter	
	Min.	Max.		Min.	Max.
A	4.4	4.6	G	3.00	REF.
B	4.05	4.25	H	1.50	REF.
C	1.50	1.70	I	0.40	0.52
D	1.30	1.50	J	1.40	1.60
E	2.40	2.60	K	0.35	0.41
F	0.89	1.20	L	5° TYP.	
			M	0.70 REF.	

Typical Application Circuit

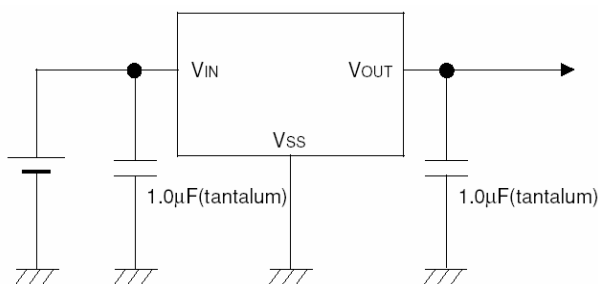

Block Diagram

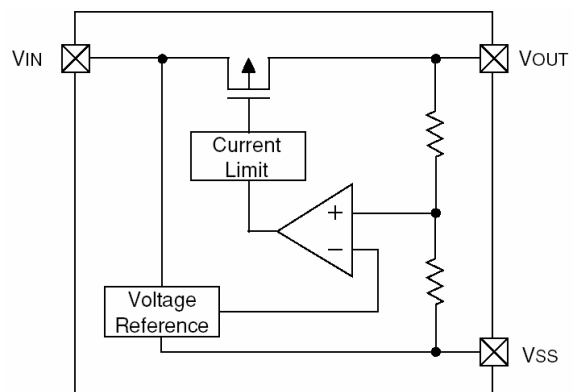

Absolute Maximum Ratings Ta=25°C

Parameter	Symbol	Ratings	Unit
Input Voltage	V _{IN}	12	V
Output Current	I _{OUT}	500	mA
Output Voltage	V _{OUT}	V _{SS} -0.3 ~V _{IN} +0.3	V
Operating Ambient Temperature	Topr	-40 ~ +85	°C
Storage Temperature	Tstg	-55 ~ +125	°C
Power Dissipation	PD	500	mW

Electrical Characteristics Ta=25°C**GM6201-50 V_{OUT} (T) =5.0V (Note1)**

Parameter	Symbol	Condition	Min	TYP	Max	Unit
Output Voltage	V _{OUT(E)} (Note2)	V _{IN} =6.0V, I _{OUT} =40mA	4.900	5.000	5.100	V
Max. Output Current	I _{OUT max}	V _{IN} =6V, V _{OUT(E)} ≥4.5V	200	-	-	mA
Load Regulation	ΔV _{OUT}	V _{IN} =6V, I _{OUT} =1mA to 100mA	-	30	70	mV
Dropout Voltage (Note3)	V _{dif1}	I _{OUT} =100mA	-	160	340	mV
	V _{dif2}	I _{OUT} =200mA	-	400	600	
Supply Current	I _{SS}	V _{IN} =6V	-	2.0	6.0	μA
Input Regulation	$\frac{\Delta V_{OUT}}{\Delta V_{IN} \cdot V_{OUT}}$	I _{OUT} =40mA V _{IN} =6V to 10V	-	0.2	0.3	%/V
Input Voltage	V _{IN}		1.8	-	10	V
Output Voltage Temperature Characteristics	$\frac{\Delta V_{OUT}}{\Delta Topr \cdot V_{OUT}}$	I _{OUT} =40mA -40°C ≤ Topr ≤ 85°C	-	±100	-	ppm/°C

Note 1: V_{OUT} (T) =Specified Output Voltage.

2: V_{OUT} (E) =Effective Output Voltage (i.e. the output voltage when "V_{OUT} (T) +1.0V" is provided while maintaining a certain I_{OUT} value).

3: V_{dif} ={V_{IN1} (Note5) -V_{OUT1} (Note4)}

4: V_{OUT1} =A voltage equal to 98% of the output voltage when a stabilized (V_{OUT} (T) + 1.0V) is output.

5: V_{IN1} =The input voltage at the time V_{OUT1} is output (input voltage has been gradually reduced).

GM6201-33 V_{OUT} (T) =3.3V (Note1)

Parameter	Symbol	Condition	Min	TYP	Max	Unit
Output Voltage	V _{OUT(E)} (Note2)	V _{IN} =4.3V, I _{OUT} =40mA	3.234	3.300	3.366	V
Max. Output Current	I _{OUT max}	V _{IN} =4.3V, V _{OUT(E)} ≥2.97V	150	-	-	mA
Load Regulation	ΔV _{OUT}	V _{IN} =4.3V, I _{OUT} =1mA to 80mA	-	20	50	mV
Dropout Voltage (Note3)	V _{dif1}	I _{OUT} =80mA	-	200	360	mV
	V _{dif2}	I _{OUT} =160mA	-	450	700	
Supply Current	I _{SS}	V _{IN} =4.3V	-	2.0	5.0	μA
Input Regulation	$\frac{\Delta V_{OUT}}{\Delta V_{IN} \cdot V_{OUT}}$	I _{OUT} =40mA V _{IN} =4.3V to 10V	-	0.2	0.3	%/V
Input Voltage	V _{IN}		1.8	-	10	V
Output Voltage Temperature Characteristics	$\frac{\Delta V_{OUT}}{\Delta Topr \cdot V_{OUT}}$	I _{OUT} =40mA -40°C ≤ Topr ≤ 85°C	-	±100	-	ppm/°C

GM6201-27 V_{OUT} (T) =2.7V (Note1)

Parameter	Symbol	Condition	Min	TYP	Max	Unit
Output Voltage	V _{OUT} (E) _(Note2)	V _{IN} =3.7V, I _{OUT} =40mA	2.646	2.700	2.754	V
Max. Output Current	I _{OUT max}	V _{IN} =3.7V, V _{OUT} (E)≥2.43V	100	-	-	mA
Load Regulation	ΔV _{OUT}	V _{IN} =3.7V, I _{OUT} =1mA to 60mA	-	15	40	mV
Dropout Voltage (Note3)	V _{dif1}	I _{OUT} =60mA	-	200	370	mV
	V _{dif2}	I _{OUT} =120mA	-	450	710	
Supply Current	I _{SS}	V _{IN} =3.7V	-	2.0	5.0	μA
Input Regulation	$\frac{\Delta V_{OUT}}{\Delta V_{IN} \cdot V_{OUT}}$	I _{OUT} =40mA V _{IN} =3.7V to 10V	-	0.2	0.3	%V
Input Voltage	V _{IN}		1.8	-	10	V
Output Voltage Temperature Characteristics	$\frac{\Delta V_{OUT}}{\Delta T_{opr} \cdot V_{OUT}}$	I _{OUT} =40mA -40°C ≤ T _{opr} ≤ 85°C	-	±100	-	ppm/°C

GM6201-18 V_{OUT} (T) =1.8V (Note1)

Parameter	Symbol	Condition	Min	TYP	Max	Unit
Output Voltage	V _{OUT} (E) _(Note2)	V _{IN} =2.8V, I _{OUT} =40mA	1.764	1.800	1.836	V
Max. Output Current	I _{OUT max}	V _{IN} =2.8V, V _{OUT} (E)≥1.62V	80	-	-	mA
Load Regulation	ΔV _{OUT}	V _{IN} =2.8V, I _{OUT} =1mA to 60mA	-	10	30	mV
Dropout Voltage (Note3)	V _{dif1}	I _{OUT} =40mA	-	200	370	mV
	V _{dif2}	I _{OUT} =80mA	-	450	710	
Supply Current	I _{SS}	V _{IN} =2.8V	-	3.0	5.0	μA
Input Regulation	$\frac{\Delta V_{OUT}}{\Delta V_{IN} \cdot V_{OUT}}$	I _{OUT} =40mA V _{IN} =2.8V to 10V	-	0.2	0.3	%V
Input Voltage	V _{IN}		1.8	-	10	V
Output Voltage Temperature Characteristics	$\frac{\Delta V_{OUT}}{\Delta T_{opr} \cdot V_{OUT}}$	I _{OUT} =40mA -40°C ≤ T _{opr} ≤ 85°C	-	±100	-	ppm/°C

GM6201-13 V_{OUT} (T) =1.3V (Note1)

Parameter	Symbol	Condition	Min	TYP	Max	Unit
Output Voltage	V _{OUT} (E) _(Note2)	V _{IN} =2.3V, I _{OUT} =40mA	1.274	1.300	1.326	V
Max. Output Current	I _{OUT max}	V _{IN} =2.3V, V _{OUT} (E)≥1.17V	60	-	-	mA
Load Regulation	ΔV _{OUT}	V _{IN} =2.3V, I _{OUT} =1mA to 30mA	-	10	30	mV
Dropout Voltage (Note3)	V _{dif1}	I _{OUT} =30mA	-	200	600	mV
	V _{dif2}	I _{OUT} =60mA	-	500	810	
Supply Current	I _{SS}	V _{IN} =2.3V	-	3.0	5.0	μA
Input Regulation	$\frac{\Delta V_{OUT}}{\Delta V_{IN} \cdot V_{OUT}}$	I _{OUT} =40mA V _{IN} =2.3V to 10V	-	0.2	0.3	%V
Input Voltage	V _{IN}		1.8	-	10	V
Output Voltage Temperature Characteristics	$\frac{\Delta V_{OUT}}{\Delta T_{opr} \cdot V_{OUT}}$	I _{OUT} =40mA -40°C ≤ T _{opr} ≤ 85°C	-	±100	-	ppm/°C

Test Circuit

Circuit1

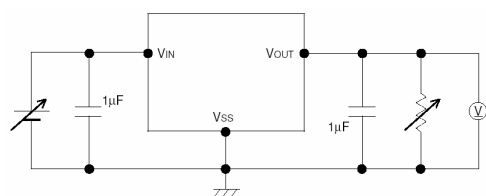

Circuit2

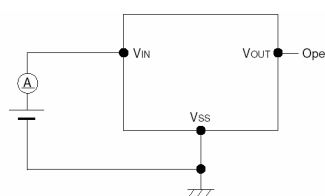

Characteristics Curve

(1) Output Voltage vs. Output Current

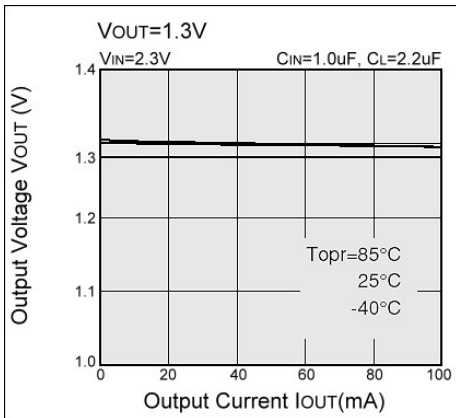
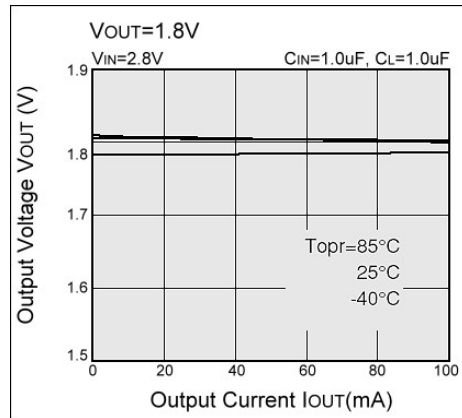
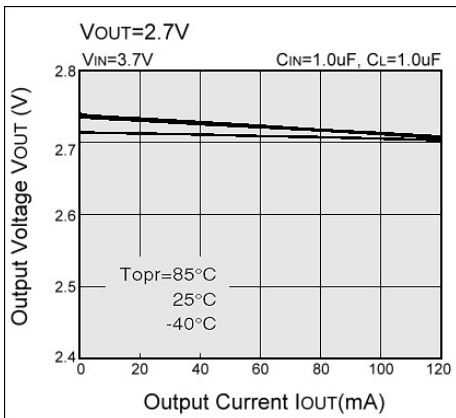
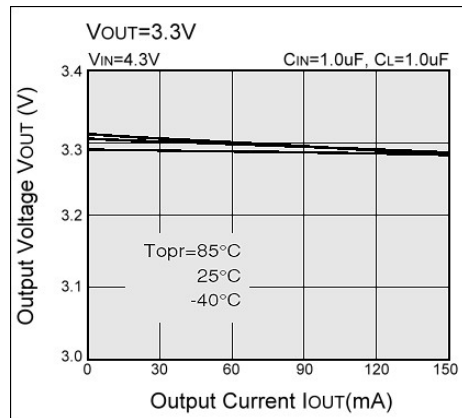
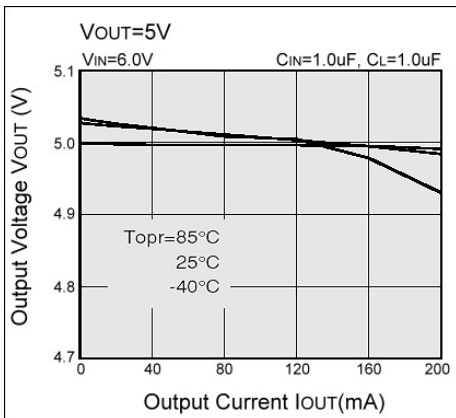

(2) Dropout Voltage vs. Output Current

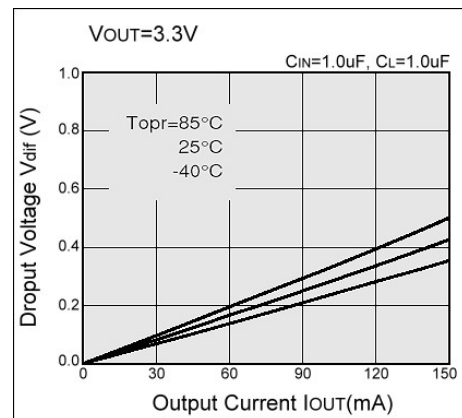
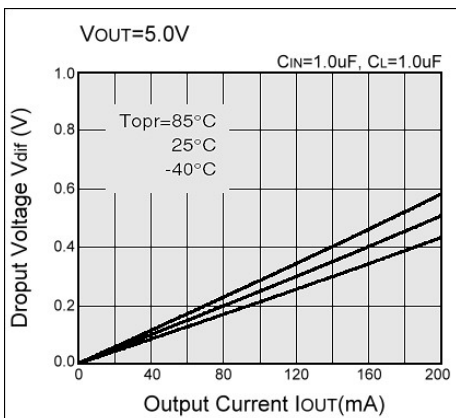

(2) Dropout Voltage vs. Output Current

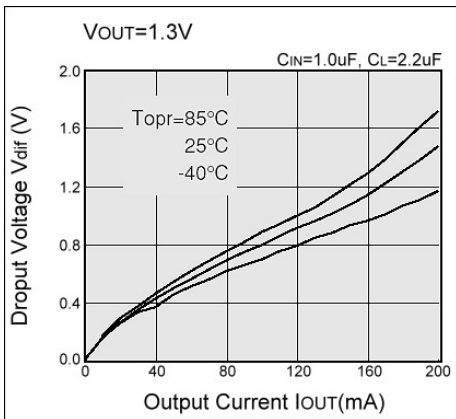
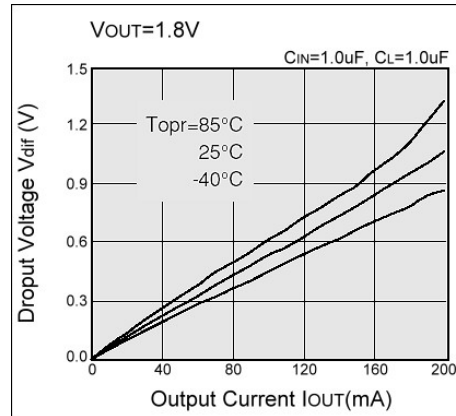
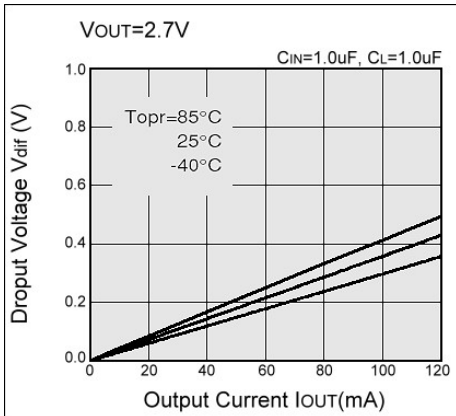

(3) Output Voltage vs. Input Voltage

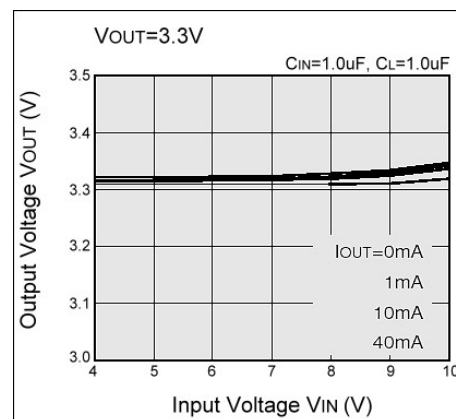
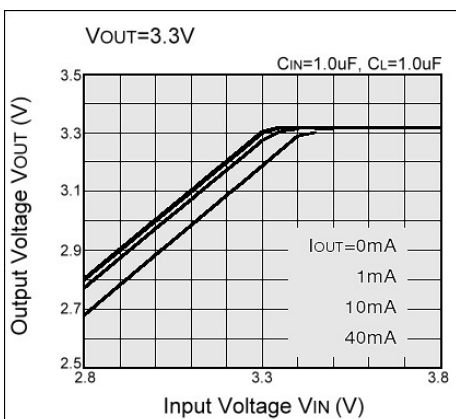
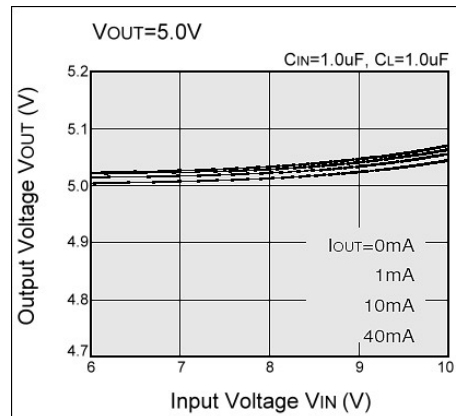
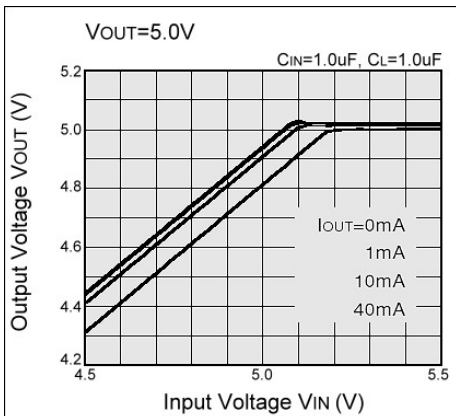

(3) Output Voltage vs. Input Voltage

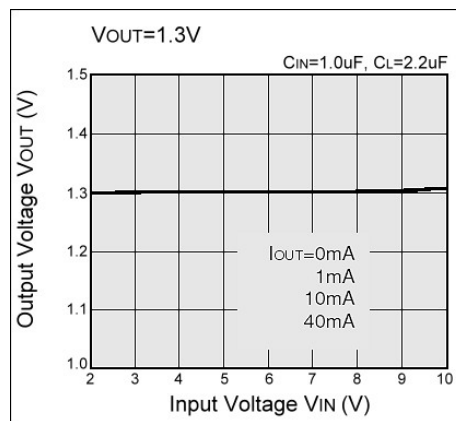
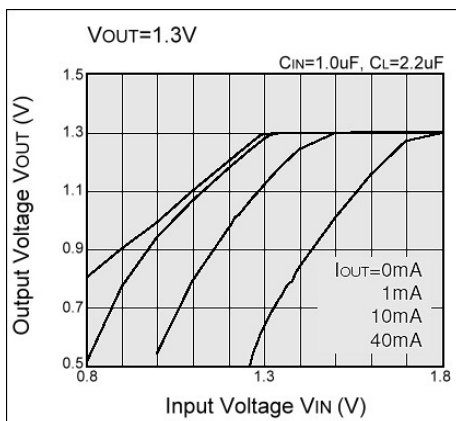
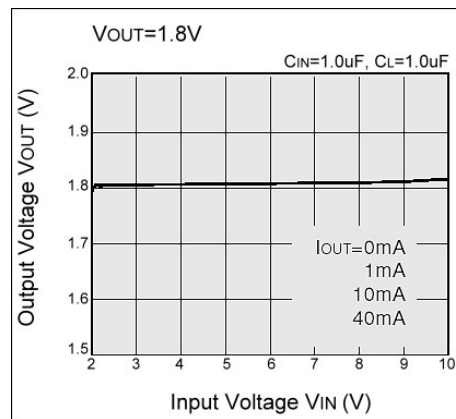
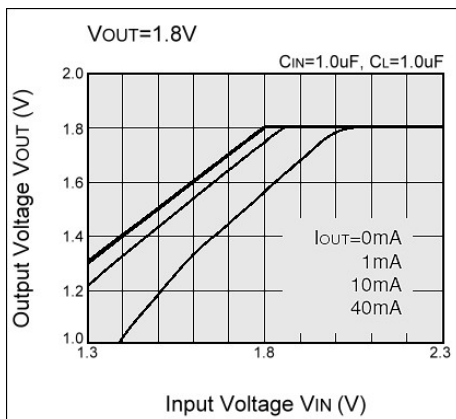
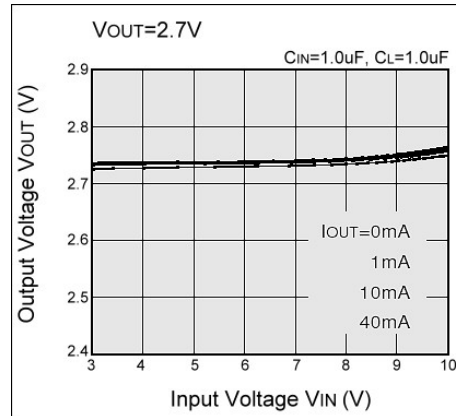
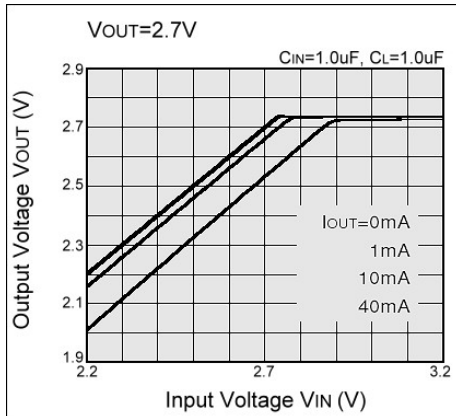

(4) Supply Current vs. Input Voltage

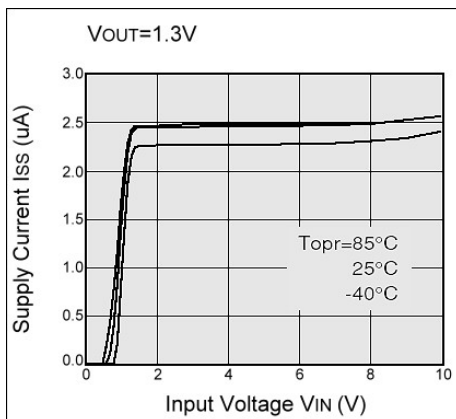
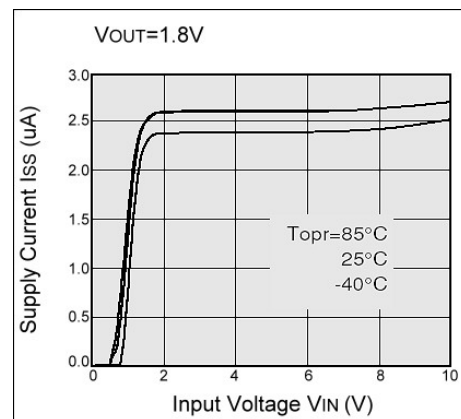
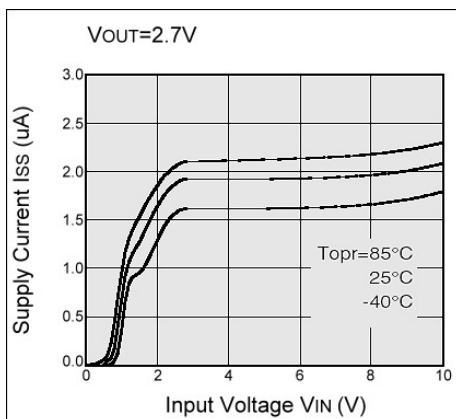
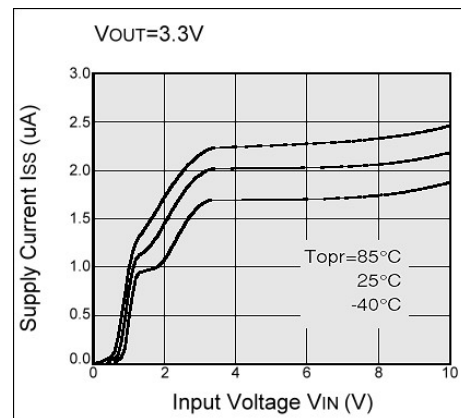
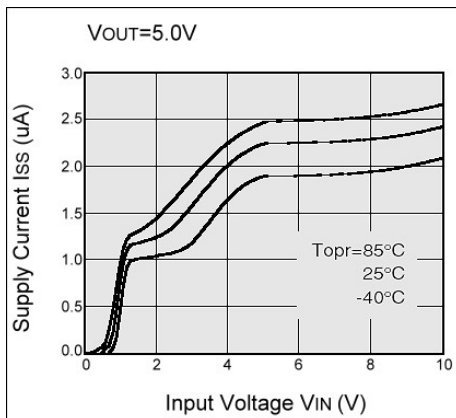

(5) Output Voltage vs. Ambient Temperature

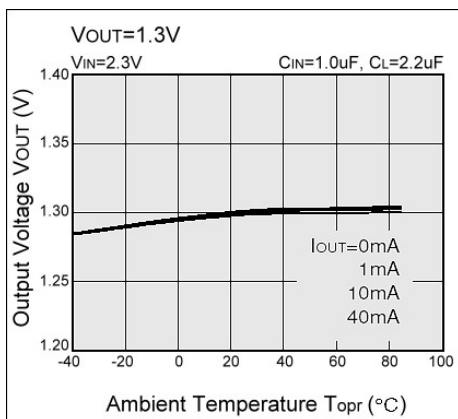
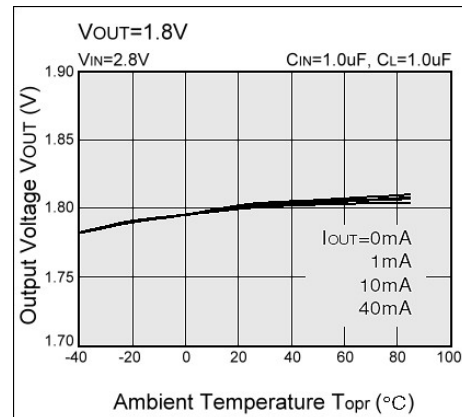
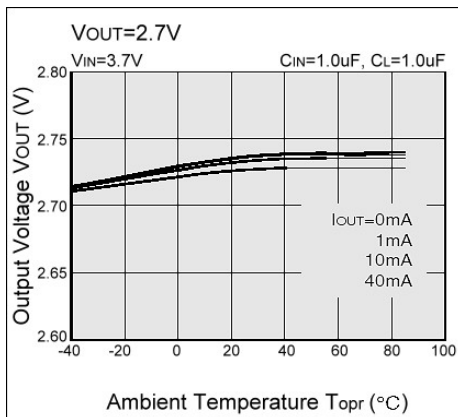
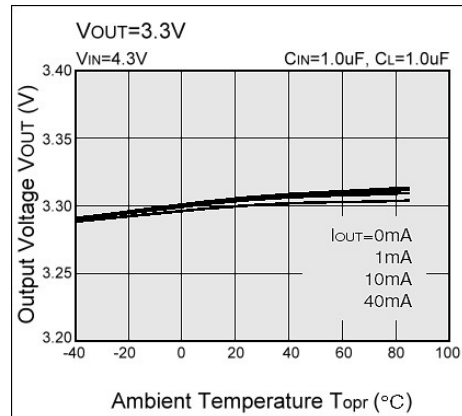
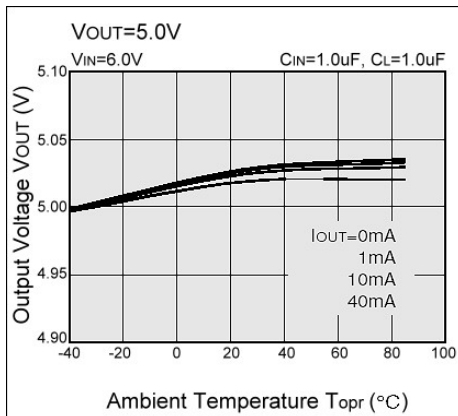

Important Notice:

- All rights are reserved. Reproduction in whole or in part is prohibited without the prior written approval of GTM.
- GTM reserves the right to make changes to its products without notice.
- GTM semiconductor products are not warranted to be suitable for use in life-support Applications, or systems.
- GTM assumes no liability for any consequence of customer product design, infringement of patents, or application assistance.

Head Office And Factory:

- **Taiwan:** No. 17-1 Tatung Rd. Fu Kou Hsin-Chu Industrial Park, Hsin-Chu, Taiwan, R. O. C.
- TEL : 886-3-597-7061 FAX : 886-3-597-9220, 597-0785
- **China:** (201203) No.255, Jang-Jiang Tsai-Lueng RD. , Pu-Dung-Hsin District, Shang-Hai City, China
- TEL : 86-21-5895-7671 ~ 4 FAX : 86-21-38950165