

Document Title**32K x8 bit 5.0V Low Power CMOS slow SRAM**Revision History

| <u>Revision No</u> | <u>History</u> | <u>Draft Date</u> | <u>Remark</u> |
|--------------------|---|-------------------|---------------|
| 00 | Revision History Insert Revised - Datasheet format change - PDIP package type insert - Pin configuration change | Jul.07.2000 | Final |
| 01 | Revised - tWP Value Change @55ns : 45ns -> 40ns | Nov.28.2000 | Final |
| 02 | Marking Information Add Revised - AC Test Condition Add : 5pF Test Load - tCLZ Value Change : 5ns -> 10ns | Dec.04.2000 | Final |
| 03 | Changed Logo - HYUNDAI -> hynix | Apr.30.2001 | Final |

DESCRIPTION

The GM76C256C is a high-speed, low power and 32,786 X 8-bits CMOS Static Random Access Memory fabricated using Hynix's high performance CMOS process technology. It is suitable for use in low voltage operation and battery back-up application. This device has a data retention mode that guarantees data to remain valid at the minimum power supply voltage of 2.0 volt.

FEATURES

- Fully static operation and Tri-state output
- TTL compatible inputs and outputs
- Low power consumption
- Battery backup(L/LL-part)
 - 2.0V(min.) data retention
- Standard pin configuration
 - 28 pin 600mil PDIP
 - 28 pin 330mil SOP
 - 28 pin 8x13.4 mm TSOP-I (Standard)

| Product No. | Voltage (V) | Speed (ns) | Operation Current(mA) | Standby Current(uA) | | Temperature (°C) |
|-------------|-------------|------------|-----------------------|---------------------|----|------------------|
| | | | | L | LL | |
| GM76C256C | 5.0 | 55/70/85 | 10 | 40 | 20 | 0~70(Normal) |
| GM76C256CE | 5.0 | 55/70/85 | 10 | 60 | 30 | -25~85(Extended) |

Note 1. Current value is max.

PIN CONNECTION

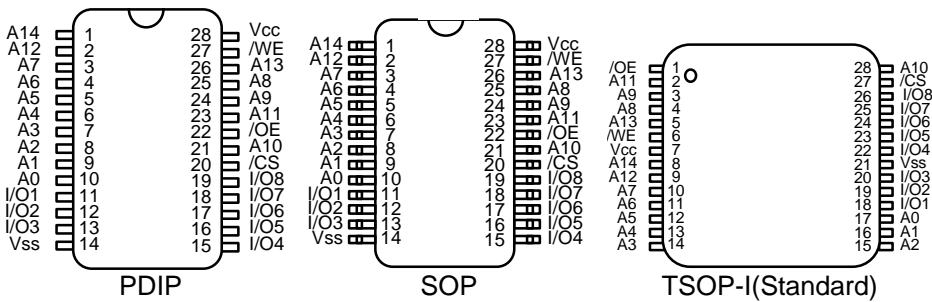

PIN DESCRIPTION

| Pin Name | Pin Function |
|-------------|-------------------|
| /CS | Chip Select |
| /WE | Write Enable |
| /OE | Output Enable |
| A0 ~ A14 | Address Inputs |
| I/O1 ~ I/O8 | Data Input/Output |
| Vcc | Power(+5.0V) |
| Vss | Ground |

BLOCK DIAGRAM

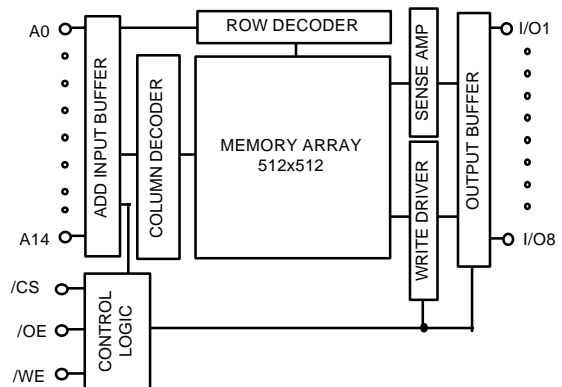

ORDERING INFORMATION

| Part No. | Speed | Power | Temp | Package |
|----------------|----------|---------|-------------|-----------------|
| GM76C256CL | 55/70/85 | L-part | 0 to 70°C | PDIP |
| GM76C256CLL | 55/70/85 | LL-part | 0 to 70°C | PDIP |
| GM76C256CLE | 55/70/85 | L-part | -25 to 85°C | PDIP |
| GM76C256CLLE | 55/70/85 | LL-part | -25 to 85°C | PDIP |
| GM76C256CLFW | 55/70/85 | L-part | 0 to 70°C | SOP |
| GM76C256CLLFW | 55/70/85 | LL-part | 0 to 70°C | SOP |
| GM76C256CLEFW | 55/70/85 | L-part | -25 to 85°C | SOP |
| GM76C256CLLEFW | 55/70/85 | LL-part | -25 to 85°C | SOP |
| GM76C256CLT | 55/70/85 | L-part | 0 to 70°C | TSOP-I Standard |
| GM76C256CLLT | 55/70/85 | LL-part | 0 to 70°C | TSOP-I Standard |
| GM76C256CLET | 55/70/85 | L-part | -25 to 85°C | TSOP-I Standard |
| GM76C256CLET | 55/70/85 | LL-part | -25 to 85°C | TSOP-I Standard |

ABSOLUTE MAXIMUM RATING (1)

| Symbol | Parameter | Rating | Unit |
|--|------------------------------------|-------------|-----------|
| V _{CC} , V _{IN} , V _{OUT} | Power Supply, Input/Output Voltage | -0.3 to 7.0 | V |
| T _A | Operating Temperature | GM76C256C | 0 to 70 |
| | | GM76C256CE | -25 to 85 |
| T _{STG} | Storage Temperature | -65 to 150 | °C |
| P _d | Power Dissipation | 1.0 | W |
| I _{OUT} | Data Output Current | 50 | mA |
| T _{SDLER} | Lead Soldering Temperature & Time | 260 •10 | °C•sec |

Note

- Stresses greater than those listed under ABSOLUTE MAXIMUM RATINGS may cause permanent damage to the device. This is stress rating only and the functional operation of the device under these or any other conditions above those indicated in the operation of this specification is not implied. Exposure to the absolute maximum rating conditions for extended period may affect reliability.

RECOMMENDED DC OPERATING CONDITIONS

| Symbol | Parameter | Min. | Typ. | Max. | Unit |
|-----------------|----------------------|---------|------|----------------------|------|
| V _{CC} | Power Supply Voltage | 4.5 | 5.0 | 5.5 | V |
| V _{SS} | Ground | 0 | 0 | 0 | V |
| V _{IH} | Input High Voltage | 2.2 | - | V _{CC} +0.3 | V |
| V _{IL} | Input Low Voltage | -0.3(1) | - | 0.8 | V |

Note

- V_{IL} = -3.0V for pulse width less than 50ns

TRUTH TABLE

| /CS | /WE | /OE | Mode | I/O Operation |
|-----|-----|-----|-----------------|---------------|
| H | X | X | Standby | High-Z |
| L | H | H | Output Disabled | High-Z |
| L | H | L | Read | Data Out |
| L | L | X | Write | Data In |

Note

- H=V_{IH}, L=V_{IL}, X=Don't Care

DC CHARACTERISTICS

V_{CC} = 5V ±10%, T_A = 0°C to 70°C (Normal)/-25°C to 85°C (Extended), unless otherwise specified.

| Symbol | Parameter | Test Condition | Min. | Typ. | Max. | Unit | |
|------------------|------------------------------------|--|------|------|------|------|----|
| I _{LI} | Input Leakage Current | V _{SS} ≤ V _{IN} ≤ V _{CC} | -1 | - | 1 | μA | |
| I _{LO} | Output Leakage Current | V _{SS} ≤ V _{OUT} ≤ V _{CC} , /CS = V _{IH} or /OE = V _{IH} or /WE = V _{IL} | -1 | - | 1 | μA | |
| I _{CC} | Operating Power Supply Current | /CS = V _{IL} , V _{IN} = V _{IH} or V _{IL} , V _{IN} = V _{IH} or V _{IL} , I _{I/O} = 0mA | - | - | 10 | mA | |
| I _{CC1} | Average Operating Current | /CS = V _{IL} , V _{IN} = V _{IH} or V _{IL} , Min. Duty Cycle = 100%, I _{I/O} = 0mA | - | - | 70 | mA | |
| I _{SB} | TTL Standby Current (TTL Inputs) | /CS = V _{IH} V _{IN} = V _{IH} or V _{IL} | - | - | 1 | mA | |
| I _{SB1} | CMOS Standby Current (CMOS Inputs) | /CS ≥ V _{CC} - 0.2V, V _{IN} ≥ V _{CC} - 0.2V or V _{IN} ≤ V _{SS} + 0.2V | L | - | - | 40 | μA |
| | | | LL | - | - | 20 | μA |
| | | | LE | - | - | 60 | μA |
| | | | LLE | - | - | 30 | μA |
| V _{OL} | Output Low Voltage | I _{OL} = 2.1mA | - | - | 0.4 | V | |
| V _{OH} | Output High Voltage | I _{OH} = -1.0mA | 2.4 | - | - | V | |

Note : Typical values are at V_{CC} = 5.0V, T_A = 25°C

AC CHARACTERISTICS(I)

V_{CC} = 5V ±10%, T_A = 0°C to 70°C (Normal) / -25°C to 85°C (Extended) unless otherwise specified.

| # | Symbol | Parameter | -55 | | -70 | | -85 | | Unit |
|--------------------|------------------|----------------------------------|------|------|------|------|-----|------|------|
| | | | Min. | Max. | Min. | Max. | Min | Max. | |
| READ CYCLE | | | | | | | | | |
| 1 | t _{RC} | Read Cycle Time | 55 | - | 70 | - | 85 | - | ns |
| 2 | t _{AA} | Address Access Time | - | 55 | - | 70 | - | 85 | ns |
| 3 | t _{ACS} | Chip Select Access Time | - | 55 | - | 70 | - | 85 | ns |
| 4 | t _{OE} | Output Enable to Output Valid | - | 30 | - | 35 | - | 45 | ns |
| 5 | t _{CLZ} | Chip Select to Output in Low Z | 10 | - | 10 | - | 10 | - | ns |
| 6 | t _{OLZ} | Output Enable to Output in Low Z | 5 | - | 5 | - | 5 | - | ns |
| 7 | t _{CHZ} | Chip Disable to Output in High Z | 0 | 20 | 0 | 30 | 0 | 30 | ns |
| 8 | t _{OHZ} | Out Disable to Output in High Z | 0 | 20 | 0 | 30 | 0 | 30 | ns |
| 9 | t _{OH} | Output Hold from Address Change | 5 | - | 5 | - | 5 | - | ns |
| WRITE CYCLE | | | | | | | | | |
| 10 | t _{WC} | Write Cycle Time | 55 | - | 70 | - | 85 | - | ns |
| 11 | t _{CW} | Chip Selection to End of Write | 50 | - | 65 | - | 75 | - | ns |
| 12 | t _{AW} | Address Valid to End of Write | 50 | - | 65 | - | 75 | - | ns |
| 13 | t _{AS} | Address Set-up Time | 0 | - | 0 | - | 0 | - | ns |
| 14 | t _{WP} | Write Pulse Width | 40 | - | 50 | - | 60 | - | ns |
| 15 | t _{WR} | Write Recovery Time | 0 | - | 0 | - | 0 | - | ns |
| 16 | t _{WHZ} | Write to Output in High Z | 0 | 20 | 0 | 25 | 0 | 30 | ns |
| 17 | t _{DW} | Data to Write Time Overlap | 25 | - | 30 | - | 40 | - | ns |
| 18 | t _{DH} | Data Hold from Write Time | 0 | - | 0 | - | 0 | - | ns |
| 19 | t _{OW} | Output Active from End of Write | 5 | - | 5 | - | 5 | - | ns |

AC TEST CONDITIONS

TA = 0°C to 70°C (Normal) / -25°C to 85°C (Extended) unless otherwise specified.

| Parameter | | Value |
|---|------------------------------|------------------------|
| Input Pulse Level | | 0.8V to 2.4V |
| Input Rise and Fall Time | | 5ns |
| Input and Output Timing Reference Level | | 1.5V |
| Output Load | tCLZ,tOLZ,tCHZ,tOHZ,tWHZ,tOW | CL = 5pF + 1TTL Load |
| | Others | CL = 100pF + 1TTL Load |

AC TEST LOADS

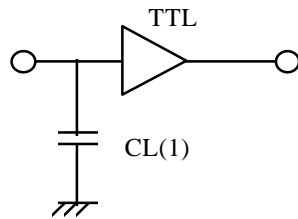

Note : Including jig and scope capacitance

CAPACITANCE

TA = 25°C, f = 1.0MHz

| Symbol | Parameter | Condition | Max. | Unit |
|--------|---------------------------|------------|------|------|
| CIN | Input Capacitance | VIN = 0V | 6 | pF |
| C/O | Input /Output Capacitance | V/I/O = 0V | 8 | pF |

Note : These parameters are sampled and not 100% tested

TIMING DIAGRAM

READ CYCLE 1

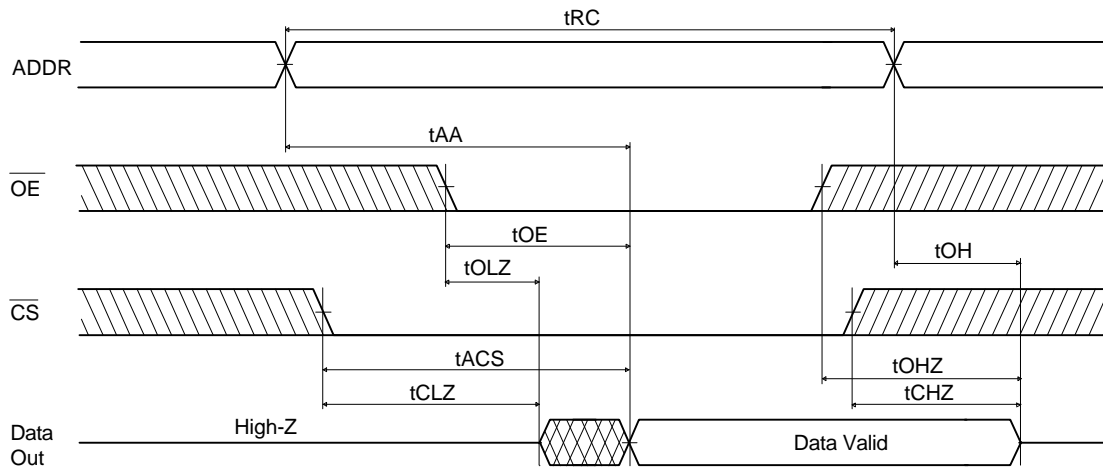

Note(READ CYCLE):

1. t_{CHZ} and t_{OHZ} are defined as the time at which the outputs achieve the open circuit conditions and are not referenced to output voltage levels.
2. At any given temperature and voltage condition, t_{CHZ} max. is less than t_{CLZ} min. both for a given device and from device to device.
3. \overline{WE} is high for the read cycle.

READ CYCLE 2

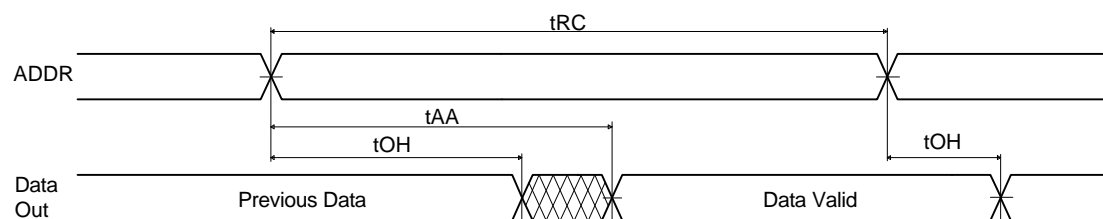

Note(READ CYCLE):

1. \overline{WE} is high for the read cycle.
2. Device is continuously selected $\overline{CS} = V_{IL}$.
3. $\overline{OE} = V_{IL}$.

WRITE CYCLE 1 (/OE Clocked)

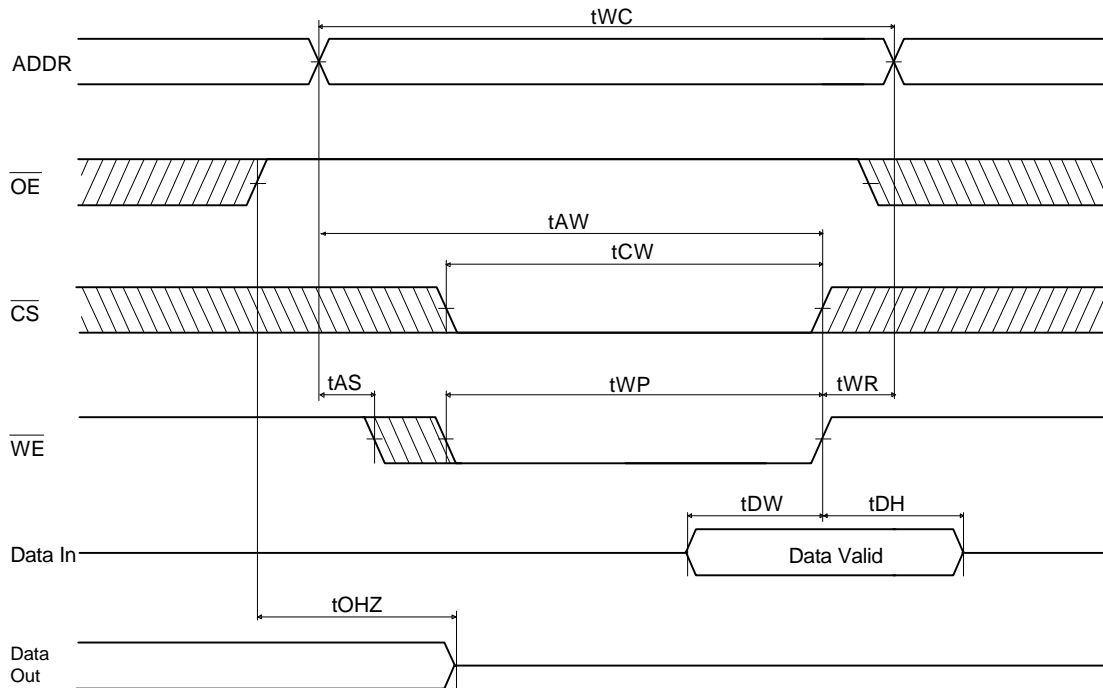

WRITE CYCLE 2 (/OE Low Fixed)

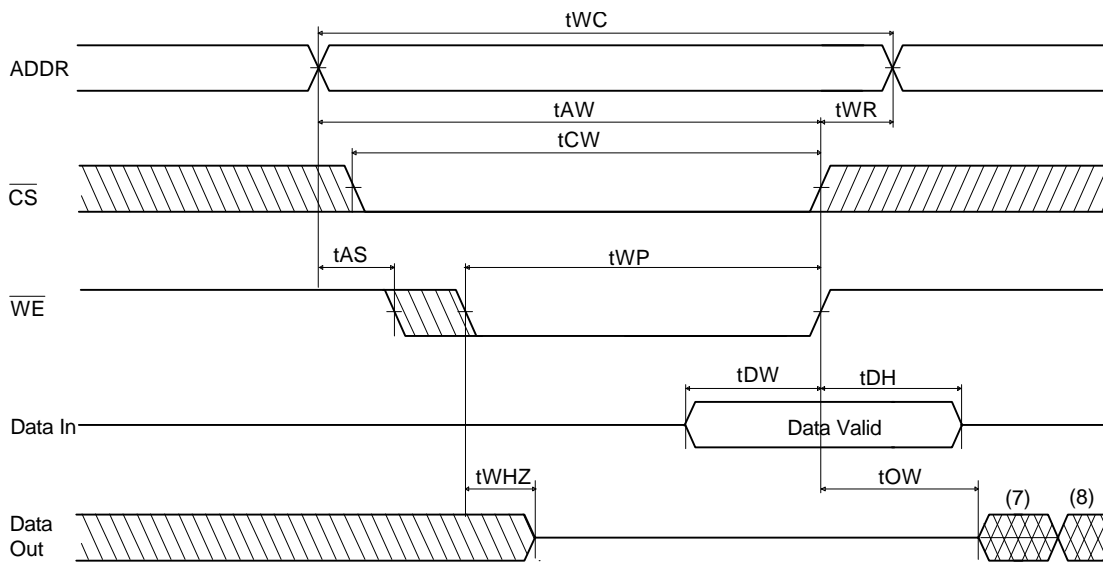

Notes(WRITE CYCLE):

1. A write occurs during the overlap of a low /CS and a low /WE. A write begins at the latest transition among /CS going low and /WE going low: A write ends at the earliest transition among /CS going high and /WE going high. tWP is measured from the beginning of write to the end of write.
2. tcw is measured from the later of /CS going low to the end of write .
3. tAS is measured from the address valid to the beginning of write.
4. tWR is measured from the end of write to the address change. tWR is applied in case a write ends as /CS, or /WE going high.
5. If /OE and /WE are in the read mode during this period, and the I/O pins are in the output low-Z state, input of opposite phase of the output must not be applied because bus contention can occur.
6. If /CS goes low simultaneously with /WE going low, or after /WE going low, the outputs remain in high impedance state.
7. DOUT is the same phase of the latest written data in this write cycle.
8. DOUT is the read data of the new address.

DATA RETENTION CHARACTERISTIC

TA = 0°C to 70°C (Normal) / -25°C to 85°C (Extended) unless otherwise specified.

| Symbol | Parameter | Test Condition | Min | Typ | Max | Unit | |
|--------|--------------------------------------|---|--------|-----|-----|------|----|
| VDR | Vcc for Data Retention | CS ≥ Vcc-0.2V, VIN ≥ Vcc - 0.2V or VIN ≤ Vss + 0.2V | 2.0 | - | - | V | |
| ICCDR | Data Retention Current | Vcc=3.0V, /CS ≥ Vcc - 0.2V, VIN ≥ Vcc - 0.2V or VIN ≤ Vss + 0.2V | L | - | 1 | 15 | uA |
| | | | LL | - | 0.5 | 7 | uA |
| | | | LE | - | 1 | 20 | uA |
| | | | LLE | - | 0.5 | 10 | uA |
| tCDR | Chip Deselect to Data Retention Time | See Data Retention | 0 | - | - | ns | |
| tR | Operating Recovery Time | Timing Diagram | tRC(2) | - | - | ns | |

Notes

1. Typical values are under the condition of TA = 25 °C.
2. tRC is read cycle time.

DATA RETENTION TIMING DIAGRAM

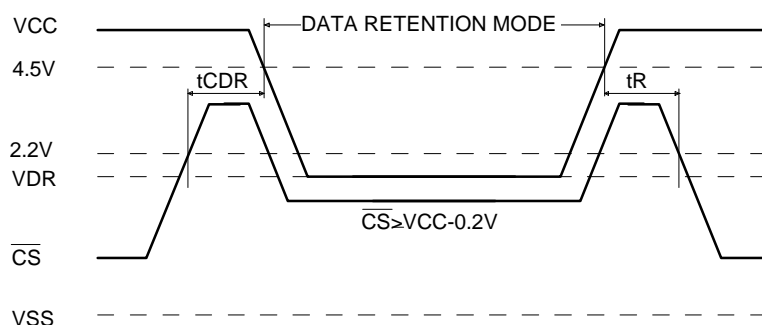

28pin 8x13.4mm Thin Small Outline Package Standard(T)

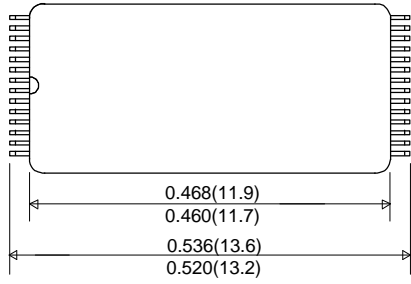

UNIT : INCH(mm) ^{MAX.}/_{MIN.}

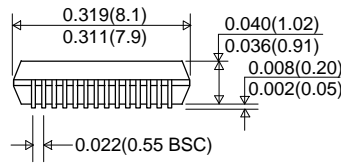
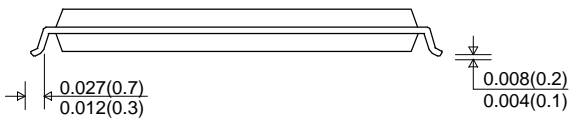

MARKING INFORMATION

| Package | Marking Example |
|---------------|-----------------|
| <p>PDIP</p> | |
| <p>SOP</p> | |
| <p>TSOP-I</p> | |

| Index | |
|---|---|
| <ul style="list-style-type: none"> • HYUNDAI • KOREA • GM76C256C • cc | <ul style="list-style-type: none"> : Hynix Logo : Origin Country : Part Name : Power Consumption <ul style="list-style-type: none"> - L : Low Power - LL : Low Low Power |
| <ul style="list-style-type: none"> • Blank / FW / T | <ul style="list-style-type: none"> : Package Type <ul style="list-style-type: none"> - Blank : DIP - FW : SOP - T : TSOP-I |
| <ul style="list-style-type: none"> • ss | <ul style="list-style-type: none"> : Speed <ul style="list-style-type: none"> - 55 : 55ns - 70 : 70ns |
| <ul style="list-style-type: none"> • t | <ul style="list-style-type: none"> : Temperature <ul style="list-style-type: none"> - Blank : Commercial (0 ~ 70 °C) - E : Extended (-25 ~ 85 °C) |
| <ul style="list-style-type: none"> • yy • ww | <ul style="list-style-type: none"> : Year (ex : 00 = year 2000, 01 = year 2001) : Work Week (ex : 12 = ww12) |
| <p>Note</p> <ul style="list-style-type: none"> - Capital Letter - Small Letter | <ul style="list-style-type: none"> : Fixed Item : Non-fixed Item |