

Description

THE GM78R09 is a low - dropout voltage regulator suitable for various electronic equipments. It provides constant voltage power source with TO-220 4 lead full mold package. Dropout voltage of GM78R09 is below 0.5V in full rated current (1A). This regulator has various function such as peak current protection, thermal shut down, overvoltage protection and output disable function.

Features

- ◆ 1A / 9V Output low dropout voltage regulator
- ◆ TO-220 Full-Mold package (4PIN)
- ◆ Overcurrent protection, Thermal shutdown
- ◆ Overvoltage protection, Short-Circuit Protection
- ◆ With output disable function

TYPIC APPLICATION CIRCUITS

TO-220F- 4L

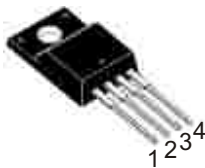

1. V_{IN}
2. V_O
3. GND
4. V_{DIS}

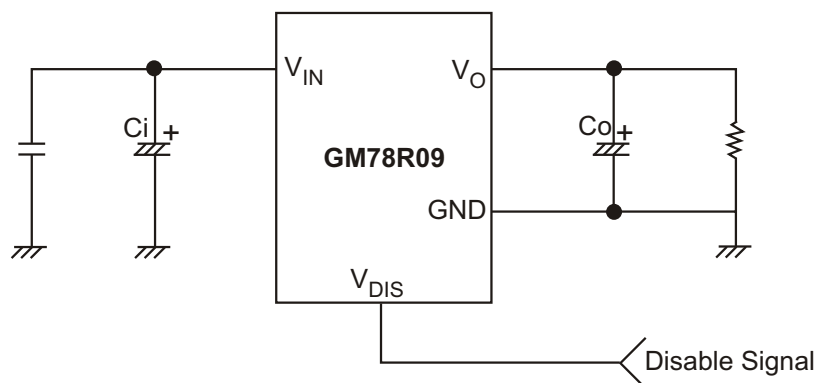

C_i is required if regulator is located an appreciable distance from power supply filter. C_o improves stability and transient response. ($C_o > 47\mu F$)

◆ PIN CONFIGURATIONS

TO - 220F - 4L

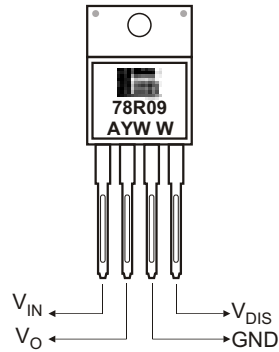

A : Assemble Location
Y : Year
WW : Work Week

◆ ORDERING INFORMATION

Ordering Number	Package	Shipping
GM78R09-TBF4T	TO - 220F-4L	50 Units/ Tube

◆ ABSOLUTE MAXIMUM RATINGS (limiting values, per diode)

Symbol	Parameter	Value	Unit	Remark
V_{IN}	Input Voltage	35	V	-
V_{DIS}	Disable Voltage	35	V	-
I_O	Output Current	1.0	A	-
P_{d1}	Power Dissipation 1	1.5	W	No Heatsink
P_{d2}	Power Dissipation 2	15	W	Whit Heatsink
T_J	Junction Temperature	+150	°C	-
T_{OPR}	Operating Temperature	-20 ~ +80	°C	-
$R_{\theta JC}$	Thermal Resistance, Junction - to Case (Note 2)	4.31	°C/W	-
$R_{\theta JA}$	Thermal Resistance, Junction - to Air (Note 2)	48.83	°C/W	-
T_{tsd}	Thermal Shutdown Temperature	150	°C	-

◆ **Electrical Characteristics** ($V_{IN} = 11V$, $I_O = 0.5A$, $T_A = 25^\circ C$, unless otherwise specified)

Parameter	Symbol	Conditions	Min.	Typ.	Max.	Unit
Output Voltage	V_O	-	8.78	9	9.22	V
Load Regulation	R_{load}	$5mA < I_O < 1A$	-	0.1	2.0	%
Line Regulation	R_{line}	$10V < V_{IN} < 25V$	-	0.5	2.5	%
Ripple Rejection Ratio	RR	Note 1	45	55	-	dB
Dropout Voltage	V_{drop}	$I_O = 1A$	-	-	0.5	V
Disable Voltage High	V_{disH}	Output Active	2.4	-	-	V
Disable Voltage Low	V_{disL}	Output Disabled	-	-	0.8	V
Disable Bias Current High	I_{disH}	$V_{dis} = 2.7V$	-	-	20	μA
Disable Bias Current Low	I_{disL}	$V_{dis} = 0.4V$	-	-	-0.4	mA
Quiescent Current	I_Q	$I_O = 0A$	-	-	10	mA

Note:

1. These parameters, although guaranteed, are not 100% tested in production.
2. Junction - to - case thermal resistance test environments.
 - Pneumatic heat sink fixture.
 - Clamping pressure 60psi through 12mm diameter cylinder.
 - Thermal grease applied between PKG and heat sink fixture.

◆ **BLOCK DIAGRAM(POSITIVE LOGIC)**

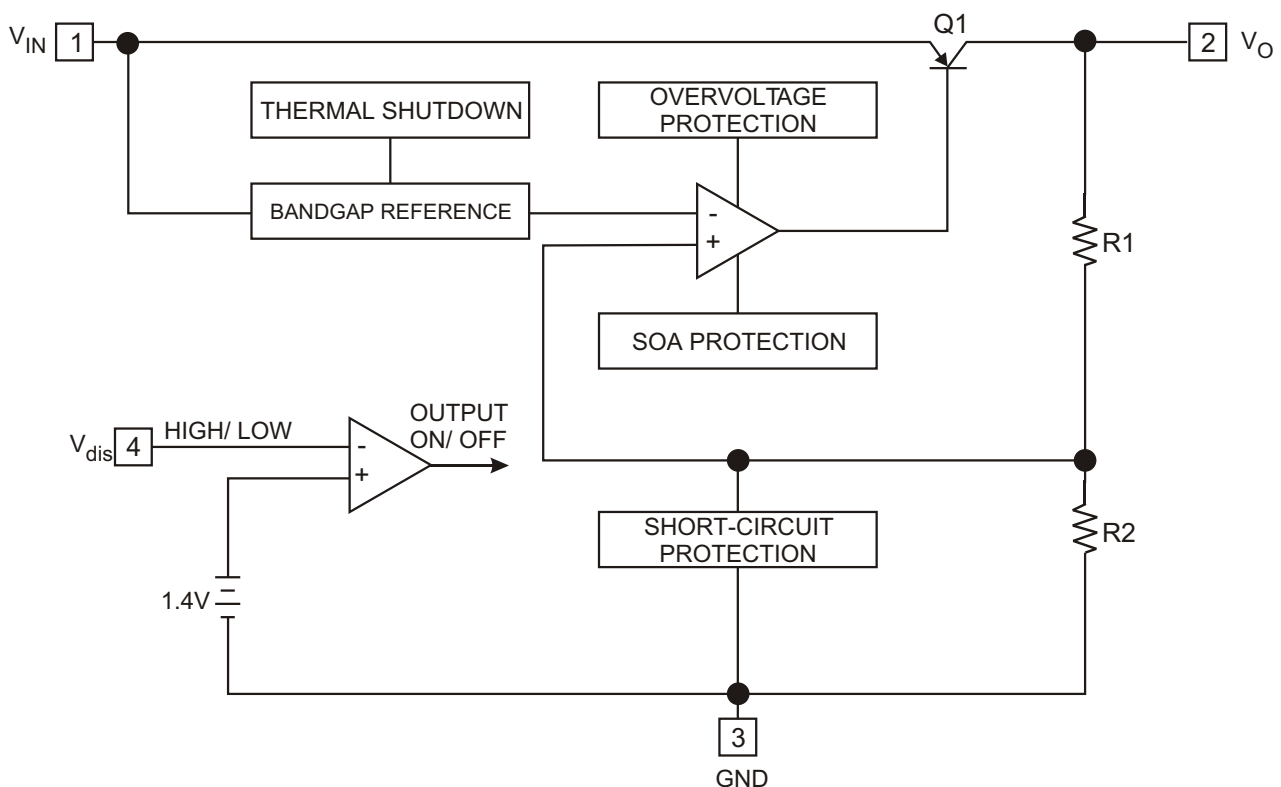

◆ TYPICAL PERFORMANCE CHARACTERISTICS

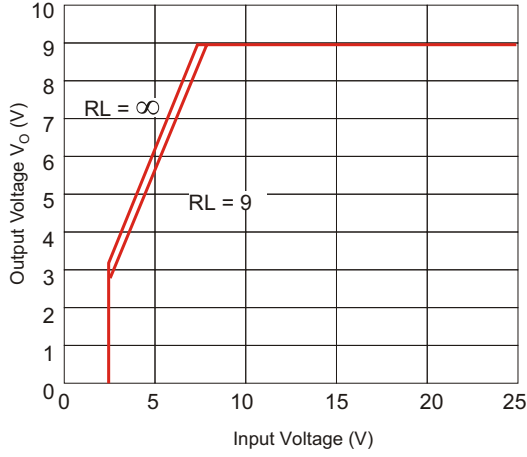

Figure 1. Output Voltage vs. Input Voltage

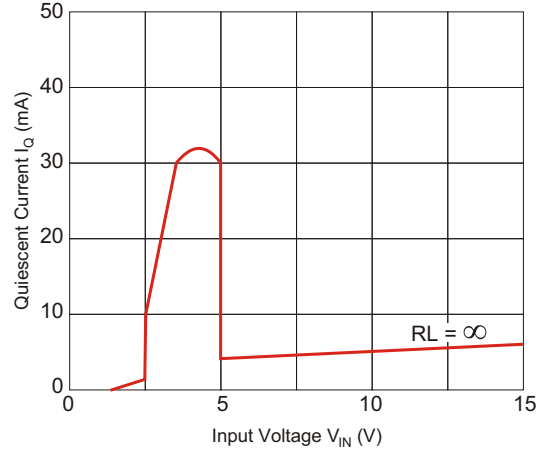

Figure 2. Quiescent Current vs. Input Voltage

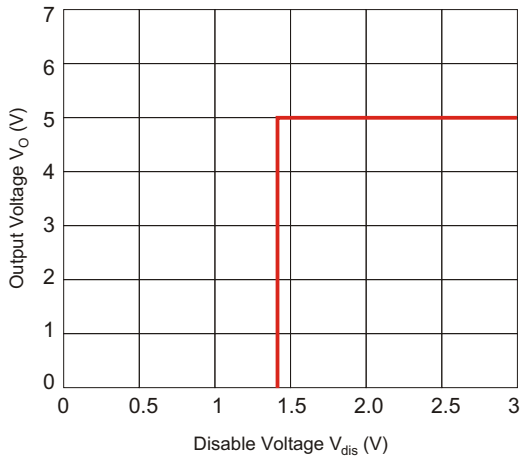

Figure 3. Output Voltage vs. Disable Voltage

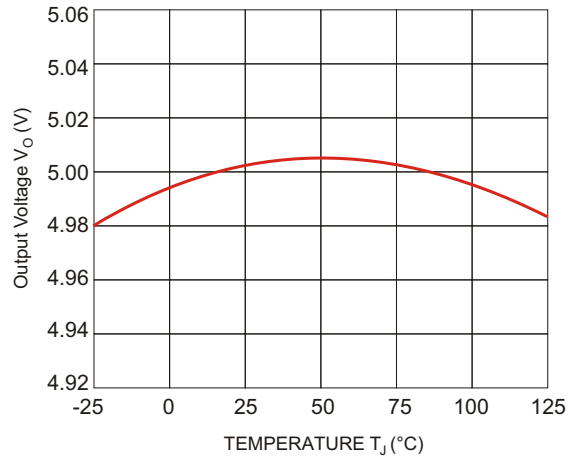

Figure 4. Output Voltage vs. Input Voltage

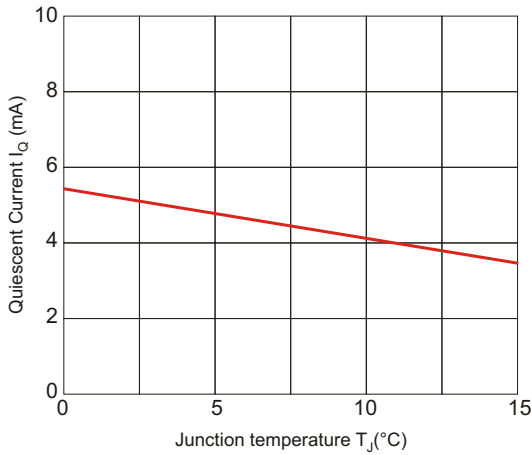

Figure 5. Quiescent Current vs. Temperature(T_J)

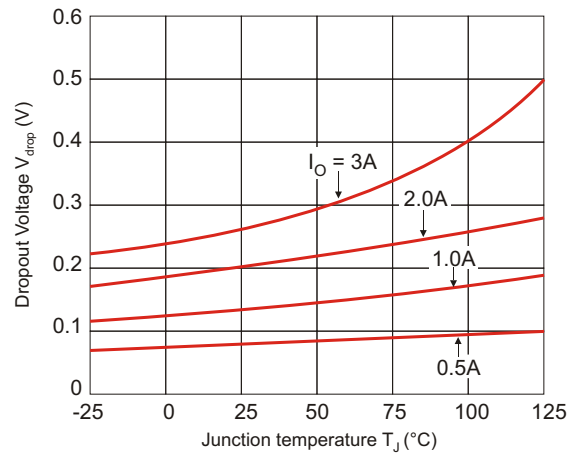

Figure 6. Quiescent Current vs. Temperature(T_J)

◆ TYPICAL PERFORMANCE CHARACTERISTICS

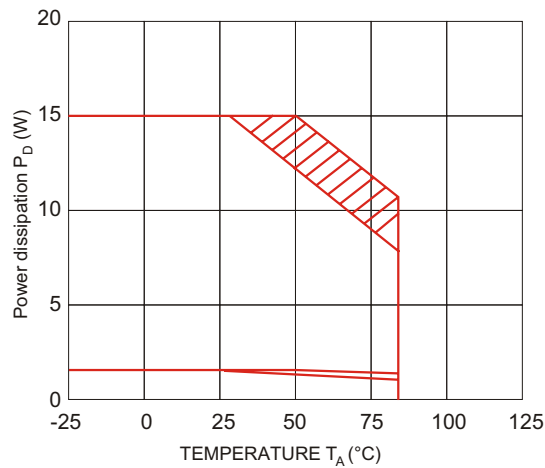

Figure 7. Quiescent Current vs. Temperature(T_J)

◆ TO-220F-4L PFABPACK PACKAGE OUTLINE DIMENSIONS

