

---

# **GMS81508A**

# **GMS81516A**

## **USER'S MANUAL**

### **Revision History**

#### **Rev 2.2 (Dec. 1998)**

Add the package dimension for 64LQFP on page 3-1, 4-1.

#### **Rev 2.1 (Nov. 1998)**

Operating Temperature, -10~75°C is extended to -20~85°C.

Add the unused port guidance on page 55.

Correct errata for opcode of "EOR [dp+X], EOR [dp]+Y, EOR {X}" in "Instruction Set".

Add the OTP device programming guidance, recommend using "Intelligent Mode".

Add the chapter for OTP programming manual as an appendix.

#### **Rev 2.0 (Sep. 1997)**

---

---

- CONTENTS -

<b>1. OVERVIEW</b> .....	<b>1</b>
1.1. FEATURES .....	1
1.2. BLOCK DIAGRAM.....	2
1.3. PIN ASSIGNMENT .....	3
1.4. PACKAGE DIMENSION .....	4
1.5. PIN DESCRIPTION.....	5
<b>2. FUNCTIONS</b> .....	<b>7</b>
2.1. REGISTERS .....	7
2.1.1. A - Register.....	8
2.1.2. X- Register.....	8
2.1.3. Y- Register .....	8
2.1.4. Stack Pointer .....	8
2.1.5. Program Counter.....	10
2.1.6. Program Status Word.....	10
2.2. MEMORY SPACE.....	12
2.2.1. RAM area .....	12
2.2.2. Peripheral Register area .....	12
2.2.3. Program ROM area .....	12
2.2.4. Peripheral Register List .....	14
2.3. CLOCK GENERATION CIRCUIT .....	16
2.3.1. Oscillation Circuit .....	16
2.3.2. Prescaler .....	17
2.4. BASIC INTERVAL TIMER.....	18
2.4.1. Control of Basic Interval Timer.....	18
2.5. WATCH DOG TIMER.....	19
2.5.1. Control of Watch Dog Timer .....	19
2.5.2. The output of WDT signal.....	20
2.6. TIMER.....	21
2.6.1. Control of Timer .....	23
2.6.2. Interval Timer.....	24
2.6.3. Event Counter .....	24
2.6.4. Pulse Output .....	24
2.6.5. Input Capture.....	24
2.7. EXTERNAL INTERRUPT .....	26
2.8. A/D CONVERTER .....	27
2.8.1. Control of A/D Converter .....	27
2.9. SERIAL I/O .....	29
2.9.1. Data Transmission/Receiving Timing .....	31
2.9.2. The Serial I/O operation by Srdy pin .....	31
2.9.3. The method of Serial I/O .....	32
2.9.4. The Method to Test Correct Transmission with S/W.....	32
2.10. PWM .....	33
2.10.1. Controls of PWM .....	33
2.11. BUZZER DRIVER.....	35
2.11.1. Buzzer Driver Operation .....	36
2.12. INTERRUPTS.....	37
2.12.1. Interrupt Circuit Configuration and Kinds.....	37
2.12.2. Interrupt Control.....	38
2.12.3. Interrupt Priority .....	39

---

---

2.12.4. <i>Interrupt Sequence</i> .....	40
2.12.5. <i>Software Interrupt</i> .....	41
2.12.6. <i>Multiple Interrupt</i> .....	42
2.13. STANDBY FUNCTION .....	44
2.13.1. <i>STOP Mode</i> .....	45
2.13.2. <i>STOP Mode Release</i> .....	45
2.14. RESET FUNCTION .....	47
<b>3. I/O PORTS.....</b>	<b>48</b>
3.1. R0 PORT .....	48
3.2. R1 PORT .....	49
3.3. R2 PORT .....	50
3.4. R3 PORT .....	51
3.5. R4 PORT .....	52
3.6. R5 PORT .....	53
3.7. R6 PORT .....	54
3.8. TERMINAL TYPES .....	56
<b>4. ELECTRICAL CHARACTERISTICS.....</b>	<b>60</b>
4.1. ABSOLUTE MAXIMUM RATINGS.....	60
4.2. RECOMMENDED OPERATING CONDITIONS.....	60
4.3. A/D CONVERTER CHARACTERISTICS .....	60
4.4. DC CHARACTERISTICS .....	61
4.5. AC CHARACTERISTICS .....	62
4.5.1. <i>Input Conditions</i> .....	62
4.5.2. <i>Serial Transfer</i> .....	63
4.5.3. <i>Microprocessor Mode I/O Timing</i> .....	64
4.5.4. <i>Bus Holding Timing</i> .....	65
<b>5. INSTRUCTION SET .....</b>	<b>66</b>

---

## 1. OVERVIEW

GMS81508/16 is a single chip microcomputer designed CMOS technology. The use of CMOS process enables extremely low power consumption.

This device using the G8MC Core includes several peripheral functions such as Timer, A/D Converter, Programmable Buzzer Driver, Serial I/O, Pulse Width Modulation Function, etc. ROM, RAM, I/O are placed on the same memory map in addition to simple instruction set.

### 1.1. FEATURES

	<b>GMS81508</b>	<b>GMS81516</b>
<b>ROM(Bytes)</b>	8K	16K
<b>RAM(Bytes)</b>	448 bytes(includes stack area)	
<b>Execution Time</b>	0.5us (@Xin=8MHz)	
<b>Basic Interval Timer</b>	8bit X 1ch.	
<b>Watch Dog Timer</b>	6bit X 1ch.	
<b>Timer</b>	8bitX 4ch.(or 16bit X 2ch.)	
<b>ADC</b>	8bit X 8ch.	
<b>PWM</b>	8bit X 2ch.	
<b>Serial I/O</b>	8bit X 1ch.	
<b>External Interrupt</b>	4ch.	
<b>Buzzer Driver</b>	Programmable Buzzer Driving Port	
<b>I/O Port</b>	4 - Input only 52 - Input/Output	
<b>Power Save Mode</b>	STOP Mode	
<b>Operating Voltage</b>	4.5 ~ 5.5V ( @ Xin=8MHz )	
<b>Operating Frequency</b>	1 ~ 8MHz	
<b>Package</b>	64SDIP, 64QFP	
<b>OTP</b>	GMS81516T	
<b>Application</b>	Home Appliances, LED Applications	

1.2. BLOCK DIAGRAM

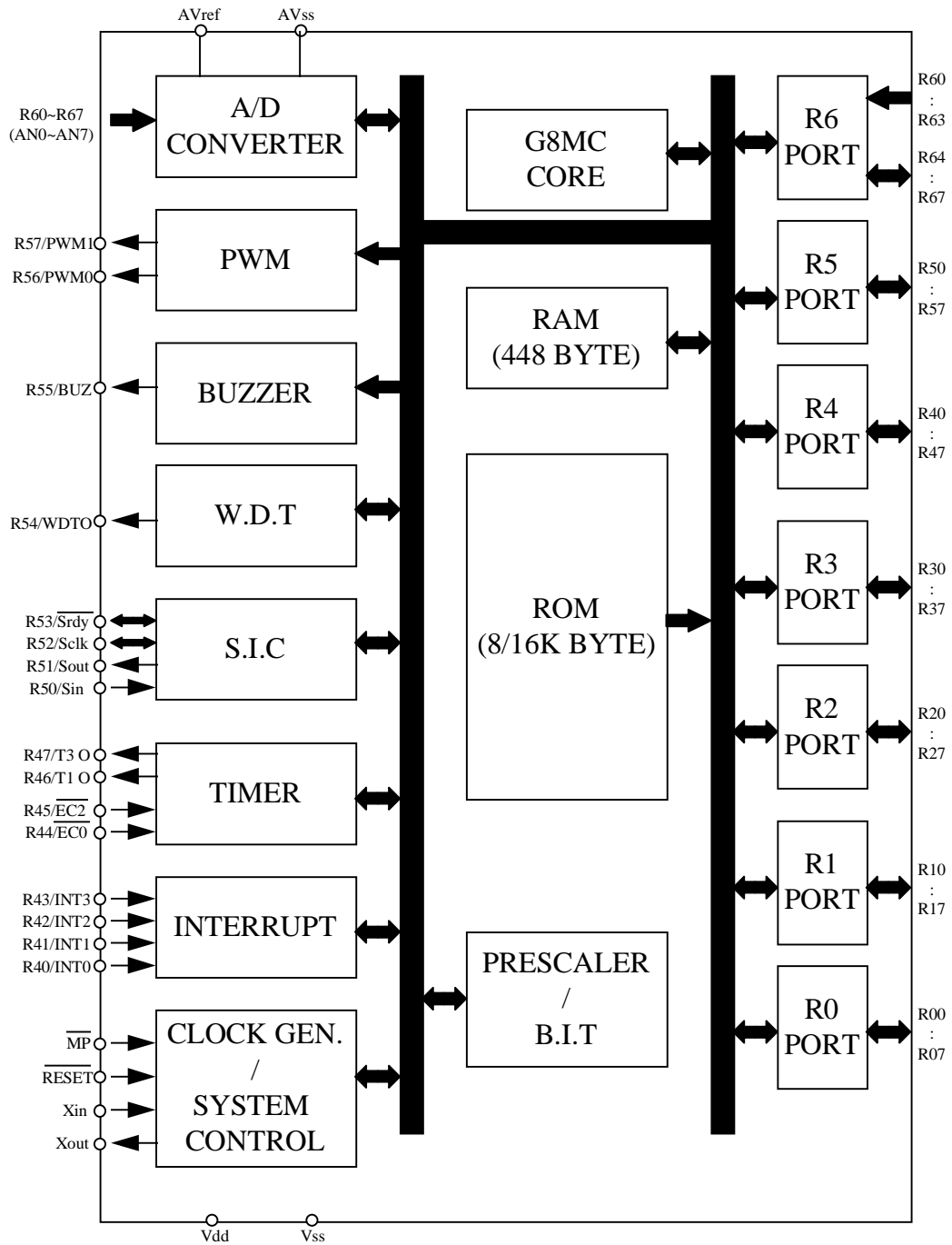

1.3. PIN ASSIGNMENT

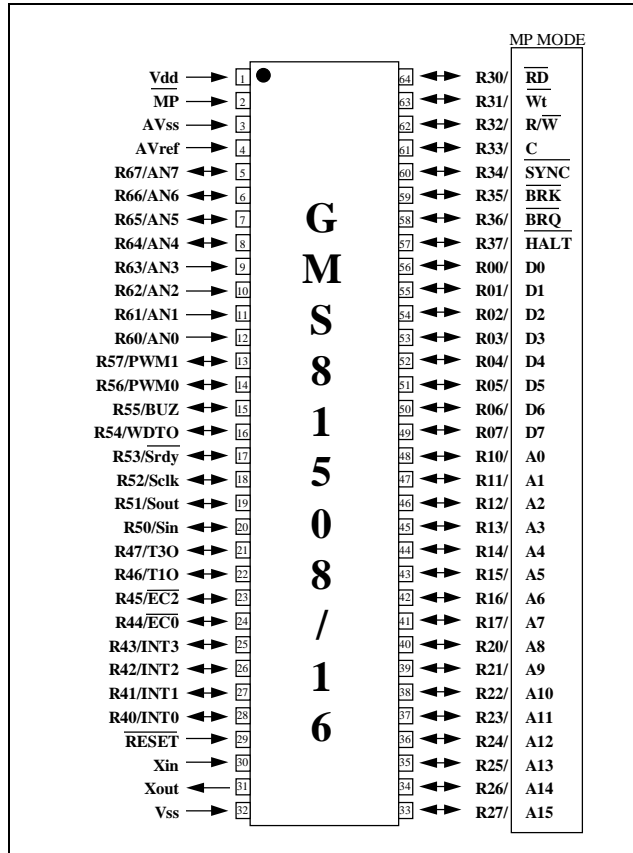

64 SDIP

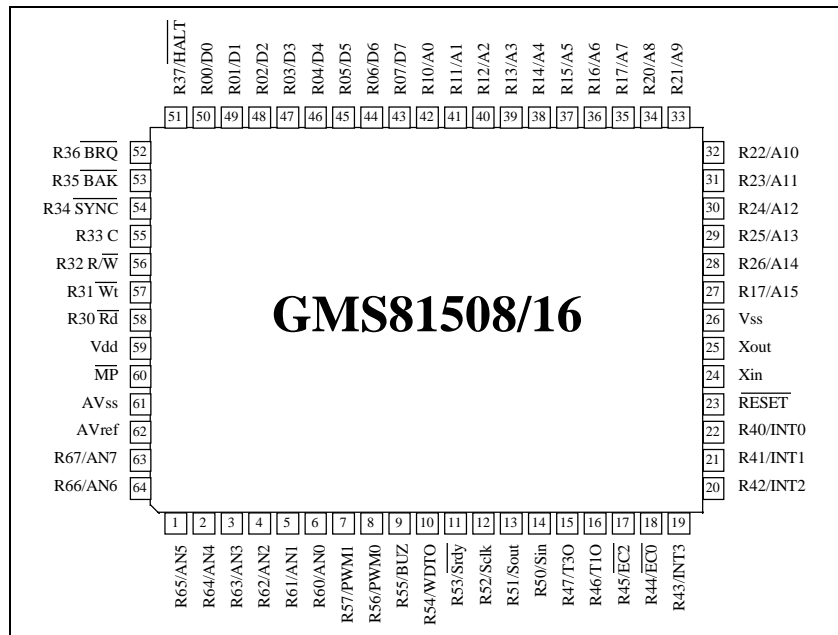

64 QFP

64LQFP

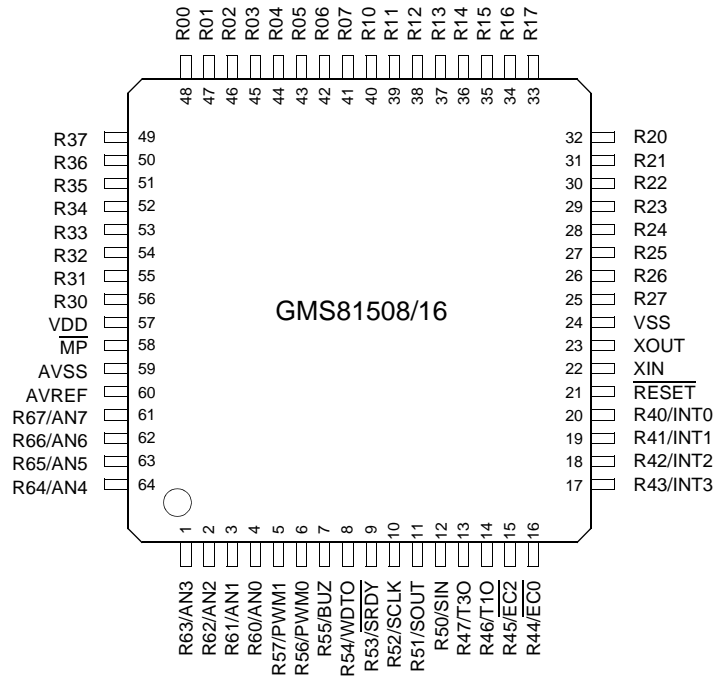

1.4 PACKAGE DIMENSION

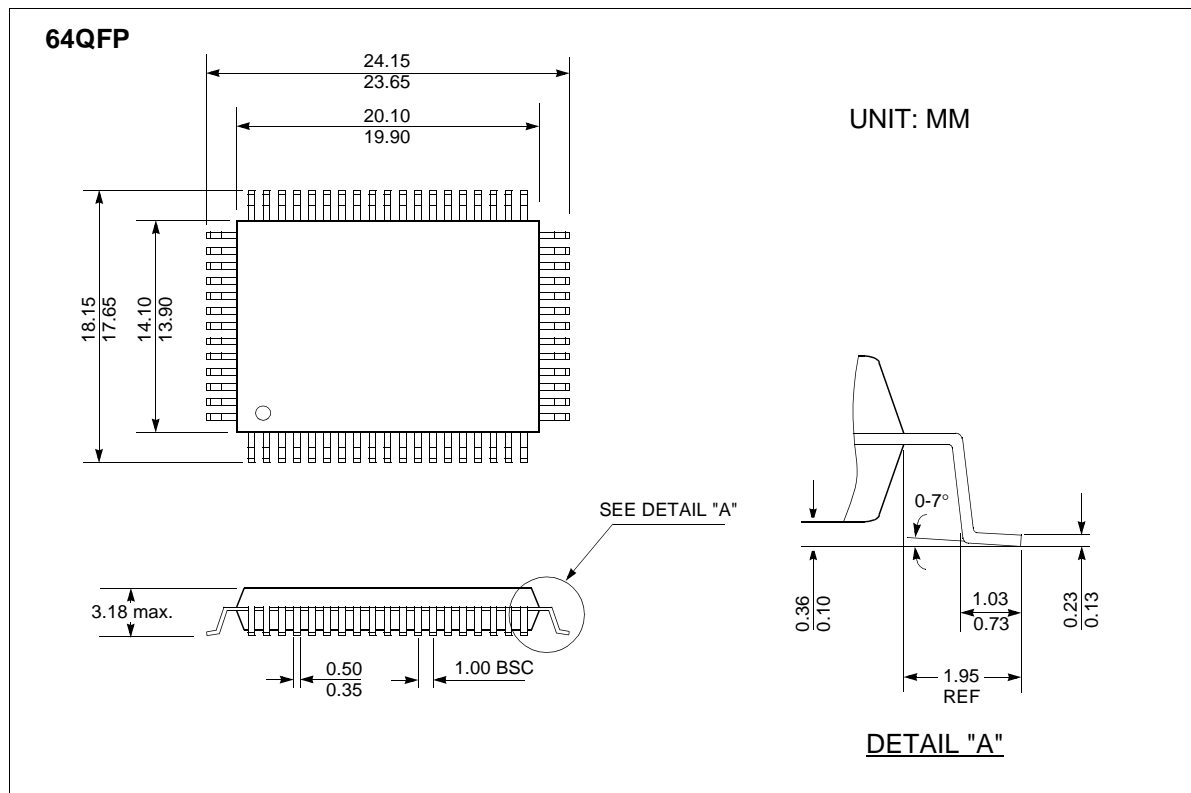
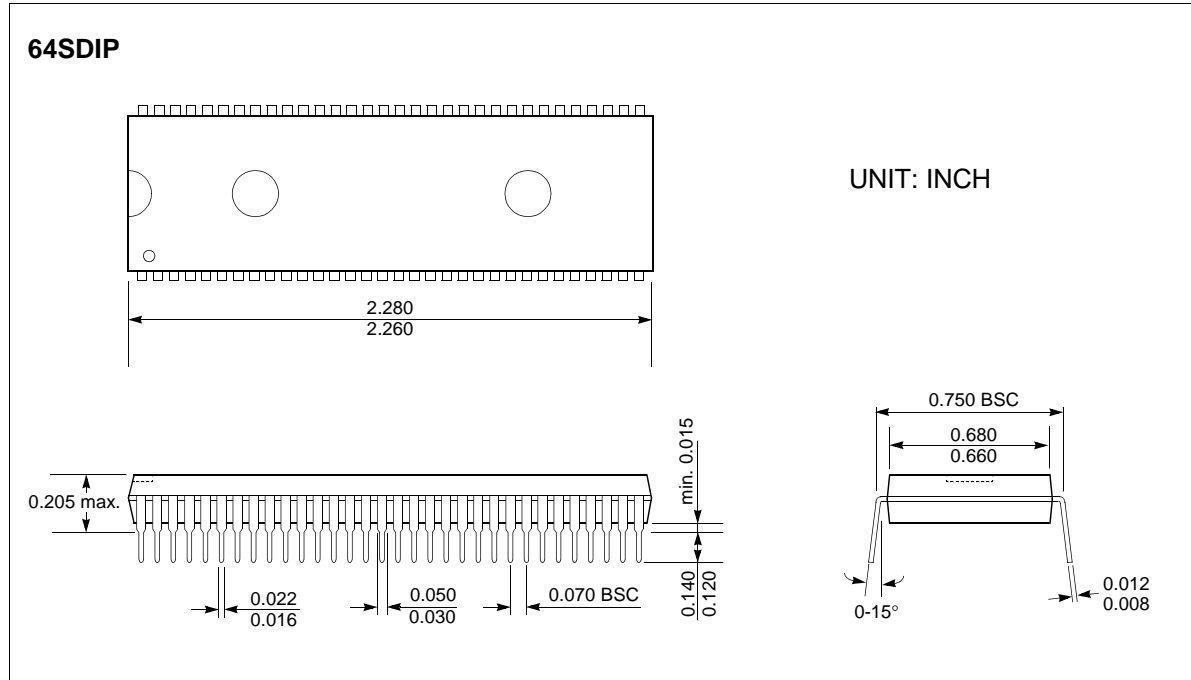



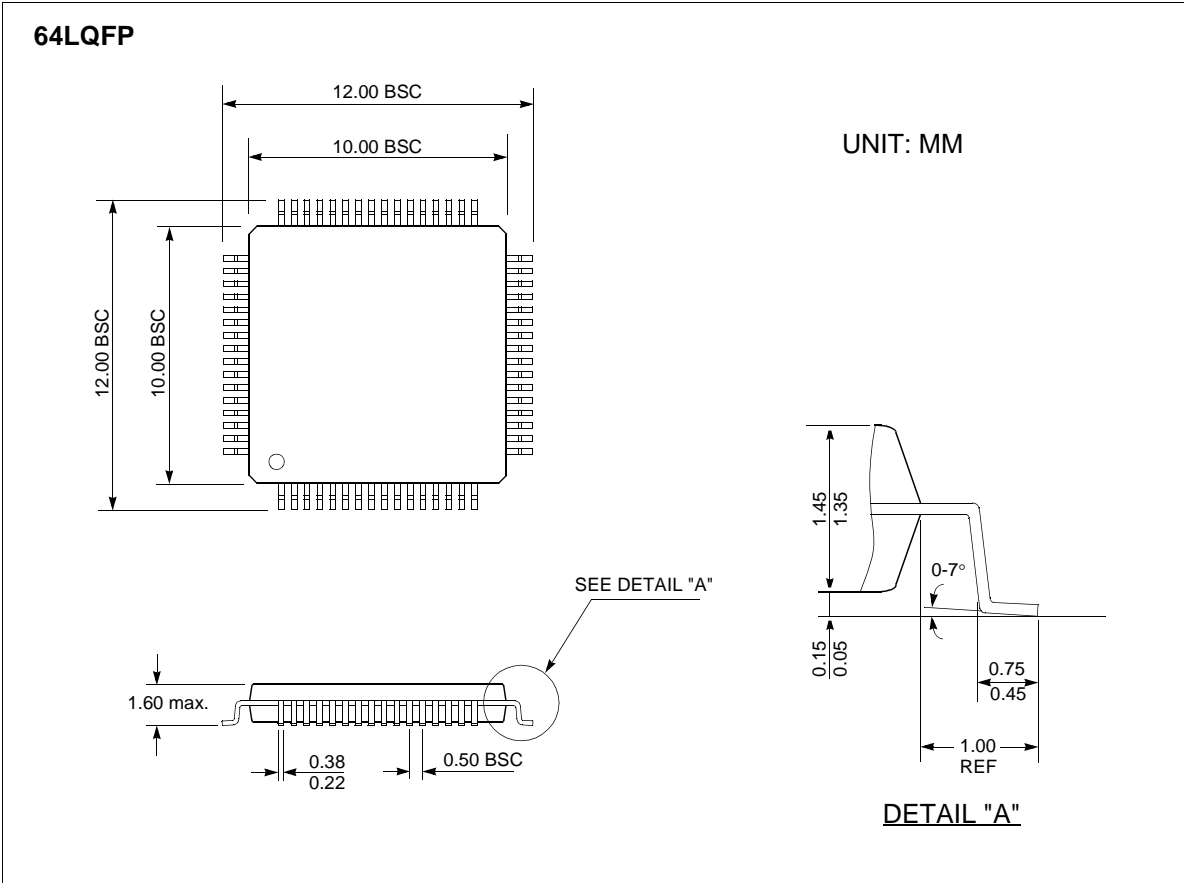

## 1.5. PIN DESCRIPTION

Classification	No.	Symbol	I/O	Descriptions
Power	1	Vdd	I	Power Supply Input Pin(4.5~5.5V)
	32	Vss	I	Ground(0V)
System Control or Clock	2	$\overline{MP}$	I	Controls Microprocess Mode of the Chip At "H" input : Single Chip Mode At "L" input : Microprocess Mode
	29	$\overline{RESET}$	I	In the state of "L" level, system enter to the reset state.
	30	Xin	I	This chip has an internal clock generating circuit. To control generating frequency, an external ceramic or a quartz crystal oscillator is connected between Xin and Xout pins.
	31	Xout	I	If external clock is used, the clock source should be connected to the Xin pin and the Xout pin should be left open.
Timer	24	$\overline{EC0}$	I	Event Counter Source Clock Input Pin
	23	$\overline{EC2}$	I	
	22	T1O	O	Timer Counter Overflow Output Pin
	21	T3O	O	
Ext. Interrupt	28	INT0	I	External Interrupt Request Signal Input Pin
	27	INT1	I	
	26	INT2	I	
	25	INT3	I	
A/D Converter	4	AVref	I	Reference Voltage Input Pin for A/D Converter
	3	AVss	I	Ground Level Input Pin for A/D Converter
	12	AN0	I	Analog Voltage Input Pin for A/D Converter
	11	AN1	I	
	10	AN2	I	
	9	AN3	I	
	8	AN4	I	
	7	AN5	I	
	6	AN6	I	
5	AN7	I		
Serial I/O	17	$\overline{Srdy}$	I/O	Receive Enable Output Pin
	18	Sclk	I/O	Serial Clock Output Pin
	19	Sout	O	Serial Data Output Pin
	20	Sin	I	Serial Data Input Pin
P.W.M	14	PWM0	O	PWM Pulse Output Pin
	13	PWM1	O	
Buzzer	15	BUZ	O	Buzzer Driving Frequency Output Pin
W.D.T	16	WDTO	O	Watch dog Timer Overflow Output Pin

Classification	No.	Symbol	I/O	Description
I/O Port	49 : 56	R00 : R07	I/O	R0 Port ( Can be determined I/O by R0DD ) In MP mode, This port functions as 8-bit data bus for the CPU. (D0~D7)
	41 : 48	R10 : R17	I/O	R1 Port ( Can be determined I/O by R1DD ) In MP mode, This functions as 8-bit lower address output pins. (A0~A7)
	33 : 40	R20 : R27	I/O	R2 Port ( Can be determined I/O by R2DD ) In MP mode, This functions as 8-bit higher address output pins.(A8~A15)
	57 : 64	R30 : R37	I/O	R3 Port ( Can be determined I/O by R3DD ) In MP mode, This port functions as 8-bit control bus for the CPU.
	28 : 21	R40 : R47	I/O	R4 Port ( Can be determined I/O by R4DD )
	20 : 13	R50 : R57	I/O	R5 Port ( Can be determined I/O by R5DD )
	12 : 9	R60 : R63	I	R6 Port Input Only
	8 : 5	R64 : R65	I/O	R6 Port ( Can be determined I/O by R6DD )

## 2. FUNCTIONS

### 2.1. REGISTERS

6 registers are built-in the CPU of G8MC. Accumulator(A), Index register X, Y, Stack Pointer (SP) and Program Status Word(PSW) consists of 8-bit registers. Program Counter(PC) consists of 16-bit registers. The contents of these registers are undefined after RESET.

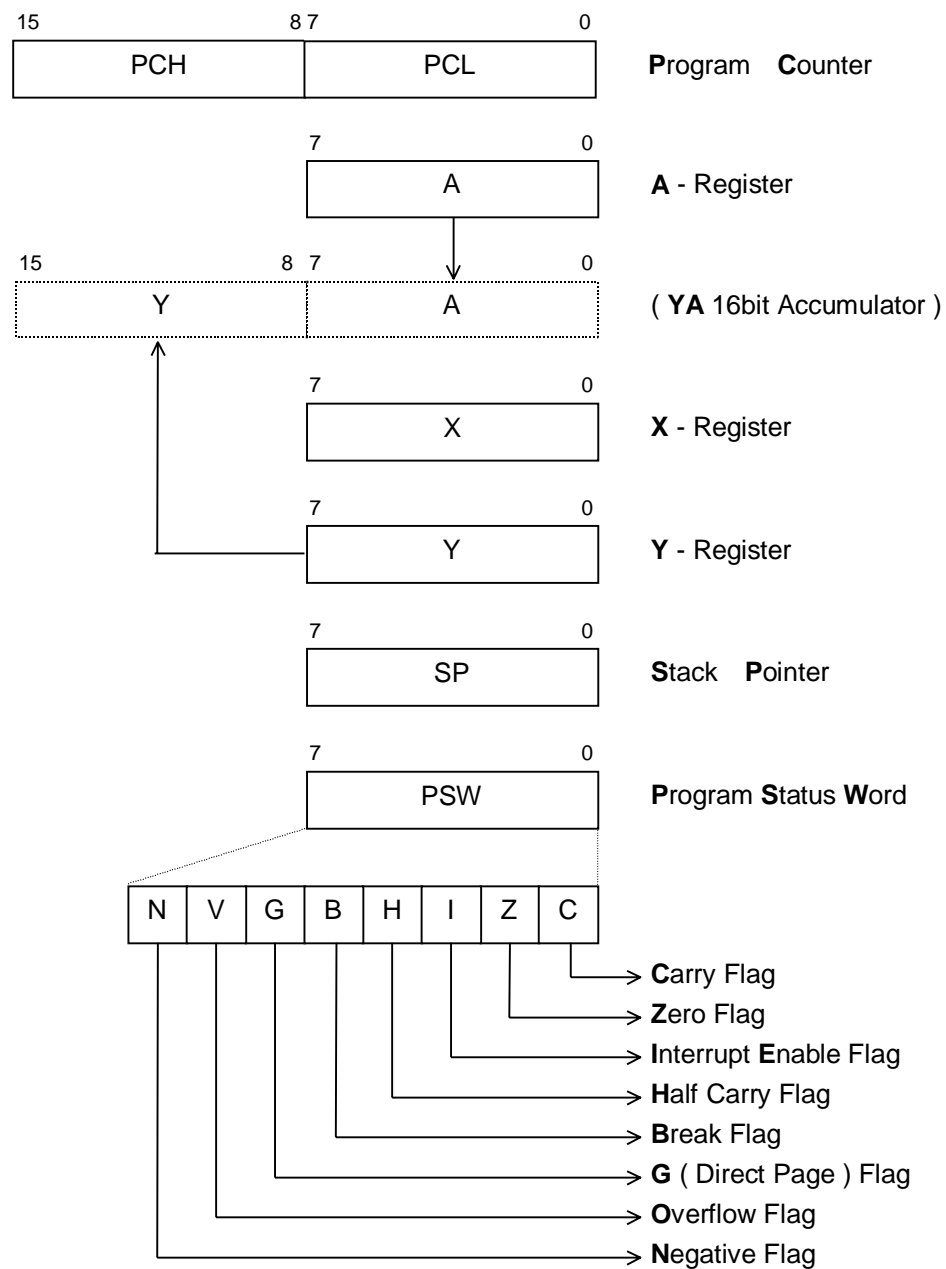

### 2.1.1. A - Register

The accumulator is the 8-bit general purpose register. This is used register for data operation, data transfer, temporary saves and conditional judgment.

Accumulator can be used as a 16-bit register with Y register and has a lower 8-bit data.

In case of multiplication instruction(MUL), it works as a multiplier. After execution of MUL instruction, Accumulator has lower 8-bit data of the results(16-bit).

In case of division instruction(DIV), it has the lower 8-bit of dividend (16-bit)

### 2.1.2. X- Register

In index addressing mode, this register is executed as a 8-bit index register within direct page(RAM area). also, In indirect addressing mode, it is destination address register.

This register can be used as a increment, decrement, comparison, and data transfer function.

In case of division instruction(DIV), it works as a divisor.

### 2.1.3. Y- Register

In index addressing mode, this register is executed as a index register.

In case of 16-bit operation instruction, this register has upper 8-bit of YA (16-bit accumulator).

In case of multiplication instruction(MUL), this register is executed as a multiplicand register. After multiplication operation, it has the upper 8-bit of the result.

In case of division instruction, it is executed as a dividend(upper 8-bit). After division operation, it has quotient.

This register can be used as a loop counter of conditional branch command. (e.g. DBNE Y, rel)

### 2.1.4. Stack Pointer

The stack pointer(SP) is an 8-bit register used during subroutine calling and interrupts.

When branching out from an on-going routine to subroutine or interrupt routine, it is necessary to remember the return address. normally, internal RAM is used for storing the return address and this area is called stack area. SP is pointer to show where the stack data are stored within the stack area.

The stack area is located in 1-Page of internal RAM. SP must be initialized by SW because the contents of SP is undefined after RESET.

```
ex)   LDX      #0FEH      ;0FEH -> X register
      TXSP      ;X -> SP
```

**caution) You can't use !01FFH as stack. If you use this area, mal-function would be occurred.**

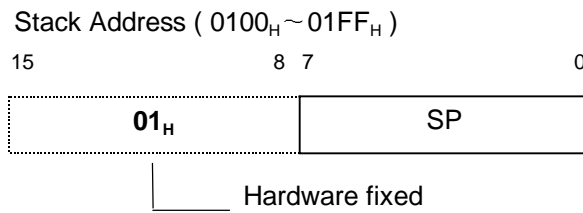

The belows shows data store and restore sequence to/from stack area.

① Interrupt

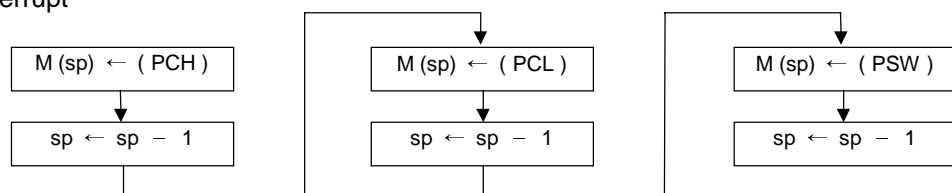

② RETI

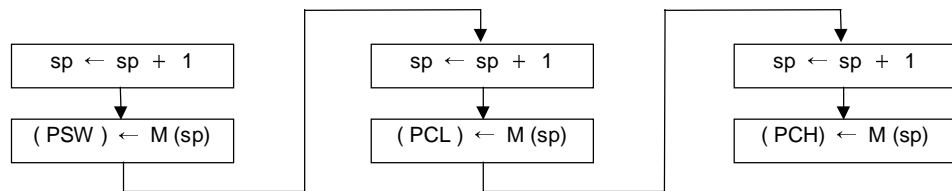

③ Subroutine CALL

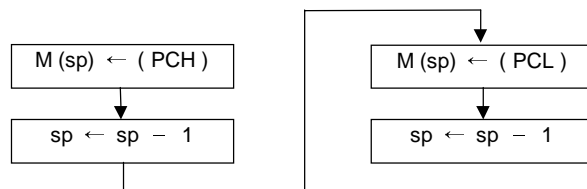

④ RET

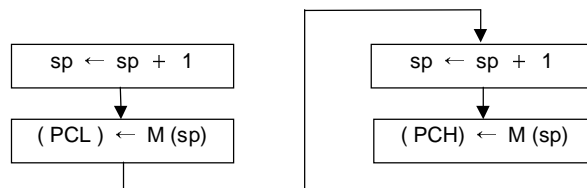

⑤ PUSH A ( X, Y, PSW )

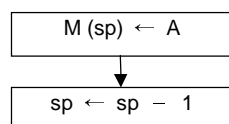

⑥ POP A ( X, Y, PSW )

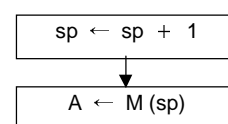

### 2.1.5. Program Counter

The program counter(PC) is a 16-bit counter which consists of 8-bit register PCH and PCL. The addressing space is 64K bytes.

This counter indicates the address of the next instruction to be executed.

In reset state, the program counter (PC) has reset routine address in address FFFFH and FFFE H .

### 2.1.6. Program Status Word

PSW is an 8-bit register which is composed of flags to maintain the condition of the processor immediately after an operation.

After RESET, The contents of PSW is set to "00H".

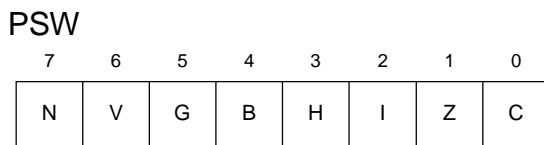

#### ① Carry Flag ( C )

After an operation, it is set to "1" when there is a carry from bit7 of ALU or not a borrow.

SETC,CLRC instructions allow direct access for setting and resetting.

it can be used as a 1-bit accumulator.

It is a branch condition flag of BCS, BCC instructions.

#### ② Zero Flag ( Z )

After an operation including 16-bit operation, it is set to "1" when the result is "0".

It is a branch condition flag of BEQ, BNE.

#### ③ Interrupt Enable Flag ( I )

This flag is used to enable/disable all interrupts except interrupt caused by BRK instruction.

When this flag is "1", it means interrupt enable condition. When an interrupt is accept, this flag is automatically set to "0" thereby preventing other interrupts. also it is set to "1" by RETI instruction.

This flag is set and cleared by EI, DI instructions.

#### ④ Half Carry Flag ( H )

After an operation, it is set when there is a carry from bit3 of ALU or is not a borrow from bit4 of ALU.

It can not be set by any instruction. it is cleared by CLR V instruction like V flag.

⑤ Break Flag ( **B** )

This flag is set by BRK (S/W interrupt) instruction to distinguish BRK and TCALL instruction having the same vector address.

⑥ Direct Page Flag ( **G** )

This flag assign direct page (0-page, 1-page) for direct addressing mode. When G-flag is "0", the direct addressing space is in 0-page(0000H~00FFH). When G-flag is "1", the direct addressing space is in 1-page(0100H~01FFH).

It is set and cleared by SETG, CLRG instruction

⑦ Overflow Flag ( **V** )

This flag functions when one word is added or subtracted in binary with the sign. When results exceeds +127 or -128, this flag is set.

When BIT instruction is executed, The bit6 of memory is input into V-flag.

This flag is cleared by CLRV instruction, but set instruction is not exist.

It is a branch condition flag of BVS, BVC.

⑧ Negative Flag ( **N** )

N-flag is set when the result of a data transfer or operation is negative (bit7 is "1").

it means the bit-7 of memory is sign bit. thereby data is valid in the range of -128 ~ +127.

When BIT instruction is executed, The bit7 of memory is input into N-flag.

Set or clear instruction is not exist.

It is a branch condition flag of BPL, BMI instruction.



## **2.2. MEMORY SPACE**

All RAM ,ROM,I/O, Peripheral Register are placed in the same memory area. Therefore, same instructions enable both data transfer and operation without the need to distinguish memory and I/O. The program counter of GMS81508/16 consists of 16-bit and memory addressing space is 64K byte.

### **2.2.1. RAM area**

RAM(includes stack area) is 448 Bytes ( 0000<sub>H</sub>~01FF<sub>H</sub> ).

The internal RAM is used for data storage, subroutine calling or stack area when interrupts occur. When RAM is used as the stack area, the depth of the subroutine "nesting" and the interrupt levels should be kept in mind in order to avoid destruction of the RAM contents.

### **2.2.2. Peripheral Register area**

Address 00C0<sub>H</sub>~00FF<sub>H</sub> are assigned for peripheral register.

### **2.2.3. Program ROM area**

- ① PCALL subroutines must be located in **PCALL** area ( FF00<sub>H</sub>~FFBF<sub>H</sub> ).
- ② **TCALL** vector area ( FFC0<sub>H</sub>~FFDF<sub>H</sub> ) has the vector address corresponding to TCALL instruction.
- ③ **Interrupt Vector** area ( FFE0<sub>H</sub>~FFFF<sub>H</sub> ) has the vector address of interrupts, inclusive RESET.

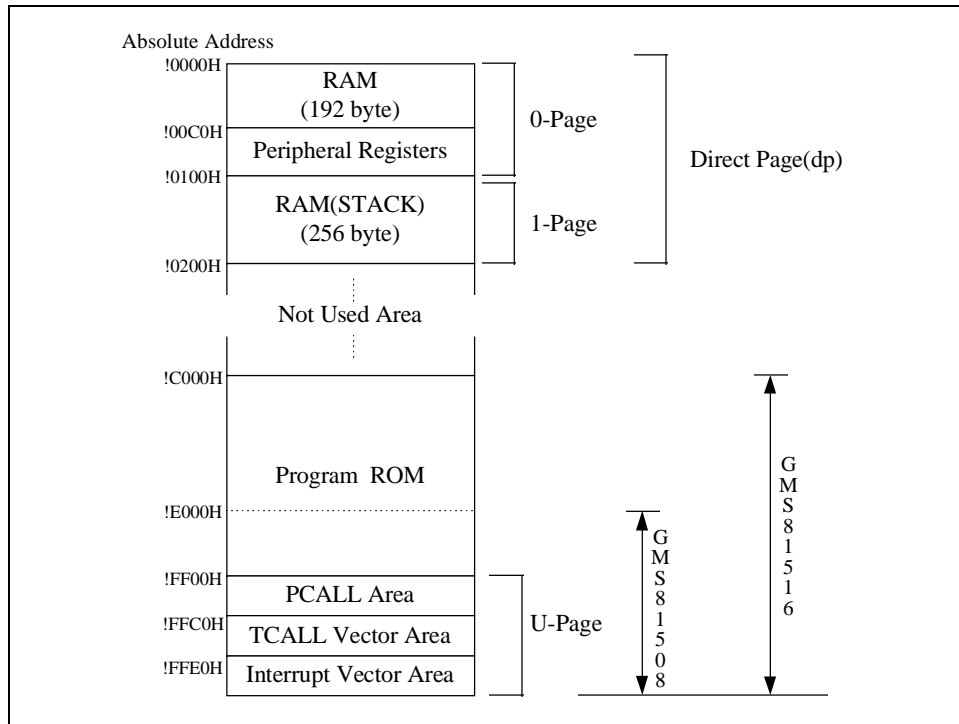

■ VECTOR TABLE

TCALL		INTERRUPT	
Address	Vector	Address	Vector
FFC0H - FFC1H	TCALL 15	FFE0H - FFE1H	not used
FFC2H - FFC3H	TCALL 14	FFE2H - FFE3H	not used
FFC4H - FFC5H	TCALL 13	FFE4H - FFE5H	Serial I/O
FFC6H - FFC7H	TCALL 12	FFE6H - FFE7H	Basic Interval Timer
FFC8H - FFC9H	TCALL 11	FFE8H - FFE9H	Watch Dog Timer
FFCAH - FFCBH	TCALL 10	FFEAH - FFEBH	A/D Converter
FFCCH - FFCDH	TCALL 9	FFECH - FFEDH	Timer 3
FFCEH - FFCFH	TCALL 8	FFEEH - FFEFH	Timer 2
FFD0H - FFD1H	TCALL 7	FFF0H - FFF1H	Timer 1
FFD2H - FFD3H	TCALL 6	FFF2H - FFF3H	Timer 0
FFD4H - FFD5H	TCALL 5	FFF4H - FFF5H	Ext. Int. 3
FFD6H - FFD7H	TCALL 4	FFF6H - FFF7H	Ext. Int. 2
FFD8H - FFD9H	TCALL 3	FFF8H - FFF9H	Ext. Int. 1
FFDAH - FFDBH	TCALL 2	FFFAH - FFFBH	Ext. Int. 0
FFDCH - FFDDH	TCALL 1	FFFCH - FFFDH	not used
FFDEH - FFDFH	TCALL 0	FFFEH - FFFFH	RESET

2.2.4. Peripheral Register List

Address	Register Name	SYMBOL	R/W	RESET VALUE								
				7	6	5	4	3	2	1	0	
00C0 <sub>H</sub>	R0 PORT DATA REGISTER	<b>R0</b>	R/W	Undefined								
00C1 <sub>H</sub>	R0 PORT I/O DIRECTION REGISTER	<b>R0DD</b>	W	0	0	0	0	0	0	0	0	0
00C2 <sub>H</sub>	R1 PORT DATA REGISTER	<b>R0</b>	R/W	Undefined								
00C3 <sub>H</sub>	R1 PORT I/O DIRECTION REGISTER	<b>R0DD</b>	W	0	0	0	0	0	0	0	0	0
00C4 <sub>H</sub>	R2 PORT DATA REGISTER	<b>R0</b>	R/W	Undefined								
00C5 <sub>H</sub>	R2 PORT I/O DIRECTION REGISTER	<b>R0DD</b>	W	0	0	0	0	0	0	0	0	0
00C6 <sub>H</sub>	R3 PORT DATA REGISTER	<b>R0</b>	R/W	Undefined								
00C7 <sub>H</sub>	R3 PORT I/O DIRECTION REGISTER	<b>R0DD</b>	W	0	0	0	0	0	0	0	0	0
00C8 <sub>H</sub>	R4 PORT DATA REGISTER	<b>R4</b>	R/W	Undefined								
00C9 <sub>H</sub>	R4 PORT I/O DIRECTION REGISTER	<b>R4DD</b>	W	0	0	0	0	0	0	0	0	0
00CA <sub>H</sub>	R5 PORT DATA REGISTER	<b>R5</b>	R/W	Undefined								
00CB <sub>H</sub>	R5 PORT I/O DIRECTION REGISTER	<b>R5DD</b>	W	0	0	0	0	0	0	0	0	0
00CC <sub>H</sub>	R6 PORT DATA REGISTER	<b>R6</b>	R/W	Undefined								
00CD <sub>H</sub>	R6 PORT I/O DIRECTION REGISTER	<b>R6DD</b>	W	0	0	0	0	-	-	-	-	-
00D0 <sub>H</sub>	PORT R4 MODE REGISTER	<b>PMR4</b>	W	0	0	0	0	0	0	0	0	0
00D1 <sub>H</sub>	PORT R5 MODE REGISTER	<b>PMR5</b>	W	-	-	0	0	-	-	-	-	-
00D2 <sub>H</sub>	TEST MODE REGISTER	<b>TMR</b>	W	-	-	-	-	-	0	0	0	0
00D3 <sub>H</sub>	BASIC INTERVAL REGISTER	<b>BITR</b>	R	Undefined								
	CLOCK CONTROL REGISTER	<b>CKCTLR</b>	W	-	-	0	1	0	1	1	1	1
00E0 <sub>H</sub>	WATCH DOG TIMER	<b>WDTR</b>	W	-	0	1	1	1	1	1	1	1
00E2 <sub>H</sub>	TIMER MODE REGISTER 0	<b>TM0</b>	R/W	0	0	0	0	0	0	0	0	0
00E3 <sub>H</sub>	TIMER MODE REGISTER 2	<b>TM2</b>	R/W	0	0	0	0	0	0	0	0	0
00E4 <sub>H</sub>	TIMER0 DATA REGISTER	<b>TDR0</b>	R/W	Undefined								
00E5 <sub>H</sub>	TIMER1 DATA REGISTER	<b>TDR1</b>	R/W	Undefined								
00E6 <sub>H</sub>	TIMER2 DATA REGISTER	<b>TDR2</b>	R/W	Undefined								
00E7 <sub>H</sub>	TIMER3 DATA REGISTER	<b>TDR3</b>	R/W	Undefined								
00E8 <sub>H</sub>	A/D CONVERTER MODE REGISTER	<b>ADCM</b>	R/W	-	-	0	0	0	0	0	0	1
00E9 <sub>H</sub>	A/D CONVERTER DATA REGISTER	<b>ADR</b>	R	Undefined								
00EA <sub>H</sub>	SERIAL I/O MODE REGISTER	<b>SIOM</b>	R/W	-	0	0	0	0	0	0	0	1

Address	Register Name	SYMBOL	R/W	RESET VALUE								
				7	6	5	4	3	2	1	0	
00EB <sub>H</sub>	SERIAL I/O REGISTER	<b>SIOR</b>	R/W	Undefined								
00EC <sub>H</sub>	BUZZER DRIVER REGISTER	<b>BUR</b>	W	Undefined								
00F0 <sub>H</sub>	PWM0 DATA REGISTER	<b>PWMR0</b>	W	Undefined								
00F1 <sub>H</sub>	PWM1 DATA REGISTER	<b>PWMR1</b>	W	Undefined								
00F2 <sub>H</sub>	PWM CONTROL REGISTER	<b>PWMCR</b>	W	00								
00F3 <sub>H</sub>	INTERRUPT MODE REGISTER	<b>IMOD</b>	R/W	-	-	0	0	0	0	0	0	0
00F4 <sub>H</sub>	INTERRUPT ENABLE REGISTER LOW	<b>IENL</b>	R/W	0	0	0	0	-	-	-	-	-
00F5 <sub>H</sub>	INTERRUPT REQUEST FLAG REGISTER LOW	<b>IRQL</b>	R/W	0	0	0	0	-	-	-	-	-
00F6 <sub>H</sub>	INTERRUPT ENABLE REGISTER HIGH	<b>IENH</b>	R/W	0	0	0	0	0	0	0	0	0
00F7 <sub>H</sub>	INTERRUPT REQUEST FLAG REGISTER HIGH	<b>IRQH</b>	R/W	0	0	0	0	0	0	0	0	0
00F8 <sub>H</sub>	EXT. INTERRUPT EDGE SELECTION REGISTER	<b>IEDS</b>	W	0	0	0	0	0	0	0	0	0

※ -: Not Used

※ Write Only Register **can not be accessed** by bit manipulation instruction.

### 2.3. CLOCK GENERATION CIRCUIT

The clock generation circuit of GMS81508/16 consists of oscillation circuit, prescaler, Basic Interval Timer.

The source clock of peripherals is provided by 11-bit prescaler.

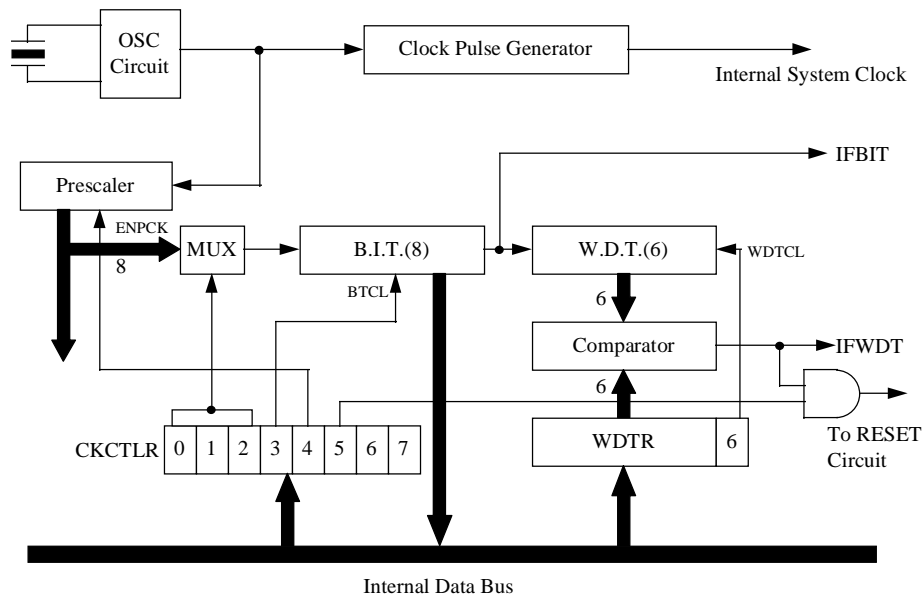

#### 2.3.1. Oscillation Circuit

The clock signal incoming from crystal oscillator or ceramic resonator via Xin and Xout or from external clock via Xin is supplied to Clock Pulse Generator and Prescaler.

The internal system clock for CPU is made by Clock Pulse Generator, and several peripheral clock is divided by prescaler.

The clock generation circuit of crystal oscillator or ceramic resonator is shown in below.

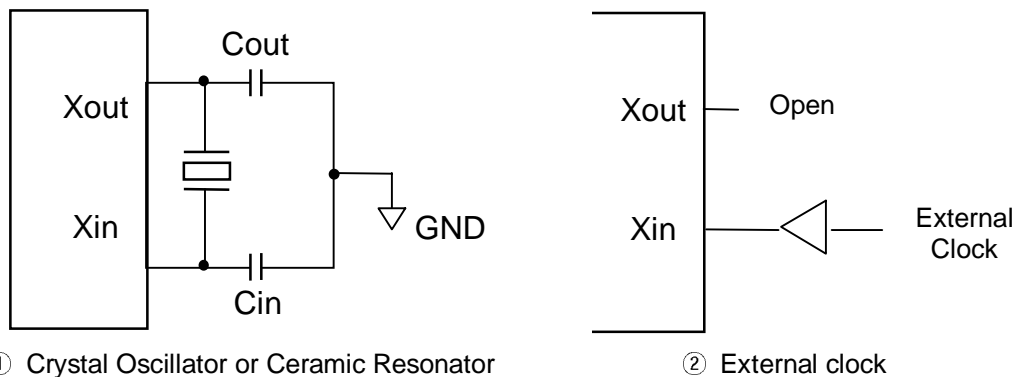

★ In **STOP** Mode, The oscillation is stopped, Xin pin goes to "L" level status, and Xout pin goes to "H" level state.

### 2.3.2. Prescaler

The prescaler consists of 11-bit binary counter, and input clock is supplied by oscillation circuit. The frequency divided by prescaler is used as a source clock for peripherals.

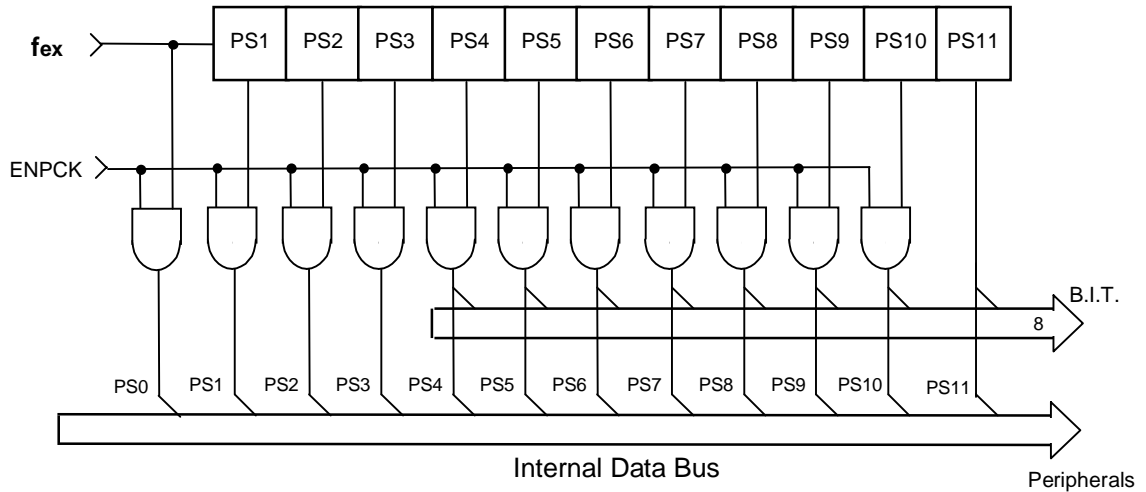

◆ Frequency-Divided Outputs of Prescaler

$f_{ex}$ (MHz)	PS1	PS2	PS3	PS4	PS5	PS6	PS7	PS8	PS9	PS10	PS11	
8	Interval	4 MHz	2 MHz	1 MHz	500 kHz	250 kHz	125 kHz	62.5 kHz	31.25 kHz	15.36 kHz	7.18 kHz	3.59 kHz
	Period	250 ns	500 ns	1 $\mu$ s	2 $\mu$ s	4 $\mu$ s	8 $\mu$ s	16 $\mu$ s	32 $\mu$ s	64 $\mu$ s	128 $\mu$ s	256 $\mu$ s

The peripheral clock supplied from prescaler can be stopped by ENPCK. (However, PS11 cannot be stopped by ENPCK)

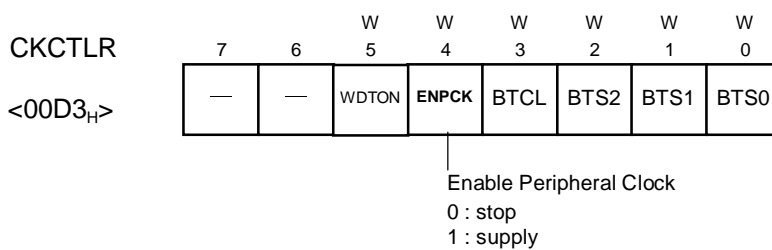

## 2.4. BASIC INTERVAL TIMER

The Basic Interval Timer(B.I.T.) has 8-bit binary counter. The operations is shown below.

- . Generates reference time interval interrupt request as a timer.
- . The counting value of B.I.T. can be read.  
( Note; The writing at same address overwrites the CKCTLR.)
- . The overflow of B.I.T be used the source clock of Watch Dog Timer.

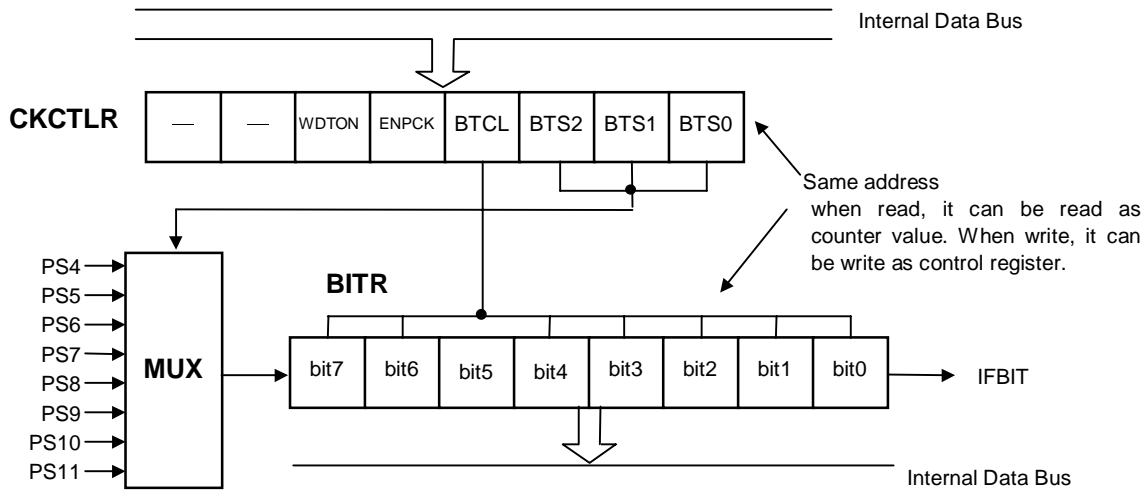

### 2.4.1. Control of Basic Interval Timer

The Basic Interval Timer is free running timer. When the counting value is changed "0FFH" to "00H" , The interrupt request flag is generated. The counter can be cleared by setting **BTCL** (Bit 3 of CKCTLR) and the BTCL is auto-cleared after 1 machine cycle. The initial state (after Reset) of BTCL is "0".

The input clock of Basic Interval Timer is selected by BTS2~BTS0 (Bit2~0 of CKCTLR) among the prescaler outputs (PS4~PS11).

The Basic Interval Timer Register (BITR) can be read.

The CKCTLR and the BITR have a same address (00D3H). So, If you write to this address, the CKCTLR would be controlled. If you read this address, the counting value of BITR would be read.

#### ■ CLOCK CONTROL REGISTER

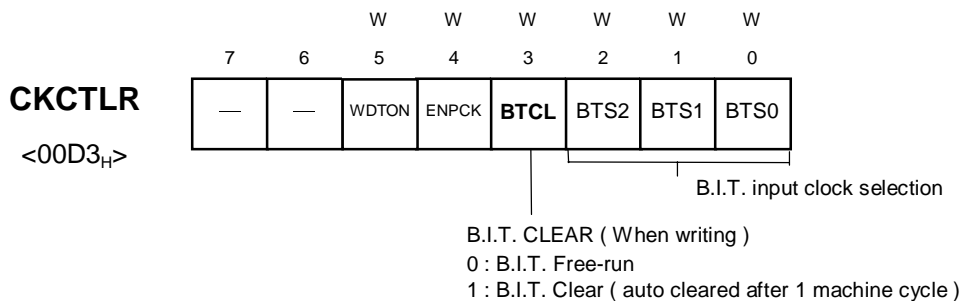

## ■ BASIC INTERVAL TIMER DATA REGISTER



## 2.5. WATCH DOG TIMER

The Watch Dog Timer is a means of recovery from a system problem.

In this Device, the Watch Dog Timer consists of 6-bit binary counter, 6-bit comparator and watch dog timer register(WDTR). The source clock of WDT is overflow of Basic Interval Timer. The interrupt request of WDT is generated when the counting value of WDT equal to the contents of WDTR( bit0~5). This can be used as s/w interrupt or MICOM RESET signal(Watch Dog Function).

### 2.5.1. Control of Watch Dog Timer

It can be used as 6-bit timer or WDT according to bit5(WDTON) of Clock Control Register (CKCTLR). The counter can be cleared by setting **WDTCL** ( Bit 6 of WDTR) and the WDTCL is auto-cleared after 1 machine cycle. The initial state (after Reset) of WDTCL is "0".

## ■ CLOCK CONTROL REGISTER

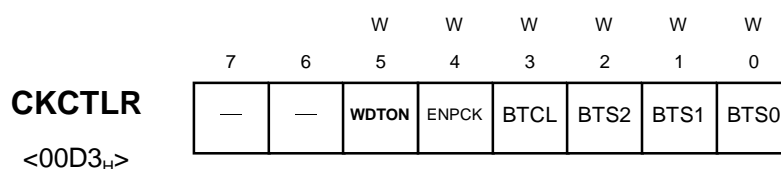

WDT ON  
0 : 6-bit Timer  
1 : Watch Dog Timer

## ■ WATCH DOG TIMER REGISTER

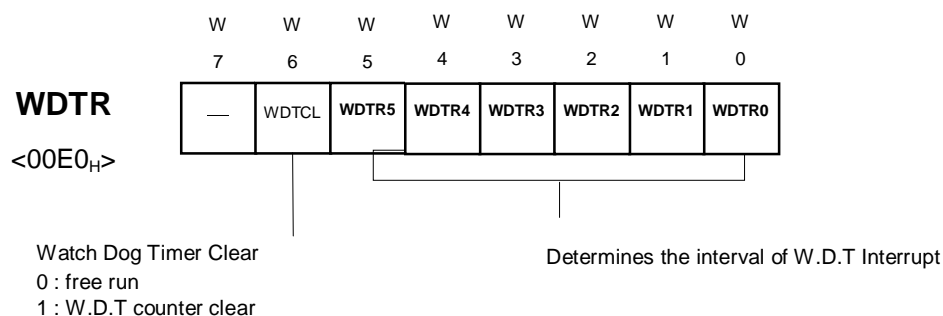



## HYUNDAI MicroElectronics

The interval of WDT interrupt is decided by the interrupt interval of Basic Interval Timer and the contents of WDTR.

$$\text{The interval of WDT} = \text{The contents of WDTR} \times \text{The interval of B.I.T.}$$

**Caution) Do not use the contents of WDTR = "0"**

- ◆ The relationship between the input clock of B.I.T and the output of W.D.T. (@8MHz)

BTS2	BTS1	BTS0	B.I.T. Input Clock	The cycle of B.I.T.	The cycle of W.D.T.(max)
0	0	0	PS4 ( 2 $\mu$ S )	512 $\mu$ S	32,256 $\mu$ S
0	0	1	PS5 ( 4 $\mu$ S )	1,024 $\mu$ S	64,512 $\mu$ S
0	1	0	PS6 ( 8 $\mu$ S )	2,048 $\mu$ S	129,024 $\mu$ S
0	1	1	PS7 ( 16 $\mu$ S )	4,096 $\mu$ S	258,048 $\mu$ S
1	0	0	PS8 ( 32 $\mu$ S )	8,192 $\mu$ S	516,096 $\mu$ S
1	0	1	PS9 ( 64 $\mu$ S )	16,384 $\mu$ S	1,032,192 $\mu$ S
1	1	0	PS10 ( 128 $\mu$ S )	32,768 $\mu$ S	2,064,384 $\mu$ S
1	1	1	PS11 ( 256 $\mu$ S )	65,536 $\mu$ S	4,128,768 $\mu$ S

### 2.5.2. The output of WDT signal

The overflow of WDT can be output through R54/WDT O port by setting bit4 of PMR5(WDTS) to "1".

#### ■ PORT R5 MODE REGISTER

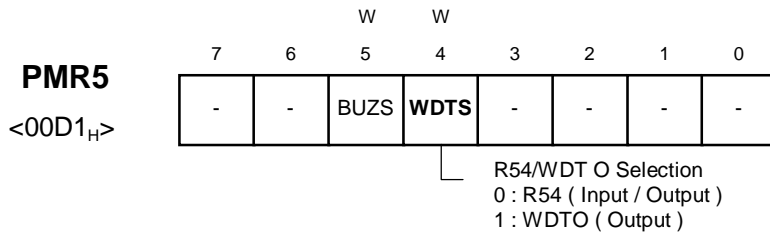

### 2.6. TIMER

The GMS81508/16 has four multi-functional 8-bit binary timers(Timer0~Timer3).

Timer0 (or Timer2) is can be used as a 16-bit timer/event counter with Timer1(or Timer3). The Timer0-1 and Timer2-3 have same functions and structures. So, We will explains about Timer0 and Timer1 only.

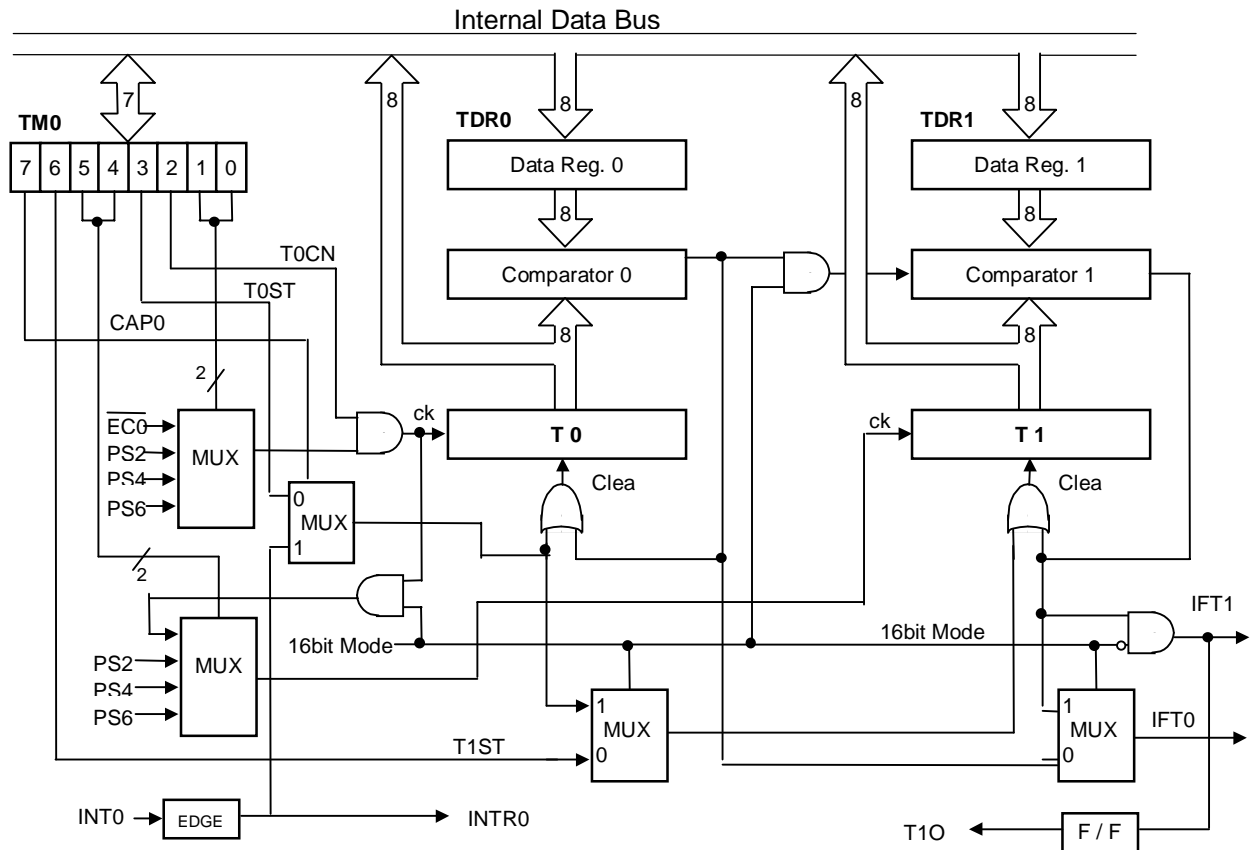

■ Operation Mode of Timer

Timer0,Timer2	Timer1,Timer3
- 8-bit Interval Timer	- 8-bit Interval Timer
- 8-bit Event Counter	- 8-bit rectangular pulse output
- 8-bit input capture	
- 16-bit Interval Timer	
- 16-bit Event Counter	
- 8-bit rectangular pulse output	

■ TIMER MODE REGISTER 0,2(TM0, TM2)

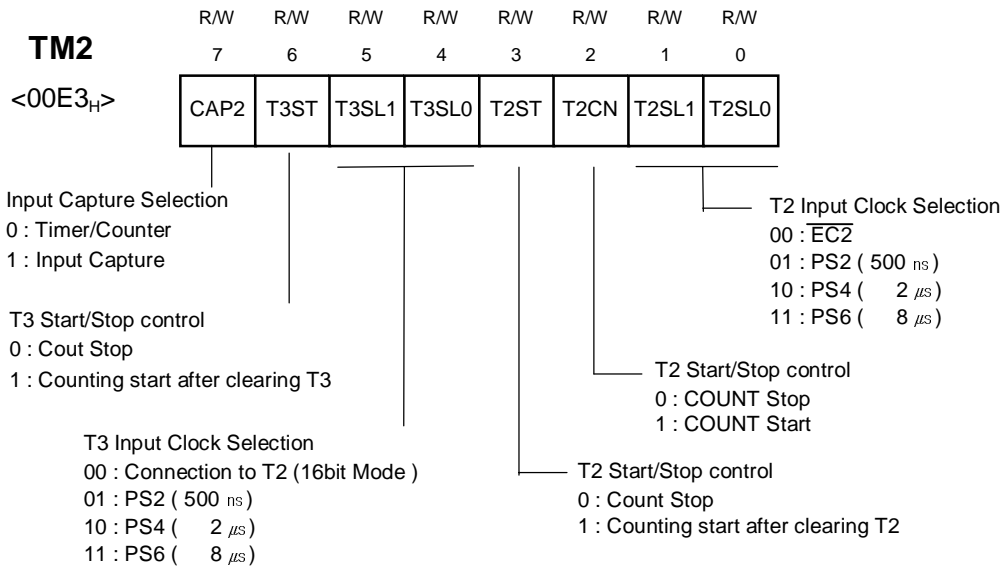
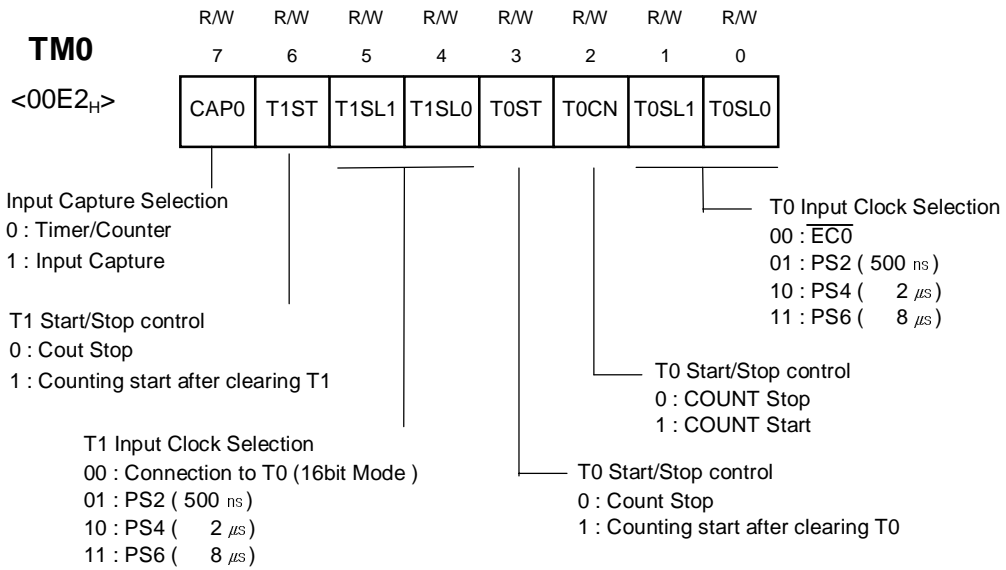

■ TIMER DATA REGISTER(TDR0 ~ TDR3)

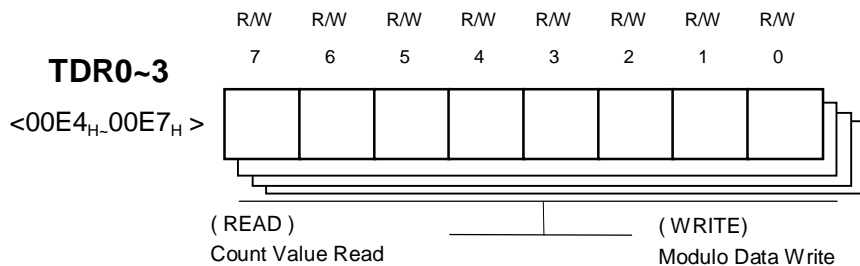

### 2.6.1. Control of Timer

T0 ( T1 ) consists of 8-bit Binary Up-Counter. When the counting value of Timer0 , Timer1 and Timer0-1(16bit) become equal to the contents of Timer Data Register(TDR0,TDR1,TDR0-1) value, the counter is cleared to "00H" and restarts count-up operation. At this time, Interrupt request (IFT0 or IFT1) is generated.

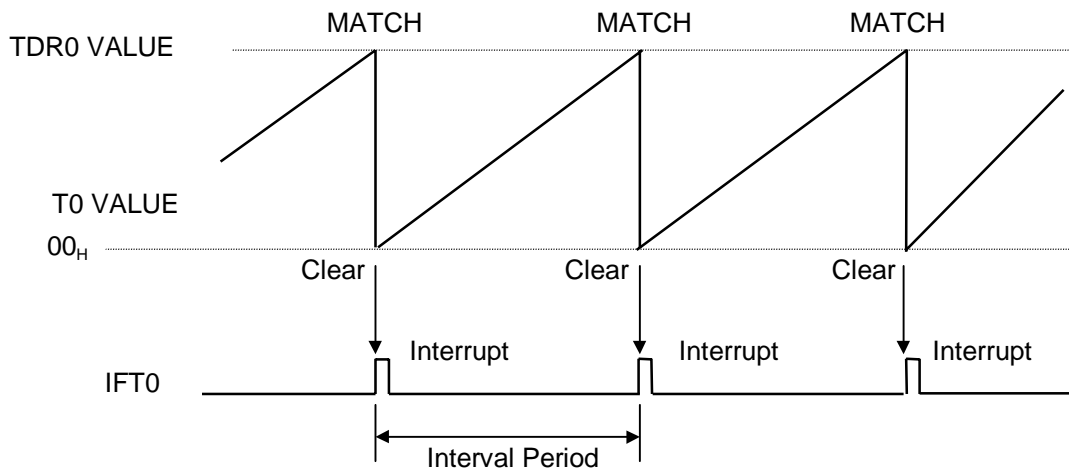

Any of the PS2, PS4, PS6 or external clock can be selected as the clock source of T0 by bit1(T0SLI) and bit0(T0SL0) of TM0. Any of the PS2, PS4, PS6 or overflow of T0 can be selected as the clock source of T1 by bit5(T1SL1) and bit4(T1SL0) of TM0. When the overflow of T0 is selected as input clock of T1, Timer0-1 operates as 16-bit timer. In this case, Timer0-1 only is controlled by T0ST,T0CN and the interrupt vector is Timer0 vector.

The operation of T0, T1 is controlled by bit3(T0ST), bit2(T0CN) and bit6(T1ST) of TM0. T0CN controls count stop/start without clearing counter. T0ST and T1ST control count stop/start after timer clear. In order to enable count-up of timer, T0CN, T0ST and T1ST should become "1". In order to start count-up after clearing of counter, T0ST or T1ST should be set to "1" after set to "0" temporarily.

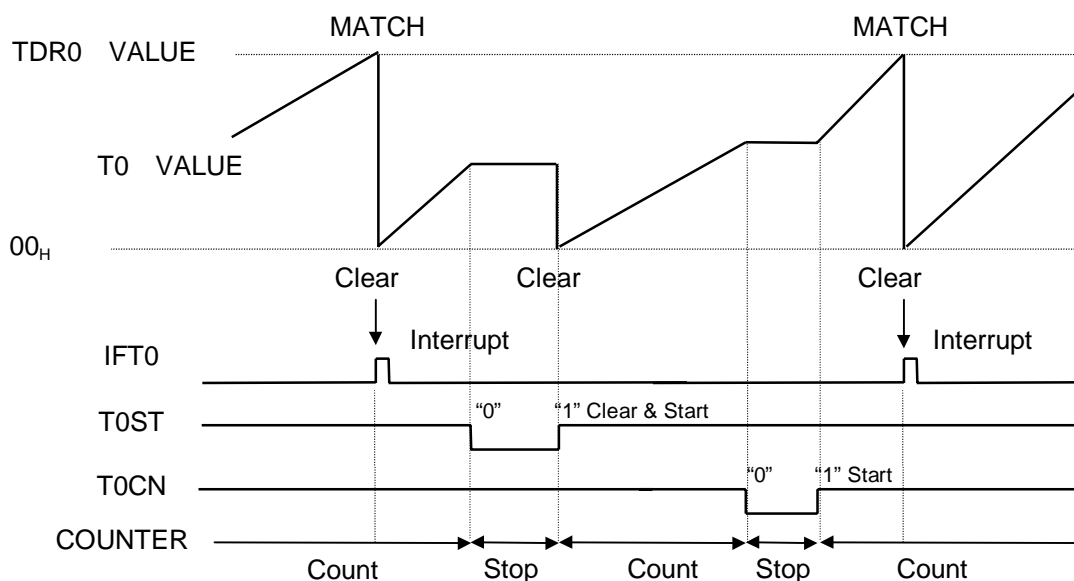

By read Timer Data Register(TDR0~3),The counting value of timer can be read at any time.

### 2.6.2. Interval Timer

The interrupt cycle is determined by the source clock of timer and the contents of TDR.

$$\text{Interrupt cycle} = \text{source clock} \times \text{the contents of TDR}$$

In order to write data to TDR, you have to stop timer. otherwise, TDR value is invalid.

◆ Maximum Interrupt Cycle according to source clock @ fex=8MHz

	8-bit TIMER Mode		16-bit TIMER Mode	
	source clock	max. count	source clock	max. count
T0,T2	PS2 ( 0.5 $\mu$ S )	128 $\mu$ S	PS2 ( 0.5 $\mu$ S )	32,768 $\mu$ S
	PS4 ( 2 $\mu$ S )	512 $\mu$ S	PS4 ( 2 $\mu$ S )	131,072 $\mu$ S
	PS6 ( 8 $\mu$ S )	2,048 $\mu$ S	PS6 ( 8 $\mu$ S )	524,288 $\mu$ S
T1,T3	PS2 ( 0.5 $\mu$ S )	128 $\mu$ S		
	PS4 ( 2 $\mu$ S )	512 $\mu$ S		
	PS6 ( 8 $\mu$ S )	2,048 $\mu$ S		

### 2.6.3. Event Counter

The event counter operates in the same way as the interval timer except it counts the external event input from R44/EC0 and R45/EC1 port. it only counts at the falling edge of event input clock.

In order to input of external event clock, the relevant Port Mode Register(bit4,bit5 of PMR4) is set to "1". TDR value should be initialized to "FFH" because timer is cleared when it equals to TDR value, but if you want to use interrupt, TDR value should be written to "1H~FFH".

### 2.6.4. Pulse Output

A pulse width 50% cycle duty is output to the R46/T1 O or R47/T3 O port and reverse the output when timer interrupt is generated. This creates a pulse period which is two times that of the timer interrupt cycle. The output pulse period is determined by the source clock of timer and the contents of TDR.

$$\text{output period} = \text{source clock}(\mu\text{S}) \times \text{the contents of TDR} \times 2$$

In order to output of pulse, the bit6,bit7 of PMR4 is set to "1".

### 2.6.5. Input Capture

This function measures the period or width of pulse input from external INT. (R40/INT0, R42/INT2) port. The period of pulse is measured by selecting rising edge or falling edge of the interrupt edge select register(IEDS) and the width of pulse is measured by selecting both edge of IEDS.

The external interrupt is generated at the valid edge according to IEDS. At this time, The counting value of timer is loaded into TDR and counter is cleared and restarts count-up.

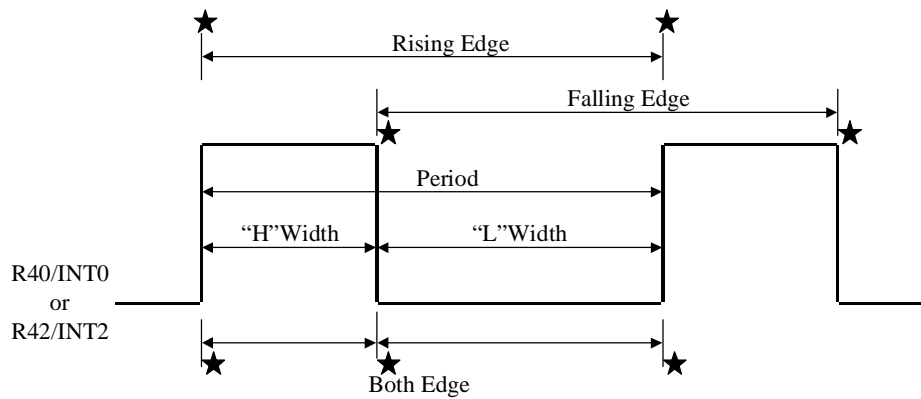

★ **Timer Operation**  
the counting value of timer is latched  
↓  
timer is cleared to 00H  
↓  
timer restart count-up

■ **PORT R4 MODE REGISTER**

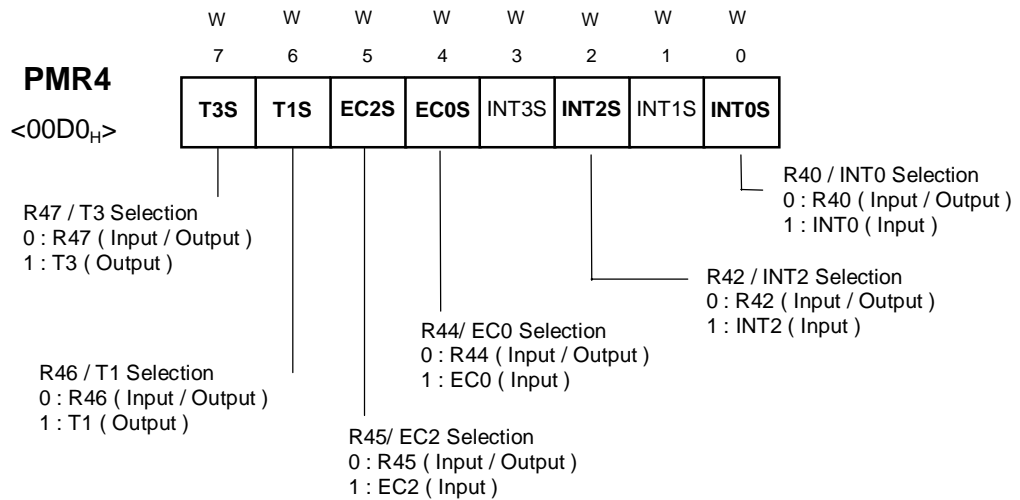

### 2.7. EXTERNAL INTERRUPT

An interrupt request is generated when a level-change from "H" to "L" or "L" to "H" of INT0,INT1,INT2,INT3 pin is detected. The edge of external interrupt is selected by interrupt edge selection register(IEDS) and ports(R40,R41,R42,R43) corresponding to INT0,INT1,INT4,INT3 are determined as a input port for external interrupt by bit0~3 of port4 mode register(PMR4).

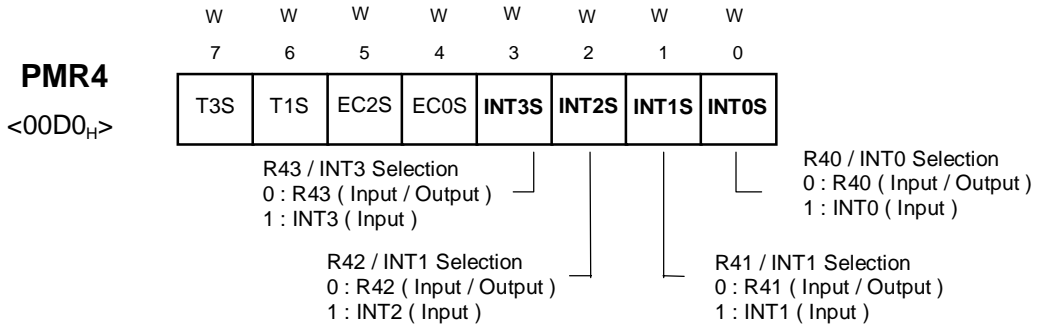

#### ■ EXT. INTERRUPT EDGE SELECTION REGISTER

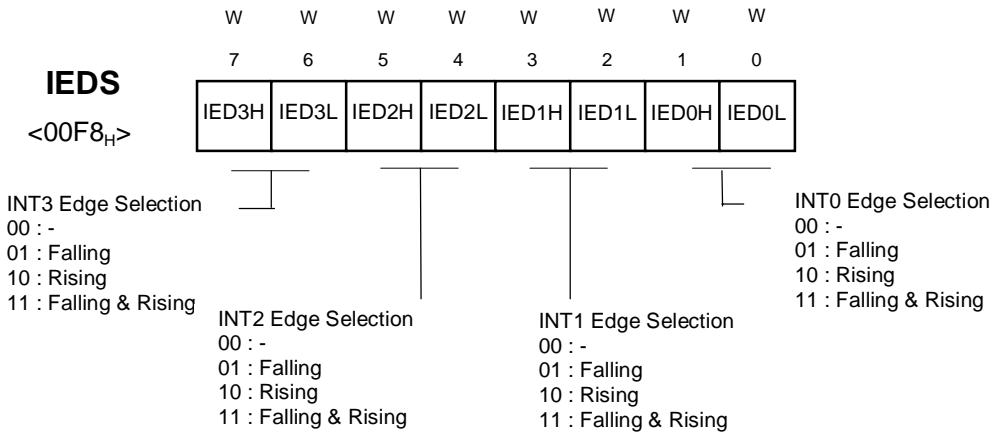

## 2.8. A/D CONVERTER

A/D Converter has an 8-bit resolution, and input is possible up to 8 channel.

A/D Converter consists of Analog Input Multiplexer, A/D convert Mode Register, Resistance Ladder, Sample and Holder, Successive Approximation Circuit and A/D Conversion Data Register.

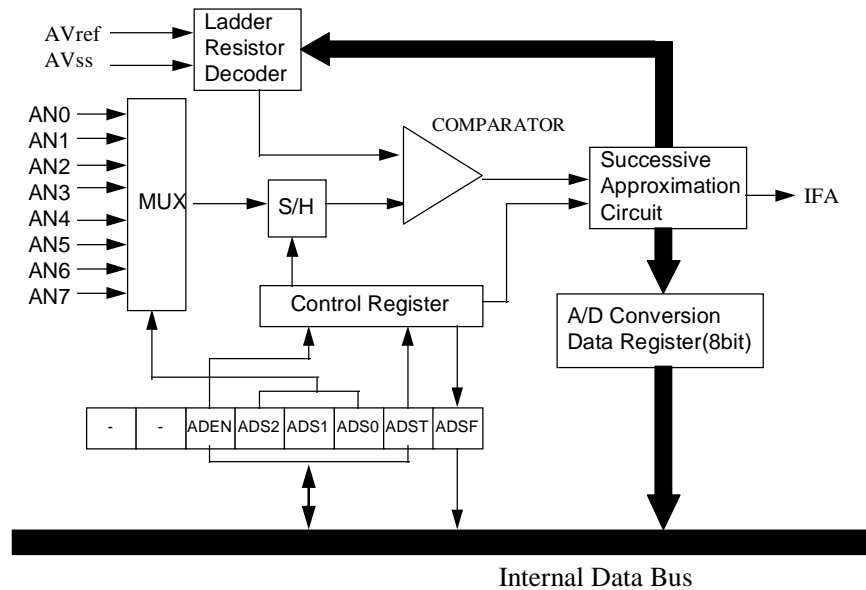

### 2.8.1. Control of A/D Converter

The analog input is selected by bit2~4 of A/D Converter Mode Register(ADCM). This bits chooses among AN0~AN7. The other analog pins which are not used not A/D conversion be used as normal port.

The A/D Conversion is started by setting A/D Conversion Start bit (ADST) to "1"(only for ADEN=1). After A/D Conversion is started, ADST is cleared by hardware. During A/D Conversion, when ADST is set to "1", A/D Conversion starts again from the beginning.

The analog input voltage and the reference voltage are compared and the result is stored in the A/D Converter Data Register(ADR) and ADSF(bit0 of ADCM) is set to "1". The A/D interrupt request is generated at the completion of A/D conversion.

The result of the conversion is obtained by reading out the A/D register(ADR).



■ A/D CONVERTER MODE REGISTER(ADCM)

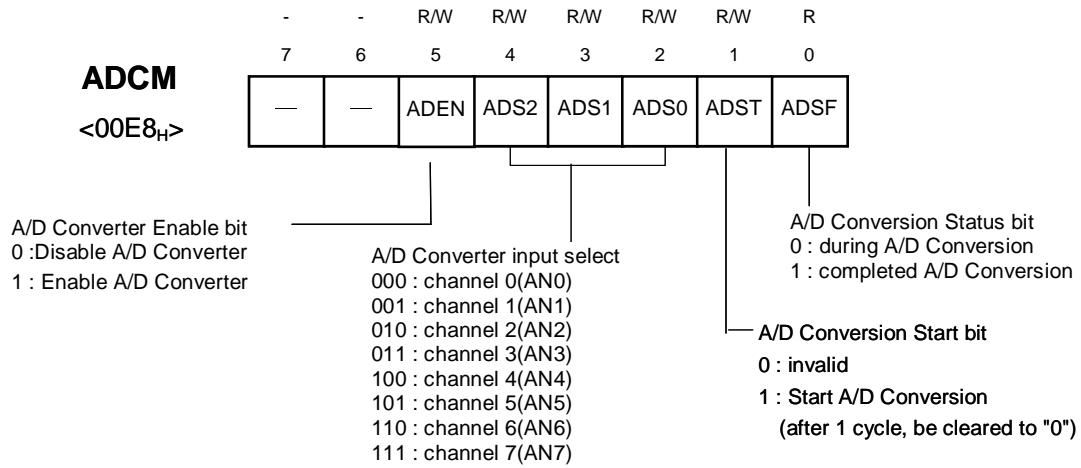

■ A/D CONVERTER DATA REGISTER(ADR)

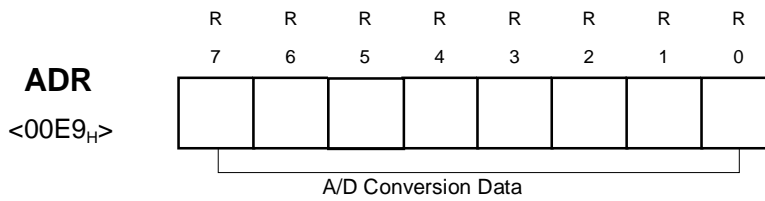

## 2.9. SERIAL I/O

The serial I/O is 8-bit clock synchronous type and consists of serial I/O register, serial I/O mode register, clock selection circuit octal counter and control circuit.

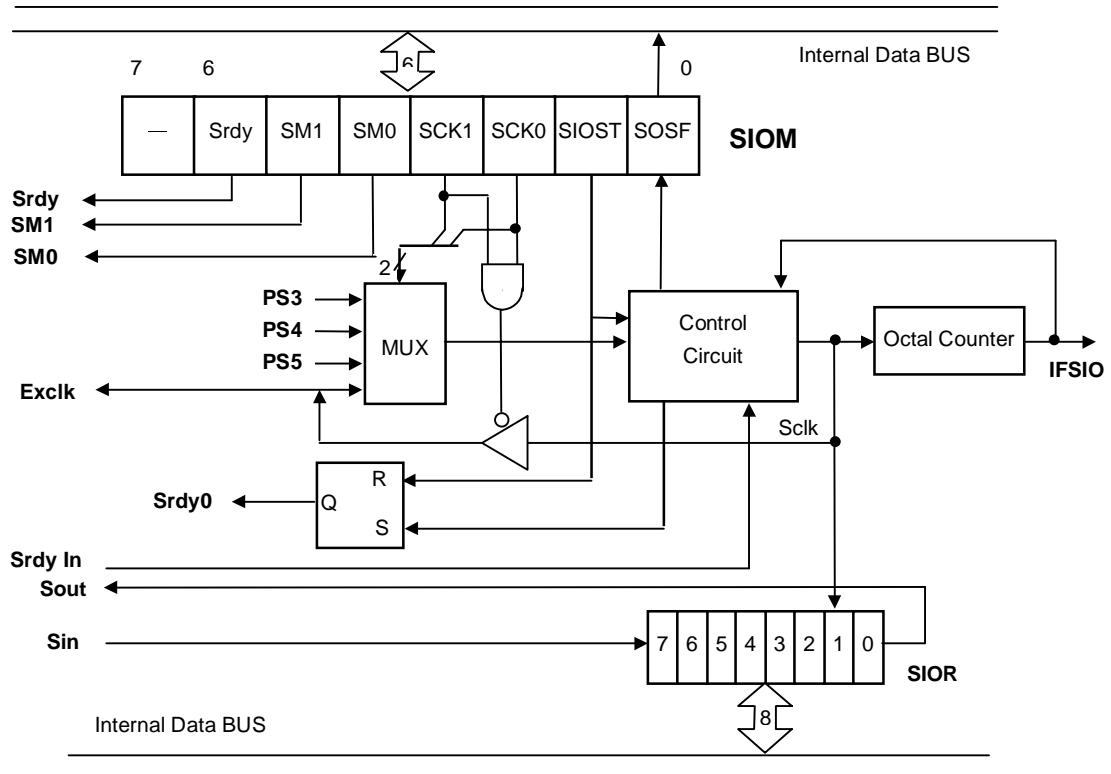

■ Serial I/O Mode Register

This register controls serial I/O function. According to SCK1 and SCK0, the internal clock or external clock can be selected.

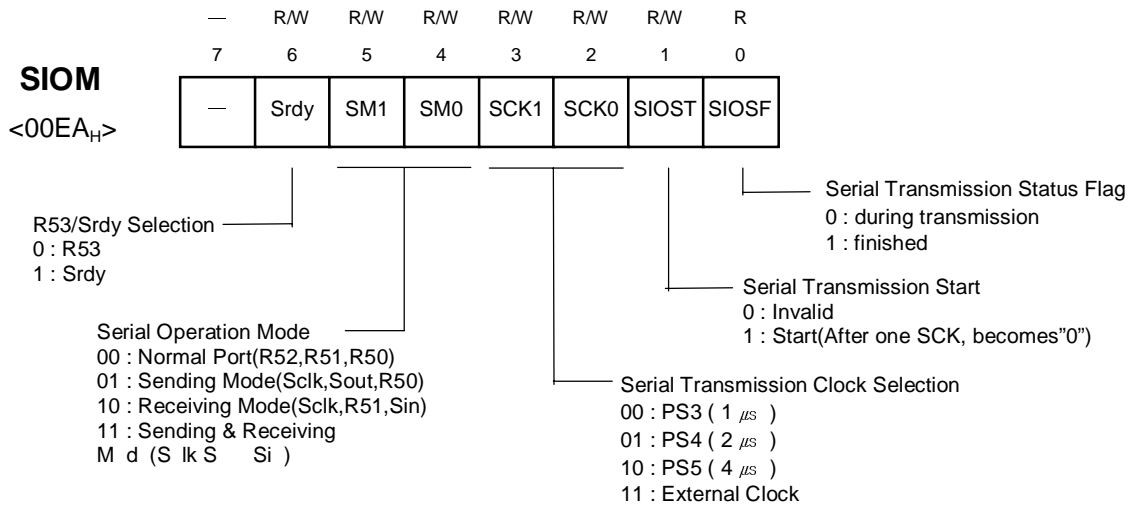

■ Serial I/O Data Register

The Serial I/O Data Register (**SIOR**) is a 8-bit shift register. First LSB is send or is received.

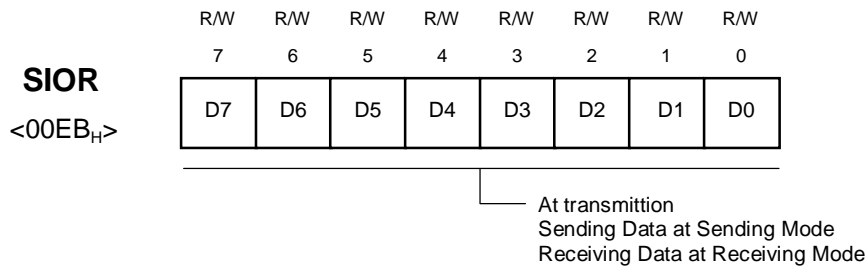

### 2.9.1. Data Transmission/Receiving Timing

The serial transmission is started by setting SIOST(bit1 SIOM) to "1". After one cycle of SCK, SIOST is cleared automatically to "0". The serial output data from 8-bit shift register is output at falling edge of Sclk. and input data is latched at rising edge of Sclk. When transmission clock is counted 8 times, serial I/O counter is cleared as "0". Transmission clock is halted in "H" state and serial I/O interrupt (IFSIO) occurred.

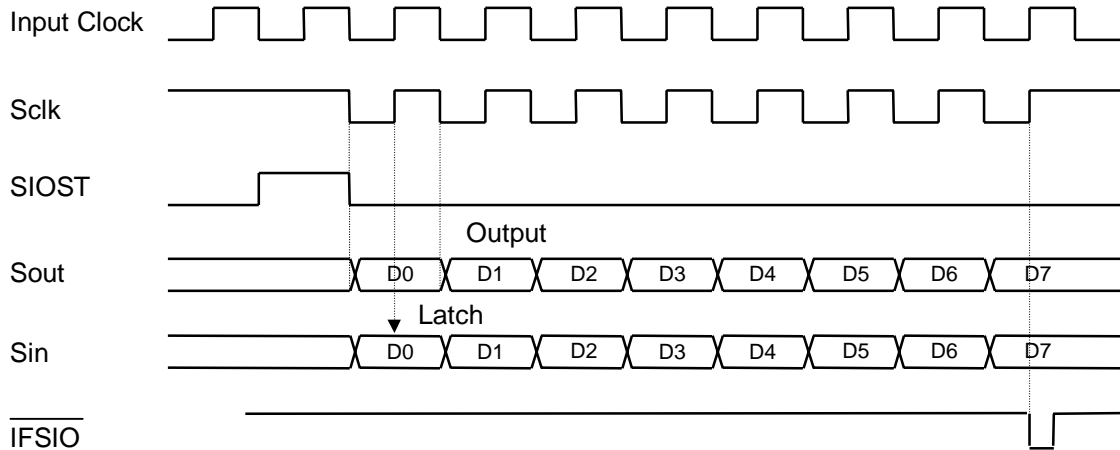

Timing Diagram of Serial I/O

### 2.9.2. The Serial I/O operation by Srdy pin

- transmission clock = external clock

The  $\overline{\text{Srdy}}$  pin becomes "L" by SIOST = "1". This signal tells to the external system that this device is ready for serial transmission. The external system detects the "L" signal and starts transmission. The  $\overline{\text{Srdy}}$  pin becomes "H" at the first rising edge of transmission clock.

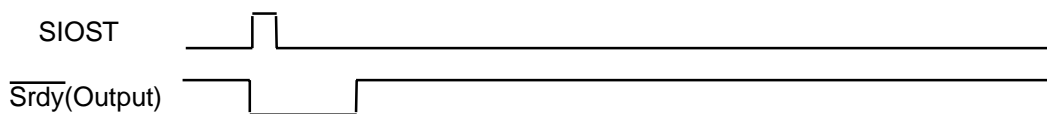

- transmission clock = internal clock

The I/O of  $\overline{\text{Srdy}}$  pin is input mode. When the external system is ready for serial transmission, the "L" level is inputted at this pin. At this time this device starts serial transmission.

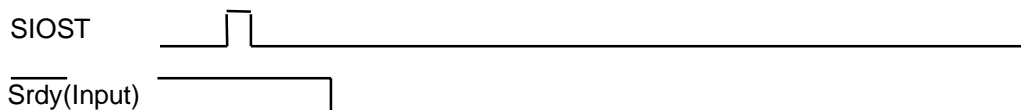

**2.9.3. The method of Serial I/O**

- ① Select transmission/receiving mode  
<Notice> When external clock is used, the frequency should be less than 1MHz and recommended duty is 50%.
- ② In case of sending mode, write data to be send to SIOR.
- ③ Set SIOST to “1” to start serial transmission.  
<Notice > If both transmission mode is selected and transmission is performed simultaneously it would be made error.
- ④ The SIO interrupt is generated at the completion of SIO and SIOSF is set to “1”. In SIO interrupt service routine, correct transmission should be tested.
- ⑤ In case of receiving mode, the received data is acquired by reading the SIOR.

**2.9.4. The Method to Test Correct Transmission with S/W**

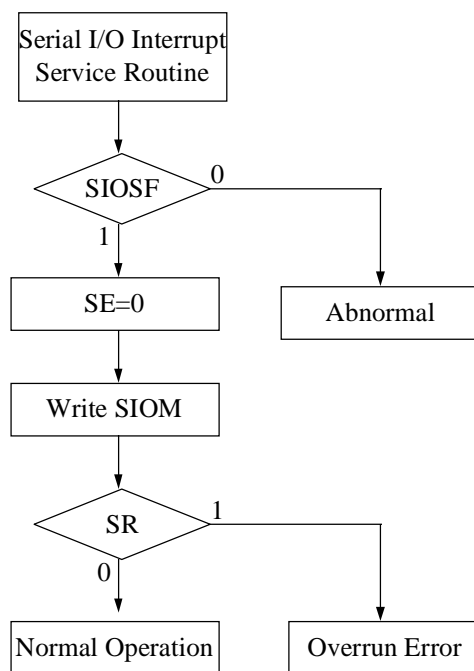

**Serial Method to Test Transmission.**

**Note)** SE: Interrupt Enable Regist Low IENL ( Bit3 )  
SR : Interrupt Request Flag Regist Low IRQL ( Bit3 )

## 2.10. PWM

PWM(Pulse Width Modulation) has a 8-bit resolution and the PS8,PS9,PS10,PS11 of the prescaler can be selected as input clock PWM.

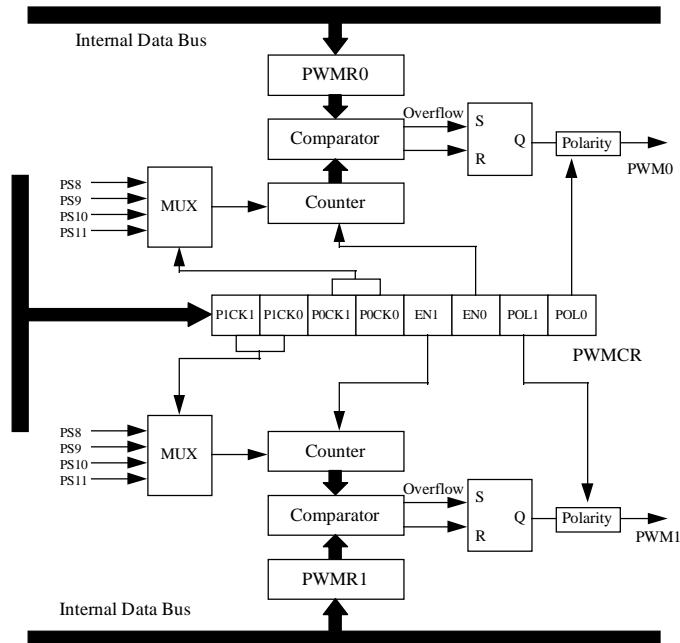

### 2.10.1. Controls of PWM

The input clock is selected by PWM Control Register (PWMCR), and the width of pulse is determined by the PWM Register (PWMR).

The pulse period according to input clock are as follows.

Input clock	PWM Period
PS8 (32 $\mu$ s)	8,192 $\mu$ s
PS9 (64 $\mu$ s)	16,384 $\mu$ s
PS10 (128 $\mu$ s)	32,768 $\mu$ s
PS11 (256 $\mu$ s)	65,536 $\mu$ s

Bit2 (EN0) and bit3 (EN1) of PWM control Register (PWMCR) determine the operation channel of PWM. When EN0=0 and EN1=0, PWM does not executed. The EN0 and EN1 are Enable bit of PWM channel 0 and channel 1 respectively. When EN0=1, PWM channel0 executes. When EN1=1, PWM channel1 executes.

POL0 and POL1 are a polarity control bit of channel0 and channel1. When they are 0, LOW active. When 1, HIGH active. PWMCR becomes "00h" in reset state.

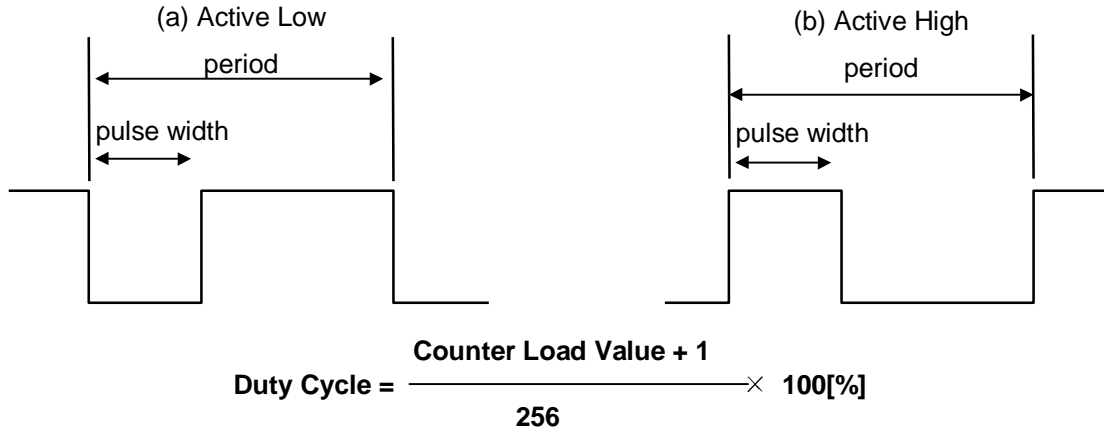

■ PWM CONTROL REGISTER

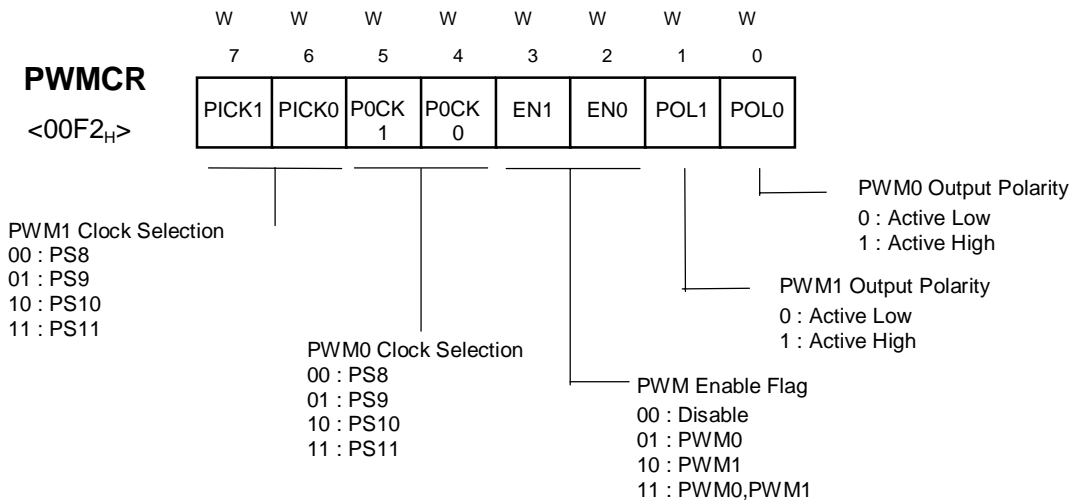

■ PWM DATA REGISTER

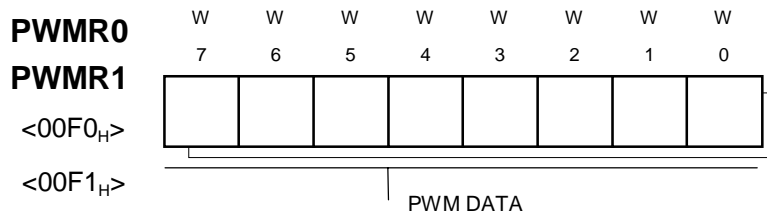

### 2.11. BUZZER DRIVER

Buzzer driver consist of 6 bit binary counter, Buzzer Register(BUR), and selector of clock. The wide range frequency(500Hz~250KHz) can be generated using programmable counter. PORT R55 is assigned for output port of Buzzer Driver by setting bit5 of PMR5(\$00D1H) to "1".

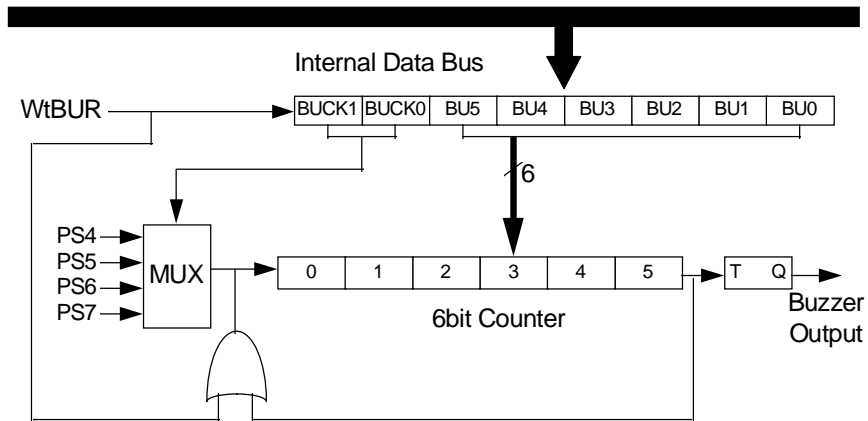

#### ■ PORT R5 MODE REGISTER

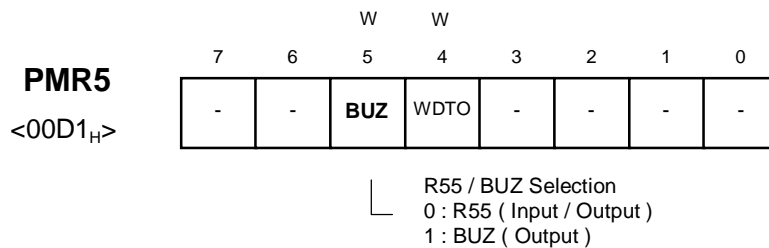

#### ■ BUZZER DATA REGISTER

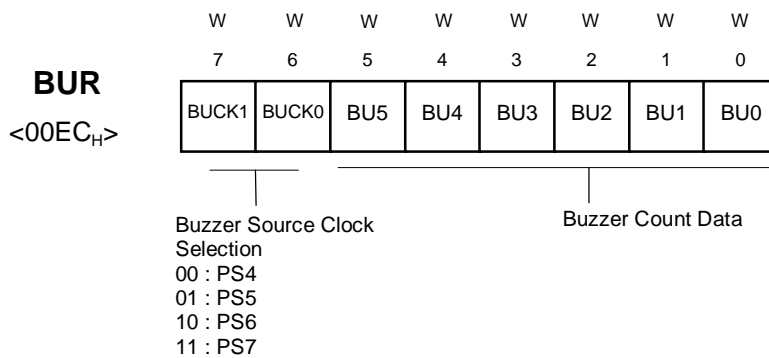



### 2.11.1. Buzzer Driver Operation

The bit0-5 of Buzzer Register (BUR) determines output frequency for buzzer driving. The frequency is calculated as shown bellows.

$$N = \text{BUR data}$$

$$\text{freq.} = 1/(\text{source clock} \times N \times 2)$$

The bit6 and bit7 of Buzzer register (BUR) selects the source clock of the buzzer counter among PS4 (2us), PS5 (4us), PS6 (8us) and PS7 (16us).

The buzzer counter is cleared by Wt signal of BUR and starts the counting. also, It is cleared by counter overflow, and continues count-up to output the rectangular wave of duty 50%.

\* Caution: don't use BUR register as 00H. (counter reset state)

◆ The output frequency of buzzer according to Buzzer Register bit5 - bit0 (fex = 8 MHz)

REG. LOAD DEC	REG. LOAD HEX	OUTPUT FREQUENCY[KHz]				REG. LOAD DEC	REG. LOAD HEX	OUTPUT FREQUENCY[KHz]			
		PS4 (2us)	PS5 (4us)	PS6 (8us)	PS7 (16us)			PS4 (2us)	PS5 (4us)	PS6 (8us)	PS7 (16us)
1	01	250	125	62.5	31.25	33	21	7.576	3.788	1.894	0.947
2	02	125	62.5	31.25	15.626	34	22	7.352	3.676	1.838	0.919
3	03	83.333	41.666	20.834	10.416	35	23	7.142	3.571	1.786	0.893
4	04	62.5	31.25	15.626	7.812	36	24	6.944	3.472	1.736	0.868
5	05	50	25	12.5	6.25	37	25	6.756	3.378	1.689	0.845
6	06	41.666	20.834	10.416	5.208	38	26	6.578	3.289	1.645	0.822
7	07	35.714	17.858	8.928	4.464	39	27	6.41	3.205	1.602	0.801
8	08	31.25	15.626	7.812	3.906	40	28	6.3	3.125	1.563	0.781
9	09	27.778	13.888	6.944	3.472	41	29	6.098	3.049	1.524	0.762
10	0A	25	12.5	6.25	3.126	42	2A	5.952	2.976	1.488	0.744
11	0B	22.728	11.364	5.682	2.84	43	2B	5.814	2.907	1.453	0.727
12	0C	20.834	10.416	5.682	2.604	44	2C	5.682	2.841	1.421	0.710
13	0D	19.23	9.616	4.808	2.404	45	2D	5.556	2.778	1.389	0.694
14	0E	17.858	8.928	4.464	2.232	46	2E	5.434	2.717	1.359	0.679
15	0F	16.666	8.334	4.166	2.084	47	2F	5.32	2.660	1.33	0.665
16	10	15.626	7.812	3.906	1.9541	48	30	5.208	2.604	1.302	0.651
17	11	14.706	7.352	3.676	1.838	49	31	5.102	2.551	1.276	0.638
18	12	13.888	6.944	3.472	1.736	50	32	5	2.5	1.25	0.625
19	13	13.158	6.579	3.288	1.644	51	33	4.902	2.451	1.225	0.613
20	14	12.5	6.25	3.124	1.562	52	34	4.808	2.404	1.202	0.601
21	15	11.904	5.952	2.976	1.488	53	35	4.716	2.358	1.179	0.590
22	16	11.364	5.682	2.840	1.420	54	36	4.63	2.315	1.157	0.579
23	17	10.87	5.434	2.718	1.358	55	37	4.546	2.273	1.136	0.568
24	18	10.416	5.208	2.604	1.302	56	38	4.464	2.232	1.116	0.558
25	19	10	5	2.5	1.250	57	39	4.386	2.193	1.096	0.548
26	1A	9.616	4.808	2.404	1.202	58	3A	4.31	2.155	1.078	0.539
27	1B	9.26	4.630	2.314	1.158	59	3B	4.238	2.119	1.059	0.530
28	1C	8.928	4.464	2.232	1.116	60	3C	4.166	2.083	1.042	0.521
29	1D	8.62	4.310	2.156	1.078	61	3D	4.098	2.049	1.025	0.512
30	1E	8.334	4.166	2.084	1.042	62	3E	4.032	2.016	1.008	0.504
31	1F	8.064	4.032	2.016	1.008	63	3F	3.968	1.984	0.992	0.496
32	20	7.812	3.906	1.954	0.976						

## 2.12. INTERRUPTS

The interrupts are usually used when the processing routine has the higher priority than on-going program and a routine must be executed at specific interval.

### 2.12.1. Interrupt Circuit Configuration and Kinds

GMS81508/16 Interrupt circuits consist of Interrupt Enable Register (IENH,IENL), Interrupt Request Register (IRQH,IRQL), priority circuit and selecting circuit.

The configuration of Interrupt circuit is shown in below.

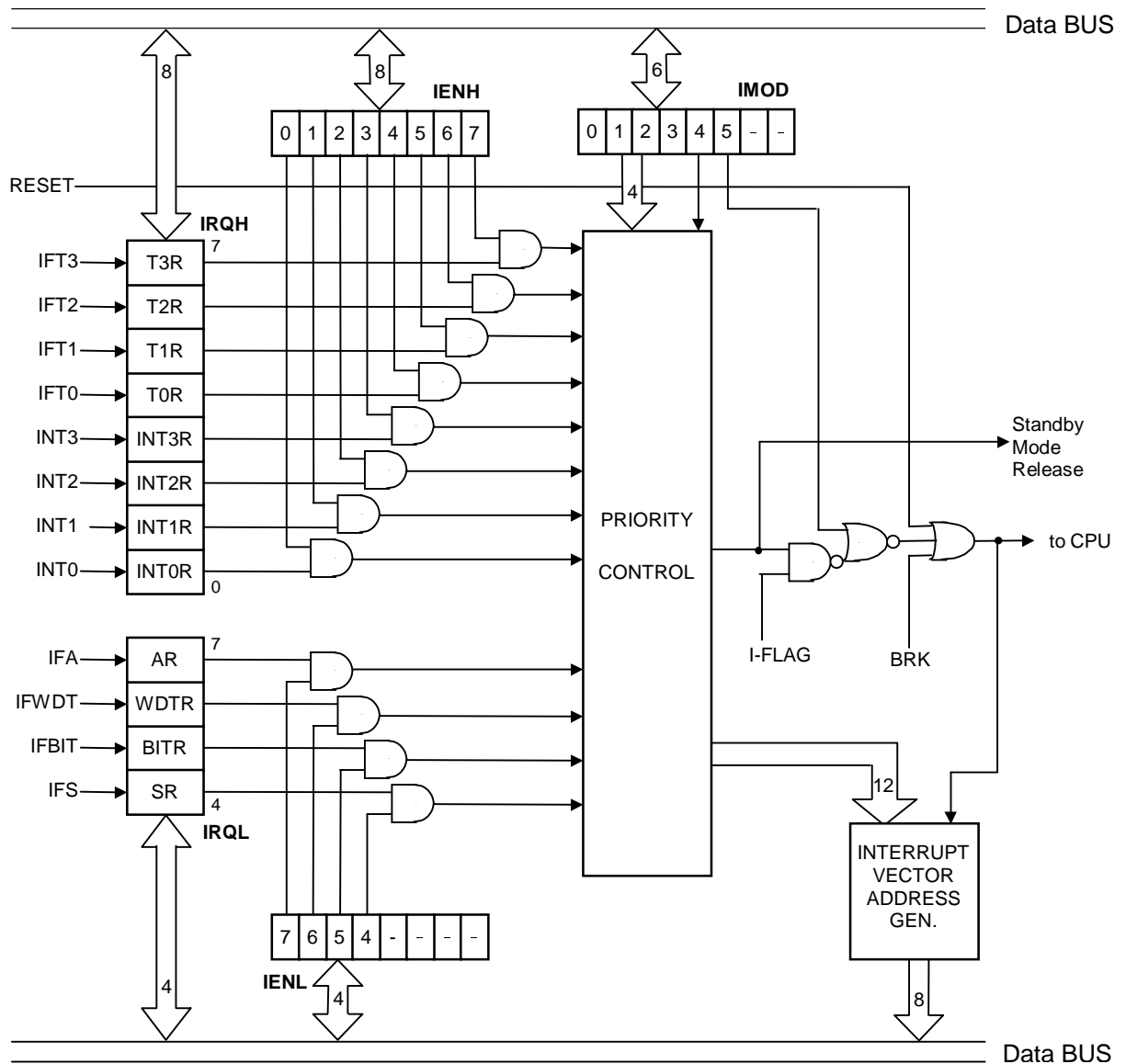

■ **Interrupt Source**

The interrupts sources are external interrupt source(INT0, INT1,INT2,INT3), peripheral function source (T0,T1,T2,T3,B.I.T.,W.D.T.,SIO,A/DC) and software interrupt source(BRK).

After reset input(RESET), the program is executed from the address in reset vector table like general interrupts.

Type	Mask	Priority	Interrupt Request Source	Vector H	Vector L
H/W Interrupt	Non Maskable	1	RST Reset Pin	FFFF <sub>H</sub>	FFFE <sub>H</sub>
		2	INT0R External Interrupt 0	FFFB <sub>H</sub>	FFFA <sub>H</sub>
		3	INT1R External Interrupt 1	FFF9 <sub>H</sub>	FFF8 <sub>H</sub>
		4	INT2R External Interrupt 2	FFF7 <sub>H</sub>	FFF6 <sub>H</sub>
		5	INT3R External Interrupt 3	FFF5 <sub>H</sub>	FFF4 <sub>H</sub>
		6	T0R Timer 0	FFF3 <sub>H</sub>	FFF2 <sub>H</sub>
		7	T1R Timer 1	FFF1 <sub>H</sub>	FFF0 <sub>H</sub>
		8	T2R Timer 2	FFEF <sub>H</sub>	FFEE <sub>H</sub>
		9	T3R Timer 3	FFED <sub>H</sub>	FFEC <sub>H</sub>
		10	AR A/D Converter	FFEB <sub>H</sub>	FFEA <sub>H</sub>
		11	WDTR Watch Dog Timer	FFE9 <sub>H</sub>	FFE8 <sub>H</sub>
		12	BITR Basic Interval Timer	FFE7 <sub>H</sub>	FFE6 <sub>H</sub>
		13	SR Serial I/O	FFE5 <sub>H</sub>	FFE4 <sub>H</sub>
S/W Interrupt	Non Maskable	—	BRK Break Instruction	FFDF <sub>H</sub>	FFDE <sub>H</sub>

**2.12.2. Interrupt Control**

The interrupts is controlled by the interrupt master enable flag I-Flag(3'rd bit of PSW), interrupt enable register(IENH,IENL), interrupt request register(IRQH,IRQL) except RESET and S/W interrupt.

■ **Interrupt Enable Register ( IENH, IENL)**

This register is composed of interrupt enable flags of each interrupt source, this flags determines whether an interrupt will be accepted or not. when enable flag is "0", an interrupt corresponding interrupt source is prohibited.

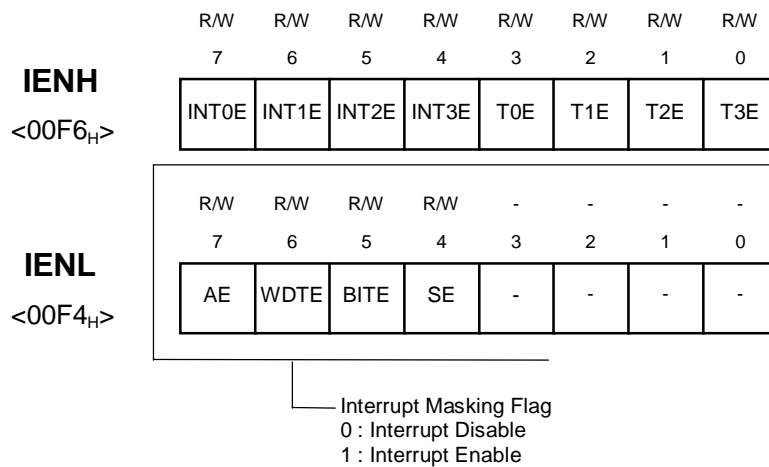

#### ■ Interrupt Request Flag Register ( **IRQH**, **IRQL** )

Whenever interrupt request is generated, the interrupt request flag is set. The request flag maintains '1' until interrupt is accepted. The accepted interrupt request flag is automatically cleared by interrupt process cycle. Interrupt Request Flag Register ( **IRQH**, **IRQL** ) is Read/ Write Register. So, it is possible to be checked and changed by program.

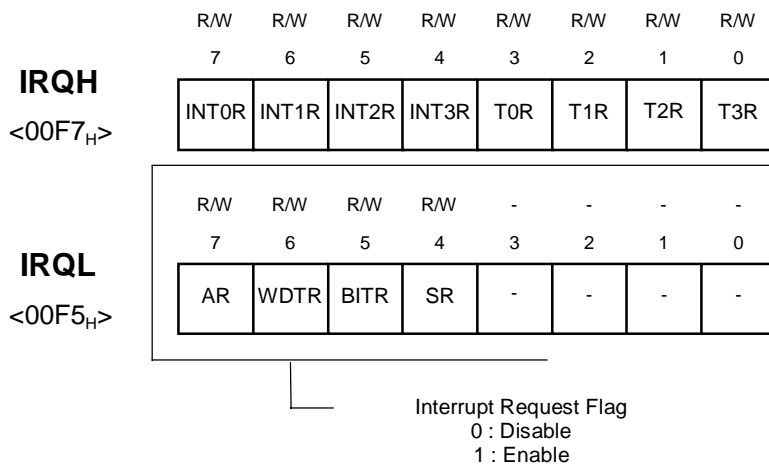

### 2.12.3. Interrupt Priority

When two or more interrupts requests are generated at the same sampling point, the interrupt having the higher priority is accepted. The interrupt priority is determined by H/W. however, multiple priority processing through software is possible by using interrupt control flags(IENH, IENL, I-flag) and interrupt mode register(IMOD).

**2.12.4. Interrupt Sequence**

When interrupt is accepted, the on-going process is stopped and the interrupt service routine is executed. After the interrupt service routine is completed it is necessary to restore everything to the state before the interrupt occurred.

As soon as an interrupt is accepted, the contents of the program counter and the program status word are saved in the stack area. At the same time, the contents of the vector address corresponding to the accepted interrupt, which is in the interrupt vector table, enters into the program counter and interrupt service routine is executed.

In the interrupt service routine, the corresponding interrupt request flag is cleared and interrupt master enable flag(I-flag) becomes "0", thereby another interrupts are not accepted before I-flag is set to "1" by program.

In order to execute the interrupt service routine, it is necessary to write the jump address(the first address of the interrupt service routine) in vector table corresponding to each interrupt.

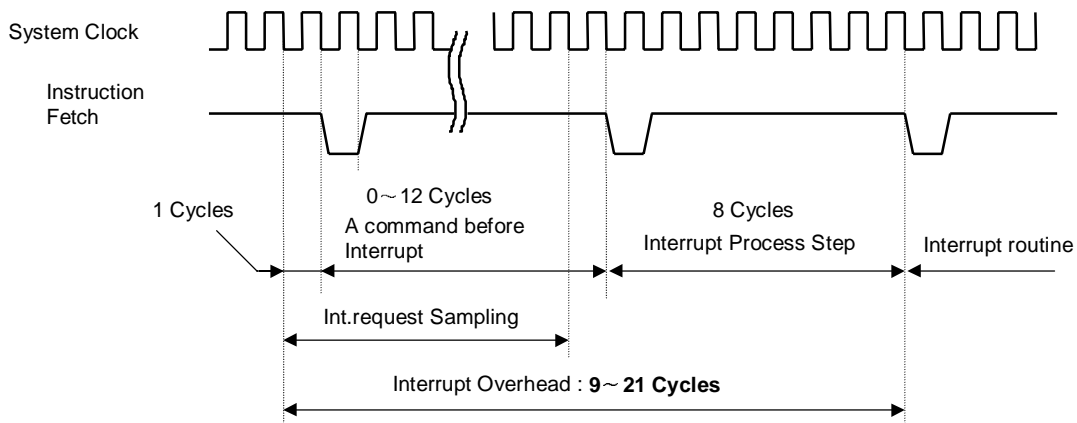

◆ **Interrupt Accept Timing**

- The valid timing after executing Interrupt control Flag
  - ⓐ I-Flag is valid, after EI, DI executed
  - ⓑ IENH, IENL register is valid after next instruction

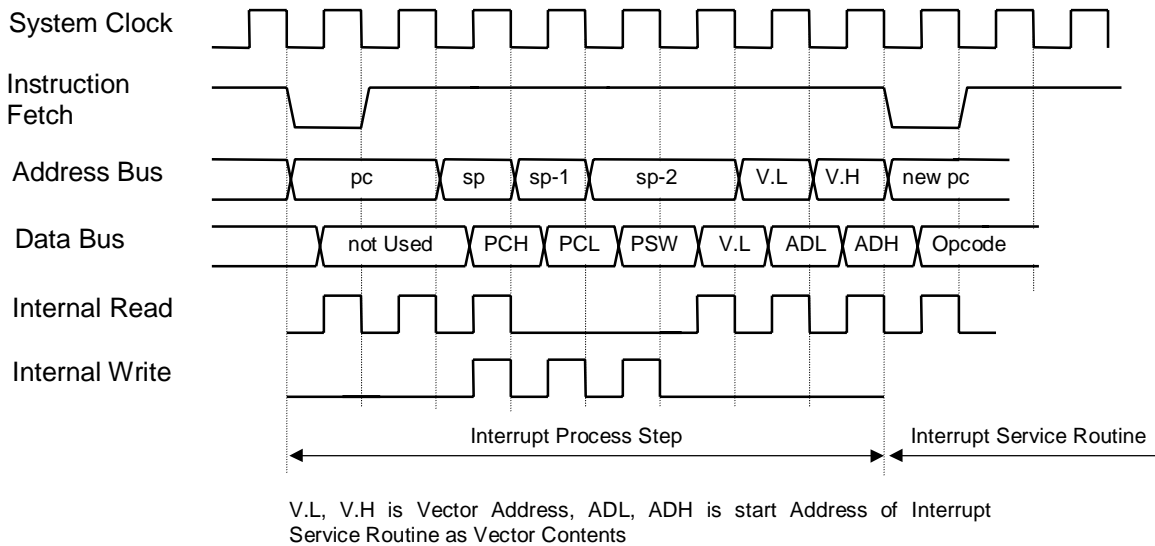

◆ **Interrupt Process Step Timing**

2.12.5. Software Interrupt

The interrupt is the lowest priority order software interrupt by BRK instruction. B-flag is set.

Interrupt vector of BRK instruction is shared with the vector of TCALL 0. Each processing step is determined by B-Flag as a below.

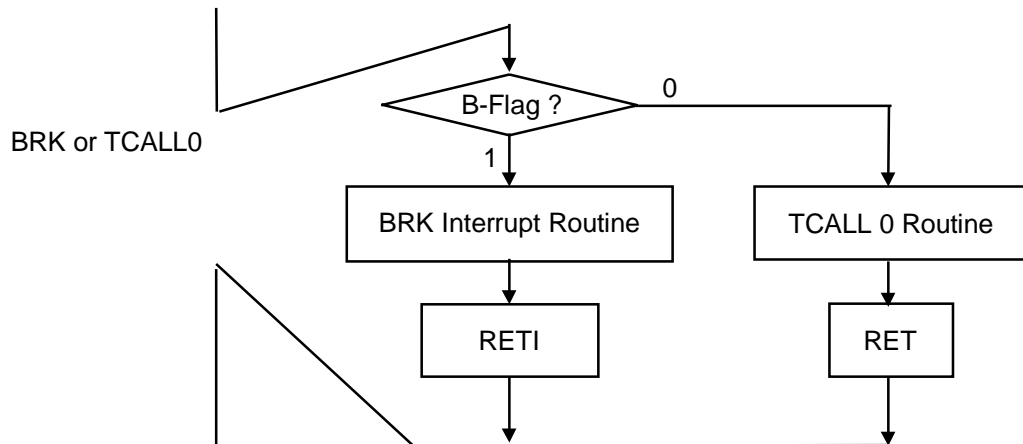

◆ **Execution of BRK/ TCALL0**

### 2.12.6. Multiple Interrupt

When an interrupt is accepted, and program flow goes to the interrupt service routine. The interrupt master enable flag(I-flag) is automatically cleared and other interrupts are inhibited. When interrupt service is completed by RETI instruction, I-flag is set automatically. If other interrupts are generated during interrupt service, The interrupt having higher priority is accepted when the previous interrupt service routine is completed.

In order to multiple interrupts, I-flag must be cleared by EI instruction within the interrupt routine. Then, The higher priority interrupt is accepted among the interrupts that interrupt request flag is "1".

■ **Interrupt Mode Register (IMOD)**

if IM1,IM0 is selected as "01", the interrupt selected by IP0~IP3 can be accepted and other interrupts are not accepted. Using this register, we can change the interrupt priority order by s/w.

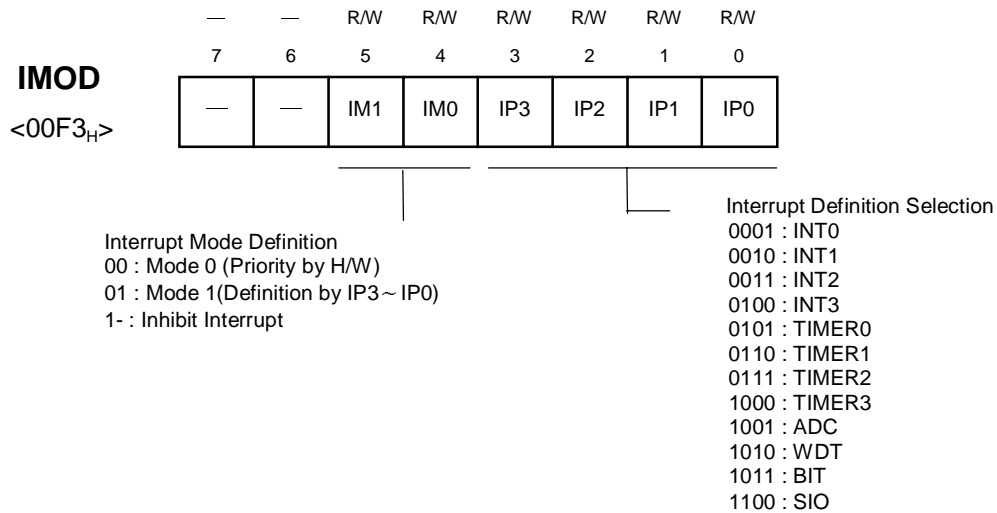

When multiple interrupt is accepted, it is possible to change Interrupt Accept Mode.  
 In case of multiple interrupt at hardware priority accept mode(Mode0)

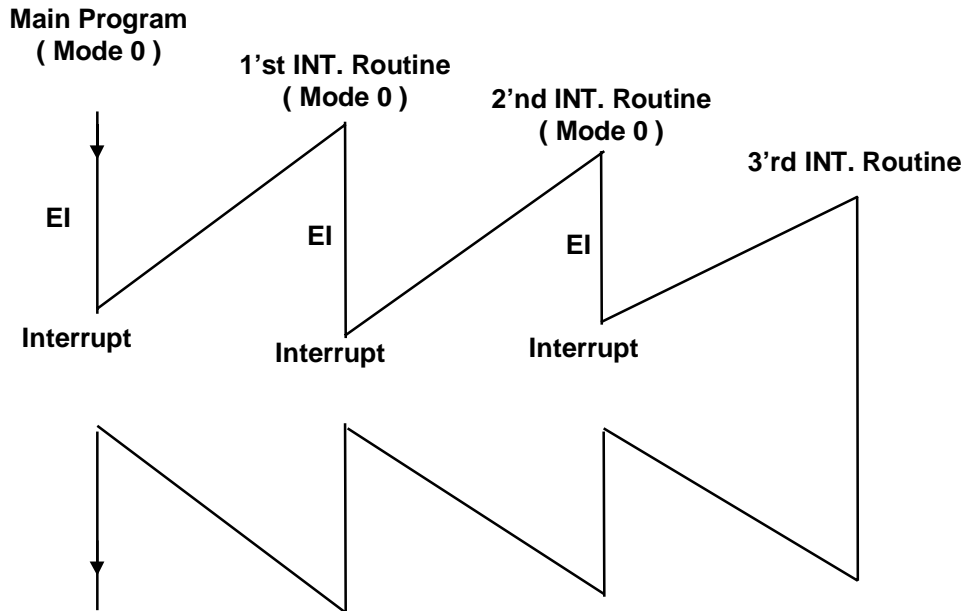

In case of multiple interrupts nest H/W priority accept mode (Mode0) and S/W selection accept mode(Mode1)

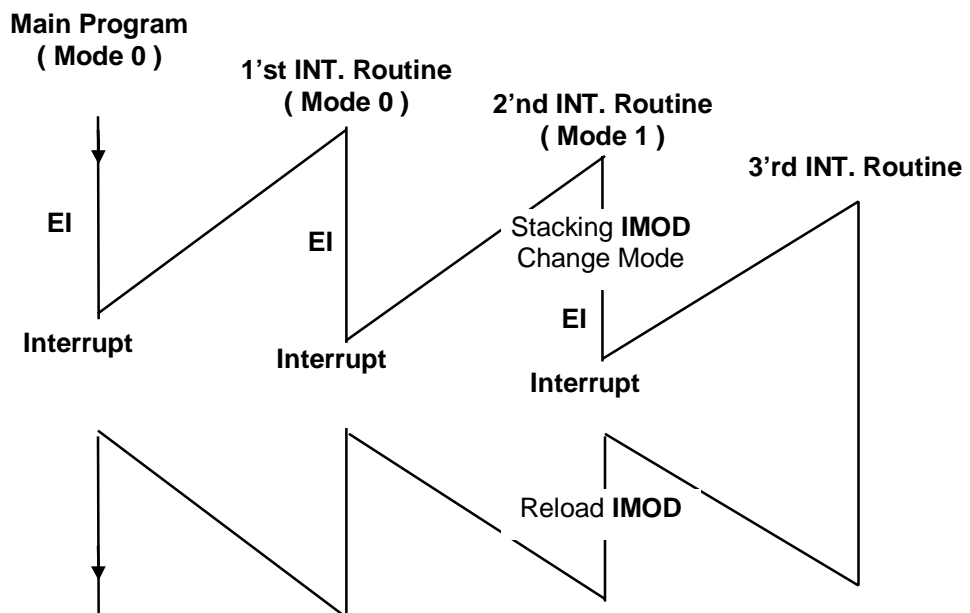



**2.13. STANDBY FUNCTION**

To save the consuming power of device, GMS81508/16 has STOP Mode.

In this mode, the execution of program is stopped. Stop Mode entered by STOP instruction.

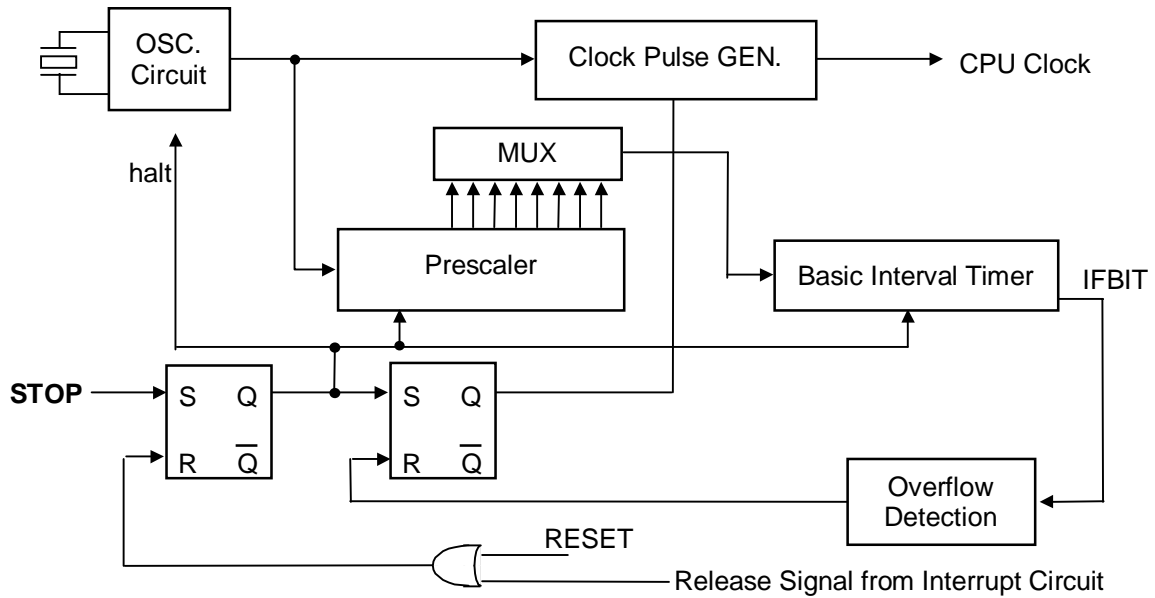

◆ At STOP Mode, Device Operation State.

Peripheral Function	STOP Mode
Oscillator	×
CPU Clock	×
RAM, Register	Retain
I/O Port	Retain
Prescaler	×
Basic Interval Timer	×
Serial I/O	Operation( External Clock Selection)
WDT, Timer, A/DC,PWM, Buzzer Driver	×
Address Bus, Data Bus	Retain
$\overline{Rd}$ , $\overline{Wt}$ , $\overline{R/W}$	Retain
$\overline{HALT}$ , $\overline{BRQ}$ , $\overline{BAK}$	Active
C	"L" level
$\overline{SYNC}$	"H" level

### 2.13.1. STOP Mode

STOP Mode can be entered by STOP instruction during program execution. In STOP mode, oscillator is stopped to make all clocks stop, which leads to the mode requiring much less power consumption. All register and RAM data are preserved.

**Caution) NOP instruction have to be written more than 2 to next lines of STOP instruction.**

### 2.13.2. STOP Mode Release

The release of STOP mode is done by reset input or interrupt. When there is a release signal of STOP mode, the instruction execution is started after stabilization oscillation time set by program. After releasing STOP mode, instruction execution is different by I-Flag(bit 2 of PSW).

If I-Flag = "1" entered Interrupt Service Routine,

If I-Flag = "0" execute program from next instruction of STOP instruction.

#### ◆ STOP Mode Release

Release Factor	Release Method
RESET	By RESET pin=Low level, and Device is initialized.
INT0,INT1 INT2,INT3	In the state of enable flag=1 corresponding to each interrupt at the edge.
Serial I/O	When Serial I/O is executed by external clock, STOP mode is released.

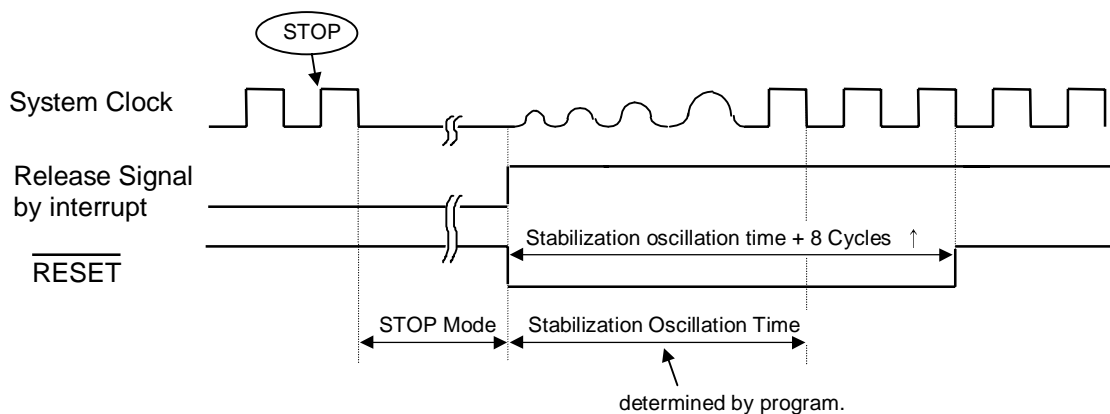

#### ◆ Release Timing of STOP Mode

When release the STOP Mode, to secure oscillation stabilization time, we use Basic Interval Timer. So, before execution STOP instruction, we must select suitable B.I.T. clock for oscillation stabilization time. Otherwise, It is possible to release by only RESET input.

Because STOP mode is released by interrupt, even if both of interrupt enable bit(IE) and interrupt request flag is "1", STOP mode can not be executed.

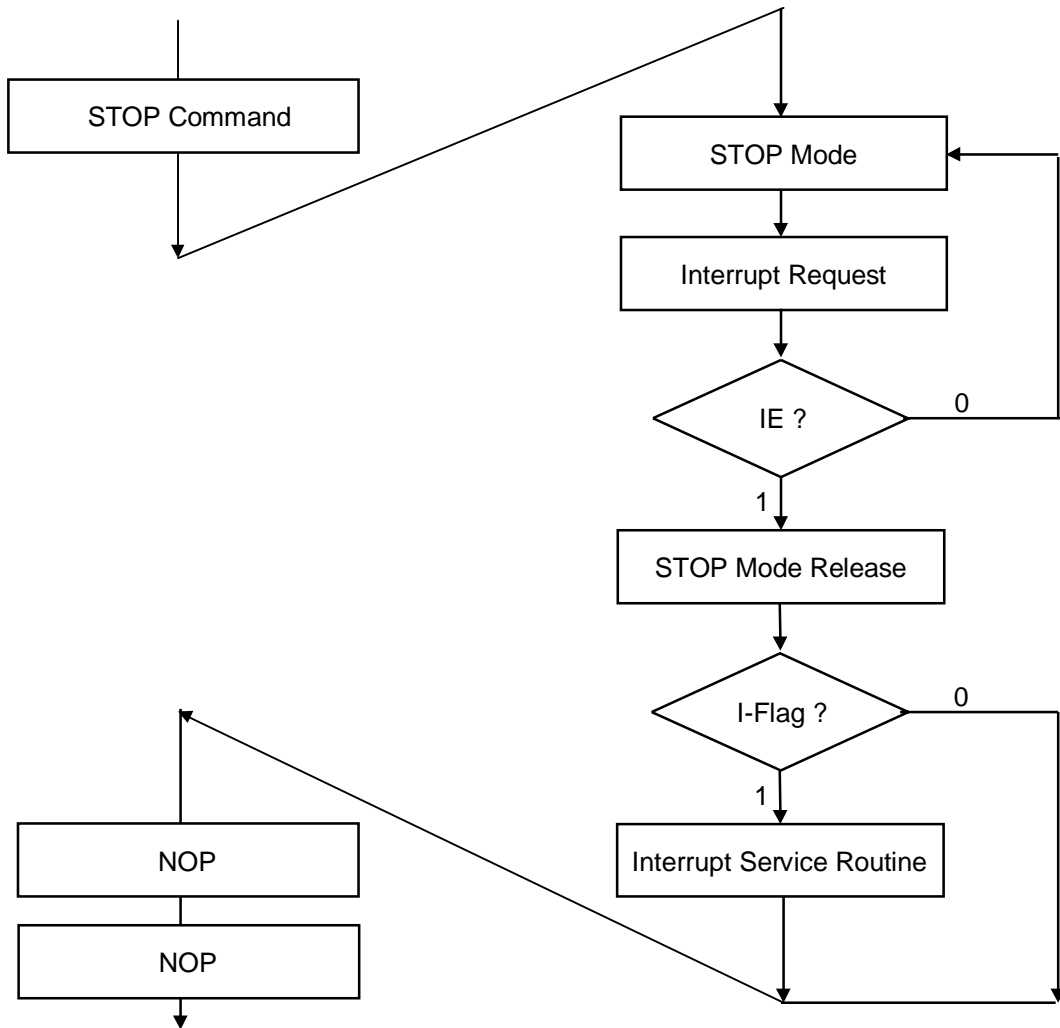

◆ STOP Mode Releasing Flow

## 2.14. RESET FUNCTION

To reset the device, maintain the  $\overline{\text{RESET}} = "L"$  at least 8 machine cycle after power supplying and oscillation stabilization.

$\overline{\text{RESET}}$  terminal is organized as schmitt input.

If initial value is undefined, it is needed initialize by a S/W.

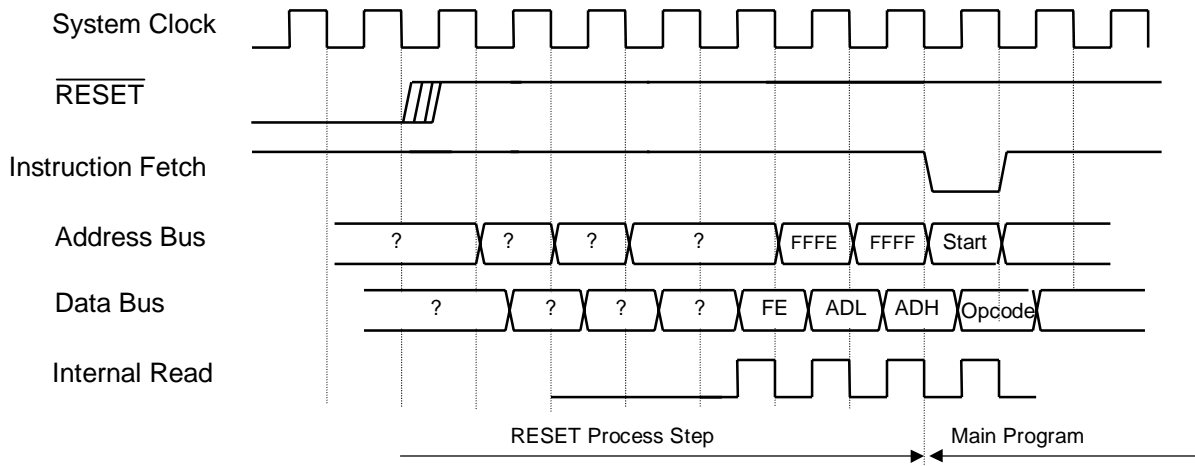

FFFE<sub>H</sub> is vector address and ADL, ADH is start address of main program as vector contents

### ◆ RESET Operation Timing

### 3. I/O PORTS

There are 7-ports(R0~R6) in this device. This ports are double-functional ports and the function can be selected by program.

The direction of ports is determined by Port Direction Register.(1=output, 0=input) The data that is written on the programmed output pin is stored in the port data register and is transferred to the output pin. When data is input to the programmed pin. data is read not from output pin but from port data register. therefore, previously output data can be read correctly regardless or the logical level of the pin due to output loading.

Because the programmed input pin is floating, the value of the pin can be read correctly. When data is written to the programmed input pin, it is written only to the port data register and the pin remains floating.

#### 3.1. R0 PORT

R0 Port is composed of 8-bit programmable I/O pin.

Register Name	Symbol	R/W	Address	Initial Value
R0 I/O Direction Register	R0DD	W	00C1 <sub>H</sub>	0000 0000
R0 PORT Data Register	R0	R/W	00C0 <sub>H</sub>	Not initialized

##### ■ R0 PORT I/O DIRECTION REGISTER

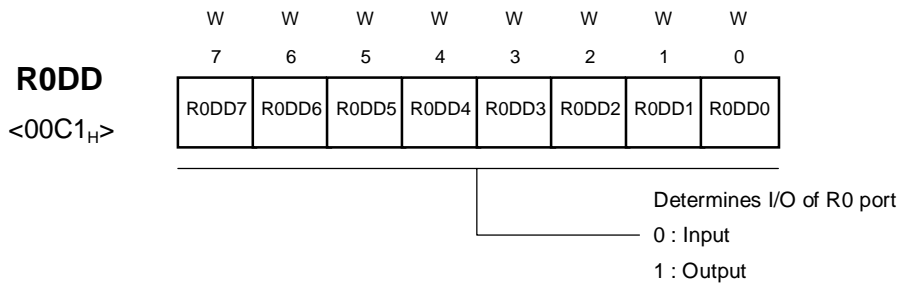

##### ■ R0 PORT DATA REGISTER

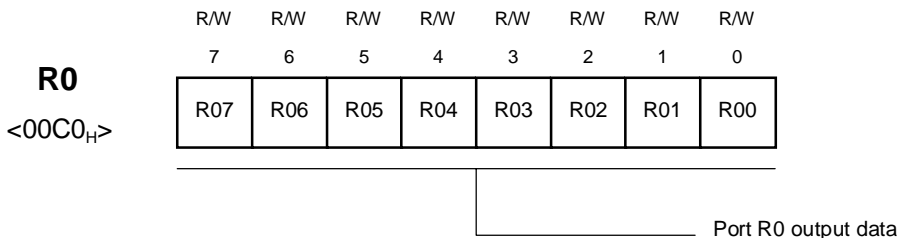

■ Pin Function According to Operation Modes

PIN	Single Chip Mode		Microprocessor Mode	
R00/D0	I/O	Programmable I/O Port	I/O	Data I/O Port from/to External Memory for CPU.
R01/D1	I/O		I/O	
R02/D2	I/O		I/O	
R03/D3	I/O		I/O	
R04/D4	I/O		I/O	
R05/D5	I/O		I/O	
R06/D6	I/O		I/O	
R07/D7	I/O		I/O	

3.2. R1 PORT

R1 Port is composed of 8-bit programmable I/O pin.

Register Name	Symbol	R/W	Address	Initial Value
R0 I/O Direction Register	R1DD	W	00C3 <sub>H</sub>	0000 0000
R0 PORT Data Register	R1	R/W	00C2 <sub>H</sub>	Not initialized

■ R1 PORT I/O DIRECTION REGISTER

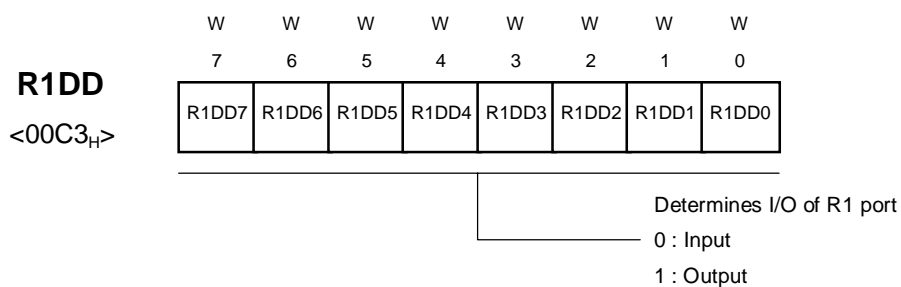

■ R1 PORT DATA REGISTER

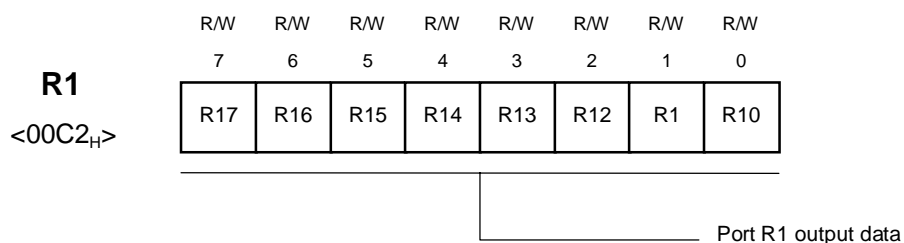

■ Pin Function According to Operation Modes

PIN	Single Chip Mode		Microprocessor Mode	
R10/A0	I/O	Programmable I/O Port	O	low 8bit address of External Memory for CPU.
R11/A1	I/O		O	
R12/A2	I/O		O	
R13/A3	I/O		O	
R14/A4	I/O		O	
R15/A5	I/O		O	
R16/A6	I/O		O	
R17/A7	I/O		O	

### 3.3. R2 PORT

R2 Port is composed of 8-bit programmable I/O pin.

Register Name	Symbol	R/W	Address	Initial Value
R2 I/O Direction Register	R2DD	W	00C5 <sub>H</sub>	0000 0000
R2 PORT Data Register	R2	R/W	00C4 <sub>H</sub>	Not initialized

#### ■ R2 PORT I/O DIRECTION REGISTER

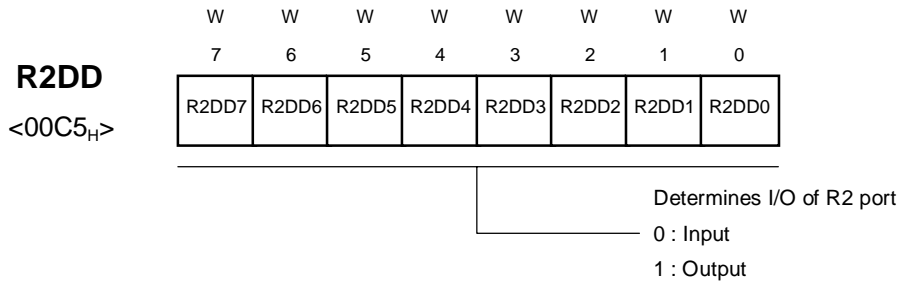

#### ■ R2 PORT DATA REGISTER

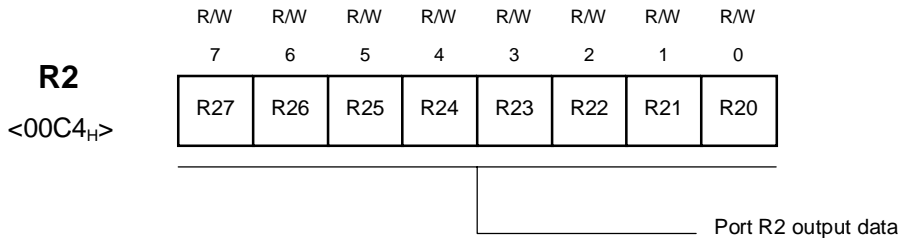

### ■ Pin Function According to Operation Modes

PIN	Single Chip Mode		Microprocessor Mode	
R20/A8	I/O	Programmable I/O Port	O	upper 8bit address of External Memory for CPU.
R21/A9	I/O		O	
R22/A10	I/O		O	
R23/A11	I/O		O	
R24/A12	I/O		O	
R25/A13	I/O		O	
R26/A14	I/O		O	
R27/A15	I/O		O	

### 3.4. R3 PORT

R3 Port is composed of 8-bit programmable I/O pin.

Register Name	Symbol	R/W	Address	Initial Value
R3 I/O Direction Register	R3DD	W	00C7 <sub>H</sub>	0000 0000
R3 PORT Data Register	R3	R/W	00C6 <sub>H</sub>	Not initialized

#### ■ R3 PORT I/O DIRECTION REGISTER

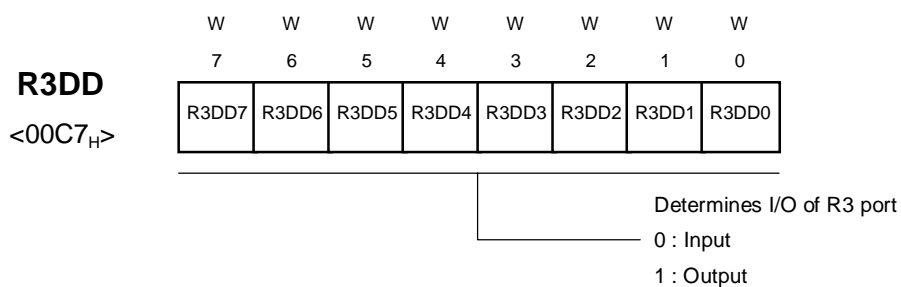

#### ■ R3 PORT DATA REGISTER

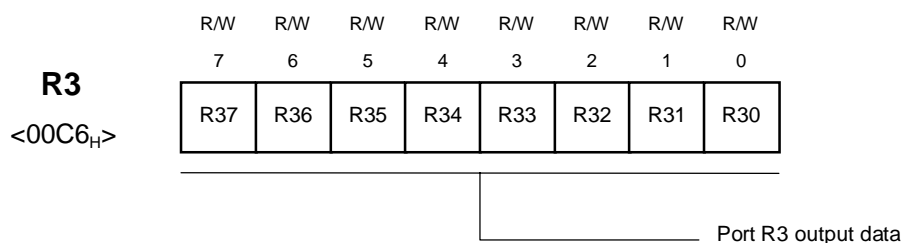



■ Pin Function According to Operation Modes

PIN	Single Chip Mode		Microprocessor Mode	
R30	I/O	Programmable I/O Port	O	$\overline{Rd}$ : external memory read strobe
R31	I/O		O	$\overline{Wt}$ : external memory write strobe
R32	I/O		O	$\overline{R/W}$ :Read/Write cycle output pin of CPU
R33	I/O		O	C : timing signal output pin
R34	I/O		O	$\overline{SYNC}$ : op code fetch output pin of CPU
R35	I/O		O	$\overline{BRK}$ : bus acknowledge output pin of CPU
R36	I/O		I	$\overline{BRQ}$ : bus request input pin of CUP
R37	I/O		I	$\overline{HALT}$ : CPU halt input pin

3.5. R4 PORT

R4 Port is composed of 8bit programmable I/O port and this port are double functional pin.

Register Name	Symbol	R/W	Address	Initial Value
R4 I/O Direction Register	R4DD	W	00C9 <sub>H</sub>	0000 0000
R4 Port Data Register	R4	R/W	00C8 <sub>H</sub>	Not initialized
Port R4 Mode Register	PMR4	W	00D0 <sub>H</sub>	0000 0000
Interrupt Edge Select Register	IEDS	R/W	00F8 <sub>H</sub>	0000 0000

■ R4 PORT I/O DIRECTION REGISTER

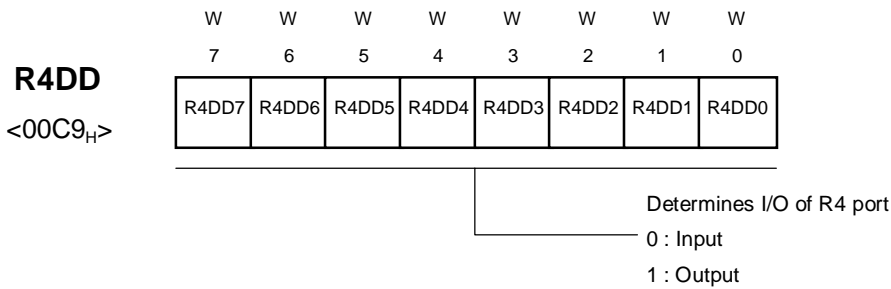

■ R4 PORT DATA REGISTER

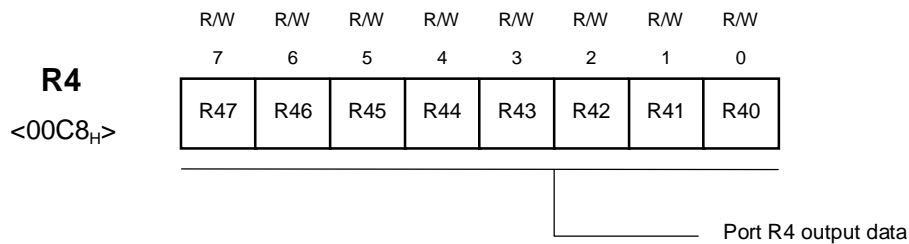

### ■ PORT R4 MODE REGISTER

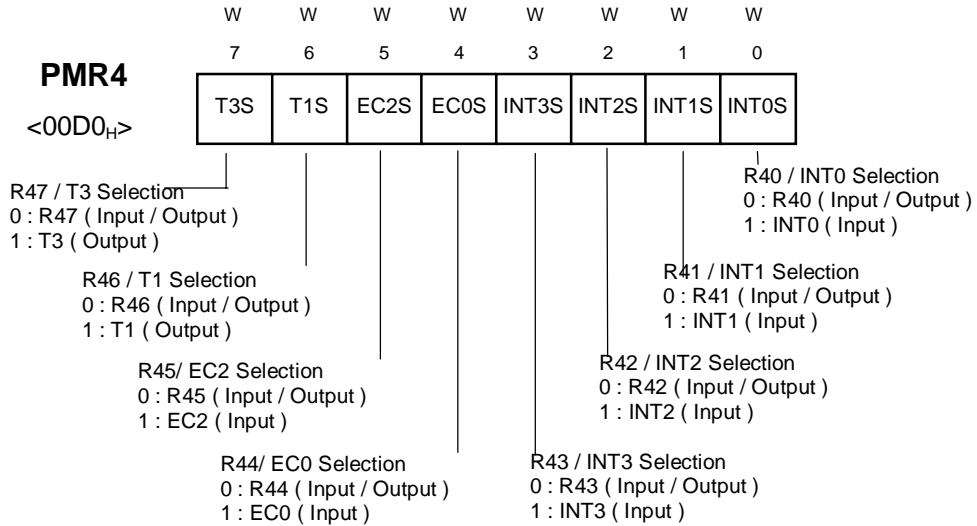

### ■ INTERRUPT EDGE SELECTION REGISTER

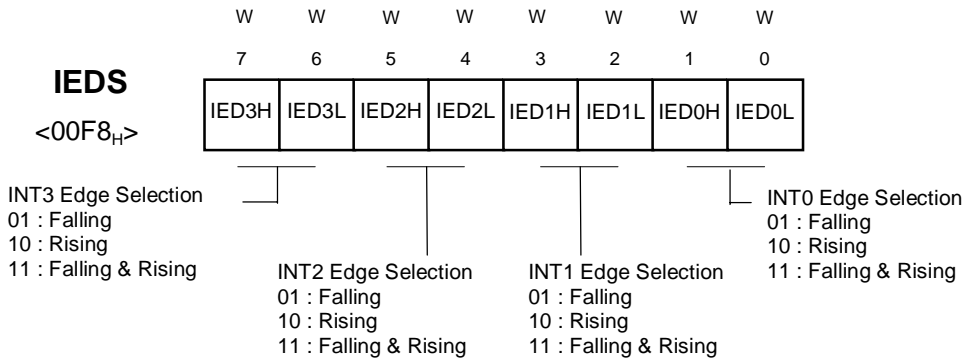

## 3.6. R5 PORT

R5 Port is composed of 8-bit programmable I/O port. R54,R55 is double functional pin.

Register Name	Symbol	R/W	Address	Initial Value
R5 I/O Direction Register	R5DD	W	00CB <sub>H</sub>	0000 0000
R5 Port Data Register	R5	R/W	00CA <sub>H</sub>	Not initialized
R5 Port Mode Register	PMR5	W	00D1 <sub>H</sub>	--00 ----

■ R5 PORT I/O DIRECTION REGISTER

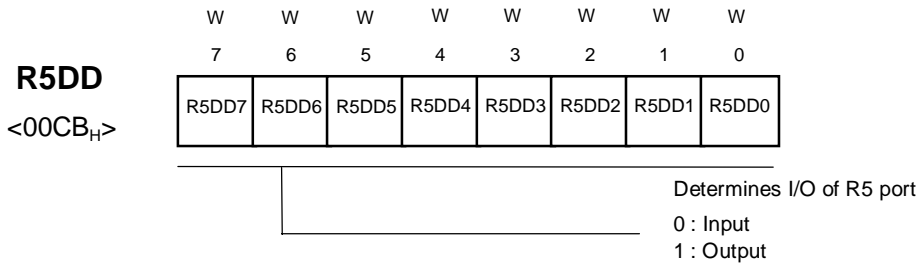

■ R5 PORT DATA REGISTER

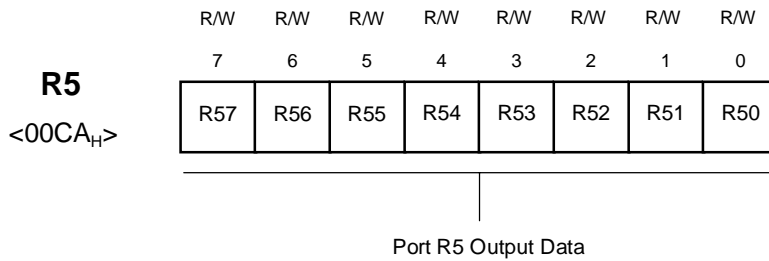

■ PORT R5 MODE REGISTER

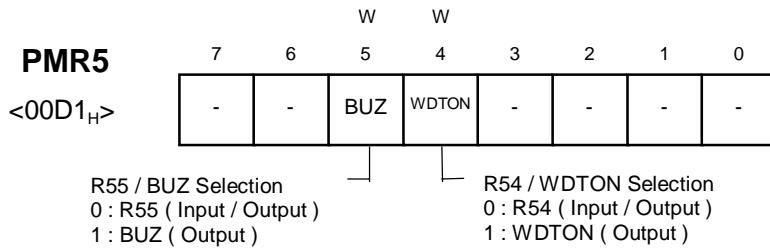

3.7. R6 PORT

R6 Port consists of 4-bit Programmable I/O ports and 4-bit input only ports and this port can be used as a analog input port for A/D conversion by program.

Register Name	Symbol	R/W	Address	Initial Value
R6 I/O Direction Register	R6DD	W	00CD <sub>H</sub>	0000 ----
R6 Port Data Register	R6	R/W	00CC <sub>H</sub>	Not initialized
A/D Converter Mode Register	ADCM	W	00E8 <sub>H</sub>	--00 0001

### ■ R6 PORT I/O DIRECTION REGISTER

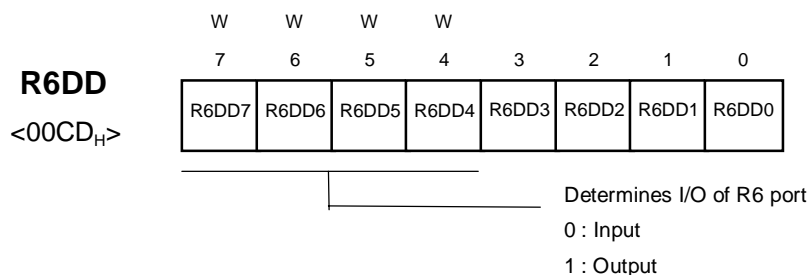

### ■ R6 PORT DATA REGISTER

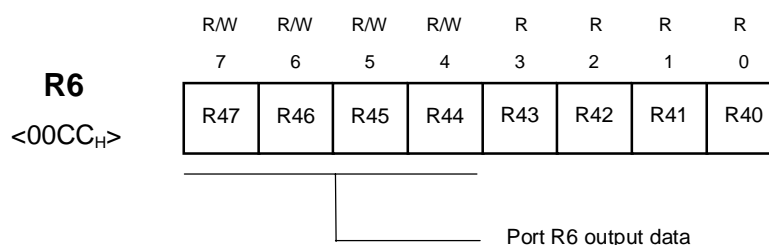

*On the initial RESET, R60 can't be used digital input port, because this port is selected as an analog input port by ADCM register. To use this port as a digital I/O port, change the value of lower 4 bits of ADCM(address 0E8H). On the other hand, R6 port, all eight pins can not be used as digital I/O port simultaneously. At least one pin is used as an analog input.*

### ■ UNUSED PORTS

All unused ports should be set properly that current flow through port doesn't exist.

First consider the setting the port as an input mode. Be sure that there is no current flow after considering its relationship with external circuit. In input mode, the pin impedance viewing from external MCU is very high that the current doesn't flow.

But input voltage level should be  $V_{SS}$  or  $V_{DD}$ . Be careful that if unspecified voltage, i.e. if unfirmed level voltage is applied to input pin, there can be little current ( max. 1mA at 2V) flow.

If it is not appropriate to set as an input mode, then set to output mode considering there is no current flow. Setting to High or Low is decided considering its relationship with external circuit. For example, if there is external pull-up resistor then it is set to output mode, i.e. to High, and if there is external pull-down register, it is set to low.

3.8. TERMINAL TYPES

PIN	TERMINAL TYPE
<p><b>Xin</b> <b>Xout</b></p>	
<p><b>RESET</b></p>	
<p><b>MP</b></p>	
<p><b>R00 ~ R07</b></p>	

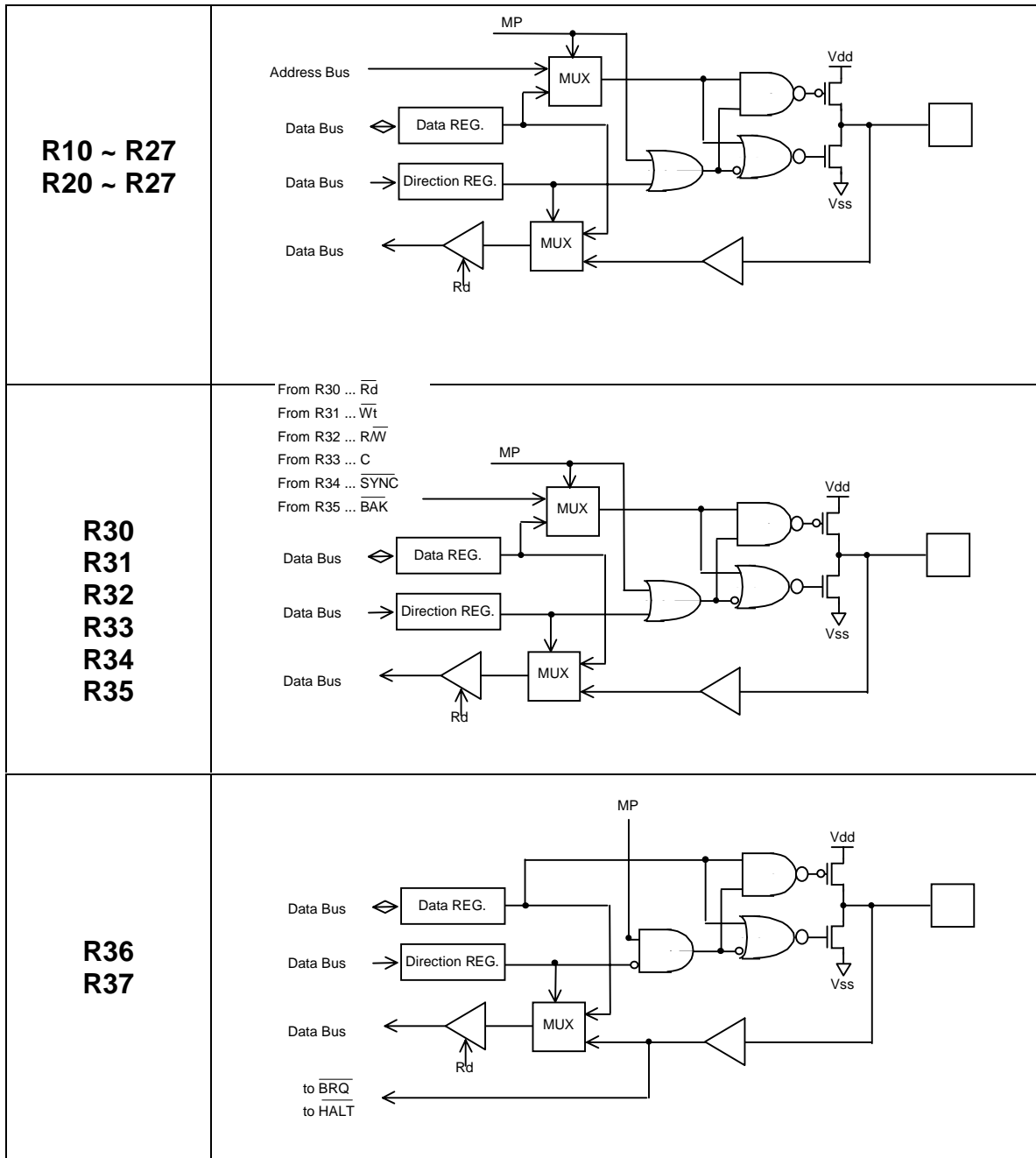

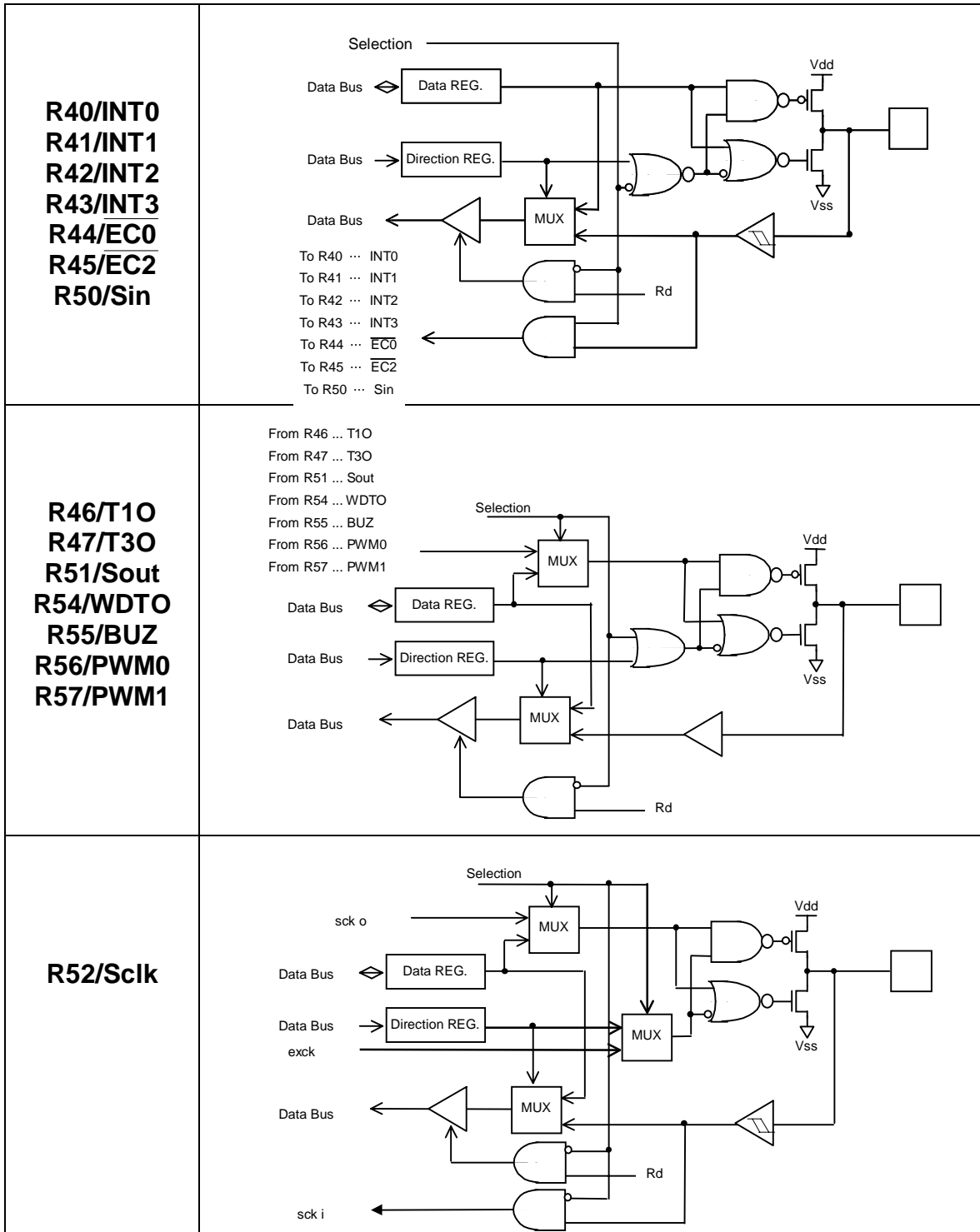

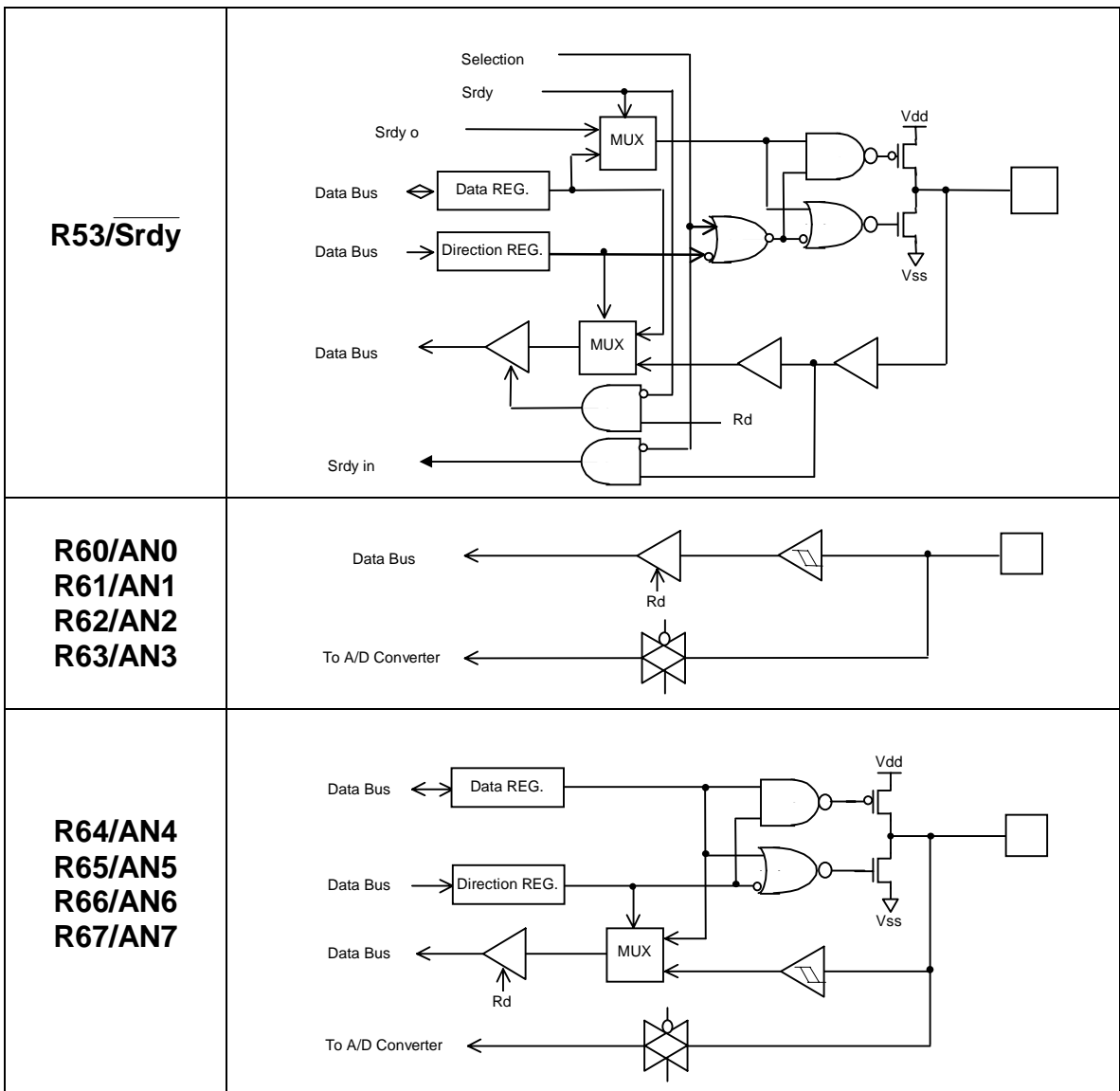



## 4. ELECTRICAL CHARACTERISTICS

### 4.1. ABSOLUTE MAXIMUM RATINGS

Parameter	Symbol	Unit	Ratings
Supply Voltage	Vdd	V	-0.3 ~ 7.0
Input Voltage	Vi	V	-0.3 ~ Vdd+0.3
Storage Temperature	Tstg	°C	-40 ~ 125

### 4.2. RECOMMENDED OPERATING CONDITIONS

Parameter	Symbol	Unit	Specifications		
			Min.	Typ.	Max.
Supply Voltage	Vdd	V	4.5		5.5
Operating Frequency	fXin	MHz	1		8
Operating Temperature	Topr	°C	-20		85

### 4.3. A/D CONVERTER CHARACTERISTICS

( Vdd = 5V ± 10%, Vss = 0V , f (Xin) = 8 MHz )

Parameter	Pin	Symbol	Unit	SPECIFICATION			ETC
				Min.	Typ.	Max.	
Analog Input Range	AN0~AN7	VAIN	V	Vss		Vref	
Accuracy			LSB			± 3	
Conversion Time		Tconv	μs			20	
Analog Power Supply Input Range	AVref	Vref	V			Vdd	

#### 4.4. DC CHARACTERISTICS

( Vdd = 5.0V ± 10%, Vss = 0V, Ta = -20 ~ 85°C, f (Xin) = 8 MHz )

Parameter	Symbol	Pin	Test Condition	Unit	Specifications		
					Min.	Typ.	Max.
"H" Input voltage	Vih	$\overline{\text{RESET}}, \text{R4, R5, R6}$		V	0.8Vdd		Vdd
		R0, R1, R2, R3			0.7Vdd		Vdd
		Xin			0.9Vdd		Vdd
"L" Input voltage	Vil	$\overline{\text{RESET}}, \text{R4, R5, R6}$		V	0		0.12Vdd
		R0, R1, R2, R3			0		0.3Vdd
		Xin			0		0.1Vdd
"H" Input Leakage Current	lih	all input pins	Vi = Vdd	μA	-5		5
"L" Input Leakage Current	lil	all input pins	Vi = Vss	μA	-5		5
"H" output Voltage	Voh	R0, R1, R2, R3, R4, R5	Ioh = -2mA	V	Vdd-1		
"L" output Voltage		R0, R1, R2, R3, R4, R5	Iol = 5mA	V			1.0
Power Current	Operating	Idd	all input = Vss	mA		20	40
	STOP	Istop			μA		20
Hysteresis	VT+ ~ VT-	$\overline{\text{RESET}},$ EC2, EC0, Sin, Sclk, INT0~3		V	0.3		0.8
					0.3		0.8
RAM Data Retention	Vram	Vdd	at clock stop	V	2.0		

4.5. AC CHARACTERISTICS

4.5.1. Input Conditions

( Vdd = 5.0V±10%, Vss = 0V, Ta = -20 ~ 85°C, f (Xin) = 8 MHz )

Parameter	Pin	Symbol	Unit	SPECIFICATION			ETC
				MIN.	TYP.	MAX.	
Operating Frequency	Xin	fcp	MHz	1	-	8	
System Clock		tsys	ns	500	-	250	
Oscillation Stabilization Time	Xin, Xout	tst	ms			20	
External Clock Pulse Width	Xin	tcpw	ns	100			
External Clock Transition Time	Xin	trcp, tfcp	ns			20	
Interrupt Pulse Width	INT0~INT3	tiw	tsys	2			
RESET Input "L" Width	RESET	trst	tsys	8			
Event Counter Input Pulse Width	EC0, EC2	tecw	tsys	2			
Event Counter Transition Time	EC0, EC2	trEC, tfEC	ns			20	

■ Timing Chart

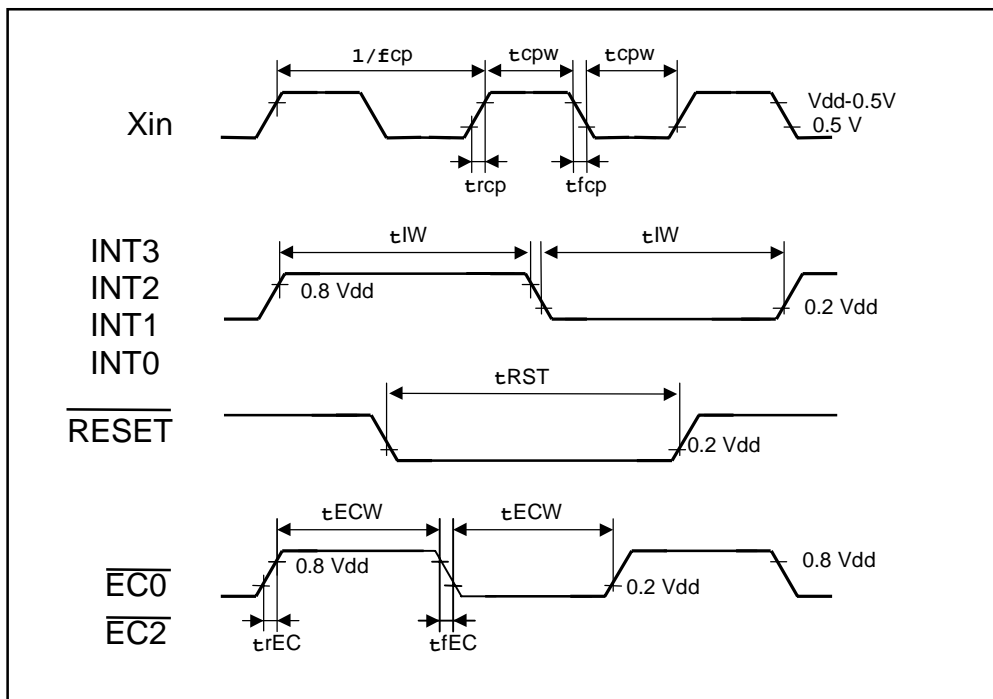

4.5.2. Serial Transfer

( Vdd = 5.0V±10%, Vss = 0 V , Ta = -20 ~ 85°C , f (Xin) = 8 MHz )

Parametet	Pin	Symbol	Unit	SPECIFICATION			etc
				MIN.	TYP.	MAX.	
Serial Input Clock Pulse	Sclk	tscyc	ns	2tsys+200	-	8	
Serial Input Clock Pulse Width	Sclk	tsckw	ns	tsys+70	-	8	
Serial Input Clock Pulse Transition Time	Sclk	tfscck,trscck	ns		-	30	
Sin Input Pulse Transition Time	Sin	tfsin,trsin	ns		-	30	
Sin Input Setup time(Exnternal Sclk)	Sin	tsus	ns	100	-		
Sin Input Setup time(Internal Sclk)	Sin	tsus	ns	200	-		
Sin Input Hold Time	Sin	ths	ns	tsys+70	-		
Serial Output Clock Cycle Time	Sclk	tscyc	ns	4tsys	-	16tsys	
Serial Output Clock Transition Time	Sclk	tsckw	ns	2tsys-30	-		
Serial Output Clock Transition Time	Sclk	tfscck,trscck	ns		-	30	
Serial Output Delay Time	Sout	trec, tfec	ns			100	

■ Serial I/O Timing Chart

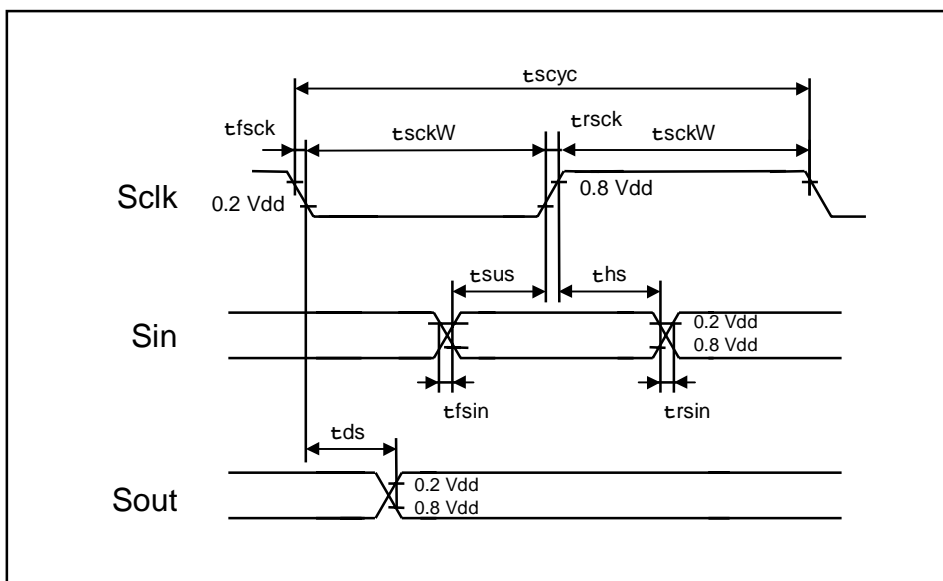

4.5.3. Microprocessor Mode I/O Timing

( Vdd = 5.0V±10%, Vss = 0V, Ta = -20 ~ 85°C, f (Xin) = 8 MHz )

Parameter	Pin	Symbol	Unit	SPECIFICATION			etc
				MIN.	TYP.	MAX.	
Control Clock Output Width	C	tCL	ns	90	-		
Address Output Delay Time	A0 ~ A15	tdCA	ns		-	80	
Data Output Delay Time	D0 ~ D7	tdCD	ns		-	180	
Data Output Hold Time	D0 ~ D7	thw	ns		-	20	
Data Input Setup Time	D0 ~ D7	tsuR	ns	80	-		
Data Input Hold Time	D0 ~ D7	thR	ns	15	-		
Rd Output Delay Time	$\overline{Rd}$	tdRd	tsys		-	90	
Wt Output Delay Time	$\overline{Wt}$	tdWt	tsys		-	130	
R/W Output Delay Time	R/W	tdRW	tsys		-	50	
sync Output Delay Time	$\overline{SYNC}$	tdsync	tsys		-	50	

■ Timing Chart

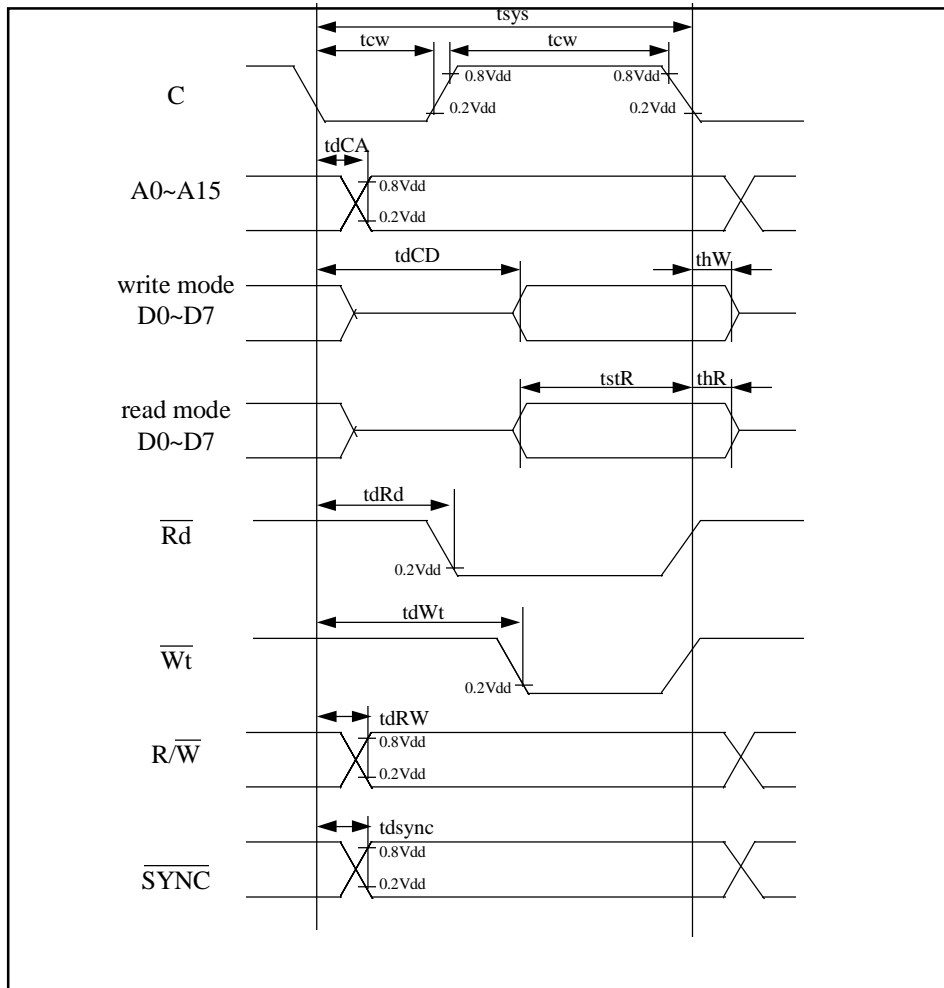

4.5.4. Bus Holding Timing

( Vdd = 5.0V±10%, Vss = 0V , Ta = -20 ~ 85°C , f (Xin) = 8 MHz )

Parameter	Pin	Symbol	Unit	SPECIFICATION			etc
				MIN.	TYP.	MAX.	
BRQ Setup Time	$\overline{\text{BRQ}}$	tSUB	tsys	100	-		
BAK Delay Time	$\overline{\text{BAK}}$	tdBA	tsys		-	50	
BAK Release Delay Time	$\overline{\text{BAK}}$	tdRBA	tsys		-	220	
Bus(Address,Data) Control Release Delay Time	D0 ~ D7 A0 ~ A15 $\overline{\text{Rd}}$ , $\overline{\text{Wt}}$ , $\overline{\text{R/W}}$	tdRA	tsys		-	210	

■ Timing Chart

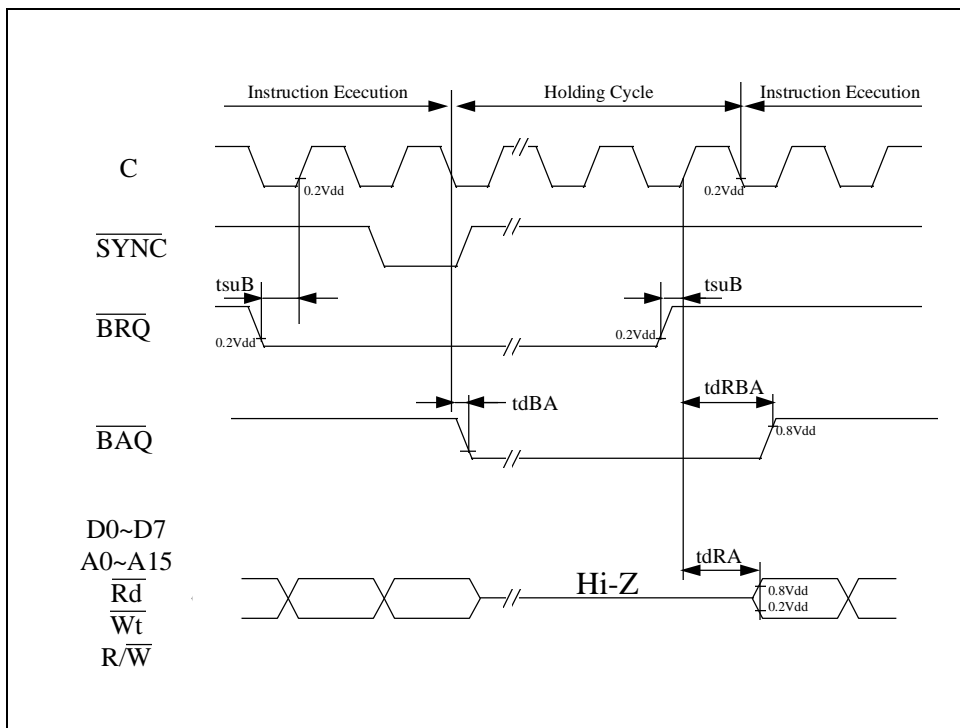

## 5. INSTRUCTION SET

### 1. ARITHMETIC/ LOGIC OPERATION

NO.	MNEMONIC	OP CODE	BYTE NO	CYCLE NO	OPERATION	FLAG NVGBHIZC
1	ADC #imm	04	2	2	Add with carry. $A \leftarrow (A) + (M) + C$	NV--H-ZC
2	ADC dp	05	2	3		
3	ADC dp + X	06	2	4		
4	ADC !abs	07	3	4		
5	ADC !abs + Y	15	3	5		
6	ADC [ dp + X ]	16	2	6		
7	ADC [ dp ] + Y	17	2	6		
8	ADC { X }	14	1	3		
9	AND #imm	84	2	2	Logical AND $A \leftarrow (A) \wedge (M)$	N-----Z-
10	AND dp	85	2	3		
11	AND dp + X	86	2	4		
12	AND !abs	87	3	4		
13	AND !abs + Y	95	3	5		
14	AND [ dp + X ]	96	2	6		
15	AND [ dp ] + Y	97	2	6		
16	AND { X }	94	1	3		
17	ASL A	08	1	2	Arithmetic shift left C    7 6 5 4 3 2 1 0 □ ← ← ← ← ← ← ← ← ← "0"	N-----ZC
18	ASL dp	09	2	4		
19	ASL dp + X	19	2	5		
20	ASL !abs	18	3	5		
21	CMP #imm	44	2	2		
22	CMP dp	45	2	3		
23	CMP dp + X	46	2	4		
24	CMP !abs	47	3	4		
25	CMP !abs + Y	55	3	5		
26	CMP [ dp + X ]	56	2	6		
27	CMP [ dp ] + Y	57	2	6		
28	CMP { X }	54	1	3		
29	CMPX #imm	5E	2	2	Compare X contents with memory contents $(X) - (M)$	N-----ZC
30	CMPX dp	6C	2	3		
31	CMPX !abs	7C	3	4		
32	CMPY #imm	7E	2	2	Compare Y contents with memory contents $(Y) - (M)$	N-----ZC
33	CMPY dp	8C	2	3		
34	CMPY !abs	9C	3	4		
35	COM dp	2C	2	4		
36	DAA	DF	1	3	Decimal adjust for addition	N-----ZC
37	DAS	CF	1	3	Decimal adjust for subtraction	N-----ZC

NO.	MNEMONIC	OP CODE	BYTE NO	CYCLE NO	OPERATION	FLAG NVGBHIZC
38	DEC A	A8	1	2	Decrement	N-----Z-
39	DEC dp	A9	2	4	$M \leftarrow (M) - 1$	N-----Z-
40	DEC dp + X	B9	2	5		N-----Z-
41	DEC !abs	B8	3	5		N-----Z-
42	DEC X	AF	1	2		N-----Z-
43	DEC Y	BE	1	2		N-----Z-
44	DIV	9B	1	12	Divide : YA / XQ: A, R: Y	NV--H-Z-
45	EOR #imm	A4	2	2	Exclusive OR	
46	EOR dp	A5	2	3	$A \leftarrow (A) \oplus (M)$	
47	EOR dp + X	A6	2	4		N-----Z-
48	EOR !abs	A7	3	4		N-----Z-
49	EOR !abs + Y	B5	3	5		N-----Z-
50	EOR [ dp + X ]	B6	2	6		N-----Z-
51	EOR [ dp ] + Y	B7	2	6		N-----Z-
52	EOR { X }	B4	1	3		N-----Z-
53	INC A	88	1	2	Increment	N-----ZC
54	INC dp	89	2	4	$M \leftarrow (M) + 1$	N-----Z-
55	INC dp + X	99	2	5		N-----Z-
56	INC !abs	98	3	5		N-----Z-
57	INC X	8F	1	2		N-----Z-
58	INC Y	9E	1	2		N-----Z-
59	LSR A	48	1	2	Logical shift right	
60	LSR dp	49	2	4		N-----ZC
61	LSR dp + X	59	2	5		N-----ZC
62	LSR !abs	58	3	5		N-----ZC
63	MUL	5B	1	9	Multiply : $YA \leftarrow Y \times A$	N-----Z-
64	OR #imm	64	2	2	Logical OR	
65	OR dp	65	2	3	$A \leftarrow (A) \vee (M)$	
66	OR dp + X	66	2	4		N-----Z-
67	OR !abs	67	3	4		N-----Z-
68	OR !abs + Y	75	3	5		N-----Z-
69	OR [ dp + X ]	76	2	6		N-----Z-
70	OR [ dp ] + Y	77	2	6		N-----Z-
71	OR { X }	74	1	3		N-----Z-
72	ROL A	28	1	2	Rotate left through carry	
73	ROL dp	29	2	4		N-----ZC
74	ROL dp + X	39	2	5		N-----ZC
75	ROL !abs	38	3	5		N-----ZC
76	ROR A	68	1	2	Rotate right through carry	
77	ROR dp	69	2	4		N-----ZC
78	ROR dp + X	79	2	5		N-----ZC
79	ROR !abs	78	3	5		N-----ZC



NO.	MNEMONIC	OP CODE	BYTE NO	CYCLE NO	OPERATION	FLAG NVGBHIZC
80	SBC #imm	24	2	2	Subtract with carry $A \leftarrow (A) - (M) - \overline{(C)}$	NV--HZC
81	SBC dp	25	2	3		
82	SBC dp + X	26	2	4		
83	SBC !abs	27	3	4		
84	SBC !abs + Y	35	3	5		
85	SBC [ dp + X ]	36	2	6		
86	SBC [ dp ] + Y	37	2	6		
87	SBC { X }	34	1	3		
88	TST dp	4C	2	3	Test memory contents for negative or zero ( dp ) - 00 <sub>H</sub>	N-----Z-
89	XCN	CE	1	5	Exchange nibbles within the accumulator $A_7-A_4 \leftrightarrow A_3-A_0$	N-----Z-

## 2. REGISTER / MEMORY OPERATION

NO.	MNEMONIC	OP CODE	BYTE NO	CYCLE NO	OPERATION	FLAG NVGBHIZC
1	LDA #imm	C4	2	2	Load accumulator $A \leftarrow (M)$	N-----Z-
2	LDA dp	C5	2	3		
3	LDA dp + X	C6	2	4		
4	LDA !abs	C7	3	4		
5	LDA !abs + Y	D5	3	5		
6	LDA [ dp + X ]	D6	2	6		
7	LDA [ dp ] + Y	D7	2	6		
8	LDA { X }	D4	1	3		
9	LDA { X }+	DB	1	4	X- register auto-increment : $A \leftarrow (M), X \leftarrow X + 1$	
10	LDM dp,#imm	E4	3	5	Load memory with immediate data : $(M) \leftarrow imm$	-----
11	LDX #imm	1E	2	2	Load X-register $X \leftarrow (M)$	N-----Z-
12	LDX dp	CC	2	3		
13	LDX dp + Y	CD	2	4		
14	LDX !abs	DC	3	4		
15	LDY #imm	3E	2	2	Load Y-register $Y \leftarrow (M)$	N-----Z-
16	LDY dp	C9	2	3		
17	LDY dp + X	D9	2	4		
18	LDY !abs	D8	3	4		
19	STA dp	E5	2	3	Store accumulator contents in memoy $(M) \leftarrow A$	-----
20	STA dp + X	E6	2	4		
21	STA !abs	E7	3	4		
22	STA !abs + Y	F5	3	5		
23	STA [ dp + X ]	F6	2	6		
24	STA [ dp ] + Y	F7	2	6		
25	STA { X }	F4	1	3		
26	STA { X }+	FB	1	4		

		OP	BYTE	CYCLE		FLAG
--	--	----	------	-------	--	------

NO.	MNEMONIC	CODE	NO	NO	OPERATION	NVGBHIZC
27	STX dp	EC	2	4	Store X-register contents in memoy	
28	STX dp + Y	ED	2	5	( M ) ← X	-----
29	STX !abs	FC	3	5		
30	STY dp	E9	2	4	Store Y-register contents in memoy	
31	STY dp + X	F9	2	5	( M ) ← Y	-----
32	STY !abs	F8	3	5		
33	TAX	E8	1	2	Transfer accumulator contents to X-register : X ← A	N-----Z-
34	TAY	9F	1	2	Transfer accumulator contents to Y-register : Y ← A	N-----Z-
35	TSPX	AE	1	2	Transfer stack-pointer contents to X-register : X ← sp	N-----Z-
36	TXA	C8	1	2	Transfer X-register contents to accumulator: A ← X	N-----Z-
37	TXSP	8E	1	2	Transfer X-register contents to stack-pointer: sp ← X	N-----Z-
38	TYA	BF	1	2	Transfer Y-register contents to accumulator: A ← Y	N-----Z-
39	XAX	EE	1	4	Exchange X-register contents with accumulator :X↔ A	-----
40	XAY	DE	1	4	Exchange Y-register contents with accumulator :Y↔ A	-----
41	XMA dp	BC	2	5	Exchange memory contents with accumulator	
42	XMA dp+X	AD	2	6	( M ) ↔ A	N-----Z-
43	XMA {X}	BB	1	5		
44	XYX	FE	1	4	Exchange X-register contents with Y-register : X↔ Y	-----

### 3. 16-BIT OPERATION

NO.	MNEMONIC	OP CODE	BYTE NO	CYCLE NO	OPERATION	FLAG NVGBHIZC
1	ADDW dp	1D	2	5	16-Bits add without carry YA ← ( YA ) + ( dp + 1 ) ( dp )	NV--H-ZC
2	CMPW dp	5D	2	4	Compare YA contents with memory pair contents : (YA) - (dp+1)(dp)	N-----ZC
3	DECW dp	BD	2	6	Decrement memory pair ( dp+1 )( dp ) ← ( dp+1 ) ( dp ) - 1	N-----Z-
4	INCW dp	9D	2	6	Increment memory pair ( dp+1 ) ( dp ) ← ( dp+1 ) ( dp ) + 1	N-----Z-
5	LDYA dp	7D	2	5	Load YA YA ← ( dp + 1 ) ( dp )	N-----Z-
6	STYA dp	DD	2	5	Store YA ( dp + 1 ) ( dp ) ← YA	-----
7	SUBW dp	3D	2	5	16-Bits substract without carry YA ← ( YA ) - ( dp + 1 ) ( dp )	NV--H-ZC

4. BIT MANIPULATION

NO.	MNEMONIC	OP CODE	BYTE NO	CYCLE NO	OPERATION	FLAG NVGBHIZC
1	AND1 M.bit	8B	3	4	Bit AND C-flag : $C \leftarrow (C) \wedge (M.bit)$	-----C
2	AND1B M.bit	8B	3	4	Bit AND C-flag and NOT : $C \leftarrow (C) \wedge \overline{(M.bit)}$	-----C
3	BIT dp	0C	2	4	Bit test A with memory :	MM----Z-
4	BIT !abs	1C	3	5	$Z \leftarrow (A) \wedge (M), N \leftarrow (M_7), V \leftarrow (M_6)$	
5	CLR1 dp.bit	y1	2	4	Clear bit : $(M.bit) \leftarrow "0"$	-----
6	CLRA1 A.bit	2B	2	2	Clear A bit : $(A.bit) \leftarrow "0"$	-----
7	CLRC	20	1	2	Clear C-flag : $C \leftarrow "0"$	-----0
8	CLRG	40	1	2	Clear G-flag : $G \leftarrow "0"$	--0-----
9	CLRv	80	1	2	Clear V-flag : $V \leftarrow "0"$	-0--0---
10	EOR1 M.bit	AB	3	5	Bit exclusive-OR C-flag : $C \leftarrow (C) \oplus (M.bit)$	-----C
11	EOR1B M.bit	AB	3	5	Bit exclusive-OR C-flag and NOT : $C \leftarrow (C) \oplus \overline{(M.bit)}$	-----C
12	LDC M.bit	CB	3	4	Load C-flag : $C \leftarrow (M.bit)$	-----C
13	LDCB M.bit	CB	3	4	Load C-flag with NOT : $C \leftarrow \overline{(M.bit)}$	-----C
14	NOT1 M.bit	4B	3	5	Bit complement : $(M.bit) \leftarrow \overline{(M.bit)}$	-----
15	OR1 M.bit	6B	3	5	Bit OR C-flag : $C \leftarrow (C) \vee (M.bit)$	-----C
16	OR1B M.bit	6B	3	5	Bit OR C-flag and NOT : $C \leftarrow (C) \vee \overline{(M.bit)}$	-----C
17	SET1 dp.bit	x1	2	4	Set bit : $(M.bit) \leftarrow "1"$	-----
18	SETA1 A.bit	0B	2	2	Set A bit : $(A.bit) \leftarrow "1"$	-----
19	SETC	A0	1	2	Set C-flag : $C \leftarrow "1"$	-----1
20	SETG	C0	1	2	Set G-flag : $G \leftarrow "1"$	--1-----
21	STC M.bit	EB	3	6	Store C-flag : $(M.bit) \leftarrow C$	-----
22	TCLR1 !abs	5C	3	6	Test and clear bits with A : $A \leftarrow (M), (M) \leftarrow (M) \wedge \overline{(A)}$	N-----Z-
23	TSET1 !abs	3C	3	6	Test and set bits with A : $A \leftarrow (M), (M) \leftarrow (M) \vee (A)$	N-----Z-

5. BRANCH / JUMP OPERATION

NO.	MNEMONIC	OP CODE	BYTE NO	CYCLE NO	OPERATION	FLAG NVGBHIZC
1	BBC A.bit,rel	y2	2	4/6	Branch if bit clear :	-----
2	BBC dp.bit,rel	y3	3	5/7	if $(bit) = 0$ , then $pc \leftarrow (pc) + rel$	
3	BBS A.bit,rel	x2	2	4/6	Branch if bit set :	-----
4	BBS dp.bit,rel	x3	3	5/7	if $(bit) = 1$ , then $pc \leftarrow (pc) + rel$	
5	BCC rel	50	2	2/4	Branch if carry bit clear if $(C) = 0$ , then $pc \leftarrow (pc) + rel$	-----
6	BCS rel	D0	2	2/4	Branch if carry bit set if $(C) = 1$ , then $pc \leftarrow (pc) + rel$	-----
7	BEQ rel	D0	2	2/4	Branch if equal if $(Z) = 1$ , then $pc \leftarrow (pc) + rel$	-----

NO.	MNEMONIC	OP CODE	BYTE NO	CYCLE NO	OPERATION	FLAG NVGBHIZC
8	BMI rel	90	2	2/4	Branch if minus if (N) = 1, then $pc \leftarrow (pc) + rel$	-----
9	BNE rel	70	2	2/4	Branch if not equal if (Z) = 0, then	-----
10	BPL rel	10	2	2/4	Branch if minus if (N) = 0, then $pc \leftarrow (pc) + rel$	-----
11	BRA rel	2F	2	4	Branch always $pc \leftarrow (pc) + rel$	-----
12	BVC rel	30	2	2/4	Branch if overflow bit clear if (V) = 0, then $pc \leftarrow (pc) + rel$	-----
13	BVS rel	B0	2	2/4	Branch if overflow bit set if (V) = 1, then $pc \leftarrow (pc) + rel$	-----
14	CALL !abs	3B	3	8	Subroutine call	
15	CALL [dp]	5F	2	8	$M(sp) \leftarrow (pc_H), sp \leftarrow sp - 1, M(sp) \leftarrow (pc_L), sp \leftarrow sp - 1,$ if !abs, $pc \leftarrow abs$ ; if [dp], $pc_L \leftarrow (dp), pc_H \leftarrow (dp+1)$ .	-----
16	CBNE dp,rel	FD	3	5/7	Compare and branch if not equal :	-----
17	CBNE dp+X,rel	8D	3	6/8	if (A) $\neq$ (M), then $pc \leftarrow (pc) + rel$ .	
18	DBNE dp,rel	AC	3	5/7	Decrement and branch if not equal :	-----
19	DBNE Y,rel	7B	2	4/6	if (M) $\neq$ 0, then $pc \leftarrow (pc) + rel$ .	
20	JMP !abs	1B	3	3	Unconditional jump	
21	JMP [!abs]	1F	3	5	$pc \leftarrow$ jump address	-----
22	JMP [dp]	3F	2	4		
23	PCALL upage	4F	2	6	U-page call $M(sp) \leftarrow (pc_H), sp \leftarrow sp - 1, M(sp) \leftarrow (pc_L),$ $sp \leftarrow sp - 1, pc_L \leftarrow (upage), pc_H \leftarrow "0FF_H"$ .	-----
24	TCALL n	nA	1	8	Table call : $(sp) \leftarrow (pc_H), sp \leftarrow sp - 1,$ $M(sp) \leftarrow (pc_L), sp \leftarrow sp - 1,$ $pc_L \leftarrow (Table\ vector\ L), pc_H \leftarrow (Table\ vector\ H)$	-----

**6. CONTROL OPERATION & etc.**

NO.	MNEMONIC	OP CODE	BYTE NO	CYCLE NO	OPERATION	FLAG NVGBHIZC
1	BRK	0F	1	8	Software interrupt : $B \leftarrow "1"$ , $M(sp) \leftarrow (pc_H)$ , $sp \leftarrow sp - 1$ , $M(s) \leftarrow (pc_L)$ , $sp \leftarrow sp - 1$ , $M(sp) \leftarrow (PSW)$ , $sp \leftarrow sp - 1$ , $pc_L \leftarrow (OFFDE_H)$ , $pc_H \leftarrow (OFFDF_H)$ .	---1-0--
2	DI	60	1	3	Disable interrupts : $I \leftarrow "0"$	-----0--
3	EI	E0	1	3	Enable interrupts : $I \leftarrow "1"$	-----1--
4	NOP	FF	1	2	No operation	-----
5	POP A	0D	1	4	$sp \leftarrow sp + 1$ , $A \leftarrow M(sp)$	( restored )
6	POP X	2D	1	4	$sp \leftarrow sp + 1$ , $X \leftarrow M(sp)$	
7	POP Y	4D	1	4	$sp \leftarrow sp + 1$ , $Y \leftarrow M(sp)$	
8	POP PSW	6D	1	4	$sp \leftarrow sp + 1$ , $PSW \leftarrow M(sp)$	
9	PUSH A	0E	1	4	$M(sp) \leftarrow A$ , $sp \leftarrow sp - 1$	-----
10	PUSH X	2E	1	4	$M(sp) \leftarrow X$ , $sp \leftarrow sp - 1$	
11	PUSH Y	4E	1	4	$M(sp) \leftarrow Y$ , $sp \leftarrow sp - 1$	
12	PUSH PSW	6E	1	4	$M(sp) \leftarrow PSW$ , $sp \leftarrow sp - 1$	
13	RET	6F	1	5	Return from subroutine $sp \leftarrow sp + 1$ , $pc_L \leftarrow M(sp)$ , $sp \leftarrow sp + 1$ , $pc_H \leftarrow M(sp)$	-----
14	RETI	7F	1	6	Return from interrupt $sp \leftarrow sp + 1$ , $PSW \leftarrow M(sp)$ , $sp \leftarrow sp + 1$ , $pc_L \leftarrow M(sp)$ , $sp \leftarrow sp + 1$ , $pc_H \leftarrow M(sp)$	( restored )
15	STOP	00	1	3	Stop mode ( halt CPU, stop oscillator )	-----

## 6. GMS81516AT (OTP) PROGRAMMING

The GMS81516AT is one-time PROM (OTP) microcontroller with 16K bytes electrically programmable read only memory for the GMS81508/16 system evaluation, first production and fast mass production.

To programming the OTP device, user can have two way. One is using the universal programmer which is support HME microcontrollers, other is using the general EPROM programmer.

### 1. Using the Universal programmer

Third party universal programmer support to program the GMS81516AT microcontrollers and lists are shown as below.

Manufacturer: **Advantech**  
Web site: <http://www.aec.com.tw>  
Programmer: LabTool-48

Manufacturer: **Hi-Lo systems**  
Web site: <http://www.hilosystems.com.tw>  
Programmer: ALL-11, GANG-08

Socket adapters are supported by third party programmer manufacturer.

### 2. Using the general EPROM(27C256) programmer

The programming algorithm is similar with the standard EPROM 27C256. It gives some convenience that user can use standard EPROM programmer. **Make sure that 1ms programming pulse must be used, it generally called "Intelligent Mode"**. Do not use 100us programming pulse mode, "Quick Pulse Mode".

When user use general EPROM programmer, socket adapter is essentially required. It convert pin to fit the pin of general 27C256 EPROM.

Three type socket adapters are provided according to package variation as below table.

Socket Adapter	Package Type
OA815A-64SD	64 pin SDIP
OA815A-64QF-10	64 pin LQFP (10 x 10)
OA815A-64QF	64 pin QFP (14 x 20)

With these socket adapters, the GMS81516AT can easily be programmed and verified using Intel 27C256 EPROM mode on general-purpose PROM programmer.

In assembler and file type, two files are generated after compiling. One is "\*.HEX", another is "\*.OTP". The "\*.HEX" file is used for emulation in circuit emulator (CHOICE-Dr™ or CHOICE-Jr™) and "\*.OTP" file is used for programming to the OTP device.

### Programming Procedure

1. Select the EPROM device and manufacturer on EPROM programmer (Intel 27C256).
  2. Select the programming algorithm as an Intelligent mode (apply 1ms writing pulse), not a Quick pulse mode.
  3. Load the file (\*.OTP) to the programmer.
  4. Set the programming address range as below table.
- | Address              | Set Value |
|----------------------|-----------|
| Buffer start address | 4000H     |
| Buffer end address   | 7FFFH     |
| Device start address | 4000H     |
5. Mount the socket adapter with the GMS81516AT on the PROM programmer.
  6. Start the PROM programmer to programming/verifying.

**GMS81516AT PROGRAMMING  
MANUAL**

**DEVICE OVERVIEW**

The GMS81516AT is a high-performance CMOS 8-bit microcontroller with 16K bytes of EPROM. The device is one of GMS800 family. The HME GMS81516AT is a powerful microcontroller which provides a highly flexible and cost effective solution to many embedded control applications. The GMS81516AT provides the following standard features: 16K bytes of EPROM, 448 bytes of RAM, 56 I/O lines, 16-bit or 8-bit timer/counter, a precision analog to digital converter, PWM, on-chip oscillator and clock circuitry.

**PIN CONFIGURATION**

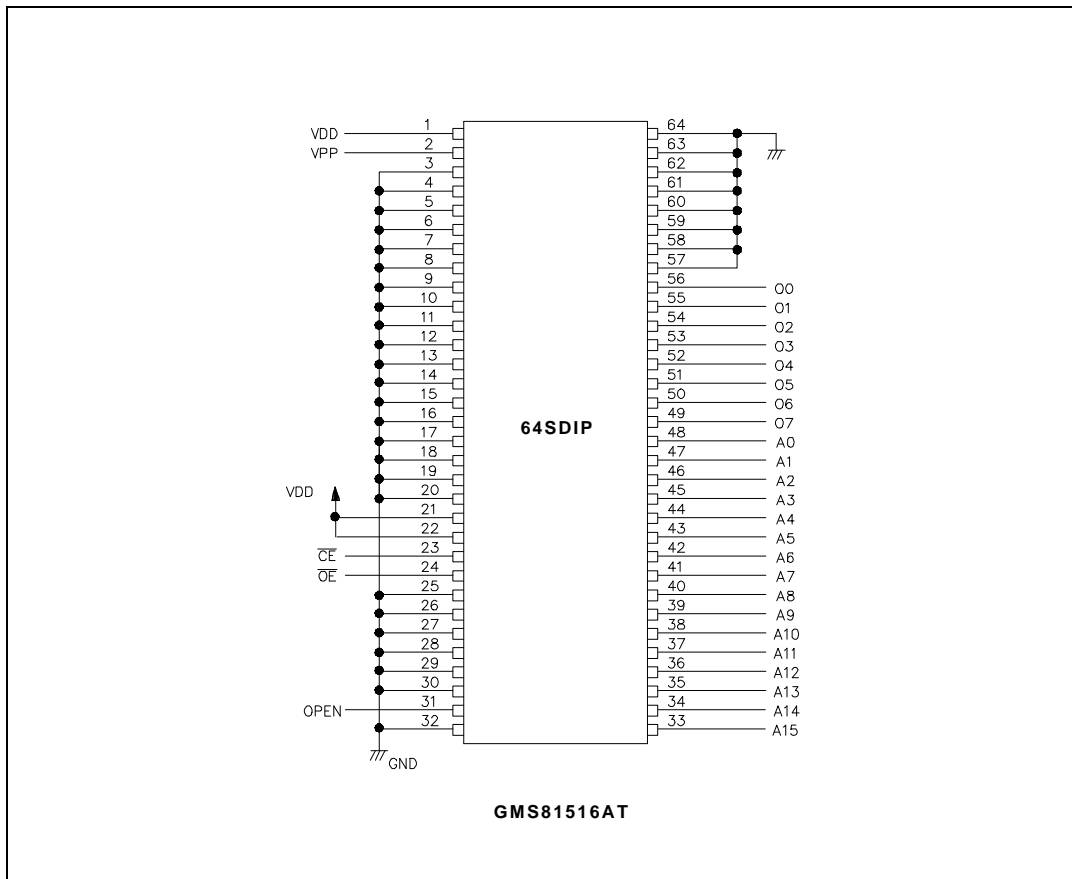



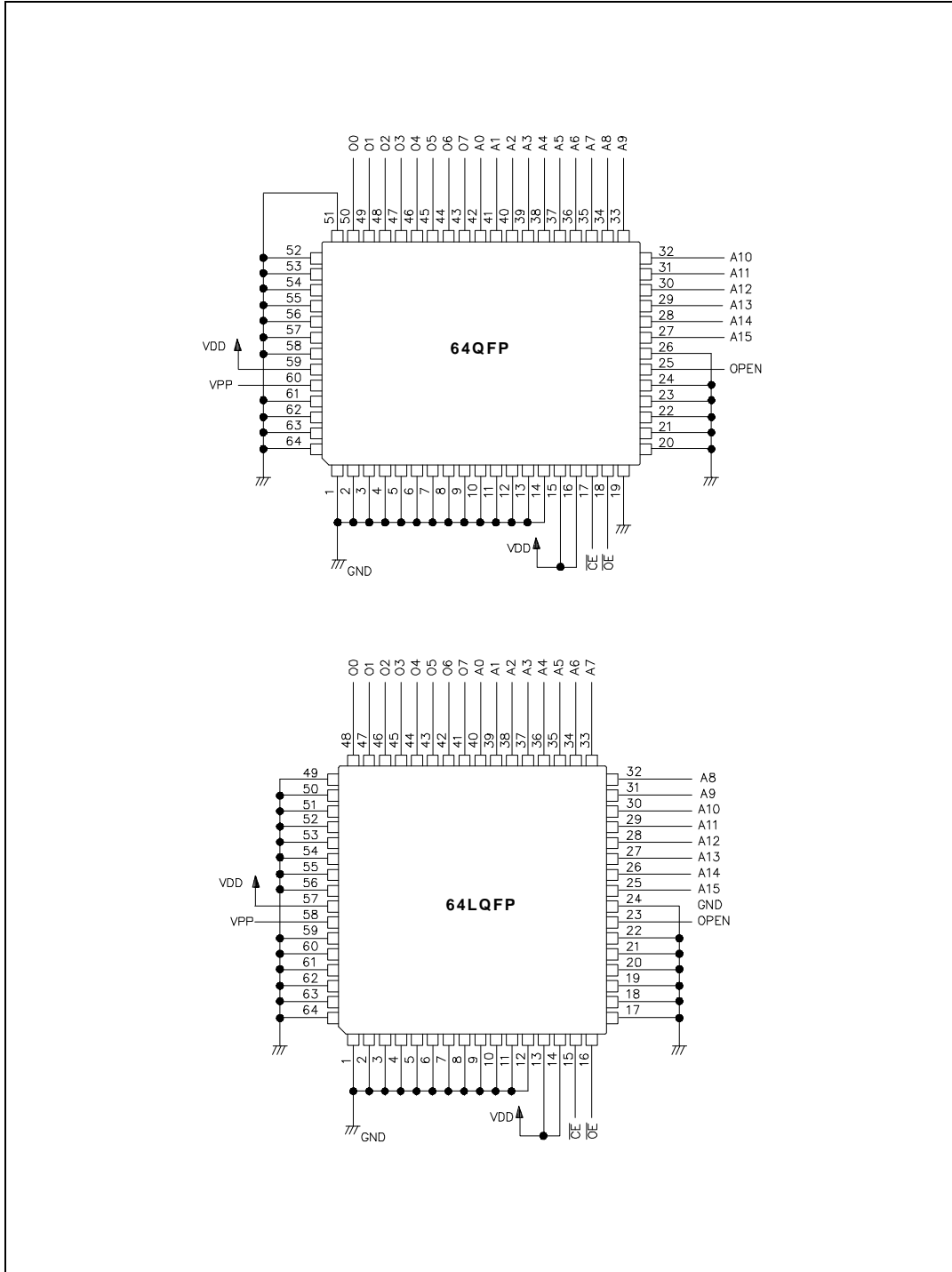

## 64SDIP Package for GMS81516AT

Pin No.	MCU Mode	OTP Mode	Pin No.	MCU Mode	OTP Mode
1	V <sub>DD</sub> -	V <sub>DD</sub> -	33	R27 I/O	A15 I
2	MP I	V <sub>PP</sub> -	34	R26 I/O	A14 I
3	AVSS I	(1) I	35	R25 I/O	A13 I
4	AVREF I	(1) I	36	R24 I/O	A12 I
5	R67/AN7 I/O	(1) I	37	R23 I/O	A11 I
6	R66/AN6 I/O	(1) I	38	R22 I/O	A10 I
7	R65/AN5 I/O	(1) I	39	R21 I/O	A9 I
8	R64/AN4 I/O	(1) I	40	R20 I/O	A8 I
9	R63/AN3 I	(1) I	41	R17 I/O	A7 I
10	R62/AN2 I	(1) I	42	R16 I/O	A6 I
11	R61/AN1 I	(1) I	43	R15 I/O	A5 I
12	R60/AN0 I	(1) I	44	R14 I/O	A4 I
13	R57/PWM1 I/O	(1) I	45	R13 I/O	A3 I
14	R56/PWM0 I/O	(1) I	46	R12 I/O	A2 I
15	R55/BUZ I/O	(1) I	47	R11 I/O	A1 I
16	R54/WDTO I/O	(1) I	48	R10 I/O	A0 I
17	R53/ $\overline{\text{SRDY}}$ I/O	(1) I	49	R07 I/O	O7 I/O
18	R52/SCLK I/O	(1) I	50	R06 I/O	O6 I/O
19	R51/SOUT I/O	(1) I	51	R05 I/O	O5 I/O
20	R50/SIN I/O	(1) I	52	R04 I/O	O4 I/O
21	R47/T3O I/O	(2) I	53	R03 I/O	O3 I/O
22	R46/T1O I/O	(2) I	54	R02 I/O	O2 I/O
23	R45/ $\overline{\text{EC2}}$ I/O	$\overline{\text{CE}}$ I	55	R01 I/O	O1 I/O
24	R44/ $\overline{\text{EC0}}$ I/O	$\overline{\text{OE}}$ I	56	R00 I/O	O0 I/O
25	R43/INT3 I/O	(1) I	57	R37 I/O	(1) I
26	R42/INT2 I/O	(1) I	58	R36 I/O	(1) I
27	R41/INT1 I/O	(1) I	59	R35 I/O	(1) I
28	R40/INT0 I/O	(1) I	60	R34 I/O	(1) I
29	RESET I	(1) I	61	R33 I/O	(1) I
30	X <sub>IN</sub> I	(1) I	62	R32 I/O	(1) I
31	X <sub>OUT</sub> O	(3) O	63	R31 I/O	(1) I
32	V <sub>SS</sub> -	V <sub>SS</sub> -	64	R30 I/O	(1) I

## NOTES:

- (1) These pins must be connected to V<sub>SS</sub>, because these pins are input ports during programming, program verify and reading  
(2) These pins must be connected to V<sub>DD</sub>.  
(3) X<sub>OUT</sub> pin must be opened during programming.

I/O: Input/Output Pin  
I: Input Pin  
O: Output Pin

## 64QFP Package for GMS81516AT

Pin No.	MCU Mode	OTP Mode	Pin No.	MCU Mode	OTP Mode
1	R65/AN5 I/O	(1) I	33	R21 I/O	A9 I
2	R64/AN4 I/O	(1) I	34	R20 I/O	A8 I
3	R63/AN3 I	(1) I	35	R17 I/O	A7 I
4	R62/AN2 I	(1) I	36	R16 I/O	A6 I
5	R61/AN1 I	(1) I	37	R15 I/O	A5 I
6	R60/AN0 I	(1) I	38	R14 I/O	A4 I
7	R57/PWM1 I/O	(1) I	39	R13 I/O	A3 I
8	R56/PWM0 I/O	(1) I	40	R12 I/O	A2 I
9	R55/BUZ I/O	(1) I	41	R11 I/O	A1 I
10	R54/WDTO I/O	(1) I	42	R10 I/O	A0 I
11	R53/SRDY I/O	(1) I	43	R07 I/O	O7 I/O
12	R52/SCLK I/O	(1) I	44	R06 I/O	O6 I/O
13	R51/SOUT I/O	(1) I	45	R05 I/O	O5 I/O
14	R50/SIN I/O	(1) I	46	R04 I/O	O4 I/O
15	R47/T3O I/O	(2) I	47	R03 I/O	O3 I/O
16	R46/T1O I/O	(2) I	48	R02 I/O	O2 I/O
17	R45/EC2 I/O	CE I	49	R01 I/O	O1 I/O
18	R44/EC0 I/O	OE I	50	R00 I/O	O0 I/O
19	R43/INT3 I/O	(1) I	51	R37 I/O	(1) I
20	R42/INT2 I/O	(1) I	52	R36 I/O	(1) I
21	R41/INT1 I/O	(1) I	53	R35 I/O	(1) I
22	R40/INT0 I/O	(1) I	54	R34 I/O	(1) I
23	RESET I	(1) I	55	R33 I/O	(1) I
24	XIN I	(1) I	56	R32 I/O	(1) I
25	XOUT O	(3) O	57	R31 I/O	(1) I
26	VSS -	VSS -	58	R30 I/O	(1) I
27	R27 I/O	A15 I	59	VDD -	VDD -
28	R26 I/O	A14 I	60	MP I	VPP -
29	R25 I/O	A13 I	61	AVSS I	(1) I
30	R24 I/O	A12 I	62	AVREF I	(1) I
31	R23 I/O	A11 I	63	R67/AN7 I/O	(1) I
32	R22 I/O	A10 I	64	R66/AN6 I/O	(1) I

## NOTES:

- (1) These pins must be connected to V<sub>SS</sub>, because these pins are input ports during programming, program verify and reading
- (2) These pins must be connected to V<sub>DD</sub>.
- (3) X<sub>OUT</sub> pin must be opened during programming.

I/O: Input/Output Pin  
 I: Input Pin  
 O: Output Pin

## 64LQFP Package for GMS81516AT

Pin No.	MCU Mode	OTP Mode	Pin No.	MCU Mode	OTP Mode
1	R63/AN3 I	(1) I	33	R17 I/O	A7 I
2	R62/AN2 I	(1) I	34	R16 I/O	A6 I
3	R61/AN1 I	(1) I	35	R15 I/O	A5 I
4	R60/AN0 I	(1) I	36	R14 I/O	A4 I
5	R57/PWM1 I/O	(1) I	37	R13 I/O	A3 I
6	R56/PWM0 I/O	(1) I	38	R12 I/O	A2 I
7	R55/BUZ I/O	(1) I	39	R11 I/O	A1 I
8	R54/WDTO I/O	(1) I	40	R10 I/O	A0 I
9	R53/SRDY I/O	(1) I	41	R07 I/O	O7 I/O
10	R52/SCLK I/O	(1) I	42	R06 I/O	O6 I/O
11	R51/SOUT I/O	(1) I	43	R05 I/O	O5 I/O
12	R50/SIN I/O	(1) I	44	R04 I/O	O4 I/O
13	R47/T3O I/O	(2) I	45	R03 I/O	O3 I/O
14	R46/T1O I/O	(2) I	46	R02 I/O	O2 I/O
15	R45/EC2 I/O	CE I	47	R01 I/O	O1 I/O
16	R44/EC0 I/O	OE I	48	R00 I/O	O0 I/O
17	R43/INT3 I/O	(1) I	49	R37 I/O	(1) I
18	R42/INT2 I/O	(1) I	50	R36 I/O	(1) I
19	R41/INT1 I/O	(1) I	51	R35 I/O	(1) I
20	R40/INT0 I/O	(1) I	52	R34 I/O	(1) I
21	RESET I	(1) I	53	R33 I/O	(1) I
22	XIN I	(1) I	54	R32 I/O	(1) I
23	XOUT O	(3) O	55	R31 I/O	(1) I
24	VSS -	VSS -	56	R30 I/O	(1) I
25	R27 I/O	A15 I	57	VDD -	VDD -
26	R26 I/O	A14 I	58	MP I	VPP -
27	R25 I/O	A13 I	59	AVSS I	(1) I
29	R24 I/O	A12 I	60	AVREF I	(1) I
29	R23 I/O	A11 I	61	R67/AN7 I/O	(1) I
30	R22 I/O	A10 I	62	R66/AN6 I/O	(1) I
31	R21 I/O	A9 I	63	R65/AN5 I/O	(1) I
32	R20 I/O	A8 I	64	R64/AN4 I/O	(1) I

## NOTES:

- (1) These pins must be connected to V<sub>SS</sub>, because these pins are input ports during programming, program verify and reading
- (2) These pins must be connected to V<sub>DD</sub>.
- (3) X<sub>OUT</sub> pin must be opened during programming.

I/O: Input/Output Pin  
 I: Input Pin  
 O: Output Pin

**PIN FUNCTION (OTP Mode)****V<sub>PP</sub> (Program Voltage)**

V<sub>PP</sub> is the input for the program voltage for programming the EPROM.

 **$\overline{\text{CE}}$  (Chip Enable)**

$\overline{\text{CE}}$  is the input for programming and verifying internal EPROM.

 **$\overline{\text{OE}}$  (Output Enable)**

$\overline{\text{OE}}$  is the input of data output control signal for verify.

**A<sub>0</sub>~A<sub>15</sub> (Address Bus)**

A<sub>0</sub>~A<sub>15</sub> are address input pins for internal EPROM.

**O<sub>0</sub>~O<sub>7</sub> (EPROM Data Bus)**

These are data bus for internal EPROM.

**PROGRAMMING**

The GMS81516AT has address A<sub>0</sub>~A<sub>15</sub> pins. Therefore, the programmer just program the data (from 4000<sub>H</sub> to 7FFF<sub>H</sub>) into the GMS81516AT OTP device, during addresses A<sub>14</sub>, A<sub>15</sub> must be pulled to a logic high. When the programmer write the data from 4000<sub>H</sub> to 7FFF<sub>H</sub>, consequently, the data actually will be written into addresses C000<sub>H</sub> to FFFF<sub>H</sub> of the OTP device.

1. The data format to be programmed is made up of Motorola S1 format.

Ex) "Motorola S1" format;

**S0080000574154434880**

**S1244000E1FF3BFF04A13F8F06E101711B821B1BE01D1B3B191BF6181BF01C1BFF081BFF0AEO**

**S12440211BF5091BFF0B1BFF3F1B003E1B003D1B003C1BFF3B1B003A1BFF391BFF381BFF353D**

:

:

**S1057FF2983FB2**

**S1057FFEFF3F3F**

**S9030000FC**

2. Down load above data into programmer from PC.

3. Programming the data from address 4000<sub>H</sub> to 7FFF<sub>H</sub> into the OTP MCU, the data must be turned over respectively, and then record the data. When read the data, it also must be turned over.

Ex) 00(00000000)→FF(11111111), 76(01110110)→89(10001001), FF(11111111)→00(00000000) etc.

4. Of course, the check sum is result of the sum of whole data from address 4000<sub>H</sub> to 7FFF<sub>H</sub> in the file (not reverse data of OTP MCU).

\* When GMS81516AT shipped, the blank data of GMS81516AT is initially 00<sub>H</sub> (not FF<sub>H</sub>).

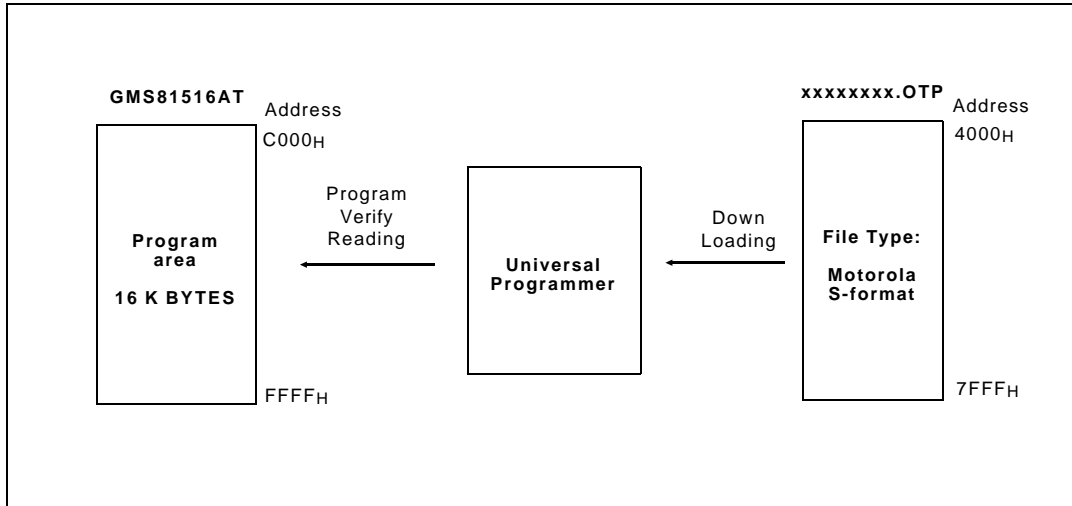

**Programming Flow**

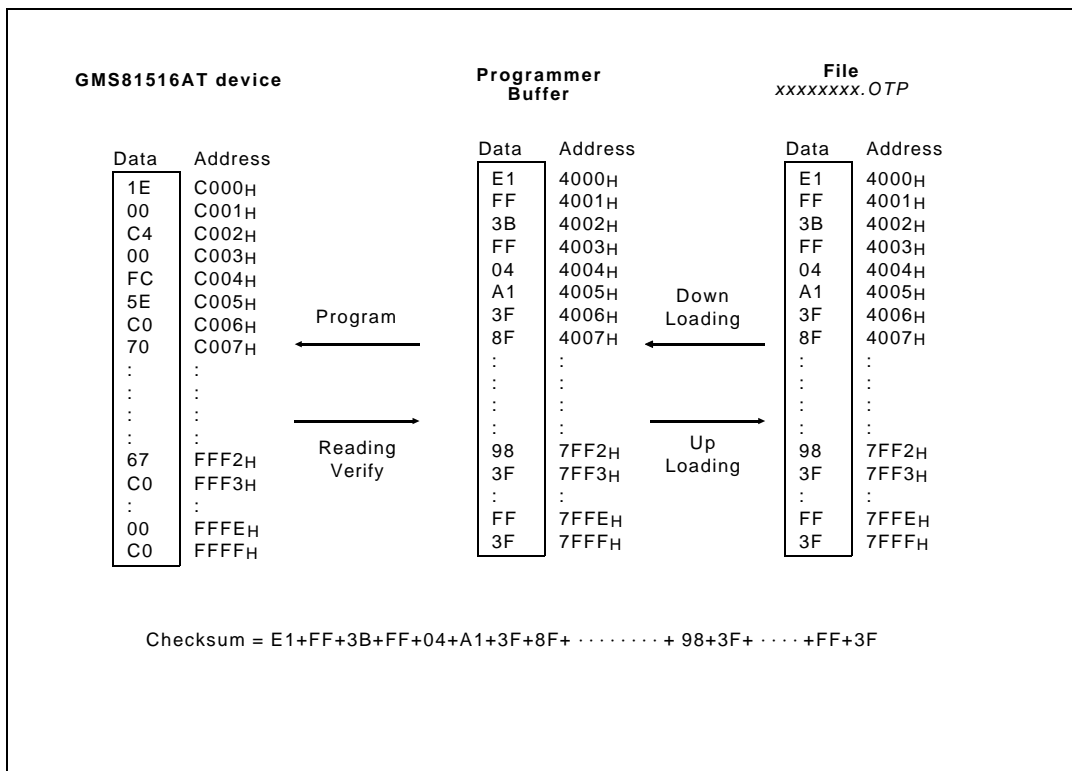

**Programming Example**



**DEVICE OPERATION MODE**(T<sub>A</sub> = 25°C ± 5°C)

Mode	$\overline{CE}$	$\overline{OE}$	A0-A15	V <sub>PP</sub>	V <sub>DD</sub>	O0-O7
Read	X		X	V <sub>DD</sub>	5.0V	D <sub>OUT</sub>
Output Disable	V <sub>IH</sub>	V <sub>IH</sub>	X	V <sub>DD</sub>	5.0V	Hi-Z
Programming	V <sub>IL</sub>	V <sub>IH</sub>	X	V <sub>PP</sub>	V <sub>DD</sub>	D <sub>IN</sub>
Program Verify	X		X	V <sub>PP</sub>	V <sub>DD</sub>	D <sub>OUT</sub>

## NOTES:

1. X = Either V<sub>IL</sub> or V<sub>IH</sub>
2. See DC Characteristics Table for V<sub>DD</sub> and V<sub>PP</sub> voltages during programming.

**DC CHARACTERISTICS**(V<sub>SS</sub>=0 V, T<sub>A</sub> = 25°C ± 5°C)

Symbol	Item	Min	Typ	Max	Unit	Test condition
V <sub>PP</sub>	Intelligent Programming	12.0	-	13.0	V	
V <sub>DD</sub> (1)	Intelligent Programming	5.75	-	6.25	V	
I <sub>PP</sub> (2)	V <sub>PP</sub> supply current			50	mA	$\overline{CE}=V_{IL}$
I <sub>DD</sub> (2)	V <sub>DD</sub> supply current			30	mA	
V <sub>IH</sub>	Input high voltage	0.8 V <sub>DD</sub>			V	
V <sub>IL</sub>	Input low voltage			0.2 V <sub>DD</sub>	V	
V <sub>OH</sub>	Output high voltage	V <sub>DD</sub> -1.0			V	I <sub>OH</sub> = -2.5 mA
V <sub>OL</sub>	Output low voltage			0.4	V	I <sub>OL</sub> = 2.1 mA
I <sub>IL</sub>	Input leakage current			5	uA	

## NOTES:

1. V<sub>DD</sub> must be applied simultaneously or before V<sub>PP</sub> and removed simultaneously or after V<sub>PP</sub>.
2. The maximum current value is with outputs O<sub>0</sub> to O<sub>7</sub> unloaded.

**SWITCHING WAVEFORMS**

WAVEFORM	INPUTS	OUTPUTS
	Must be steady	Will be steady
	May change from H to L	Will be changing from H to L
	May change from L to H	Will be changing from L to H
	Do not care any change permitted	Changing state unknown
	Does not apply	Center line is high impedance "Off" state

**READING WAVEFORMS**

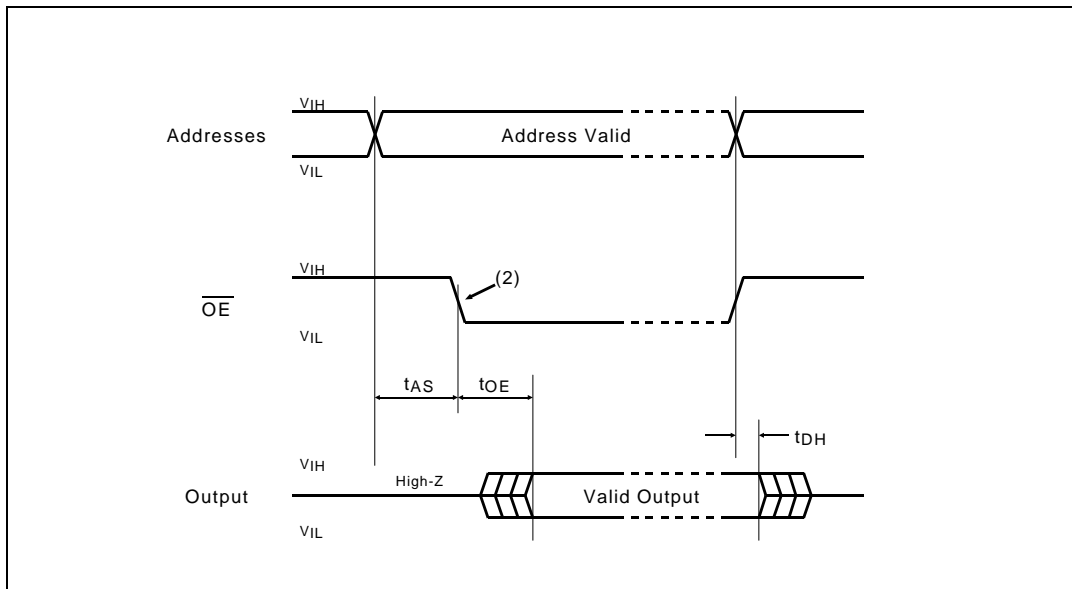

**NOTES:**

1. The input timing reference level is 1.0 V for a V<sub>IL</sub> and 4.0V for a V<sub>VIH</sub> at V<sub>DD</sub>=5.0V
2. To read the output data, transition requires on the OE from the high to the low after address setup time t<sub>AS</sub>.



PROGRAMMING ALGORITHM WAVEFORMS

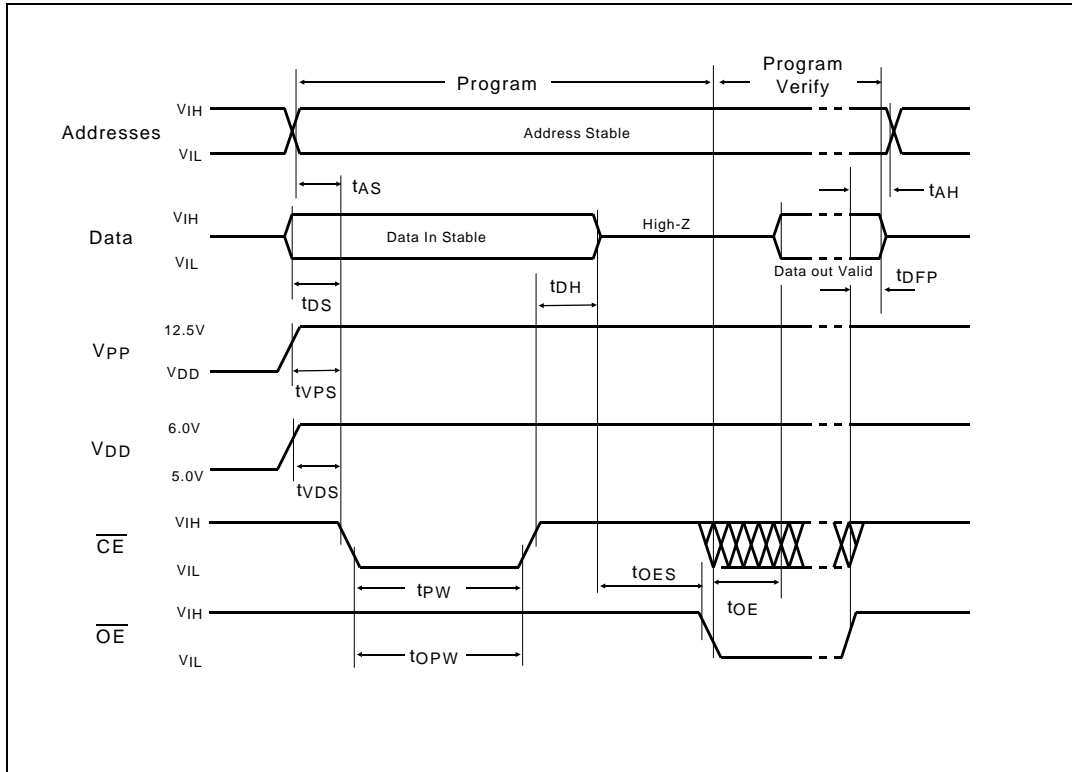

NOTES:

1. The input timing reference level is 1.0 V for a  $V_{IL}$  and 4.0V for a  $V_{IH}$  at  $V_{DD}=5.0V$

**AC READING CHARACTERISTICS**(V<sub>SS</sub>=0 V, T<sub>A</sub> = 25°C ± 5°C)

Symbol	Item	Min	Typ	Max	Unit	Test condition
t <sub>AS</sub>	Address setup time	2			us	
t <sub>OE</sub>	Data output delay time			200	ns	
t <sub>DH</sub>	Data hold time	0			ns	

## NOTES:

- V<sub>DD</sub> must be applied simultaneously or before V<sub>PP</sub> and removed simultaneously or after V<sub>PP</sub>.

**AC PROGRAMMING CHARACTERISTICS**(V<sub>SS</sub>=0 V, T<sub>A</sub> = 25°C ± 5°C; See DC Characteristics Table for V<sub>DD</sub> and V<sub>PP</sub> voltages.)

Symbol	Item	Min	Typ	Max	Unit	Condition* (Note 1)
t <sub>AS</sub>	Address set-up time	2			us	
t <sub>OES</sub>	$\overline{\text{OE}}$ set-up time	2			us	
t <sub>DS</sub>	Data setup time	2			us	
t <sub>AH</sub>	Address hold time	0			us	
t <sub>DH</sub>	Data hold time	1			us	
t <sub>DFP</sub>	Output disable delay time	0			us	
t <sub>VPS</sub>	V <sub>PP</sub> setup time	2			us	
t <sub>VDS</sub>	V <sub>DD</sub> setup time	2			us	
t <sub>PW</sub>	Program pulse width	0.95	1.0	1.05	ms	Intelligent
t <sub>OPW</sub>	$\overline{\text{CE}}$ pulse width when over programming	2.85		78.75	ms	(Note 2)
t <sub>OE</sub>	Data output delay time			200	ns	

## \*AC CONDITIONS OF TEST

Input Rise and Fall Times (10% to 90%) . . . . . 20 ns  
 Input Pulse Levels . . . . . 0.45V to 4.55V  
 Input Timing Reference Level . . . . . 1.0V to 4.0V  
 Output Timing Reference Level . . . . . 1.0V to 4.0V

## NOTES:

- V<sub>DD</sub> must be applied simultaneously or before V<sub>PP</sub> and removed simultaneously or after V<sub>PP</sub>.
- The length of the overprogram pulse may vary from 2.85 msec to 78.75 msec as a function of the iteration counter value X. Refer to page 13.

## Intelligent Programming Algorithm

