

Service Manual

Industrial Camera GP-MF802



Camera Cable : Option
Lens : Option

SPECIFICATIONS

Pick-up Device :	Progressive Scanning Interline Transfer CCD with 659 (H) x 494 (V) pixels.
Image Size :	1/3" (6.3 (H) x 6.4 (V) mm) 2 : 1 interlace 1-line interlace (Frame accumulation) 2 : 1 interlace 2-line interlace (Field accumulation) 2-line sequential (at non-interlaced external HD/VD)
Synchronization :	internal or external (Selectable automatically) Internal : Built-in sync generator External : 4.0 V[p-p] / 75 Ω Horizontal drive and vertical drive pulses for 2 : 1 interlace or sequential scanning
External Reset :	External signal (4.0 V[p-p]/75 Ω, negative) supplied to EXT VD IN connector can be used as reset signal
Horizontal Resolution :	480 lines at center
Minimum Illumination :	6.5 lx (0.65 footcandles) at F1.4, (Manual Gain Max, γ ON, 2 : 1 interlace, without shutter)
Signal to Noise Ratio :	56 dB Typical (Fix Gain, γ OFF, 2:1 interlace without shutter)
Electronic Shutter :	7-step (1/100 to 1/8,000) at normal. 4-step (1/2,000 to 1/16,000) at Shutter Trigger-A. Approx. 1/2,000 at Shutter Trigger-B.
Lens Mount :	C-mount
Vibration Resistance :	8 G (10 Hz - 150 Hz), (2 hours each for three axes)(IEC 68)
Shock Resistance :	80 G (IEC 68) *IEC=International Electrotechnical Commission
Power Source :	12V DC, 190 mA
Ambient Temperature :	-10°C - +50°C (14°F - 122°F)

Panasonic®

© 1997 Matsushita Communication Industrial Co., Ltd.
All rights reserved. Unauthorized copying and distribution is a violation of law.

WARNING

This service information is designed for experienced repair technicians only and is not designed for use by the general public.

It does not contain warnings or cautions to advise non-technical individuals of potential dangers in attempting to service a product.

Products powered by electricity should be serviced or repaired only by experienced professional technicians. Any attempt to service or repair the product or products dealt with in this service information by anyone else could result in serious injury or death.

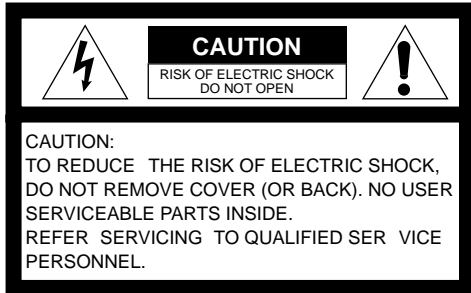

This symbol warns the user that uninsulated voltage within the unit may have sufficient magnitude to cause electric shock. Therefore, it is dangerous to make any kind of contact with any inside part of this unit.



This symbol alerts the user that important literature concerning the operation and maintenance of this has been included. Therefore, it should be read carefully in order to avoid any problems.

IMPORTANT SAFETY NOTICE

There are special components used in this equipment which are important for safety . These parts are indicated by the "  " mark on the schematic diagram and the replacement parts list. It is essential that these critical parts should be replaced with manufacturer's specified parts to prevent shock, fire, or other hazards. Do not modify the original design without permission of manufacture.

Dimensions : 44(W) x 29(H) x 82(D) mm [1-3/4"(W) x 1-1/8"(H) x 3-1/4"(D)] without mount adaptor

Weight : 165g (0.36 lbs.) without lens

Dimensions and weight indicated are approximate values.

Specifications are subject to change without notice.

OPTIONAL ACCESSORIES

Camera Cable GP-CA83

GP-CA82

GP-CA81

CONTENTS

Major Operating Controls and Their Functions	1
Circuit Description	
IC Description	5
Adjustment Procedure	9
Appearance of ICs, Transistors and Diodes	14
Location of Test Points and Adjusting Controls	15
Chip Components	16
Block Diagram	17
Schematic Diagram	
Drive Board	18
Power Board	21
Rear Board	22
Sensor Board	25
Conductor View	
Drive Board	19
Power Board	20
Rear Board	23
Sensor Board	24
Exploded View	26
Replacement Parts List	27

MAJOR OPERATING CONTROLS AND THEIR FUNCTIONS

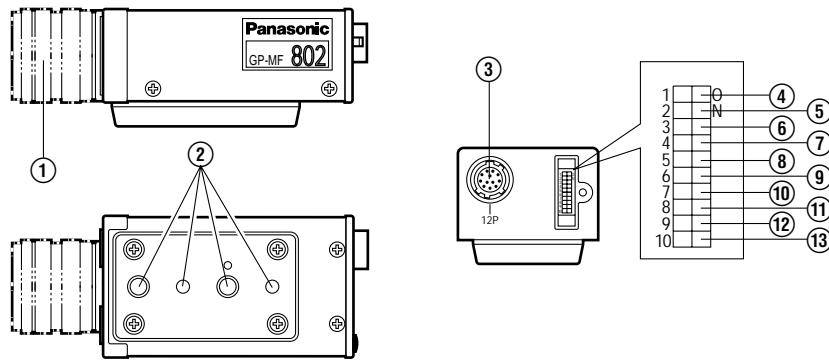

1. Manual Iris Lens (Optional)

2. Mounting Holes

There are two screw holes (1/4") for mounting the camera on a tripod, and two more screw holes (No.8-32 UNC) for mounting the camera on a mounting bracket.

3. Camera Connector (12P)

Connect the optional camera cable GP-CA81 , GP-CA82, or GP-CA83 to it.

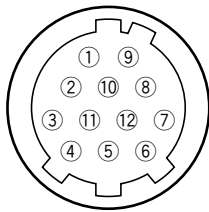

CAUTION: CONNECT THIS TO A 12V DC CLASS 2 POWER SUPPLY ONLY.

Pin No.	Description
1	Ground
2	+12V DC In
3	Ground for Video Out 1
4	Video Out 1
5	Ground for HD
6	External HD
7	External VD
8	Ground for Video Out 2
9	Video Out 2
10	Ground for Clock
11	Clock Out
12	Ground for VD

4. Switch 1 (1/ON) 1 ON

This switch is used with switch 2 to select a field or frame accumulation. Switch position combinations and accumulations are shown in the table below;

	Swich 1	OFF	ON	OFF	ON
	Switch 2	OFF	OFF	ON	ON
Accumulation	Field Accumulation 1 (2:1 Interlace)	Field Accumulation 2 (2:1 Interlace)	Field Mix (2:1 Interlace)	Frame Accumulation (Full frame with no Interlace)	
Video 1	Field A (Even) Field B (Even)	Field A (Odd) Field B (Even)	Field A (Even + Odd) Field B (Odd + Even)	Sequential	
Video 2	Field A (Odd) Field B (Odd)	Field A (Even) Field B (Odd)	No Output	No Output	

5. Switch 2 (2/ON) 2 ON

This switch is used with switch 1 to select a field or frame accumulation. Switch position combinations and accumulations are shown in the table above.

6. Switch 3 (3/ON) 3 ON

This switch is used to set the frame reset (shutter trigger) to on or off.

In case of frame reset off, you can select a shutter speed using switch 4, switch 5, and switch 6.

Shutter speeds and combinations of the switches in case of frame reset off are shown in the table below;

Switch			Shutter Speed
6	5	4	
OFF	OFF	OFF	NORMAL
ON	OFF	OFF	1/100
OFF	ON	OFF	1/250
ON	ON	OFF	1/500
OFF	OFF	ON	1/1000
ON	OFF	ON	1/2000
OFF	ON	ON	1/4000
ON	ON	ON	1/8000

In case of frame reset on, you can select a shutter speed or long time exposure mode using switch 4, switch 5, and switch 6.

Shutter speeds and combinations of the switches in case of frame reset on are shown in the table below;

Switch			Shutter Speed
6	5	4	
OFF	OFF	OFF	The long time exposure mode
ON	OFF	OFF	
OFF	ON	OFF	
ON	ON	OFF	
OFF	OFF	ON	1/2000
ON	OFF	ON	1/4000
OFF	ON	ON	1/8000
ON	ON	ON	1/16000

Note: The accurate shutter speed function cannot be expected in non-interlaced synchronization.

7. Switch 4 (4/ON) 4 ON

Set this switch with switch 5 and switch 6 as shown in the tables above.

8. Switch 5 (5/ON) 5 ON

Set this switch with switch 4 and switch 6 as shown in the tables above.

9. Switch 6 (6/ON) 6 ON

Set this switch with switch 4 and switch 5 as shown in the tables above.

10. Switch 7 (7/ON) 7 ON

Set this switch to ON to terminate the external HD signals with 75Ω.

11. Switch 8 (8/ON) 8 ON

Set this switch to ON to terminate the external VD signals with 75Ω.

12. Switch 9 (9/ON) 9 ON

This switch is used to set long time exposure mode to ON or OFF.

Set this switch to ON only when switch 3 is set to ON with switches 4, 5 and 6 in the specified positions.

This switch changes the AC/DC coupling to AC coupling when OFF is selected or to DC coupling when ON is selected.

13. Switch 10 (10/ON) 10 ON

This switch is used to set the clock out function to ON or OFF.

PREPARATIONS

1. Power Supply for Camera

Prepare a regulated DC power supply of 12 V ± 10 %, 190 mA or more, and rated CLASS 2.

2. Lenses

Be sure to use an optional manual iris lens that meets the following items.

Focus : Adjustable

Lens Weight : Less than 300 g (0.66 lbs.)

Note: If the lens weight exceed 300 g (0.66 lbs.), the camera and lens should be secured.

Mount : C-mount

Lens mount should be as shown in the diagram, otherwise the lens will damage the camera.

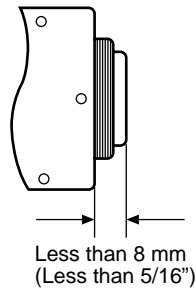

3. Switch Cover Removal

Caution: The following preparations should be made by a qualified service person or system installer.

To set switch 1, 2, 3, 4, 5, 6, 7, 8, 9 or 10, remove the switch cover fixing screw on the rear panel as shown below.

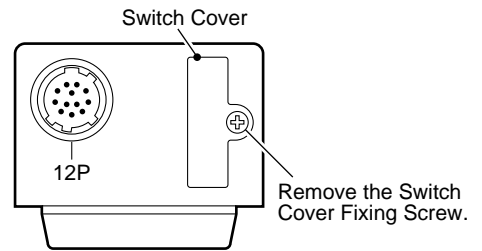

SYSTEM CONNECTIONS

Caution: Set the power switches of all units to OFF before connection.

1. Connect the optional camera cable GP-CA81 between the connector of this camera and the 12V DC Class 2 power supply (not provided as an accessory).
2. Connect the video connector of the GP-CA81 to the video monitor.

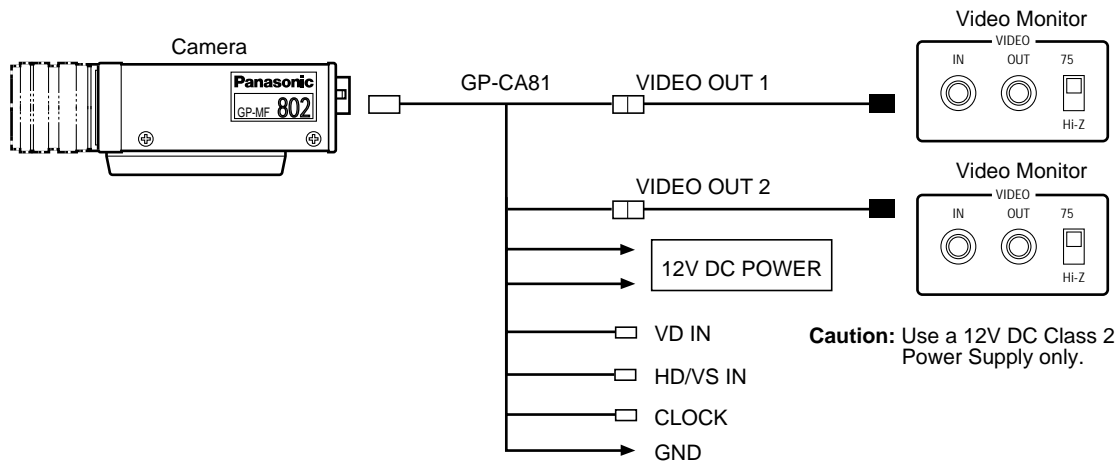

INSTALLATION OF CAMERA

1. Bottom Mounting

This camera is originally designed for bottom mounting. The hole is the standard photographic pan-head screw size (1/4").

2. Top Mounting

Remove the mount adaptor on the bottom of the camera by removing 4 fixing screws. Attach the mount adaptor to the top as shown in the illustration, then mount the camera on the mounting bracket.

Make sure that the 4 original screws are used when mounting the mount adaptor; longer type screws will break the inner component.

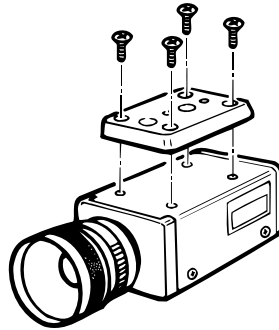

EXTERNAL SYNCHRONIZATION

1. 2 : 1 Interlace

The GP-MF802 works in 2 : 1 interlace mode when external 2 : 1 interlaced HD and VD signals are supplied to pin 6 and pin 7 of the camera connector (12-pin).

2. Non-interlace

The GP-MF802 works in non-interlace mode when external non-interlaced HD and VD signals are supplied to pin 6 and pin 7 of the camera connector (12-pin).

Note: If the picture appears disturbed, be sure to match the phases of falling edges of the external HD and VD.

PREVENTION OF BLOOMING AND SMEAR

When the camera is aimed at spotlights, other bright lights, or light reflecting objects, a vertical stripe (smear) or blooming may appear. The camera should be operated carefully in the vicinity of extremely bright objects to avoid smear or blooming.

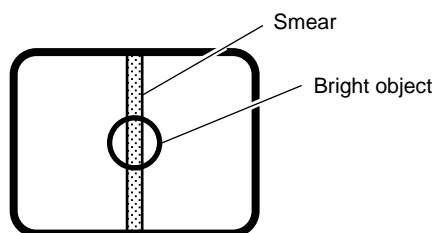

CIRCUIT DESCRIPTION

IC Description

1. Drive Board

1.1. IC5 on the Drive Board is using the CCD Drive Pulse Generator IC YWBU121070A.

Description of this IC is as follows:

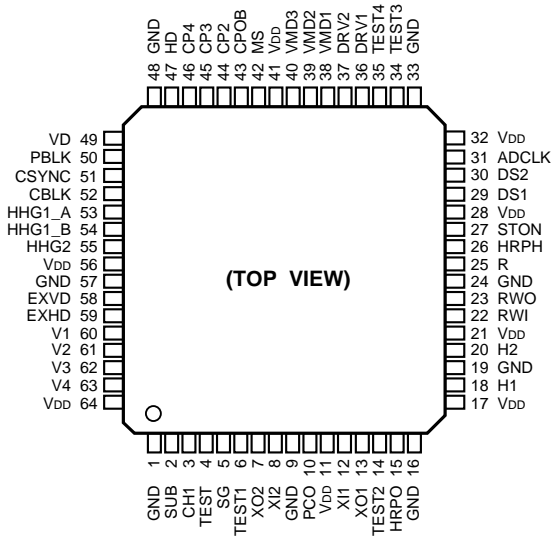

Pin	Name	I/O	Description
29	DS1	O	CDS Sample Hold Pulse output terminals.
30	DS2	O	
31	ADCLK	O	AD Clock Pulse output terminal.
32	VDD	-	Power supply terminal.
33	GND	-	Ground terminal.
34	TEST3	I	Test signal input terminals.
35	TEST4	I	
36	DRV1	I	DRV signal input terminals.
37	DRV2	I	
38	VMD1	I	VMD signal input terminals.
39	VMD2	I	
40	VMD3	I	
41	VDD	-	Power supply terminal.
42	MS	I	MS signal input terminal.
43	CPOB	O	OB (Optical Black) Clamp Pulse output terminal.
44	CP2	O	Clamp Pulse output terminals.
45	CP3	O	
46	CP4	O	
47	HD	O	Horizontal Drive signal output terminal.
48	GND	-	Ground terminal.
49	VD	O	Vertical Drive signal output terminal.
50	PBLK	O	Pre Blanking Pulse output terminal.
51	CSYNC	O	Composite Sync signal output terminal.
52	CBLK	O	Composite Blanking Pulse output terminal.
53	HHG1_A	O	HHG1_A signal output terminal.
54	HHG1_B	O	HHG1_B signal output terminal.
55	HHG2	O	HHG2 signal output terminal.
56	VDD	-	Power supply terminal.
57	GND	-	Ground terminal.
58	EXVD	I	External VD signal input terminal.
59	EXHD	I	External HD signal input terminal.
60	V1	O	Φ V1 Transfer Pulse output terminal.
61	V2	O	Φ V2 Transfer Pulse output terminal.
62	V3	O	Φ V3 Transfer Pulse output terminal.
63	V4	O	Φ V4 Transfer Pulse output terminal.
64	VDD	-	Power supply terminal.

Pin	Name	I/O	Description
1	GND	-	Ground terminal.
2	SUB	O	Electronic Shutter Pulse output terminal.
3	CH1	O	Charge Pulse output terminal for Φ V1.
4	TEST	I	Test mode switching terminal.
5	SG	O	Sensor Gate Pulse output terminal.
6	TEST1	I	Test signal input terminal.
7	XO2	O	Crystal Oscillator 2 connecting terminals.
8	XI2	I	
9	GND	-	Ground terminal.
10	PCO	O	Phase Comparator output terminal.
11	VDD	-	Power supply terminal.
12	XI1	I	Crystal Oscillator 1 connecting terminals.
13	XO1	O	
14	TEST2	I	Test signal input terminal.
15	HRPO	I	HRPO signal input terminal.
16	GND	-	Ground terminal.
17	VDD	-	Power supply terminal.
18	H1	O	Φ H1 Transfer Pulse output terminal.
19	GND	-	Ground terminal.
20	H2	O	Φ H2 Transfer Pulse output terminal.
21	VDD	-	Power supply terminal.
22	RWI	I	Reset Pulse Width Adjust signal input terminal.
23	RWO	O	Reset Pulse Width Adjust signal output terminal.
24	GND	-	Ground terminal.
25	R	O	Reset Pulse output terminal.
26	HRPH	I	HRPH signal input terminal.
27	STON	I	STON signal input terminal.
28	VDD	-	Power supply terminal.

1.2. IC6 on the Drive Board is using the CCD Vertical Driver IC MN3112SA.

Description of this IC is as follows:

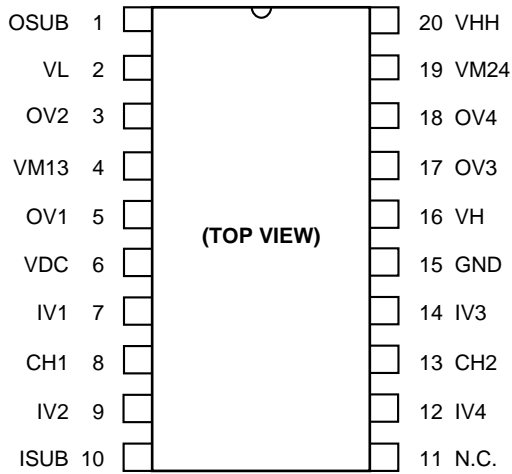

Pin	Name	I/O	Description
1	OSUB	O	Vsub signal output terminal.
2	VL	-	VL voltage supply terminal.
3	OV2	O	Vertical Pulse 2 output terminal.
4	VM13	I	VM13 voltage supply terminal.
5	OV1	O	Vertical Pulse 1 output terminal.
6	VDC	-	Power supply.
7	IV1	I	Vertical Pulse 1 input terminal.
8	CH1	I	Horizontal Pulse 1 input terminal.
9	IV2	I	Vertical Pulse 2 input terminal.
10	ISUB	I	Vsub signal input terminal.
11	N.C.	-	Non Connection.
12	IV4	I	Vertical Pulse 4 input terminal.
13	CH2	I	Horizontal Pulse 2 input terminal.
14	IV3	I	Vertical Pulse 3 input terminal.
15	GND	-	Ground terminal.
16	VH	-	VH voltage supply terminal.
17	OV3	O	Vertical Pulse 3 output terminal.
18	OV4	O	Vertical Pulse 4 output terminal.
19	VM24	-	VM24 voltage supply terminal.
20	VHH	-	VHH voltage supply terminal.

1.3. IC12 and IC13 on the Drive Board and IC8 on the Power Board are using the Single Inverter IC YWTC7S04FUL.

Description of this IC is as follows:

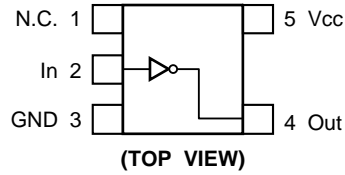

Truth Table

Input	Output
L	H
H	L

1.4. IC8 on the Drive Board and IC9 on the Power Board are using the Single 2-Input AND Gate IC YWTC7S08FUL.

Description of this IC is as follows:

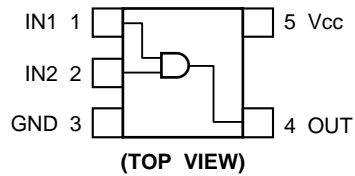

Truth Table

Inputs		Output
IN1	IN2	Output
L	L	L
H	L	L
L	H	L
H	H	H

1.5. IC10 on the Drive Board is using the Single 2-Channel Multiplexer/Demultiplexer IC YWTC4W53FUL.

Description of this IC is as follows:

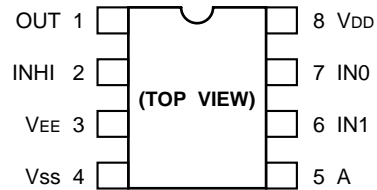

Truth Table

INPUTS		OUT
INHI	A	OUT
L	L	IN0
L	H	IN1
H	*	None

*: Don't Care.

1.6. IC7 on the Drive Board is using the Three-Terminal 9V Voltage Regulator IC YW78L09UATE2.

Description of this IC is as follows:

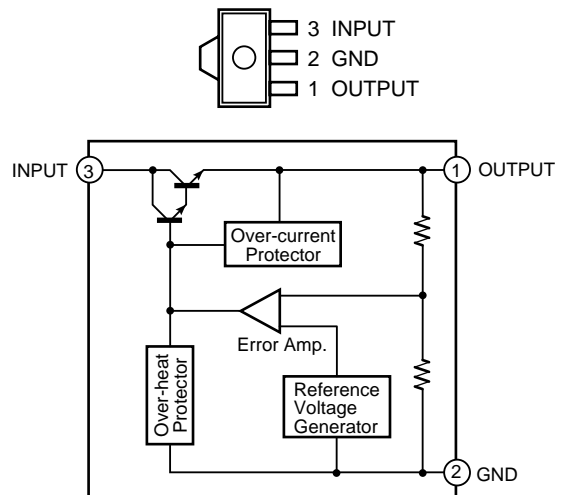

2. Power Board

2.1. IC3 and IC6 on the Power Board are using the CCD Black & White Camera One-chip Process IC YWCXA1310AQ.

Description of this IC is as follows:

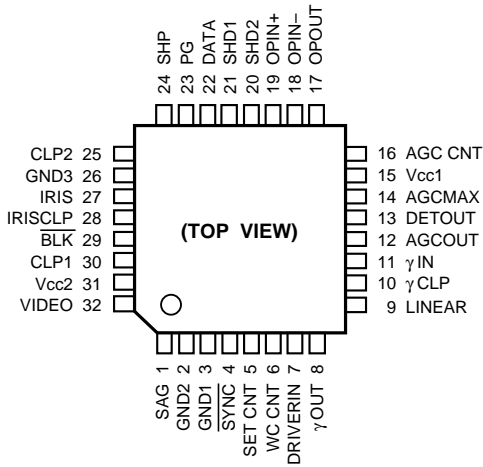

Pin	Name	I/O	Description
1	SAG	I	Sag Compensation signal input terminal.
2	GND2	-	Ground terminal.
3	GND1	-	Ground terminal.
4	SYNC	I	Sync signal input terminal.
5	SET CNT	I	Setup Level control terminal.
6	WC CNT	I	White Clip Level control terminal.
7	DRIVERIN	I	Driver signal input terminal.
8	γ OUT	O	Gamma Correction signal output terminal.
9	LINEAR	O	Linear (Gamma-Off) signal output terminal.
10	γ CLP	I	Gamma Clamp Pulse input terminal.
11	γ IN	I	Gamma Correction signal input terminal.
12	AGC OUT	O	AGC signal output terminal.
13	DETOUT	O	AGC Detect signal output terminal.
14	AGC MAX	I	AGC Amp. Max Gain control terminal.
15	Vcc1	-	Power supply terminal.
16	AGC CNT	I	AGC Control signal input terminal.
17	OPOUT	O	Operational Amp. output terminal.
18	OPIN-	I	Operational Amp. - input terminal.
19	OPIN+	I	Operational Amp. + input terminal.
20	SHD2	I	Sample Hold Pulse input terminal.
21	SHD1	I	Sample Hold Pulse input terminal.
22	DATA	I	CCD signal input terminal.
23	PG	I	CCD signal input terminal.
24	SHP	I	Sample Hold Pulse input terminal.
25	CLP2	I	Clamp Pulse input terminal.
26	GND3	-	Ground terminal.
27	IRIS	O	Iris Control signal output terminal.
28	IRISCLP	I	Iris Clamp Pulse input terminal.
29	BLK	I	Blanking Pulse input terminal.
30	CLP1	I	Clamp Pulse input terminal.
31	Vcc2	-	Power supply terminal.
32	VIDEO	O	Video signal output terminal.

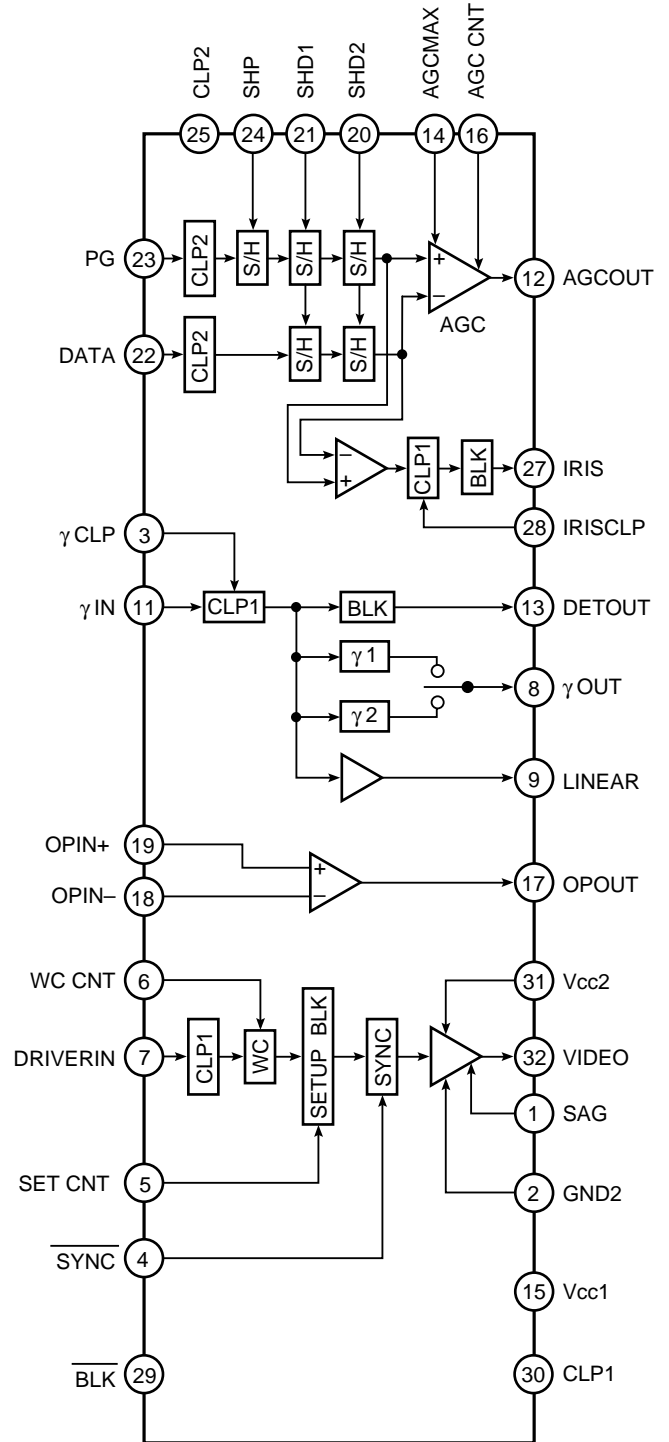

2.2. IC7 on the Power Board is using the Switching Regulator Controller IC YWMB3775PFV.

Description of this IC is as follows:

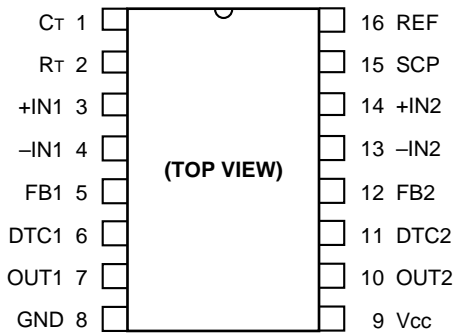

Pin	Name	I/O	Description
1	CT	-	Timing capacitor connecting terminal.
2	R _T	-	Timing resistor connecting terminal.
3	+IN1	I	Non-inverted signal input terminal for Error Amplifier 1.
4	-IN1	I	Inverted signal input terminal for Error Amplifier 1.
5	FB1	-	Feedback terminal for Error Amplifier 1.
6	DTC1	I	Dead Time Control signal input terminal.
7	OUT1	O	Control signal output terminal 1.
8	GND	-	Ground terminal.
9	V _{CC}	-	Power supply terminal.
10	OUT2	O	Control signal output terminal 2.
11	DTC2	I	Dead Time Control signal input terminal.
12	FB2	-	Feedback terminal for Error Amplifier 2.
13	-IN2	I	Inverted signal input terminal for Error Amplifier 2.
14	+IN2	I	Non-inverted signal input terminal for Error Amplifier 2.
15	SCP	-	Short Circuit Protection terminal.
16	REF	O	Reference voltage output terminal.

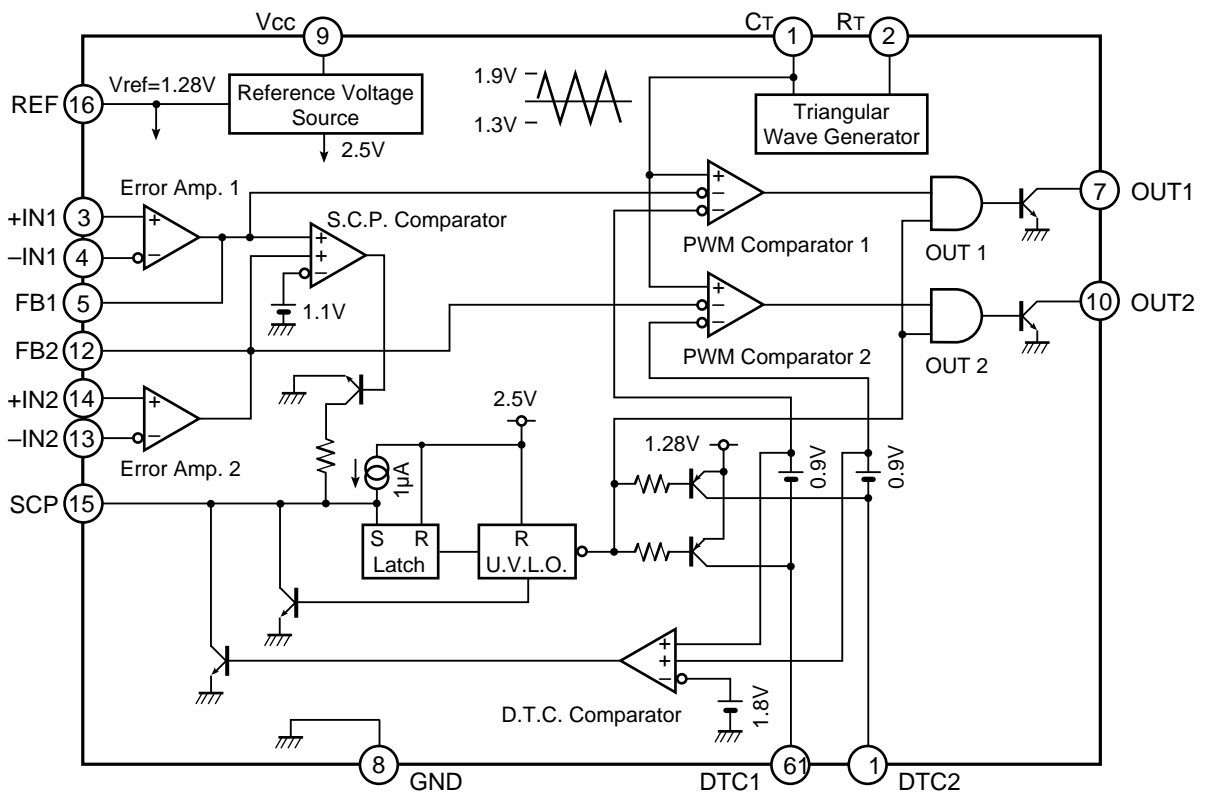

ADJUSTMENT PROCEDURE

1. Test Equipments Required

- The following equipments are required for adjustment of the Industrial Camera GP-MF802.
- Oscilloscope
- Digital Voltmeter
- Camera Cable (GP-CA81, GP-CA82 or GP-CA83)
- Manual Iris Lens
- DC Power Supply Unit
- Underscanned Black & White Video Monitor
- HD/VD Signal Generator or Special Effects Generator
- Lighting (2,750 ± 150 lx (1,050 ± 50 nt))
- 40-watt Lamp
- Illuminometer
- Logarithmic Gray Scale Chart (Part No. : YWV2310RB99) as shown in Fig. 1-1.

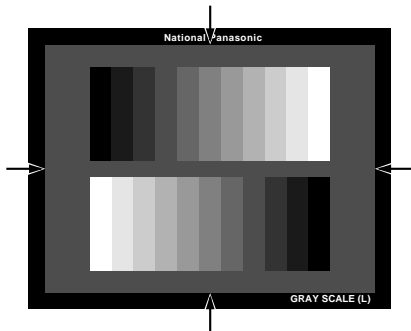

Fig. 1-1

2. Disassembling Procedures for Adjustment

- Referring to Fig. 2-1, remove six screws that secure the Upper Cover and remove the Upper Cover.

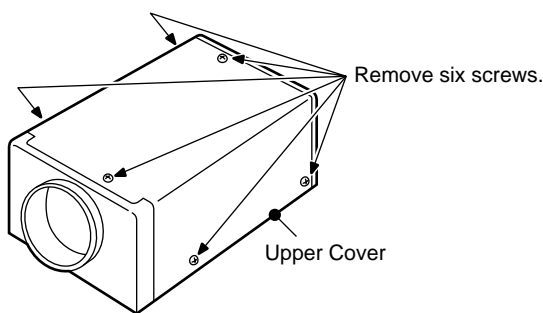

Fig. 2-1

- Referring to Fig. 2-2, remove two screws that secure the Drive Board and remove the Drive Board.

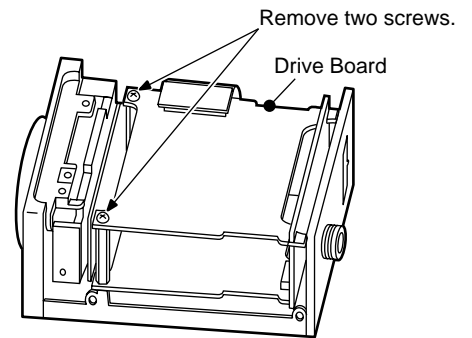

Fig. 2-2

- Referring to Fig. 2-3, remove two hexagon studs that secure the Power Board and remove the Power Board.

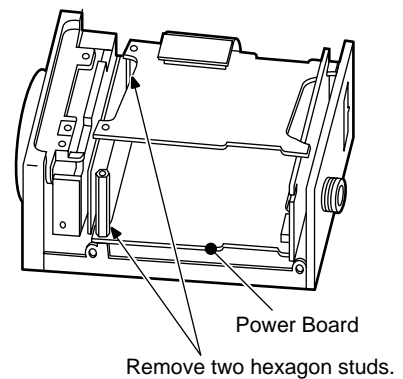

Fig. 2-3

- Referring to Fig. 2-4, remove two screws that secure the Rear Panel and remove the Rear Panel.

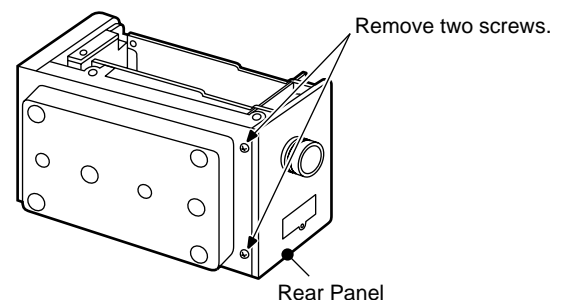

Fig. 2-4

3. Replacement Procedures of the Head Optical Ass'y

- Referring to the item **2. Disassembling Procedures for Adjustment**, remove both the Drive Board and Power Board.
- Referring to Fig. 3-1, remove two screws that secure the Head Optical Ass'y and remove the Head Optical Ass'y.

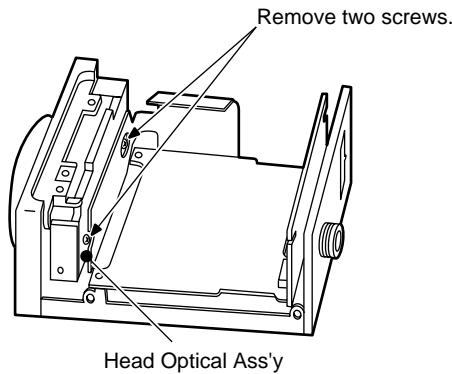

Fig. 3-1

4. Connection and Setting Up for Adjustment

4.1. Connection

- The Fig. 4-1 shows the connecting diagram for the adjustment procedure.

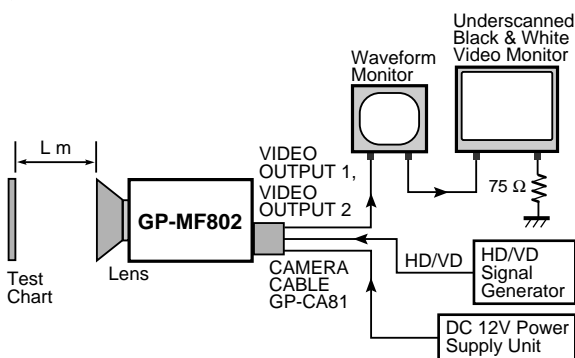

Fig. 4-1

- Connect the Camera Cable GP-CA81 to the Camera Cable Connector on the Rear Panel of the GP-MF802.
- Connect the Underscanned Black and White Video Monitor to the Video Output Connector of the Camera Cable GP-CA81.
- Terminate the input terminal of the Underscanned Black and White Video Monitor with 75Ω.

- Connect the DC 12V Power Supply Unit to the DC 12V Input Cable of the Camera Cable GP-CA81.
Note: Refer to the pin arrangement of the Camera Cable described in the Cameras Cable Connector on the page 1.
- Connect the HD/VD Signal Generator to the HD signal Input Cable and the VD signal Input Cable of the Camera Cable GP-CA81.
- Connect the probe of the Digital Voltmeter or Oscilloscope to the desired Test Point in each adjustment step.

4.2. Setting Up of Switches for Adjustment

- Referring to the Item **3. Switch Cover Removal** of the **PREPARATIONS** in the page 3, remove the Switch Cover.
- Set the Switches on the Rear Panel of the GP-MF802 as follows:

SW1 (Mode 1)OFF position
SW2 (Mode 2)OFF position
SW3 (Shutter Trigger)OFF position
SW4 (Shutter Speed D0)OFF position
SW5 (Shutter Speed D1)OFF position
SW6 (Shutter Speed D2)OFF position
SW7 (HD Termination)ON position
SW8 (VD Termination)ON position
SW9 (Long Time Exposure Mode)OFF position
SW10 (Clock Out)OFF position

- The adjustment should be done with this Setting unless otherwise specified.

4.3. Setting Up for Standard Picture

- Mount the Manual Iris Lens (HF16A) on the Camera.
- Set the Logarithmic Gray Scale Chart.
- Incident light of $1,050 \pm 50$ nt ($2,750 \pm 150$ lx) on the Logarithmic Gray Scale Chart.
- Aim the Camera at the Logarithmic Gray Scale Chart.
- Mount the ND8 Filter on the Lens.
- Set the Camera so that the Logarithmic Gray Scale Chart becomes full picture on the Underscanned Black and White Video Monitor.

- Connect the Oscilloscope to TP1 on the Sensor Board.
- Adjust the Lens Iris so that the CCD output signal at TP1 becomes 214 mV as shown in Fig. 4-2.

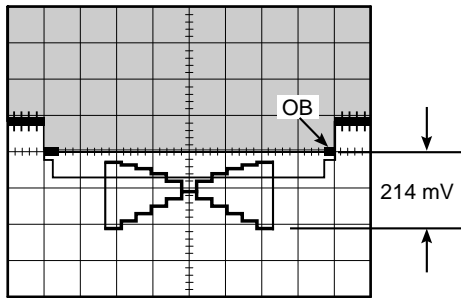

Fig. 4-2

- The adjustment should be done with this Standard Picture unless otherwise specified.

5. Adjustment Procedure

- Refer to the Location of the Test Points and Adjusting Controls on page 15.

(1). PLL VCO Adjustment

Test Point: TP4 (VCO) Drive Board
Adjust: L1 (VCO) Drive Board

- Supply the HD signal and the VD signal from the Camera Cable Connector.
- Connect the Digital Voltmeter to TP4.
- Adjust L1 to obtain 2.2 ± 0.2 V DC.

(2). Reset Bias Adjustment

Test Point: TP1 (CCD OUT 1) Sensor Board
 TP1 (R-BIAS) Drive Board
Adjust: VR1 (R-BIAS) Drive Board

- Aim the Camera at the Logarithmic Gray Scale Chart.
- Connect the Oscilloscope to TP1 on the Sensor Board.
- Trigger the Oscilloscope at the H-rate.
- Adjust VR1 so that the Reset Noise becomes maximum as shown in Fig. 5-1.

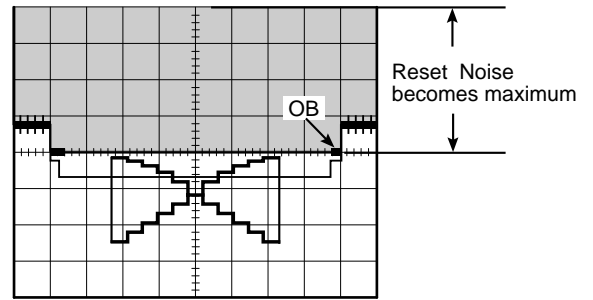

Fig. 5-1

- Connect the Oscilloscope to TP1 on the Drive Board.
- Adjust VR1 so that the Reset Bias becomes 5.0 ± 0.5 V as shown in Fig. 5-2.

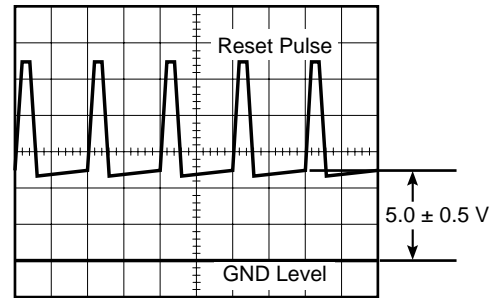

Fig. 5-2

(3). Vsub Coarse Adjustment

Test Point: TP1 (CCD OUT 1) Sensor Board
 TP2 (CCD OUT 2) Sensor Board
Adjust: VR6 (Vsub1) Drive Board
 VR7 (Vsub2) Drive Board

Observe Video Monitor

- Set the Bright Control of the Video Monitor to the mechanical center position.
- Set the Contrast Control of the Video Monitor to the mechanical center position.
- Set the Lens Iris to F8.
- Turn VR7 to obtain noise on the Video Monitor, and adjust VR7 so that the noise just disappears as shown in Fig. 5-3.
- Set the Switch 1 to ON position, and confirm that the no noise appears on the Video Monitor.
- Set the Switch 1 to OFF position.
- Set the Lens Iris to F11.
- Set the Switch 2 to ON position.

- Turn VR6 to obtain noise on the Video Monitor, and adjust VR6 so that the noise just disappears as shown in Fig. 5-3.

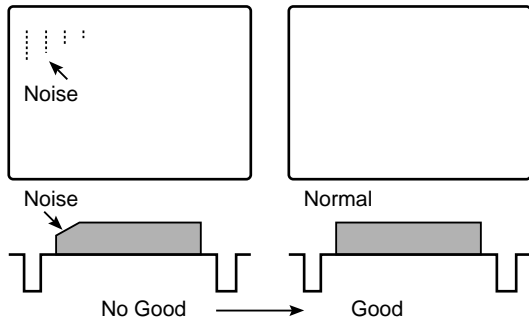

Fig. 5-3

- Set the Switch 2 to OFF position.
- Aim the Camera at the Logarithmic Gray Scale Chart.
- Connect the Oscilloscope to TP1 on the Sensor Board.
- Open the Lens Iris so that only 11th portion of the CCD OUT signal saturates, and confirm that the saturated signal level is more than 400 mV as shown in Fig. 5-4.
- Change the connection of the Oscilloscope to TP2 on the Sensor Board.
- Confirm that the saturated signal level is more than 400 mV as shown in Fig. 5-4, if not satisfied readjust VR7.
- Set the Switch 1 to ON position.
- Confirm that the saturated signal level is more than 400 mV as shown in Fig. 5-4.
- Set the Switch 1 to OFF position.
- Set the Switch 2 to ON position.
- Connect the Oscilloscope to TP1 on the Sensor Board.
- Open the Lens Iris so that only 11th portion of the CCD OUT signal saturates, and confirm that the saturated signal level is more than 400 mV as shown in Fig. 5-4, if not readjust VR6.

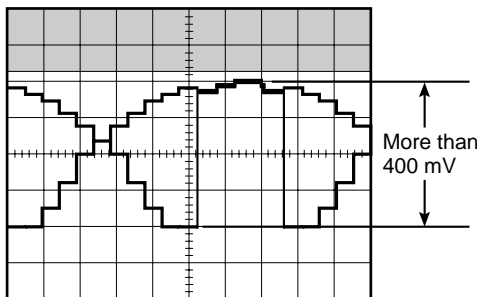

Fig. 5-4

(4). Pedestal-1 and Video Gain-1 Adjustment

Test Point: Video 1

**Adjust: VR2 (GAIN 1)
VR3 (PED 1)**

**Drive Board
Drive Board**

- Cap on the Lens.
- Connect the terminated Oscilloscope with 75Ω to Video 1 of the Camera Cable.
- Set the Switch 1 and Switch 2 to OFF position.
- Adjust VR3 so that the Pedestal signal level becomes 50 ± 10 mV as shown in Fig. 5-5.

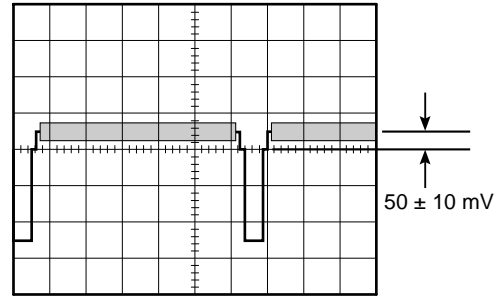

Fig. 5-5

- Remove the Cap from the Lens, and connect the Oscilloscope to TP1 on the Sensor Board.
- Adjust the Lens Iris so that the CCD output signal at TP1 becomes 214 mV.
- Adjust VR2 so that the Video signal level becomes 100 IRE (714 mV) as shown in Fig.5-6, and confirm that the Sync signal level is 40 ± 4.2 IRE (286 ± 30 mV) as shown in Fig. 5-6.

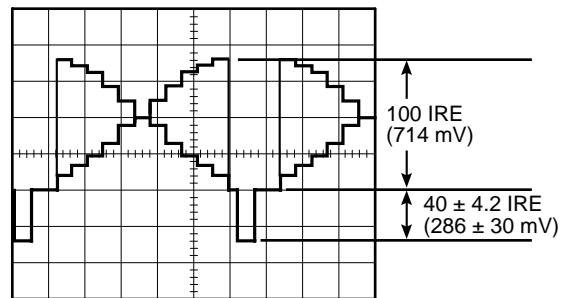

Fig. 5-6

- Set the Switch 1 to ON position.
- Confirm that both Pedestal signal level and Video signal level are within specification.
- Set the Switch 1 to OFF position.

(5). Pedestal-2 and Video Gain-2 Adjustment

Test Point: Video 2

**Adjust: VR4 (PED 2)
VR5 (GAIN 2)**

**Drive Board
Drive Board**

- Aim the Camera at the Logarithmic Gray Scale Chart.

- Connect the terminated Oscilloscope with 75Ω to Video 2 of the Camera Cable.
- Set the Switch 1 and Switch 2 to OFF position.
- Adjust VR4 so that the Pedestal signal level becomes same as that of the Video 1 as shown in Fig. 5-7.

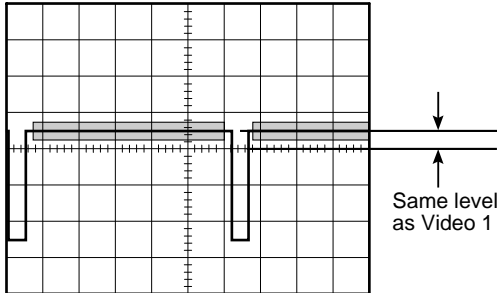

Fig. 5-7

- Remove the Cap from the Lens, and connect the Oscilloscope to TP1 on the Sensor Board.
- Adjust the Lens Iris so that the CCD output signal at TP1 becomes 214 mV.
- Adjust VR5 so that the Video signal level becomes 100 IRE (714 mV) as shown in Fig.5-8, and confirm that the Sync signal level is 40 ± 4.2 IRE (286 ± 30 mV) as shown in Fig. 5-8.

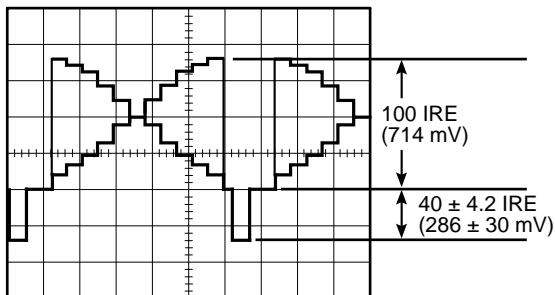

Fig. 5-8

- Set the Switch 1 to ON position.
- Confirm that both Pedestal signal level and Video signal level are within specification.
- Set the Switch 1 to OFF position.

(6). Vsub Fine Adjustment

Adjust: VR6 (Vsub1) Drive Board
VR7 (Vsub2) Drive Board

Observe Video Monitor

- Aim the Camera at the 40-watt Lamp placed in the dark background.
- Set the Lens Iris fully open (F1.4).
- If the blooming and noise appear on the Video Monitor as shown in Fig. 5-9, readjust VR7.

Notes: VR7 should be adjusted to the point where the blooming just eliminates.
Do not turn VR7 too much.
If readjust VR7, must be readjusted from the adjustment steps (3) through (5).

- Set the Switch 1 to ON position, and confirm that the no blooming appears on the Video Monitor.
- Set the Switch 1 to OFF position.
- Set the Switch 2 to ON position.
- If the blooming and noise appear on the Video Monitor as shown in Fig. 5-9, readjust VR6.

Notes: VR6 should be adjusted to the point where the blooming just eliminates.
Do not turn VR6 too much.
If readjust VR6, must be readjusted from the adjustment steps (3) through (5).

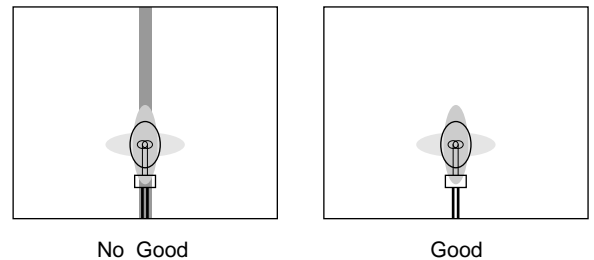
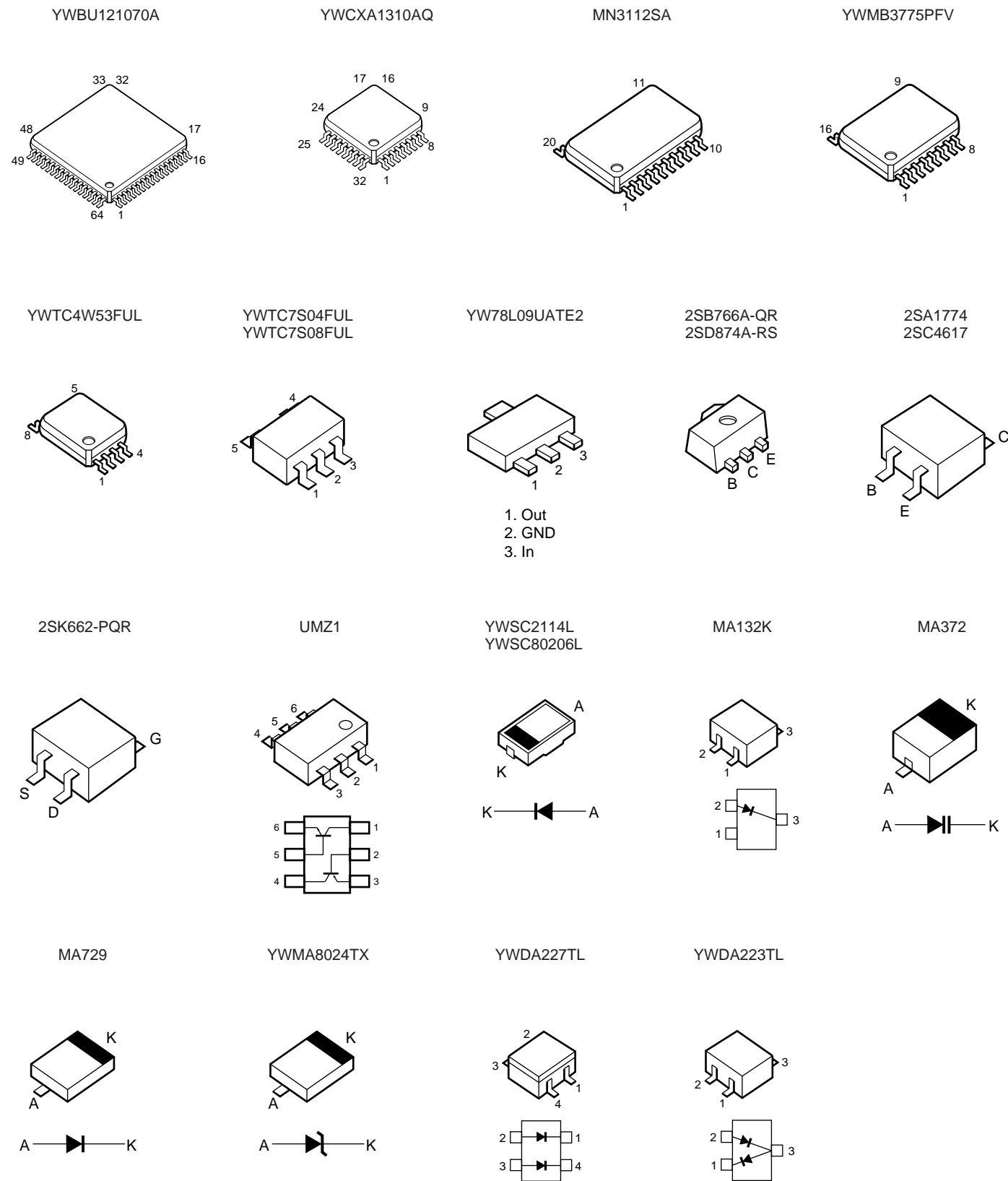

Fig. 5-9

APPEARANCE OF ICs, TRANSISTORS AND DIODES



LOCATION OF TEST POINTS AND ADJUSTING CONTROLS

Drive Board (Component Side)

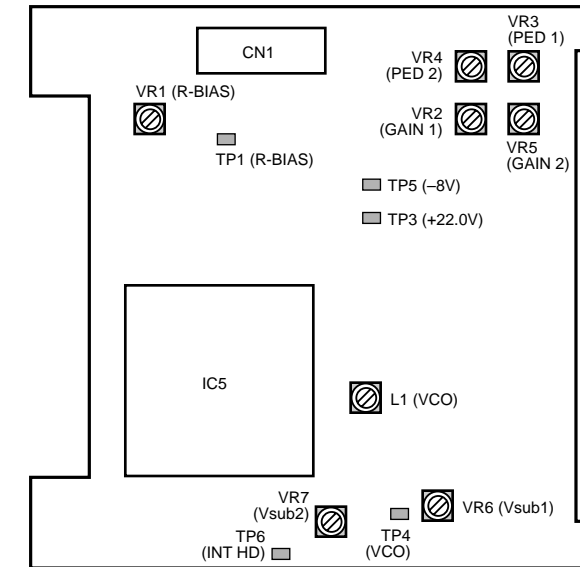

Power Board (Component Side)

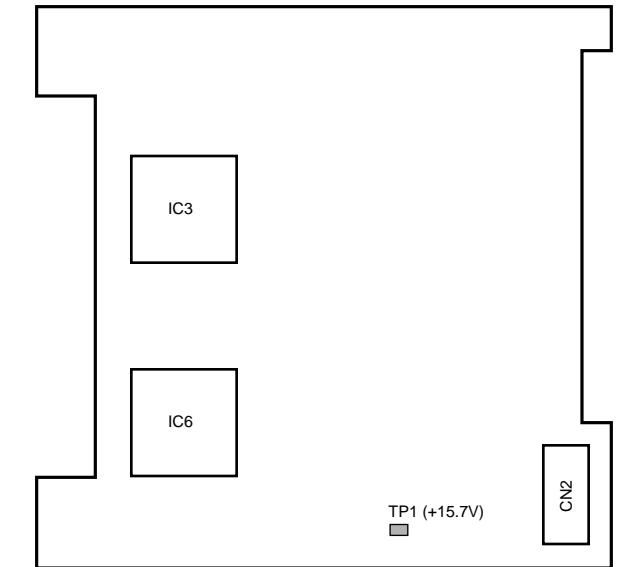

Sensor Board (Component Side)

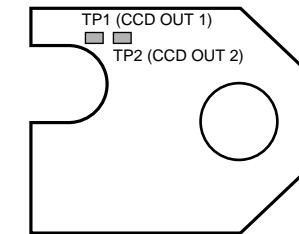

Rear Panel

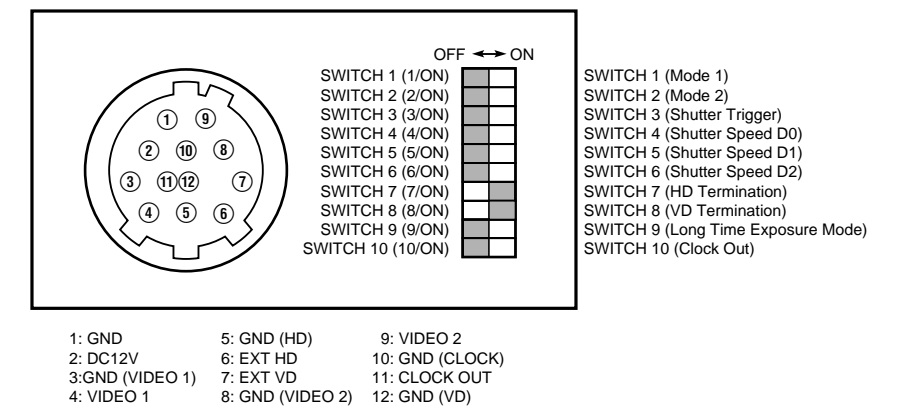

CHIP COMPONENTS

1. Chip Transistor

The transistor number is indicated on the top surface of the chip transistor using two alphabet letters or one numerical number and two alphabet letters.

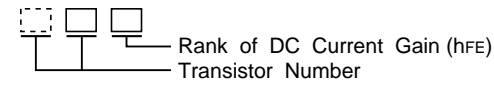

Transistor Number

(Chip Transistor)

Letter	Transistor No.	Letter	Transistor No.
A	2SB709	X	2SD602A
B	2SB709A	Y	2SD601
C	2SB710	Z	2SD601A
D	2SB710A	1A	2SB799
E	2SA1022	1B	2SB814
F	2SA1034	1C	2SB902
H	2SA1035	1F	2SK321
I	2SB792	1K	2SK316
K	2SC2778	1L	2SK247
P	2SD814	1M	2SJ84
Q	2SD813	1N	2SK199
R	2SC2480	1O	2SK198
S	2SC2405	1T	2SC3077
T	2SC2406	1X	2SC2845
U	2SC2404	1Z	2SD1030
V	2SC2295	2B	2SK374
W	2SD602	2C	2SK116
BQ	2SB766A	UMT	2SC4081

(Small Chip Transistor) (Pair Transistor)

Letter	Transistor No.	Letter	Transistor No.	Letter	Transistor No.
A	2SB1218	5R	XN1501	5H	XP4501
B	2SB1218A	7S	XN1601	5C	XP4601
D	2SB1219A	5H	XN4501	5H	XP4501
U	2SC3931	5C	XN4601	5L	XP5501
W	2SD1820	5L	XN5501	4N	XP5601
X	2SD1820A	4N	XN5601	7S	XP6501
Y	2SD1819	5N	XN6501	7W	XP6435
E3	2SA1226	7W	XN6435	7F	XP6534
OS	2SB1219	7F	XN6534	X1	UMX1
UC	2SA1532	5R	XP1501	Z1	UMZ1
YU	2SC3938	7S	XP1601		

Example: WQ → 2SD602-Q
 YQ → 2SD601-Q
 1BS → 2SB814-S

Appearance and Symbols

Transistor

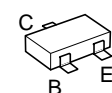

C: Collector
 B: Base
 E: Emitter

FET

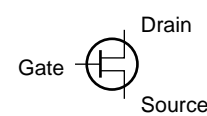
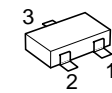

	1	2	3
Except 2SK199	Drain	Source	Gate
2SK199	Gate	Drain	Source

2. Chip Diode

The diode number is indicated on the top surface of the chip diode using two alphabet letters.

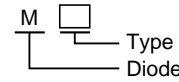

Diode Number

Letter	Diode No.	Letter	Diode No.
MA	MA151A	MI	MA152K
MB	MA152A	MK	MA28W-B
MC	MA153	ML	MA28T-A
MD	MA28-A	MN	MA151WA
ME	MA28-B	MO	MA152WA
MF	MA28W-A	MT	MA151WK
MH	MA151K	MU	MA152WK
MH	MA141K	6.2	MA3062
MC	MA143	SMD	RD421D

Appearance and Symbol

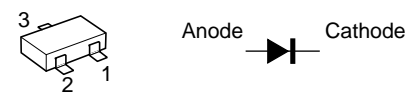

	1	2	3
MA28/MA28W/MA28T	-	Anode	Cathode
MA151K/MA152K	-	Anode	Cathode
MA151A/MA152A	-	Cathode	Anode
MA151WK/MA152WK	Anode	Anode	Cathode
MA151WA/MA152WA	Cathode	Cathode	Anode
MA153	Cathode	Anode	Common
MA141K	-	Anode	Cathode
MA143	Anode	Cathode	Common
MA3062	Anode	-	Cathode
RD421D	Anode	-	Cathode

3. Chip Resistor

The resistor value is indicated on the bottom surface of the chip resistor using three digit numbers.

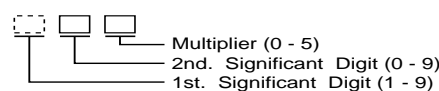

Example: 330 → 33 x 10⁰ = 33 Ω
 561 → 56 x 10¹ = 560 Ω
 123 → 12 x 10⁻³ = 12 kΩ

Note: Zero ohm resistor (jumper chip) is colored red or green.

4. Chip Capacitor

The capacitive value of replacement chip capacitors is indicated on the bottom surface. Original parts have no value indication.

If the capacitive value is less than 100 pF, the value will be indicated by one or two digit number expressing the capacity directly in pF.

Example:

0.5 → 0.5 pF 2.5 → 2.5 pF
 .75 → 0.75 pF 33 → 33 pF
 1 → 1 pF 82 → 82 pF

If the capacitive value is 100 pF or greater, the value will be indicated by an alpha-numeric code. The letter precedes the number and expresses a numerical value to be multiplied by the number which follows.

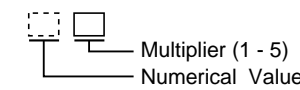

Numerical Value

Letter	Value	Letter	Value
A	10	N	33
B	11	P	36
C	12	Q	39
D	13	R	43
E	15	S	47
F	16	T	51
G	18	U	56
H	20	V	62
J	22	W	68
K	24	X	75
L	27	Y	82
M	30	Z	91

* Letters I and O are not used.

Example: A1 → 10 x 10¹ = 100 pF
 N2 → 33 x 10² = 3300 pF
 S3 → 47 x 10³ = 47000 pF

5. Precautions in replacing the chip component

1. Make sure that the unit is turned OFF when replacing the chip.
2. Use tweezers to prevent any damage to the chip surface.
3. Do not re-use the chips after removal.
4. Do not rub the electrode of chips.
5. Do not subject the chips to excessive stress.
6. It is recommended that a pencil-type soldering iron to be used.
7. The solder whose diameter is less than 0.5 mm is recommended.
8. Do not heat the chip more than 3 seconds.
9. Maintain temperature control under 260°C (500°F) when soldering.

5-1. Removal (Transistor, Diode, Resistor and Capacitor)

1. Add the solder to both ends of the chip (three leads for chip transistor).
2. While attaching the soldering iron to both ends of the chip (three leads for chip transistor) as shown below, remove the chip by turning with tweezers.

Note: Be careful not to damage other chips.

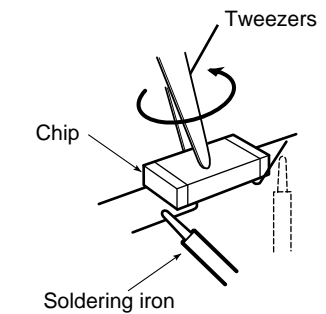

5-2. Removal (IC)

1. Add the solder wick and soldering iron to each lead of the IC and remove solder.

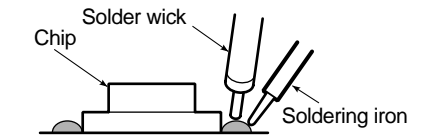

2. Add the soldering iron to each lead of the IC and left each lead of the IC using thinner pin.

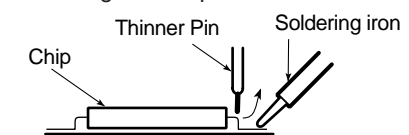

3. Remove the IC turning with pliers.

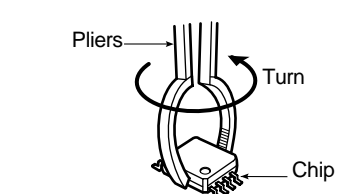

5-3. Mounting

1. Place the solder thinly on the chip mounting foil.
2. Solder the chip temporarily while holding the chip with the tweezers.

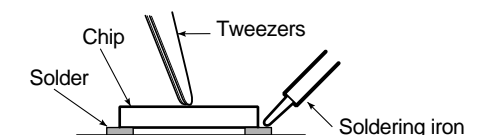

3. Solder both ends of the chip (three leads for chip transistor).

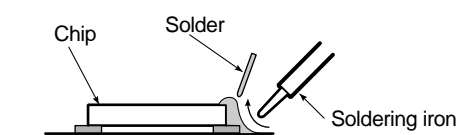

BLOCK DIAGRAM

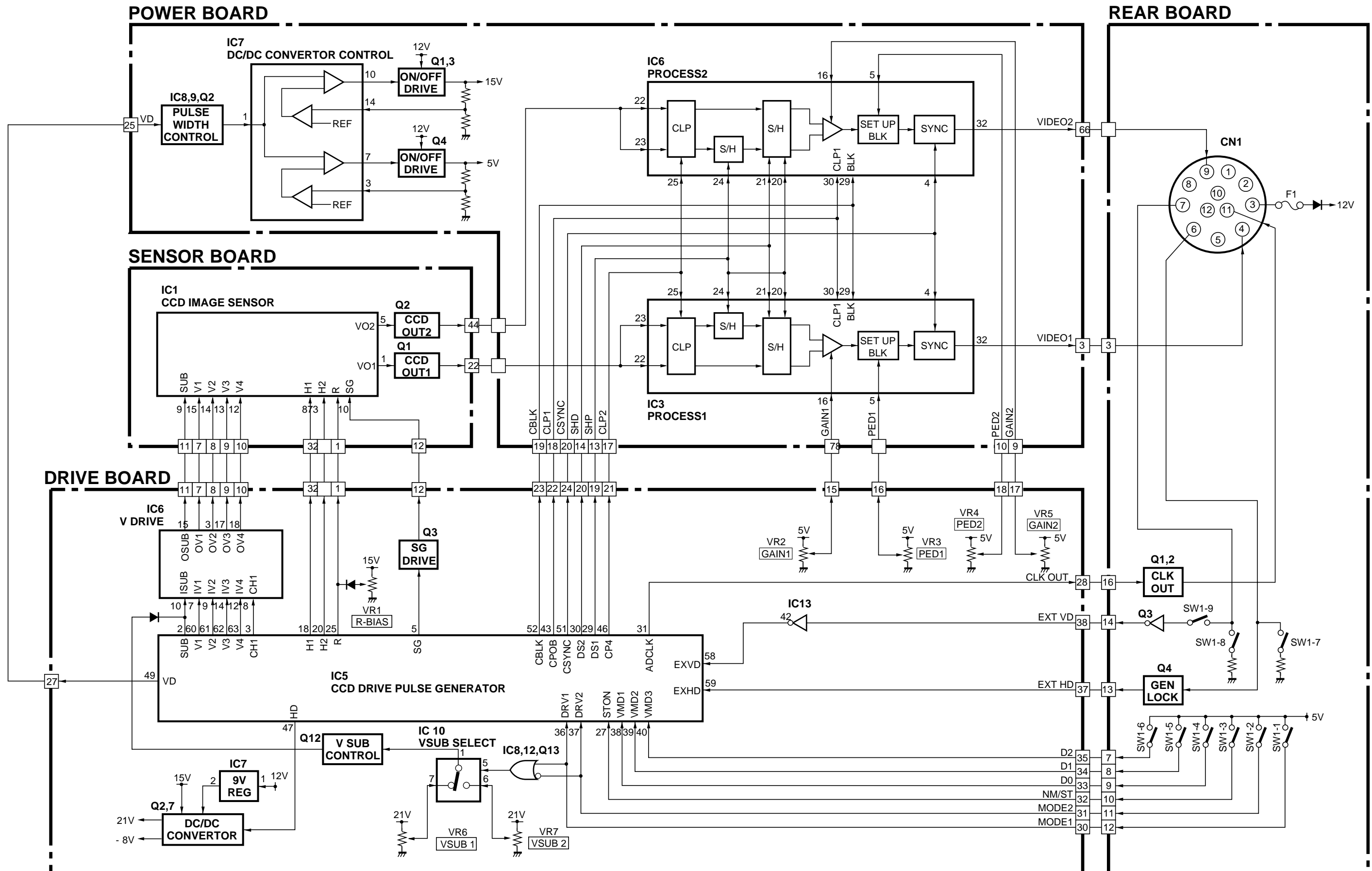

EXPLODED VIEW

○ Numbers show screws, washers and etc.

No.	Screws	Description
①	XSS2+4FXK	Flush Head Black Screws
②	XYN2+J5FN	Machine Screw and Washer Assy
③	XSB2+8FXK	Binding Head Black Screws
④	XYN2+F8FN	Machine Screw and Washer Assy
⑤	XSB2+4FXK	Binding Head Black Screws
⑥	XWE2FN	Small Round Plain Washer

