

## VACUUM FLUORESCENT DISPLAY MODULE

### ENGINEERING PROPOSAL

GP1202B02C

EVALUATION

- ACCEPTED WITHOUT ANY CHANGE  
 THE FOLLOWING CHANGE IS REQUIRED

JULY 17, 2013

Engineering Group

Technical Center

Electronic Components Division

## Futaba Corporation

ISSUED BY

Takeyuki Fujimoto

CHECKED BY

Toshikazu Hishioaka

CHECKED BY

Masaru Yabuyama

APPROVED BY

Katsunori Kase

## Important Safety Notice

Please read this note carefully before using the product.

### Warning

- The module should be disconnected from the power supply before handling.
- The power supply should be switched off before connecting or disconnecting the power or interface cables.
- The module contains electronic components that generate high voltages (approx. 59 V) which may cause an electrical shock when touched.
- Do not touch the electronic components of the module with any metal objects.
- The VFD used on the module is made of glass and should be handled with care. When handling the VFD, it is recommended that cotton gloves be used.
- The module is equipped with a circuit protection fuse.
- Under no circumstances should the module be modified or repaired. Any unauthorized modifications or repairs will invalidate the product warranty.
- The module should be abolished as the factory waste.

## 1. Summary

1-1. This vacuum fluorescent display (VFD) module consists of a 160×64 number of pixels, 0.4×0.4 pitch dot matrix display.

1-2. This module supports USB2.0 HID communication interface.

1-3. Since a DC-DC/AC converter is equipped, only 5Vdc power source is required to operate the module.

1-4. The module includes flash ROM for international font, Simplified Chinese, Traditional Chinese, Japanese, and Korean can be displayed.

## 2. General Specification

### 2-1. DIMENSIONS, WEIGHT (Refer to FIGURE-1)

Table-1

Item	Specification	Unit
Outer Dimensions	Length 110.0±1	mm
	Width 47.0±1	
	Thickness 22.4	
Weight	Approx. 70	g

### 2-2. SPECIFICATION OF THE DISPLAY PANEL

Table-2

Item	Specification	Unit
Display area dimension	63.9(row)×25.5(column)	mm
Display content	160(row)×64(column)	Dot
Dot size	0.3(row)×0.3(column)	mm
Dot pitch	0.4(row)×0.4(column)	mm
Color illumination	Green ( $\lambda_p=505\text{nm}$ )	—

### 2-3. ENVIRONMENT CONDITIONS

Table-3

Item	Symbol	Min.	Max.	Unit
Operation Temperature	$T_{opr}$	-40	+85	°C
Storage Temperature	$T_{stg}$	-40	+85	°C
Operation Humidity(Note)	$H_{opr}$	20	85	%
Storage Humidity(Note)	$H_{stg}$	20	90	%
Vibration (10~55Hz)	—	—	4	G
Shock	—	—	40	G

Note) Avoid moist environmental conditions.

### 2-4. ABSOLUTE MAXIMUM ELECTRICAL RATINGS

Table-4

Item	Symbol	Min.	Max.	Unit
Supply Voltage	$V_{cc}$	-0.3	+6.5	Vdc
Input Signal Voltage	$V_{IS}$	-0.3	+3.9	Vdc

## 2-5. RECOMMEND OPERATING CONDITIONS

Table-5

Item	Symbol	Min.	Typ.	Max.	Unit
Supply Voltage	$V_{CC}$	4.5	5.0	5.5	Vdc
H-Level Input Voltage	$V_{IH}$	2.0	—	—	V
L-Level Input Voltage	$V_{IL}$	—	—	0.8	

## 2-6. ELECTRICAL, OPTICAL CHARACTERISTICS UNDER STANDARD OPERATING CONDITIONS

Table-6

Item	Symbol	Condition	Min.	Typ.	Max.	Unit
Supply Current (Note 1)	$I_{CC}$	$V_{CC}=5.0V$ All on	—	570	700	mA
Power Consumption	—		—	2.85	3.5	W
Luminance (Note 2)	$L$		450	900	—	cd/m <sup>2</sup>
H-Level Output Voltage	$V_{OH}$	$V_{CC}=5.0V$	2.8	—	3.6	V
L-Level Output Voltage	$V_{OL}$	$V_{CC}=5.0V$	—	—	0.3	V

Note 1) The surge current can be approx. 5 times the supply current (Max.) at power on.

Note 2) The luminance level is set at 100% luminance value.



The explanation of standard structure.

Table-8

Offset	Field	Description	Size [byte]	Value	Comment
0	bLength	Size of this descriptor in bytes	1	09H	
1	bDescriptorType	CONFIGURATION Descriptor Type	1	02H	
2	wTotalLength	Total length of data returned for this configuration	2	0022H	34 bytes
4	bNumInterfaces	Number of interfaces supported by this configuration	1	01H	
5	bConfigurationValue	Value to use as an argument	1	01H	
6	iConfiguration	Index of string descriptor describing this configuration	1	00H	
7	bmAttributes	Configuration characteristics	1	C0H	Bus powered Disable Remove Wakeup
8	MaxPower	Maximum power consumption	1	FAH	GP1202B02C (700mA)

The explanation of interface.

Table-9

Offset	Field	Description	Size [byte]	Value	Comment
0	bLength	Size of this descriptor in bytes	1	09H	
1	bDescriptorType	INTERFACE Descriptor Type	1	04H	
2	bInterfaceNumber	Number of this interface	1	00H	VFD Control
3	bAlternateSetting	Value used to select this alternate setting	1	00H	
4	bNumEndpoints	Number of endpoints used by this interface	1	01H	
5	bInterfaceClass	Class code	1	03H	HID
6	bInterfaceSubClass	Subclass code	1	00H	
7	bInterfaceProtocol	Protocol code	1	00H	
8	iInterface	Index of string descriptor describing this interface	1	02H	

The explanation of HID.

Table-10

Offset	Field	Description	Size [byte]	Value	Comment
0	bLength	Size of HID descriptor	1	09H	
1	bDescriptorType	HID descriptor type	1	21H	HID Class descriptor
2	bcdHID	HID class specification	2	0110H	HID Revision 1.10
4	bCountry	Country code of the localized hardware	1	00H	Not defined
5	bNumDescriptors	Number of class descriptors	1	01H	1 report descriptor
6	bReportType	Type of class descriptor	1	22H	REPORT descriptor
7	wReportLength	Descriptor length	2	0027H	39 bytes

The explanation of ENDPOINT.

Table-11

Offset	Description	Size [byte]	Value	Comment
0	Size of this descriptor in bytes	1	07H	
1	Endpoint descriptor type	1	05H	
2	The address of the endpoint on the USB device described by this descriptor	1	87H	EP7, IN
3	The endpoint's attributes	1	03H	Interrupt Transfer
4	Maximum packet size this endpoint	2	0008H	
6	Interval for polling endpoint for data transfers	1	04H	4[ms]

The explanation of HID communication

Table-12

Part	Value (HEX)
Usage Page (Vendor-defined),	06 7F FF
Usage (VFD_CONTROL),	09 06
Collection (Application),	A1 01
Usage (VFD_DATA_SIZE),	09 80
Logical Minimum (0),	15 00
Logical Maximum (255),	26 FF 00
Report Size (8),	75 08
Report Count (1),	95 01
Input (Data,Variable,Absolute),	81 02
Usage (VFD_DATA_INPUT),	09 81
Report Count (63),	95 3F
Input (Data,Variable,Absolute),	81 02
Usage (VFD_DATA_SIZE),	09 80
Report Count (1),	95 01
Output(Data,Variable,Absolute),	91 02
Usage (VFD_DATA_OUTPUT),	09 82
Report Count (63),	95 3F
Output(Data,Variable,Absolute),	91 02
End Collection	C0

Table-13

Description	Value (HEX)
VFD_CONTROL	06
VFD_DATA_SIZE	80
VFD_DATA_INPUT	81
VFD_DATA_OUTPUT	82

The explanation of HID communication.

Table-14

No	Part	Description	Value
No.0	bLength	Length	0x04
	bDescriptorType	Type=STRING	0x03
	bSting	LangID (English US)	0x0409
No.1	bLength	Length	0x0E
	bDescriptorType	Type=STRING	0x03
	bSting	Manufacturer	FUTABA
No.2	bLength	Length	0x22
	bDescriptorType	Type=STRING	0x03
	bSting	Product	DISPLAY GP1202B02C/GP1232A01C



### 3-2. Display memory

#### 3-2-1. Memory position and Display Window (DW)

The module has memory area as following. It realizes displaying the Display Window (DW).

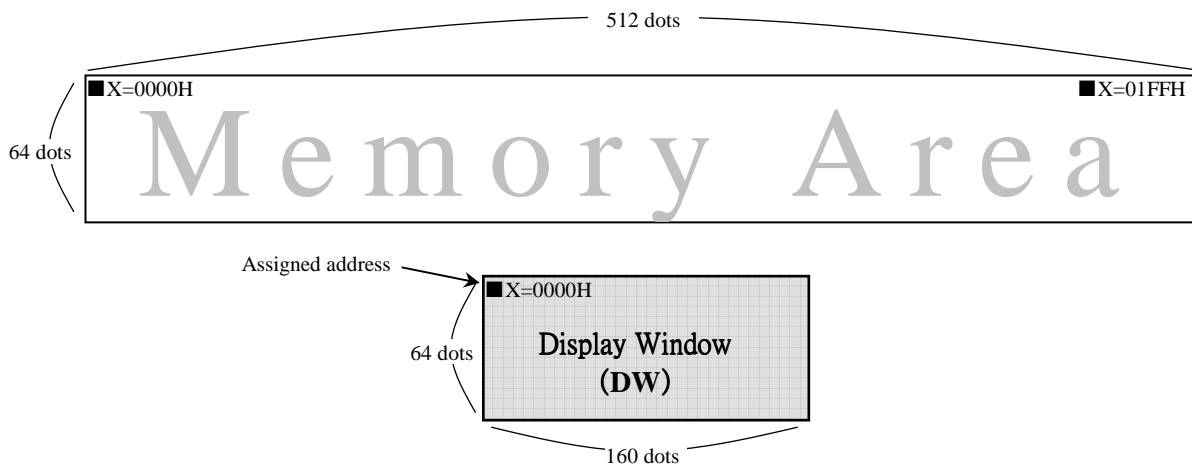

#### 3-2-2. Display Data

To display data, it is needed to write data into the memory and transfer DW to position of write data.

The methods of writing data in memory area are the method of writing text or BMP data write and copying the registered data of FROM.

- If there is already data to write in the address, the new data is overwritten.
- When write in text data, please assign the address of the upper left position of font data.
- After writing text data, the cursor position moves to right by one character size.

3-2-3.Memory address and data

To set address or write data, an address of top left corner dots (8 vertical dots and horizontal dot) should be specified in bytes.

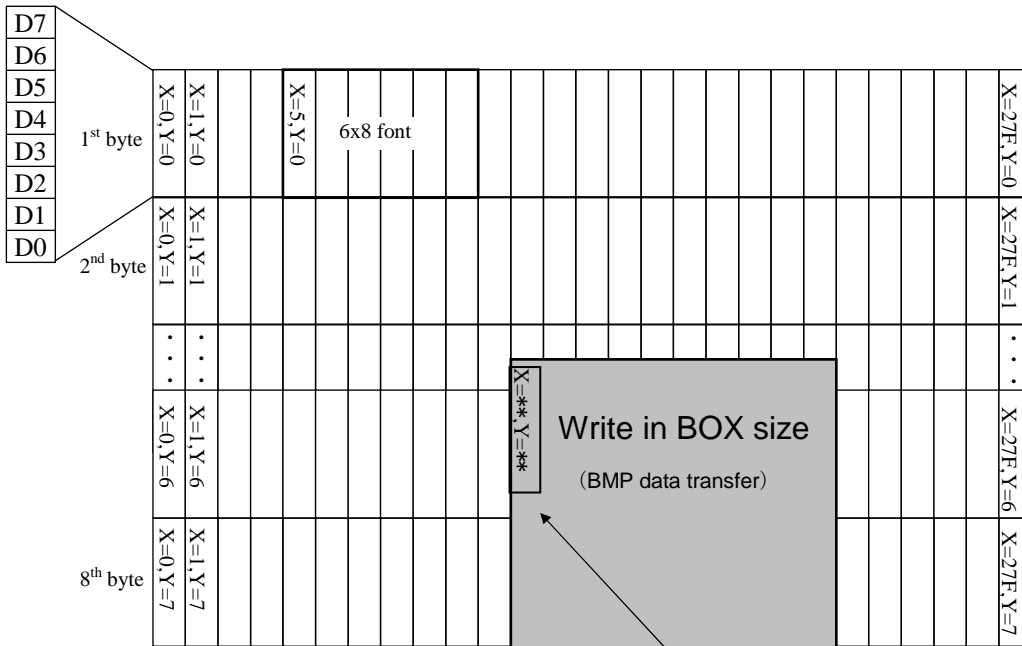

3-2-4. FROM address and data

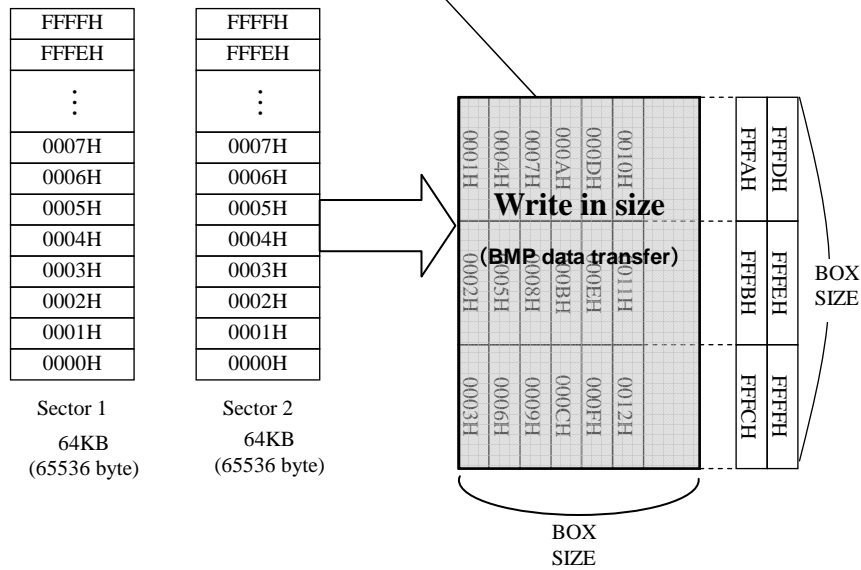

The relation between BMP data registered address and data of FROM as above. The sector has 64KB capacity. Sector 1 and Sector 2 are available.

BMP data definition is performed per 64KB. If the data is less than 64KB, the rest of the memory space will be written in as FFH.

## 4. Command

Following is the command list.

Sort	Command	Byte	1st	2nd	3rd	4th	5th	6th	7th	8th	9th	10th	11th	Default (Power ON)
Basic	Reset	2		0Bh										—
	Memory Clear	2		0Ch										—
	Dimming Set	3		20h	Dimming Set									FFh
	Power ON/OFF	3		21h	Power ON/OFF									PW=1(Power ON)
	Display Position Set	4	1Bh	22h	Position									DSA=0
	Blink Set	4		23h	X Upper Blink Mode	X Lower Blink Time								Bm=0(No blink)
	BMP Write data	9~ Variable		2Eh	X Upper Upper Left Position	X Lower Position	Y		X Upper Size	X Lower Size	Y		Write Data (1~4096 byte)	—
	BMP Data Read	11		2Fh	X Upper Position	X Lower Position	Y		X Upper Size	X Lower Size	Y	Block	Upper Lower	—
	Cursor Position	5		30h	X Upper Language Set	X Lower Language Set	Y							cX=0,cY=0
	Language Set	3	1Bh	32h	Font Size Appointment									La =0(Simplified)
Text Size Set	3		33h	User Definable Font ON/OFF									Ca = 0 (User-Definable Font OFF)	
User Definable Font Set	3		34h										—	
Text	Half-width Text or User Definable Font	1	20h~7Fh											—
	Full-width Text	2	80h~FDh											—
	Full-width User Definable Font	2	FEh											—
	Scroll Box Size Set	8	1Bh	40h	X Upper Upper Left Position	X Lower Upper Left Position	Y		X Upper Size	X Lower Size	Y			sX = 0, sY = 0
	Scroll Speed Set	3		41h	Scroll Speed									S = 0(2 x speed)
	Text Scroll Write	4~ Variable	1Bh	50h	Scroll Text Length				Text Data(1~64byte)					—
Text Scroll	Text Scroll Write Start	2	51h											—
	Switch Of FROM Register Release From FROM Register	2	A0h											—
FROM Register	BMP Data write	Variable		A2h	Block	Upper Lower								—
	User Definable Font Register(16X16 Font)	Variable	1Ah	A3h	Register Text	1 character equals 32 byte(16x2)x Register text(1~16 characters)								—
	User Definable Font Register(8X16 Font)	Variable		A4h	Register Text	1 character equals 17 byte(8x2 + address(1))x Register text(1~16 characters)								—
	User Definable Font Register(6X8 Font)	Variable		A5h	Register Text	1 character equals 7 byte(6x1 + address(1))x Register text(1~16 characters)								—
	FROM Data Clear	2		A7h	Choice									—

## 4-1. Command detail

Following is the details of each command.

Command name : Software Reset

Code : 1Bh,0Bh

Code	Byte	MSB				LSB				Note
		Bit7	Bit6	Bit5	Bit4	Bit3	Bit2	Bit1	Bit0	
1Bh	1st	0	0	0	1	1	0	1	1	
0Bh	2nd	0	0	0	0	1	0	1	1	Software Reset

Function : Following data as initial

Dimming Parameter	: 05h(5/5)
Power ON/OFF	: PW=1(Power ON)
Display position setting	: DSA=0
Blinking mode	: Bm=0(No Blink)
Cursor position	: cX=0,cY=0
Language setting	: La=0(Simplified Chinese)
Font setting	: Fo=0(16×16 Dot Mode)
User definable font setting	: Ga=0( User definable font OFF)
Scroll box position	: pX=0,pY=0
Scroll box size	: sX=0,sY=0
Scroll speed setting	: S=0(double speed)
Scroll text	: 256 byte all clear
Scroll byte	: sL=0(1byte)
Memory	: All 00h

Command name : Memory Map Clear

Code : 1Bh,0Ch

Code	Byte	MSB				LSB				Note
		Bit7	Bit6	Bit5	Bit4	Bit3	Bit2	Bit1	Bit0	
1Bh	1st	0	0	0	1	1	0	1	1	
0Ch	2nd	0	0	0	0	1	1	0	0	Memory Map Clear

Function : Memory Map data all become 0.

Command name : Dimming Set

Code : 1Bh,20h,D

Code	Byte	MSB				LSB				Note
		Bit7	Bit6	Bit5	Bit4	Bit3	Bit2	Bit1	Bit0	
1Bh	1st	0	0	0	1	1	0	1	1	
20h	2nd	0	0	1	0	0	0	0	0	Dimming Setting Command
D	3rd	D7	D6	D5	D4	D3	D2	D1	D0	Dimming

3rd byte	D7	D6	D5	D4	D3	D2	D1	D0	Dimming Value
0	0	0	0	0	0	0	0	0	0% Light Off
0	0	0	0	0	0	0	0	1	25% Dark
0	0	0	0	0	0	0	1	0	50%
0	0	0	0	0	0	0	1	1	75%
0	0	0	0	0	0	1	0	0	100% Bright(Initial)

Function : Set value of VFD dimming (brightness) .

Command name : VFD Power ON/OFF

Code : 1Bh,21h,PW

Code	Byte	MSB					LSB				Note
		Bit7	Bit6	Bit5	Bit4	Bit3	Bit2	Bit1	Bit0		
1Bh	1st	0	0	0	1	1	0	1	1		
21h	2nd	0	0	1	0	0	0	0	1	Power setting command	
PW	3rd	*	*	*	*	*	*	*	PW	Power ON/OFF	

Function : VFD power ON/OFF controller command. If PW=0, VFD power is OFF, if PW=1, VFD power is ON.

- The state of display power ON/OFF is valid until next command of power or soft reset.

Command name : Display position Set

Code : 1Bh,22h,DSA

Code	Byte	MSB					LSB				Note
		Bit7	Bit6	Bit5	Bit4	Bit3	Bit2	Bit1	Bit0		
1Bh	1st	0	0	0	1	1	0	1	1		
22h	2nd	0	0	1	0	0	0	1	0	Display position set	
DSA	3rd	*	*	*	*	*	*	*	DSA8		
	4th	DSA7	DSA6	DSA5	DSA4	DSA3	DSA2	DSA1	DSA0		

Function : Set display position of memory area.

- Display starting position : Set (DSA[8..0]) as leftmost of display position.

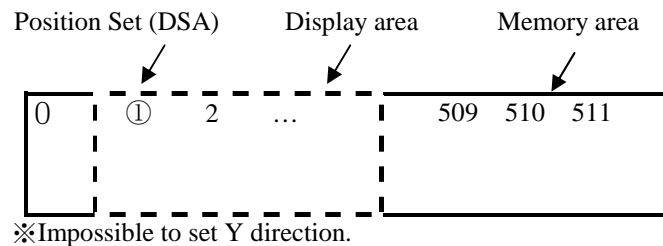

Command name : Blink Set

Code : 1Bh,23h,BM,Bt

Code	Byte	MSB					LSB				Note
		Bit7	Bit6	Bit5	Bit4	Bit3	Bit2	Bit1	Bit0		
1Bh	1st	0	0	0	1	1	0	1	1		
23h	2nd	0	0	1	0	0	0	1	1	Blink setting command	
BM	3rd	*	*	*	*	*	*	BM1	BM0	Blink mode	
Bt	4th	Bt7	Bt6	Bt5	Bt4	Bt3	Bt2	Bt1	Bt0	Blanking time	

3rd byte	BM1	BM0	Blink Mode
	0	0	No Blink
	0	1	ON/OFF invert Blink
	0	*	All OFF/Display Blink

Function : Control display blink(ON/OFF).

- Set blink pattern by blink mode(BM[2..0]).
- Display switch by (Bt[7..0]+1) × approx. 500ms.
- The condition is valid until next Blink Set, software Reset or hardware Power OFF.

Command name : BMP data Write  
 Code : 1Bh,2Eh,pX,pY,sX,sY,Date

Code	Byte	MSB					LSB			Note
		Bit7	Bit6	Bit5	Bit4	Bit3	Bit2	Bit1	Bit0	
1Bh	1st	0	0	0	1	1	0	1	1	
2Eh	2nd	0	0	1	0	1	1	1	0	BMP data Write command
pX	3rd	*	*	*	*	*	*	*	pX8	Write start position left-side
	4th	pX7	pX6	pX5	pX4	pX3	pX2	pX1	pX0	
pY	5th	*	*	*	*	*	pY2	pY1	pY0	Write start position up-side
sX	6th	*	*	*	*	*	*	*	sX8	Width of Write size
	7th	sX7	sX6	sX5	sX4	sX3	sX2	sX1	sX0	
sY	8th	*	*	*	*	*	sY2	sY1	sY0	Height of Write size
Data	9th ~									Write data (sX+1)×(sY+1) byte

3rd / 4th byte

pX8	pX7	pX6	pX5	pX4	pX3	pX2	pX1	pX0	Start write on left position
0	0	0	0	0	0	0	0	0	0
0	0	0	0	0	0	0	0	1	1
0	0	0	0	0	0	0	1	0	2
:									:
1	1	1	1	1	1	1	1	0	510
1	1	1	1	1	1	1	1	1	511

5th byte

pY2	pY1	pY0	Start write on top position
0	0	0	address position0
0	0	1	address position 1
0	1	0	address position 2
:			:
1	1	0	address position 6
1	1	1	address position 7

6th / 7th byte

sX8	sX7	sX6	sX5	sX4	sX3	sX2	sX1	sX0	Width of Write size
0	0	0	0	0	0	0	0	0	1 dot
0	0	0	0	0	0	0	0	1	2 dot
0	0	0	0	0	0	0	1	1	3 dot
:									:
1	1	1	1	1	1	1	1	0	511 dot
1	1	1	1	1	1	1	1	1	512 dot

8th byte

sY2	sY1	sY0	Height of Write size
0	0	0	8 dot
0	0	1	16 dot
0	1	0	24 dot
:			:
1	1	0	56 dot
1	1	1	64 dot

Function : BMP data is written at memory area.

- Write data is written vertically from write start position (pX[8..0]\_pY[2..0]). After writing height size (sY[2..0]), the write position shifts to a line on the right.
- The command is completed after writing data horizontally amount of write width size (sX[8..0]).
- If write area is over the memory area of the right side(pX=511), the write position is displaced to memory area left end (pX=0) after write until memory area right end (pX=1023).
- When writing area is over the memory area of the below side (pY=7),the write position is displaced to memory top (pY=0) after write until memory area lower end (pY=7).
- If font size is 8x16, it is no display when write data in seventh row (Y=7).

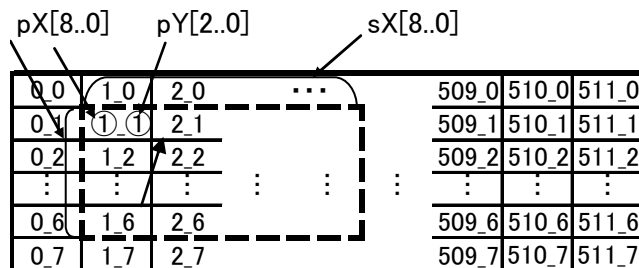

Command name : BMP data Read  
 Code : 1Bh,2Fh,pX,sX,sY,B,Fr

MSB					LSB						
Code	Byte	Bit7	Bit6	Bit5	Bit4	Bit3	Bit2	Bit1	Bit0	Note	
1Bh	1st	0	0	0	1	1	0	1	1		
2Fh	2nd	0	0	1	0	1	1	1	1	BMP data Read command	
pX	3rd	*	*	*	*	*	*	*	pX8	Start write on left position	
	4th	pX7	pX6	pX5	pX4	pX3	pX2	pX1	pX0		
pY	5th	*	*	*	*	*	*	pY2	pY1	pY0	Start write on top position
sX	6th	*	*	*	*	*	*	*	*	sX8	Width of Write size
	7th	sX7	sX6	sX5	sX4	sX3	sX2	sX1	sX0		
sY	8th	*	*	*	*	*	*	sY2	sY1	sY0	Height of Write size
B	9th	*	*	*	*	*	*	B1	B0	Block	
Fr	10th	Fr15	Fr14	Fr13	Fr12	Fr11	Fr10	Fr9	Fr8	Start address of FROM for read	
	11th	Fr7	Fr6	Fr5	Fr4	Fr3	Fr2	Fr1	Fr0		

3rd / 4th byte

pX8	pX7	pX6	pX5	pX4	pX3	pX2	pX1	pX0	Start write on left position
0	0	0	0	0	0	0	0	0	0
0	0	0	0	0	0	0	0	1	1
0	0	0	0	0	0	0	1	0	2
:									:
1	1	1	1	1	1	1	1	0	510
1	1	1	1	1	1	1	1	1	511

5th byte

pY2	pY1	pY0	Start write on top position
0	0	0	0
0	0	1	1
0	1	0	2
:			:
1	1	0	6
1	1	1	7

6th / 7th byte

sX8	sX7	sX6	sX5	sX4	sX3	sX2	sX1	sX0	Width of Write size
0	0	0	0	0	0	0	0	0	1 dot
0	0	0	0	0	0	0	0	1	2 dot
0	0	0	0	0	0	0	1	0	3 dot
:									:
1	1	1	1	1	1	1	1	0	511 dot
1	1	1	1	1	1	1	1	1	512 dot

8th byte

sY2	sY1	sY0	Height of Write size
0	0	0	8 dot
0	0	1	16 dot
0	1	0	24 dot
:			:
1	1	0	56 dot
1	1	1	64 dot

9th ~ 11th byte

B1	B0	Fr15	Fr14	Fr13	- - -	Fr2	Fr1	Fr0	FROM collect address
0	0	0	0	0		0	0	0	00000h
0	0	0	0	0		0	0	1	000001h
0	0	0	0	0		0	1	0	000002h
:									:
1	1	1	1	1		1	1	0	03FFFh
1	1	1	1	1		1	1	1	03FFFh

03FFFh – FROM storage address(B[1..0],Fe[15..0]) ≥ Write size width (sX) × Write size height (sY)

Function : The data is transferred to memory area from storage address of FROM(B[1..0],Fe[15..0]).

- BMP data registered in assigned position of FROM is written vertically from write start position (pX[8..0]\_pY[2..0]). After writing height size (sY[2..0]), the write position shifts to a line on the right.
- The command is completed after writing data horizontally amount of write width size (sX[8..0]).
- If FROM address is BMP area (03FFFh), writing data is ended at the time.

Command name : Cursor position Set

Code : 1Bh,30h,cX,cY

MSB					LSB					
Code	Byte	Bit7	Bit6	Bit5	Bit4	Bit3	Bit2	Bit1	Bit0	Note
1Bh	1st	0	0	0	1	1	0	1	1	
30h	2nd	0	0	1	1	0	0	0	0	Cursor position setting command
cX	3rd	*	*	*	*	*	*	*	cX8	x position
	4th	cX7	cX6	cX5	cX4	cX3	cX2	cX1	cX0	
cY	5th	*	*	*	*	*	cY2	cY1	cY0	y position

Function : Set write text position of cursor.

- In the display area, the cursor position is set in x, y position (cX[8..0],cY[2..0]).

Command name : Language Set

Code : 1Bh,32h,La

MSB					LSB					
Code	Byte	Bit7	Bit6	Bit5	Bit4	Bit3	Bit2	Bit1	Bit0	Note
1Bh	1st	0	0	0	1	1	0	1	1	
32h	2nd	0	0	1	1	0	0	1	0	Language setting command
La	3rd	*	*	*	*	*	*	*	La	

3rd byte

La	Language set
0	Simplified Chinese
1	Traditional Chinese
2	Japanese
3	Korea

Function : Language of text data is set to Simplified Chinese, Traditional Chinese, Japanese or Korea.

- This command is effective for Text Write Mode and Text Scroll Mode.
- This command does not influence already displayed data.

Command name : Text size Set

Code : 1Bh,33h,Fo

MSB					LSB					
Code	Byte	Bit7	Bit6	Bit5	Bit4	Bit3	Bit2	Bit1	Bit0	Note
1Bh	1st	0	0	0	1	1	0	1	1	
33h	2nd	0	0	1	1	0	0	1	1	
Fo	3rd	*	*	*	*	*	*	*	Fo	

3rd byte

Fo	Font setting
0	16×16 size font
1	6×8 size font

Function : Font size of Text data is set.

- This command is effective for Text Write Mode and Text Scroll Mode.
- This command does not influence already displayed data.



Command name : User definable font ON/OFF Set

Code : 1Bh,34h,Ga

Code	Byte	MSB					LSB			Note
		Bit7	Bit6	Bit5	Bit4	Bit3	Bit2	Bit1	Bit0	
1Bh	1st	0	0	0	1	1	0	1	1	
34h	2nd	0	0	1	1	0	1	0	0	User definable font ON/OFF
Ga	3rd	*	*	*	*	*	*	*	Ga	

3rd byte		Ga	User definable font set
		0	User definable font disable
		1	User definable font enable

Function: User definable font ON/OFF command. (Only for 6x8 and 8x16 character.)

- This command is effective for Text Write Mode and Text Scroll Mode.
- This command does not influence already displayed data.

#### Write One-byte font (or one-byte user definable font) : 20h~7Fh

- If first byte is 20h~7Fh, the cursor is set to the upper left of font, and an one-byte font is written in the memory area.
- This mode is reflected to Language, Text Size and User definable font ON/OFF.
- If the code which carried out User definable font registration is specified, User definable fonts are displayed. If the codes other than User definable font registration are specified, build-in fonts are displayed.
- Text size is the value set up in text size mode.
- A cursor moves by one character after writing text data.

#### Write Two-byte font : 80\*\*h~FD\*\*h

- If first Byte is 80\*\*h~FD\*\*h, after obtaining the 2nd byte, Two-byte font is written in memory area.
- This mode is reflected to Language and Text Size.
- If text size is set font 6x8, this command is taken as the illegal command.
- A cursor moves by one character after writing text data.
- Don't specify the area where the build-in fonts are not registered.

#### Write Two-byte User definable font : FEA1h~FEB0h

- If first byte is FEh, after obtaining the second byte, Two-byte user definable font is written in memory area.
- This mode is reflected to Language, Text Size and User definable font ON/OFF.
- If the User definable font set is OFF, text data is written as blank character.
- If text size is set font 6x8, this command is taken as the illegal command.
- A cursor moves by one character after writing text data.
- Don't specify the outside of the User definable font registration area range.

Command name: Scroll box Set

Code : 1Bh,40h,pX,pY,sX,sY

Code	Byte	MSB					LSB			Note
		Bit7	Bit6	Bit5	Bit4	Bit3	Bit2	Bit1	Bit0	
1Bh	1st	0	0	0	1	1	0	1	1	
40h	2nd	0	1	0	0	0	0	0	0	Scroll box size setting command
pX	3rd	*	*	*	*	*	*	*	pX8	Left position of box
	4th	pX7	pX6	pX5	pX4	pX3	pX2	pX1	pX0	
pY	5th	*	*	*	*	*	pY2	pY1	pY0	Upper position of box
sX	6th	*	*	*	*	*	*	*	sX8	Width of box size
	7th	sX7	sX6	sX5	sX4	sX3	sX2	sX1	sX0	
sY	8th	*	*	*	*	*	sY2	sY1	sY0	Height of box size

3rd / 4th byte	pX8	pX7	pX6	pX5	pX4	pX3	pX2	pX1	pX0	Left position of box
	0	0	0	0	0	0	0	0	0	0
	0	0	0	0	0	0	0	0	1	1
	0	0	0	0	0	0	0	1	0	2
	:									:
	1	1	1	1	1	1	1	0	1	509
	1	1	1	1	1	1	1	1	0	510
	1	1	1	1	1	1	1	1	1	511

5th byte	pY2	pY1	pY0	Upper position of box
	0	0	0	0
	0	0	1	1
	0	1	0	2
	:			:
	1	1	0	6
	1	1	1	7 (※Only 6*8 font size)

6th / 7th byte	sX8	sX7	sX6	sX5	sX4	sX3	sX2	sX1	sX0	Width of box size
	0	0	0	0	0	0	0	0	0	1 dot
	0	0	0	0	0	0	0	0	1	2 dot
	0	0	0	0	0	0	0	1	0	3 dot
	:									:
	0	1	0	0	1	1	1	1	1	158 dot
	0	1	0	1	0	0	0	0	0	159 dot
	0	1	0	1	0	0	0	0	1	160 dot

8th byte	Height of box size
	Font size 8*16 16 dot
	Font size 6*8 8 dot

Function: Scroll box is set

Text is scrolled by BOX size set by this command.

Setting with scroll box position (pX[8..0],pY[2..0]) and box size (sX[8..0],sY[2..0]) in this command.

If other command is inputted during scroll mode, the scroll is stopped.

If the scroll box is changed during scroll mode, it is necessary to write a text or BMP data into memory area again even if its data is same.

The BOX position can be assigned only the inside of display area (MAX 160 dot).

Command name: Setting of scroll speed

Code : 1Bh,41h,S

Code	Byte	MSB					LSB			Note
		Bit7	Bit6	Bit5	Bit4	Bit3	Bit2	Bit1	Bit0	
1Bh	1st	0	0	0	1	1	0	1	1	
41h	2nd	0	1	0	0	0	0	0	1	Scroll speed setting command
S	3rd	*	*	*	*	S3	S2	S1	S0	Speed Set

3rd byte	S3	S2	S1	S0	Speed
	0	0	0	0	1 dot / approx 10ms(2x speed)
	*1h ~ 1Fh				1 dot / (S[3..0])×approx. 20ms)

Function: Scroll speed is set

The scroll speed is rough standard.

Command name: Text scroll character Set

Code : 1Bh,50h,tL

Code	Byte	MSB							LSB		Note
		Bit7	Bit6	Bit5	Bit4	Bit3	Bit2	Bit1	Bit0		
1Bh	1st	0	0	0	1	1	0	1	1		
50h	2nd	0	1	0	1	0	0	0	0	Write scroll text	
tL	3rd	tL7	tL6	tL5	tL4	tL3	tL2	tL1	tL0	Text data length (byte)	
Data	4th ~									Scroll text data	

Function: Text scroll character is set.

Command name: Text scroll start.

Code : 1Bh,51h

Code	Byte	MSB							LSB		Note
		Bit7	Bit6	Bit5	Bit4	Bit3	Bit2	Bit1	Bit0		
1Bh	1st	0	0	0	1	1	0	1	1		
51h	2nd	0	1	0	1	0	0	0	1	Text scroll start command	

Function: Text scroll start command.

- If other command is inputted during scroll mode, the scroll is stopped immediately.

Command name: Enable FROM register mode.

Code : 1Ah,A0h

Code	Byte	MSB						LSB		Note
		Bit7	Bit6	Bit5	Bit4	Bit3	Bit2	Bit1	Bit0	
1Ah	1st	0	0	0	1	1	0	1	0	
A0h	2nd	1	0	1	0	0	0	0	0	Enable FROM register mode

Function: Switch to FROM register mode.

- The display and VFD power is OFF during FROM register mode.
- Only first command after module power on can be effective.

Command name: Disable FROM register mode.

Code : 1Ah,A1h

Code	Byte	MSB						LSB		Note
		Bit7	Bit6	Bit5	Bit4	Bit3	Bit2	Bit1	Bit0	
1Ah	1st	0	0	0	1	1	0	1	0	
A1h	2nd	1	0	1	0	0	0	0	1	Disable FROM register mode

Function: Disable FROM register mode and switch to normal mode, after software reset.

- The command is effective only when FROM register mode.

Command name : Define the BMP data to FROM

Code : 1Ah,A2h,B,Fw,Data

Code	Byte	MSB						LSB		Note
		Bit7	Bit6	Bit5	Bit4	Bit3	Bit2	Bit1	Bit0	
1Ah	1st	0	0	0	1	1	0	1	0	
A2h	2nd	1	0	1	0	0	0	1	0	Define the BMP data command
B	3rd	*	*	*	*	*	*	B1	B0	Block
FW	4th	Fw15	Fw14	Fw13	Fw12	Fw11	Fw10	Fw9	Fw8	Length of Write data (byte)
	5th	Fw7	Fw6	Fw5	Fw4	Fw3	Fw2	Fw1	Fw0	
Data	6th ~									Write data (1~65536 byte)

3rd byte	B1	B0	Write block
	0	0	Block 0
	0	1	Block 1
	1	0	Block 2
	1	1	Block 3

4th / 5th byte	Fw15	Fw14	Fw13	Fw12	...	Fw3	Fw2	Fw1	Fw0	Write data length (byte)
	0	0	0	0		0	0	0	0	1byte
	0	0	0	0		0	0	0	1	2 byte
	0	0	0	0		0	0	1	0	3 byte
	:									:
	1	1	1	1		1	1	1	0	65535 byte
	1	1	1	1		1	1	1	1	65536 byte

Function: Define the BMP data to FROM.

- The BMP data (Fw[15..0]) is written from address 0000h of each block (B[1..0]) of FROM.
- Define the BMP data to FROM, after delete the BMP data to FROM.
- The registered in BMP data can be displayed when data transfer.
- This command is effective only when FROM register mode.

Command name : Define the user definable font(16×16 font)

Code : 1Ah,A3h,Fb,Data

MSB					LSB					Note
Code	Byte	Bit7	Bit6	Bit5	Bit4	Bit3	Bit2	Bit1	Bit0	
1Ah	1st	0	0	0	1	1	0	1	0	
A3h	2nd	1	0	1	0	0	0	1	1	Logged mode of user definable font (16×16 font)
Fb	3rd	*	*	*	*	Fb3	Fb2	Fb1	Fb0	Logged of text number
Data	4th ~									Write in data 1 text=32byte×(Fb+1)

Function : Define the user definable font of 16×16 dot.

- The address of FROM is written in order from FEA1h to FEB0h.
- The data of font is written in order from the start address(d1).  
(Refer to user definable font register table.)
- Define the BMP data to FROM, after delete the BMP data to FROM.
- This command is effective only when FROM register mode.
- The User definable font can be displayed on condition that User definable font ON/OFF command is “ON”.

Command name : Define the user definable font(8×16 font)

Code : 1Ah,A4h,Fb,Ra,Data

MSB					LSB					Note
Code	Byte	Bit7	Bit6	Bit5	Bit4	Bit3	Bit2	Bit1	Bit0	
1Ah	1st	0	0	0	1	1	0	1	0	
A4h	2nd	1	0	1	0	0	1	0	0	Define the user definable font (8×16 font)
Fb	3rd	*	*	*	*	Fb3	Fb2	Fb1	Fb0	The number of register font
Ra	4rd	*	Ra6	Ra5	Ra4	Ra3	Ra2	Ra1	Ra0	Register address
Data	5th ~									Write data 1 text=16byte

Function : Define the user definable font of 8×16 dot.

- The address of 00h~1Fh is not available.
- The data of font is written in order from the start address(d1).  
(Refer to user definable font register table.)
- Define the BMP data to FROM, after delete the BMP data to FROM.
- This command is effective only when FROM register mode.
- The User definable font can be displayed on condition that User definable font ON/OFF command is “ON”.

Command name : Define the user definable font(6×8 font)

Code : 1Ah,A5h,Fb,Ra,Data

MSB					LSB					Note
Code	Byte	Bit7	Bit6	Bit5	Bit4	Bit3	Bit2	Bit1	Bit0	
1Ah	1st	0	0	0	1	1	0	1	0	
A5h	2nd	1	0	1	0	0	1	0	1	Define the user definable font (6×8 font)
Fb	3rd	*	*	*	*	Fb3	Fb2	Fb1	Fb0	The number of register font
Ra	4rd	*	Ra6	Ra5	Ra4	Ra3	Ra2	Ra1	Ra0	Register address
Data	5th ~									Write data 1 text=6byte

Function : Define the user definable font of 6×8 dot.

- The address of 00h~1Fh is not available.
- The data of font is written in order from the start address(d1).  
(Refer to user definable font register table.)
- Define the BMP data to FROM, after delete the BMP data to FROM.
- This command is effective only when FROM register mode.
- The User definable font can be displayed on condition that User definable font ON/OFF command is “ON”.

< User definable font register table >

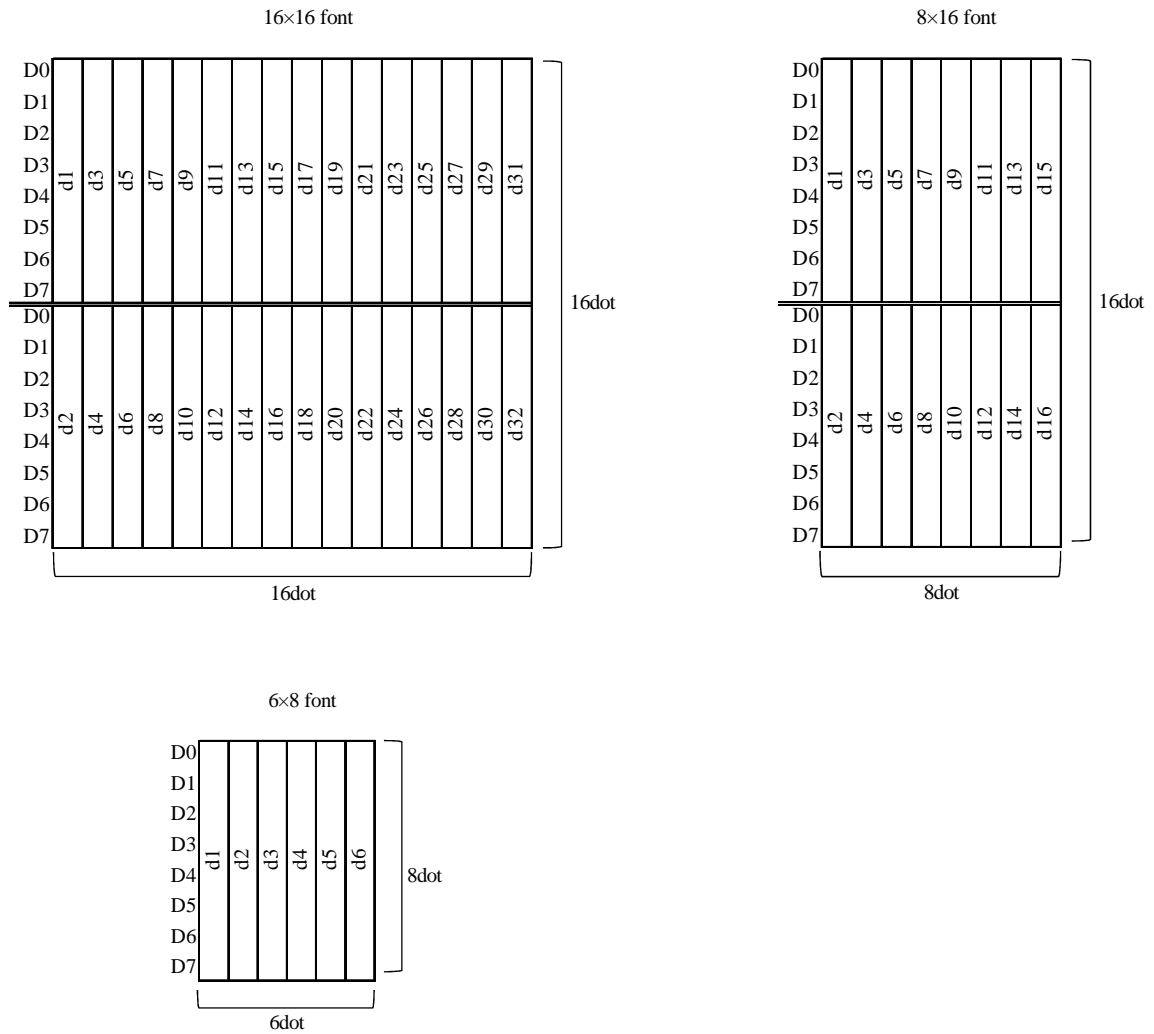

Command name : FROM data clear

Code : 1Ah,A7h,DF

Code	Byte	MSB					LSB			Note
		Bit7	Bit6	Bit5	Bit4	Bit3	Bit2	Bit1	Bit0	
1Ah	1st	0	0	0	1	1	0	1	0	
A7h	2nd	1	0	1	0	0	1	1	1	FROM data clear command
DF	3rd	*	*	*	*	*	*	0	DF	Clear content

3rd byte

DF	Clear content
0	BMP data field
1	User definable font field

Function : Clear the registered BMP or User definable font data in FORM.

- It is necessary to execute this command before defining the User definable font.
- This command is effective only when FROM register mode.

## Example of command sequence

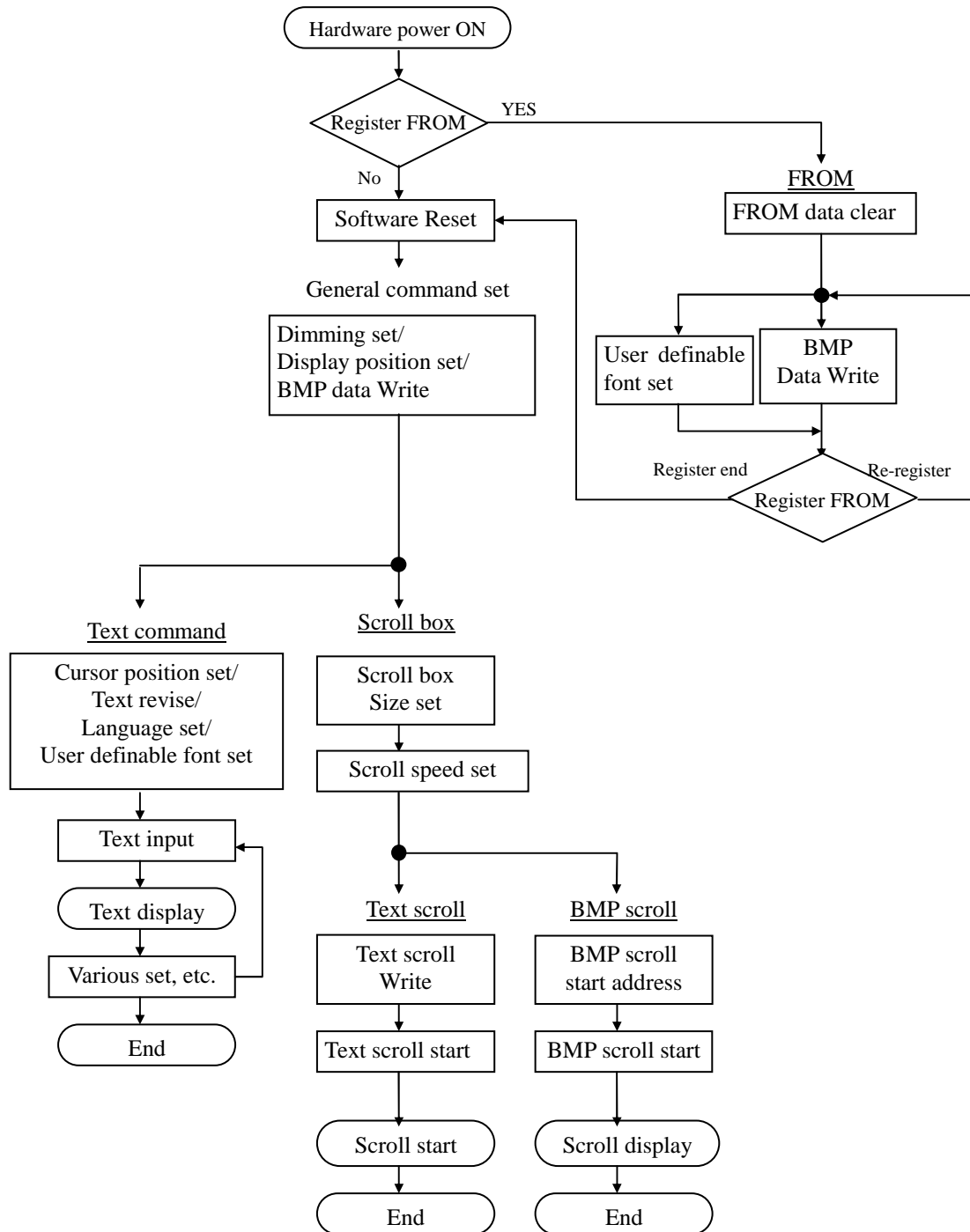

(※) FROM register mode : Only first command after hardware power ON can be effective.

(※) In order to malfunction wrong action, please keep signal steady after hardware power ON.

(※) It takes approx 10sec to clear FROM data. If receive buffer default is full during FROM clear, "BUSY" is outputted until processing of data is finished.

## 5. Interface

## 5-1. Connector

CN1 (USB HID)  $\phi$  1.1mm hole 6Pin(2.54mm pitch)

Table-15

Pin No.	Signal	Note
1	+5V	+5V
2	D+	Data
3	D-	Data
4	VBUS	-
5	LGND	Logic GND
6	GND	GND



## 6. The environmental specifications for this product

The product applies to RoHS.

### 6-1. With respect to EU RoHS Directive

The contained amount of six prohibited substances in this product, which are cadmium, hexavalent chromium, lead, mercury, polybrominated biphenyl:PBB and polybrominated diphenyl ether :PBDE, is less than the permitted level stipulated in the EU RoHS Directive, or these substances are not included in the Directive.

The substances excluded are based on Article 4 of the EU RoHS Directive.

### 6-2. With respect to Chinese RoHS

This product contains only “lead and its compound” from among six controlled substances, which are cadmium, hexavalent chromium, lead, mercury, polybrominated biphenyl:PBB and polybrominated diphenyl ether :PBDE.

The contained amount of the controlled substances except lead and its compound in this product is less than the level stipulated in the Chinese RoHS.

As for the display of information on containing EHS, please refer to the following.

< Display of information on containing EHS >

\*Product and part the substances are contained: Vacuum Fluorescent Display (VFD)

\*Chemical materials contained: Lead and its compound

\*Time limit of use for environmental protection: 10 years

\*Reason for containing the substances: No materials are available except them under the current technology.

## 7. CAUTIONS FOR OPERATION

7-1. Since VFD is made of glass material, avoid applying excessive shock or vibration beyond the specification for the module. Careful handling is essential.

7-2. Applying lower voltage than the specified may cause non activation for selected pixels.

Conversely, higher voltage may cause non-selected pixel to be activated.

If such a phenomenon is observed, check the voltage level of the power supply.

7-3. If the startup time of the supply voltage is slow, the controller may not be reset.

The supply voltage must be risen up to specified voltage level within 30msec.

7-4. DC/DC converter is equipped on the module, the surge current may be approximately 5 times the specified supply current at the power on.

7-5. Avoid using the module where excessive noise interface is expected. Noise affects the interface signal and cause improper operation. Keep the length of the interface cable less than 30cm.(When the longer cable is required, please confirm there is no noise affection.)

7-6. When fixed pattern is displayed for long time, you may see uneven luminance. It is recommended to change the display patterns sometimes in order to keep best display quality.

Mechanical Drawing

FIGURE-1

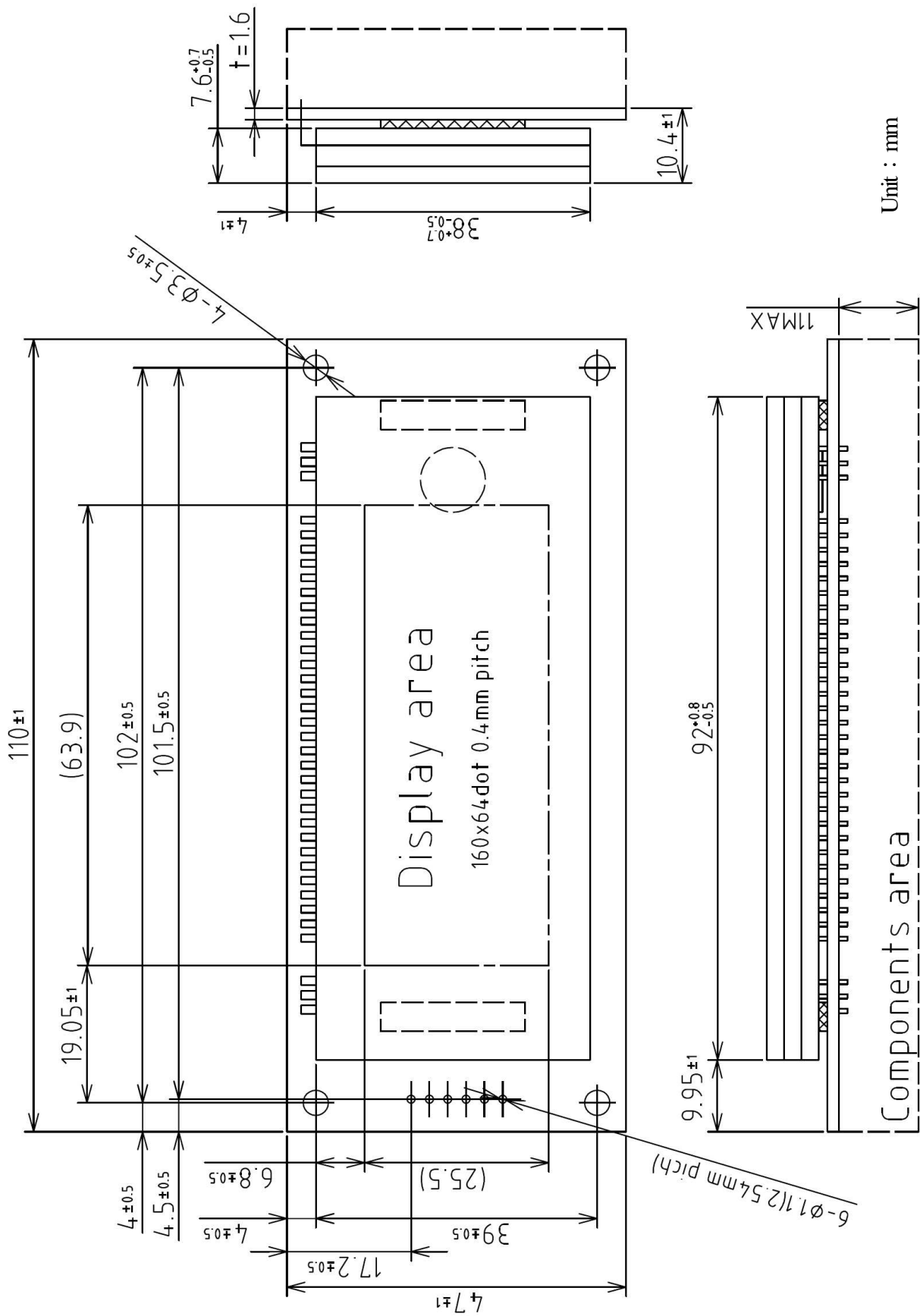

Unit : mm

Block Diagram

FIGURE-2

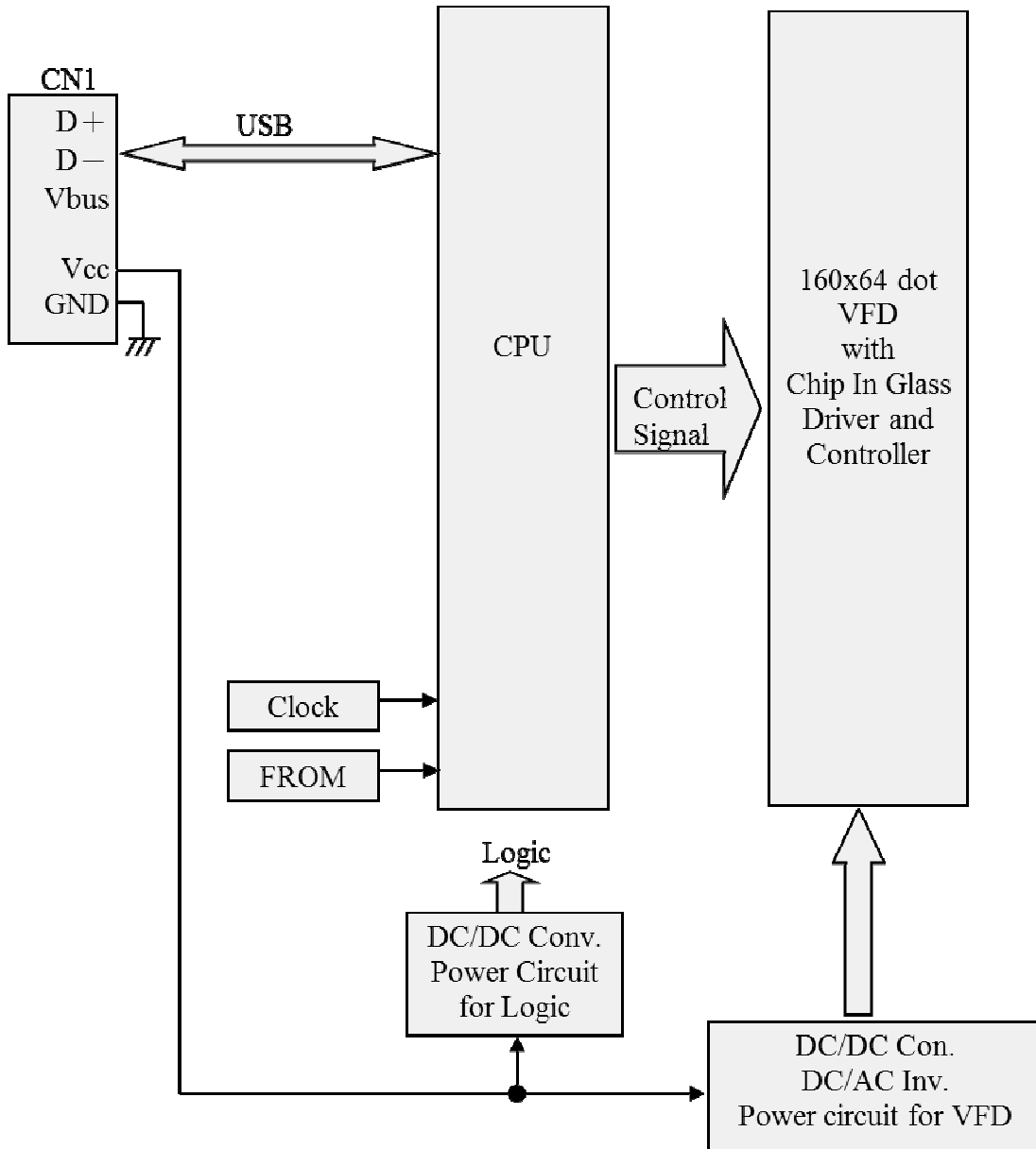

DISPLAY CHARACTER CODE

(a) Simplified Chinese (GB2312)

	+0	+1	+2	+3	+4	+5	+6	+7	+8	+9	+A	+B	+C	+D	+E	+F	+10	+11	+12	+13	+14	+15	+16	+17	+18	+19	+1A	+1B	+1C	+1D	+1E	+1F		
A1A0	□	□	。	•	□	□	••	々	一	~		...	□	□	□	□	□	□	□	□	□	□	□	□	□	□	□	□	□	□	□	□		
A1C0	±	×	÷	∴	∧	∨	∑	∏	∪	∩	€	∴	✓	⊥	∥	∠	∩	◎	∫	∫	≡	≡	≈	∞	∞	≠	≠	≠	≠	∞	∴			
A1E0	•	♂	♀	°	□	□	°	°	°	°	°	°	°	°	°	°	°	°	°	°	°	°	°	°	°	°	°	°	°	°	°	°		
A2A0																																		
A2C0	16.	17.	18.	19.	20.	(1)	(2)	(3)	(4)	(5)	(6)	(7)	(8)	(9)	(10)	(11)	(12)	(13)	(14)	(15)	(16)	(17)	(18)	(19)	(20)	①	②	③	④	⑤	⑥	⑦		
A2E0	⑧	⑨	⑩																															
A3A0	!	"	#	¥	%	&	'	(	)	*	+	,	-	.	/	0	1	2	3	4	5	6	7	8	9	:	;	<	=	>	?			
A3C0	@	A	B	C	D	E	F	G	H	I	J	K	L	M	N	O	P	Q	R	S	T	U	V	W	X	Y	Z	[	\	]	^	□		
A3E0	□	a	b	c	d	e	f	g	h	i	j	k	l	m	n	o	p	q	r	s	t	u	v	w	x	y	z	{		}	□			
A4A0	あ	あ	い	い	う	う	え	え	お	お	か	か	き	き	く	く	け	け	こ	こ	さ	さ	し	し	ず	ず	せ	せ	そ	そ	た			
A4C0	だ	ち	ち	つ	つ	づ	て	て	と	と	な	に	ぬ	ぬ	の	の	は	は	ば	ば	ひ	ひ	び	び	ふ	ふ	ぶ	へ	へ	べ	べ	ま		
A4E0	む	め	も	や	や	ゆ	ゆ	よ	よ	ら	ら	り	る	る	わ	わ	ゑ	ゑ	を	を	ん													
A5A0	ア	ア	イ	イ	ウ	ウ	エ	エ	オ	オ	カ	カ	キ	キ	ク	ク	ケ	ケ	コ	コ	サ	サ	シ	シ	ス	ス	セ	セ	ソ	ソ	タ			
A5C0	夕	チ	チ	ツ	ツ	ツ	テ	テ	ト	ト	ナ	ナ	ニ	ニ	ネ	ネ	ノ	ノ	ハ	ハ	パ	パ	ヒ	ヒ	フ	フ	フ	ヘ	ヘ	ペ	ペ	マ		
A5E0	ム	メ	モ	ヤ	ヤ	ユ	ユ	ヨ	ヨ	ラ	ラ	リ	ル	ル	レ	レ	ワ	ワ	ヰ	ヰ	ヱ	ヱ	ヰ	ヰ	ヱ	ヱ	ヰ	ヰ	ヱ	ヱ	ヰ	ヰ		
A6A0	A	B	Γ	Δ	E	Z	H	Θ	I	K	Λ	M	N	Ξ	O	Π	P	Σ	T	T	Φ	X	Ψ	Ω										
A6C0	α	β	γ	δ	ε	ζ	η	θ	ι	κ	λ	μ	ν	ξ	ο	π	ρ	σ	τ	υ	φ	χ	ψ	ω										
A6E0																																		
A7A0	А	В	В	Г	Д	Е	Ё	Ж	З	И	Й	К	Л	М	Н	О	П	Р	С	Т	У	Ф	Х	Ц	Ч	Ш	Ш	Ъ	Ы	Ь	Э			
A7C0	Ю	Я																																
A7E0	о	п	р	с	т	у	ф	х	ц	ч	ш	ш	ъ	ы	ь	э	ю	я																
A8A0	ā	á	ǎ	à	ē	é	ě	è	í	í	ÿ	ì	ō	ó	õ	ò	ū	ú	ǔ	ù	ū	ú	ǔ	ù	ú	ê								
A8C0																																		
A8E0	么	又	孛	孛	尢	厶	儿	丨	又	厶																								
A9A0																																		
A9C0	卍	卍	卍	卍	卍	卍	卍	卍	卍	卍	卍	卍	卍	卍	卍	卍	卍	卍	卍	卍	卍	卍	卍	卍	卍	卍	卍	卍	卍	卍	卍	卍		
A9E0	卍	卍	卍	卍	卍	卍	卍	卍	卍	卍	卍	卍	卍	卍	卍	卍	卍	卍	卍	卍	卍	卍	卍	卍	卍	卍	卍	卍	卍	卍	卍	卍		
AAA0																																		
AAC0																																		
AAE0																																		
ABA0																																		
ABC0																																		
ABE0																																		
ACA0																																		
ACC0																																		
ACE0																																		
ADA0																																		
ADC0																																		
ADE0																																		
AEA0																																		
AEC0																																		
AEE0																																		
AFA0																																		
AFC0																																		
AFE0																																		
BOA0	啊	阿	埃	挨	哎	唉	哀	皑	癌	蔼	矮	艾	碍	爱	隘	鞅	氨	安	俺	按	暗	岸	腕	案	腕	昂	盎	凹	敖	熬	翱			
BOC0	袄	傲	奥	澳	芭	捌	扒	叭	吧	芭	疤	巴	拔	跋	靶	把	耙	坝	霸	罢	爸	柏	百	摆	佰	败	拜	裨	斑					
BOE0	班	搬	扳	般	颁	板	版	扮	拌	伴	瓣	半	办	绊	邦	帮	梆	榜	膀	绑	棒	磅	蚌	镑	镑	滂	苞	胞	包	褒	剥			



(c)日本語(Shift-JIS)

	+0	+1	+2	+3	+4	+5	+6	+7	+8	+9	+A	+B	+C	+D	+E	+F	+10	+11	+12	+13	+14	+15	+16	+17	+18	+19	+1A	+1B	+1C	+1D	+1E	+1F		
8140	□	□	□	□	□	□	□	□	□	□	□	□	□	□	□	□	□	□	□	□	□	□	□	□	□	□	□	□	□	□	□	□	□	
8160	~			...	..	'	'	“	”	(	)	(	)	[	]	{	}	<	>	《	》	「	」	『	』	【	】	+	-	±	×			
8180	÷	=	≠	<	>	≤	≥	∞	∴	♂	♀	°	′	″	℃	¥	\$	¢	£	%	#	&	*	@	§	☆	★	○	●	◎	◇	◆		
81A0	□	■	△	▲	▽	▼	※	〒	→	←	↑	↓	≡																					
81C0										∧	∨	↗	⇒	⇔	∇	∃																		
81E0	≡	≪	≫	√	∞	∞	∴	∫	∫																									
8240																																		
8260	A	B	C	D	E	F	G	H	I	J	K	L	M	N	O	P	Q	R	S	T	U	V	W	X	Y	Z								
8280	a	b	c	d	e	f	g	h	i	j	k	l	m	n	o	p	q	r	s	t	u	v	w	x	y	z								
82A0	あ	い	い	う	う	え	え	お	お	か	か	き	ぎ	く	く	け	げ	こ	こ	さ	ざ	し	じ	ず	ず	せ	ぜ	そ	そ	た	だ	ち		
82C0	ぢ	つ	つ	づ	て	で	と	ど	な	に	ぬ	ね	の	は	ば	び	び	び	ぶ	ぶ	ぶ	へ	へ	へ	ほ	ほ	ぼ	ま	み	む	め			
82E0	も	や	や	ゆ	ゆ	よ	よ	ら	り	る	れ	ろ	わ	わ	ゑ	を	ん																	
8340	ア	ア	イ	イ	ウ	ウ	エ	エ	オ	オ	カ	カ	キ	キ	ク	ク	ケ	ケ	コ	コ	サ	ザ	シ	ジ	ス	ズ	セ	ゼ	ソ	ゾ	タ	ダ		
8360	チ	チ	ツ	ツ	ヅ	テ	テ	ト	ド	ナ	ニ	ヌ	ノ	ハ	バ	パ	ヒ	ビ	ピ	フ	ブ	フ	ヘ	ベ	ホ	ボ	ポ	マ	ミ					
8380	△	×	モ	ヤ	ユ	ユ	ヨ	ヨ	ラ	リ	ル	レ	ロ	ワ	ヅ	ヅ	ヅ	ヅ	ヅ	ヅ	ヅ	ヅ	ヅ	ヅ	ヅ	ヅ	ヅ	ヅ	ヅ	ヅ	ヅ	ヅ		
83A0	Β	Γ	Δ	E	Z	H	Θ	I	K	Λ	M	N	Ξ	O	Π	P	Σ	T	Υ	Φ	X	Ψ	Ω											
83C0	β	γ	δ	ε	ζ	η	θ	ι	κ	λ	μ	ν	ξ	ο	π	ρ	σ	τ	υ	φ	χ	ψ	ω											
83E0																																		
8440	А	Б	В	Г	Д	Е	Ё	Ж	З	И	Й	К	Л	М	Н	О	П	Р	С	Т	У	Ф	Х	Ц	Ч	Ш	Щ	Ъ	Ы	Ь	Э	Ю		
8460	Я																																	
8480	о	п	р	с	т	у	ф	х	ц	ч	ш	щ	ъ	ы	ь	э	ю	я																
84A0	П	Р	С	Т	У	Ф	Х	Ц	Ч	Ш	Щ	Ъ	Ы	Ь	Э	Ю	Я																	
8740	①	②	③	④	⑤	⑥	⑦	⑧	⑨	⑩	⑪	⑫	⑬	⑭	⑮	⑯	⑰	⑱	⑳	Ⅰ	Ⅱ	Ⅲ	Ⅳ	Ⅴ	Ⅵ	Ⅶ	Ⅷ	Ⅷ	Ⅸ	Ⅹ				
8760	キ	キ	キ	キ	キ	キ	キ	キ	キ	キ	キ	キ	キ	キ	キ	キ	キ	キ	キ	mm	cm	km	mg	kg	cc	m <sup>2</sup>								
8780	□	□	No.	KK	TEL	☎	☎	☎	☎	☎	☎	☎	☎	☎	☎	☎	☎	☎	☎	☎	☎	☎	☎	☎	☎	☎	☎	☎	☎	☎	☎	☎		
87A0																																		
87C0																																		
87E0																																		
8840																																		
8860																																		
8880																																		
88A0	唾	娃	阿	哀	愛	挨	始	逢	葵	茜	穉	愚	握	渥	旭	葦	芦	鱒	粹	压	幹	扱	宛	姐	虻	飴	絢	綾	鮎	或	粟	裕		
88C0	安	庵	按	暗	案	闇	鞍	杏	以	伊	位	依	偉	因	夷	委	威	尉	惟	意	慰	易	椅	為	畏	異	移	維	緯	胃	萎	衣		
88E0	謂	違	遺	医	井	亥	域	育	郁	磯	一	壹	溢	逸	稻	茨	芋	鰯	允	印	咽	員	因	姻	引	飲	淫	胤	蔭					

(d) 韓國語(KSC5601)

	+0	+1	+2	+3	+4	+5	+6	+7	+8	+9	+A	+B	+C	+D	+E	+F	+10	+11	+12	+13	+14	+15	+16	+17	+18	+19	+1A	+1B	+1C	+1D	+1E	+1F								
A1A0	□	□	□	□	□	□	□	□	□	□	□	□	□	□	□	□	□	□	□	□	□	□	□	□	□	□	□	□	□	□	□	□	□	□						
A1C0	÷	×	≤	≥	∞	∴	°	′	″	°	′	″	°	′	″	°	′	″	°	′	″	°	′	″	°	′	″	°	′	″	°	′	″	°	′	″				
A1E0	□	■	▲	△	▽	▼	→	←	↑	↓	↔	≡	≪	≫	√	∞	∞	∴	∫	∫	∫	∫	∫	∫	∫	∫	∫	∫	∫	∫	∫	∫	∫	∫						
A2A0	⇒	⇐	▽	∩	∪	∩	∪	∩	∪	∩	∪	∩	∪	∩	∪	∩	∪	∩	∪	∩	∪	∩	∪	∩	∪	∩	∪	∩	∪	∩	∪	∩	∪	∩	∪					
A2C0	♣	♠	♦	♠	♣	♠	♣	♠	♣	♠	♣	♠	♣	♠	♣	♠	♣	♠	♣	♠	♣	♠	♣	♠	♣	♠	♣	♠	♣	♠	♣	♠	♣	♠	♣					
A2E0	No	Co	TM	am	pm	Tel																																		
A3A0	!	"	#	\$	%	&	'	(	)	*	+	,	-	.	/	0	1	2	3	4	5	6	7	8	9	:	;	<	=	>	?									
A3C0	@	A	B	C	D	E	F	G	H	I	J	K	L	M	N	O	P	Q	R	S	T	U	V	W	X	Y	Z	[	₩	]	^	□								
A3E0	`	a	b	c	d	e	f	g	h	i	j	k	l	m	n	o	p	q	r	s	t	u	v	w	x	y	z	{		}	□									
A4A0	ㄱ	ㅋ	ㆁ	ㄴ	ㄷ	ㄹ	ㅁ	ㅂ	ㅅ	ㅇ	ㅈ	ㅊ	ㅌ	ㅍ	ㅑ	ㅓ	ㅕ	ㅗ	ㅛ	ㅜ	ㅠ	ㅡ	ㅣ	ㅞ	ㅟ	ㅠ	ㅡ	ㅢ	ㅣ	ㅤ	ㅥ	ㅦ	ㅧ	ㅨ	ㅩ					
A4C0	ㅪ	ㅫ	ㅬ	ㅭ	ㅮ	ㅯ	ㅰ	ㅱ	ㅲ	ㅳ	ㅴ	ㅵ	ㅶ	ㅷ	ㅸ	ㅹ	ㅺ	ㅻ	ㅼ	ㅽ	ㅾ	ㅿ	ㆀ	ㆁ	ㆂ	ㆃ	ㆄ	ㆅ	ㆆ	ㆇ	ㆈ	ㆉ	ㆊ	ㆋ	ㆌ					
A4E0	ㅍ	ㅎ	ㅍ	ㅎ	ㅍ	ㅎ	ㅍ	ㅎ	ㅍ	ㅎ	ㅍ	ㅎ	ㅍ	ㅎ	ㅍ	ㅎ	ㅍ	ㅎ	ㅍ	ㅎ	ㅍ	ㅎ	ㅍ	ㅎ	ㅍ	ㅎ	ㅍ	ㅎ	ㅍ	ㅎ	ㅍ	ㅎ	ㅍ	ㅎ	ㅍ	ㅎ				
A5A0	i	ii	iii	iv	v	vi	vii	viii	ix	x																														
A5C0	A	B	Γ	Δ	E	Z	H	⊙	I	K	Λ	M	N	E	⊖	Π	P	Σ	T	T	Φ	X	Ψ	Ω																
A5E0	α	β	γ	δ	ε	ζ	η	θ	ι	κ	λ	μ	ν	ξ	ο	π	ρ	σ	τ	υ	φ	χ	ψ	ω																
A6A0	□	□	□	□	□	□	□	□	□	□	□	□	□	□	□	□	□	□	□	□	□	□	□	□	□	□	□	□	□	□	□	□	□	□	□	□				
A6C0	⊕	⊕	⊕	⊕	⊕	⊕	⊕	⊕	⊕	⊕	⊕	⊕	⊕	⊕	⊕	⊕	⊕	⊕	⊕	⊕	⊕	⊕	⊕	⊕	⊕	⊕	⊕	⊕	⊕	⊕	⊕	⊕	⊕	⊕	⊕					
A6E0	⊕	⊕	⊕	⊕	⊕	⊕	⊕	⊕	⊕	⊕	⊕	⊕	⊕	⊕	⊕	⊕	⊕	⊕	⊕	⊕	⊕	⊕	⊕	⊕	⊕	⊕	⊕	⊕	⊕	⊕	⊕	⊕	⊕	⊕	⊕					
A7A0	㎍	㎎	㎏	㎏	㎏	㎏	㎏	㎏	㎏	㎏	㎏	㎏	㎏	㎏	㎏	㎏	㎏	㎏	㎏	㎏	㎏	㎏	㎏	㎏	㎏	㎏	㎏	㎏	㎏	㎏	㎏	㎏	㎏	㎏	㎏	㎏				
A7C0	ns	us	ms	pV	nV	vV	mV	kV	MV	pA	nA	uA	mA	kA	pW	nW	vW	mW	kW	MW	Hz	kHz	MHz	GHz	THz	Ω	kΩ	MΩ	pF	nF	uF	mol								
A7E0	cd	rad	°	′	″	sr	Pa	kPa	MPa	GPa	Wb	lm	lx	Bq	Gy	Sv	%																							
A8A0	⊕	⊕	⊕	⊕	⊕	⊕	⊕	⊕	⊕	⊕	⊕	⊕	⊕	⊕	⊕	⊕	⊕	⊕	⊕	⊕	⊕	⊕	⊕	⊕	⊕	⊕	⊕	⊕	⊕	⊕	⊕	⊕	⊕	⊕	⊕					
A8C0	⊕	⊕	⊕	⊕	⊕	⊕	⊕	⊕	⊕	⊕	⊕	⊕	⊕	⊕	⊕	⊕	⊕	⊕	⊕	⊕	⊕	⊕	⊕	⊕	⊕	⊕	⊕	⊕	⊕	⊕	⊕	⊕	⊕	⊕	⊕	⊕				
A8E0	⊕	⊕	⊕	⊕	⊕	⊕	⊕	⊕	⊕	⊕	⊕	⊕	⊕	⊕	⊕	⊕	⊕	⊕	⊕	⊕	⊕	⊕	⊕	⊕	⊕	⊕	⊕	⊕	⊕	⊕	⊕	⊕	⊕	⊕	⊕	⊕				
A9A0	æ	đ	đ	h	i	ij	k	t	ı	ø	œ	ß	þ	t	n	n	(	)	(	)	(	)	(	)	(	)	(	)	(	)	(	)	(	)	(	)	(			
A9C0	⊕	⊕	⊕	⊕	⊕	⊕	⊕	⊕	⊕	⊕	⊕	⊕	⊕	⊕	⊕	⊕	⊕	⊕	⊕	⊕	⊕	⊕	⊕	⊕	⊕	⊕	⊕	⊕	⊕	⊕	⊕	⊕	⊕	⊕	⊕	⊕				
A9E0	(t)	(u)	(v)	(w)	(x)	(y)	(z)	(1)	(2)	(3)	(4)	(5)	(6)	(7)	(8)	(9)	(10)	(11)	(12)	(13)	(14)	(15)	¹	²	³	⁴	ⁿ	₁	₂	₃	₄									
AAA0	ㅏ	ㅑ	ㅓ	ㅕ	ㅗ	ㅛ	ㅜ	ㅠ	ㅡ	ㅣ	ㅞ	ㅟ	ㅠ	ㅡ	ㅢ	ㅣ	ㅤ	ㅥ	ㅦ	ㅧ	ㅨ	ㅩ	ㅪ	ㅫ	ㅬ	ㅭ	ㅮ	ㅯ	ㅰ	ㅱ	ㅲ	ㅳ	ㅴ	ㅵ	ㅶ	ㅷ				
AAC0	ㅸ	ㅹ	ㅺ	ㅻ	ㅼ	ㅽ	ㅾ	ㅿ	ㆀ	ㆁ	ㆂ	ㆃ	ㆄ	ㆅ	ㆆ	ㆇ	ㆈ	ㆉ	ㆊ	ㆋ	ㆌ	ㆍ	ㆎ	㆏	㆐	㆑	㆒	㆓	㆔	㆕	㆖	㆗	㆘	㆙	㆚	㆛	㆜			
AAE0	ㅞ	ㅟ	ㅠ	ㅡ	ㅢ	ㅣ	ㅤ	ㅥ	ㅦ	ㅧ	ㅨ	ㅩ	ㅪ	ㅫ	ㅬ	ㅭ	ㅮ	ㅯ	ㅰ	ㅱ	ㅲ	ㅳ	ㅴ	ㅵ	ㅶ	ㅷ	ㅸ	ㅹ	ㅺ	ㅻ	ㅼ	ㅽ	ㅾ	ㅿ	ㆀ	ㆁ				
ABA0	ㅠ	ㅡ	ㅢ	ㅣ	ㅤ	ㅥ	ㅦ	ㅧ	ㅨ	ㅩ	ㅪ	ㅫ	ㅬ	ㅭ	ㅮ	ㅯ	ㅰ	ㅱ	ㅲ	ㅳ	ㅴ	ㅵ	ㅶ	ㅷ	ㅸ	ㅹ	ㅺ	ㅻ	ㅼ	ㅽ	ㅾ	ㅿ	ㆀ	ㆁ	ㆂ	ㆃ	ㆄ			
ABC0	ㅵ	ㅶ	ㅷ	ㅸ	ㅹ	ㅺ	ㅻ	ㅼ	ㅽ	ㅾ	ㅿ	ㆀ	ㆁ	ㆂ	ㆃ	ㆄ	ㆅ	ㆆ	ㆇ	ㆈ	ㆉ	ㆊ	ㆋ	ㆌ	ㆍ	ㆎ	㆏	㆐	㆑	㆒	㆓	㆔	㆕	㆖	㆗	㆘	㆙	㆚		
ABE0	ㅞ	ㅟ	ㅠ	ㅡ	ㅢ	ㅣ	ㅤ	ㅥ	ㅦ	ㅧ	ㅨ	ㅩ	ㅪ	ㅫ	ㅬ	ㅭ	ㅮ	ㅯ	ㅰ	ㅱ	ㅲ	ㅳ	ㅴ	ㅵ	ㅶ	ㅷ	ㅸ	ㅹ	ㅺ	ㅻ	ㅼ	ㅽ	ㅾ	ㅿ	ㆀ	ㆁ	ㆂ			
ACA0	A	B	Γ	Δ	E	Ё	Ж	З	И	Й	K	Л	M	Н	О	П	Р	С	Т	У	Ф	Х	Ц	Ч	Ш	Щ	Ъ	Ы	Ь	Э										
ACC0	Ю	Я																																						
ACE0	О	П	Р	С	Т	У	Ф	Х	Ц	Ч	Ш	Щ	Ъ	Ы	Ь	Э	Ю	Я																						
ADA0																																								
ADC0																																								
ADE0																																								
AEA0																																								
AEC0																																								
AEE0																																								
AFA0																																								
AFC0																																								
AFE0																																								
BOA0	가	각	간	감	갈	값	값	값	값	값	값	값	값	값	값	값	값	값	값	값	값	값	값	값	값	값	값	값	값	값	값	값	값	값	값	값	값	값		
BOC0	값	값	값	값	값	값	값	값	값	값	값	값	값	값	값	값	값	값	값	값	값	값	값	값	값	값	값	값	값	값	값	값	값	값	값	값	값	값	값	
BOE0	값	값	값	값	값	값	값	값	값	값	값	값	값	값	값	값	값	값	값	값	값	값	값	값	값	값	값	값	값	값	값	값	값	값	값	값	값	값	값	