

# GP34119

## LOW POWER AUDIO AMPLIFIER

### Description

The GP34119 is a low power audio amplifier integrated circuit intended (primarily) for telephone applications, such as in speakerphones. It provides differential speaker outputs to maximize output swing at low supply voltages (2.0V minimum). Coupling capacitors to the speaker are not required. Open loop gain is 80 dB, and the closed loop gain is set with two external resistors. A Chip Disable pin permits powering down and/or muting the input signal.

### Features

- Wide Operating Supply Voltage Range (2.0V to 16V), Allows Telephone Line Powered Applications
- Low Quiescent Supply Current (2.7mA Typ) for Battery Powered Applications
- Chip Disable Input to Power Down the IC
- Low Power-Down Quiescent Current (65uA Typ)
- Drives a Wide Range of Speaker Loads (8.0Ω and Up)
- Output Power Exceeds 250 mW with 32Ω Speaker
- Low Total Harmonic Distortion (0.5% Typ)
- Gain Adjustable from <0 dB to >46 dB for Voice Band
- Requires Few External Components

### Package Dimensions

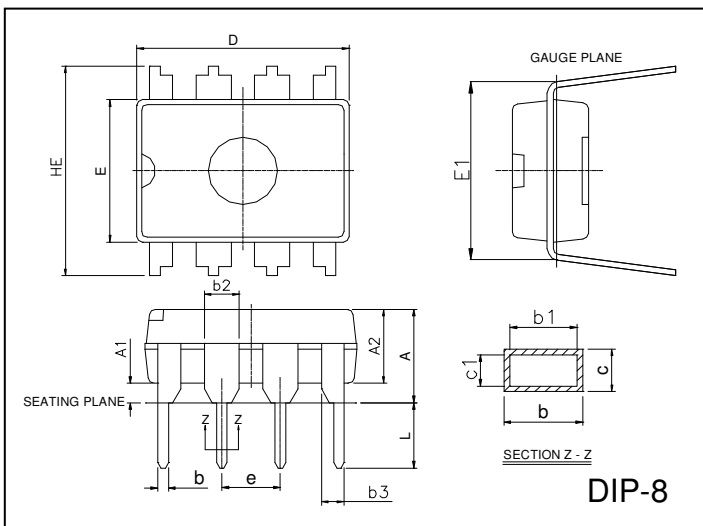

#### Marking:

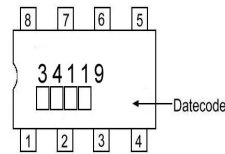

REF.	Millimeter		REF.	Millimeter	
	Min.	Max.		Min.	Max.
A	-	0.5334	c1	0.203	0.279
A1	0.381	-	D	9.017	10.16
A2	2.921	4.953	E	6.096	7.112
b	0.356	0.559	E1	7.620	8.255
b1	0.356	0.508	e	2.540 BSC	
b2	1.143	1.778	HE	-	10.92
b3	0.762	1.143	L	2.921	3.810
c	0.203	0.356			

### Block Diagram and Simplified Application & Pin Configuration

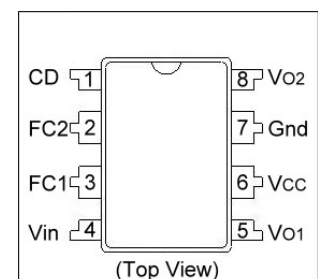
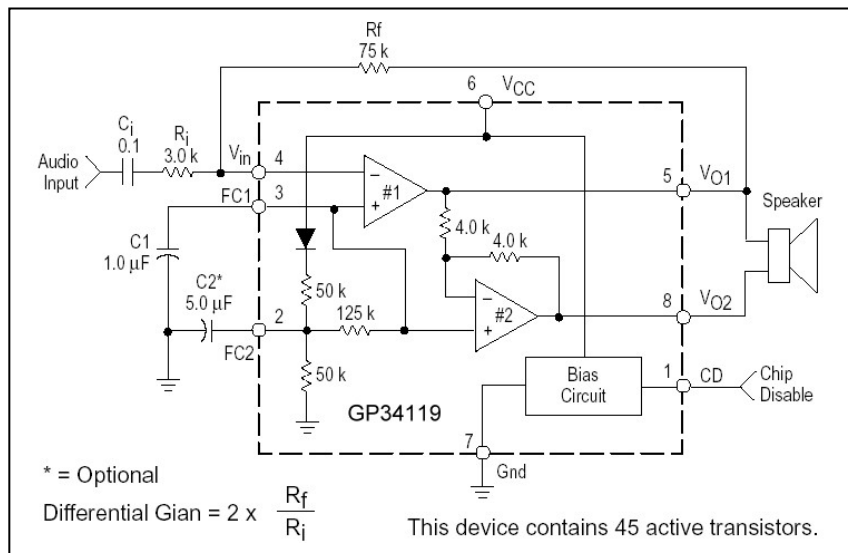

## Maximum Ratings

Rating	Value	Unit
Supply Voltage	-1.0 to +18	Vdc
Maximum Output Current at VO1, VO2	±250	mA
Maximum Voltage @ Vin, FC1, FC2, CD Applied Output Voltage to VO1, VO2 when disabled	-1.0, V <sub>CC</sub> +1.0 -1.0, V <sub>CC</sub> +1.0	Vdc
Junction Temperature	-55, +140	°C

Note: ESD data available upon request.

## Recommended Operating Conditions

Characteristics	Symbol	Min	Max	Unit
Supply Voltage	V <sub>CC</sub>	+2.0	+16	Vdc
Voltage @ CD (Pin 1)	V <sub>CD</sub>	0	V <sub>CC</sub>	Vdc
Load Impedance	R <sub>L</sub>	8.0	-	Ω
Peak Load Current	I <sub>L</sub>	-	±200	mA
Differential Gain (5.0kHz Bandwidth)	AVD	0	46	dB
Ambient Temperature	T <sub>A</sub>	-20	+70	°C

## Electrical Characteristics (T<sub>A</sub>=25°C unless otherwise noted.)

Characteristics	Symbol	Test Conditions	Min	Typ.	Max.	Unit
<b>Amplifiers (AC Characteristics)</b>						
AC Input Resistance	r <sub>i</sub>	@ Vin	-	>30	-	MΩ
Open Loop Gain	AVOL1	Amplifier #1, f<100Hz	80	-	-	dB
Close Loop Gain	Av2	Amplifier #2, V <sub>CC</sub> =6V, f=1kHz, R <sub>L</sub> =32Ω	-0.35	0	+0.35	dB
Gain Bandwidth Product	GBW	-	-	1.5	-	MHz
Output Power	P <sub>Out3</sub>	V <sub>CC</sub> = 3V, R <sub>L</sub> = 16Ω, THD ≤ 10%	55	-	-	mW
	P <sub>Out6</sub>	V <sub>CC</sub> = 6V, R <sub>L</sub> = 32Ω, THD ≤ 10%	250	-	-	
	P <sub>Out12</sub>	V <sub>CC</sub> =12V, R <sub>L</sub> =100Ω, THD ≤ 10%	400	-	-	
Total Harmonic Distortion (f=1kHz)	THD	V <sub>CC</sub> = 6V, R <sub>L</sub> =32Ω, P <sub>out</sub> =125mW	-	0.5	1.0	%
		V <sub>CC</sub> ≥ 3V, R <sub>L</sub> = 8Ω, P <sub>out</sub> = 20mW	-	0.5	-	
		V <sub>CC</sub> ≥ 12V, R <sub>L</sub> =32Ω, P <sub>out</sub> =200mW	-	0.6	-	
Power Supply Rejection (V <sub>CC</sub> =6V, ΔV <sub>CC</sub> =3V)	PSRR	C1=∞, C2=0.01uF	50	-	-	dB
		C1=0.1uF, C2=0, f=1kHz	-	12	-	
		C1=1.0uF, C2=5.0uF, f=1kHz	-	52	-	
Differential Muting	GMT	V <sub>CC</sub> =6V, 1kHz ≤ f ≤ 20kHz, CD=2V	-	>70	-	dB
<b>Amplifiers (DC Characteristics)</b>						
Output DC Level	VO(3)	VO1, VO2, V <sub>CC</sub> =3V, R <sub>L</sub> =16Ω, (R <sub>f</sub> =75k)	1.0	1.15	1.25	Vdc
	VO(6)	V <sub>CC</sub> = 6V	-	2.65	-	
	VO(12)	V <sub>CC</sub> =12V	-	5.65	-	
Output Level	VOH VOL	High I <sub>out</sub> =-75mA, 2V ≤ V <sub>CC</sub> ≤ 16V Low I <sub>out</sub> = 75mA, 2V ≤ V <sub>CC</sub> ≤ 16V	- -	V <sub>CC</sub> -1 0.16	- -	Vdc
Output DC Offset Voltage (VO1-VO2)	ΔVo	V <sub>CC</sub> =6V, R <sub>f</sub> =75kΩ, R <sub>L</sub> =32Ω	-30	0	+30	mV
Input Bias Current	I <sub>IB</sub>	V <sub>in</sub> (V <sub>CC</sub> =6V)	-	-100	-200	nA
Equivalent Resistance	R <sub>FC1</sub>	FC1(V <sub>CC</sub> =6V)	100	150	220	kΩ
	R <sub>FC2</sub>	FC2(V <sub>CC</sub> =6V)	18	25	40	
<b>Chip Disable(Pin1)</b>						
Input Voltage	V <sub>IL</sub>	Low	-	-	0.8	Vdc
	V <sub>IH</sub>	High	2.0	-	-	
Input Resistance	R <sub>CD</sub>	V <sub>CC</sub> = V <sub>CD</sub> =16V	50	90	175	kΩ
<b>Power Supply</b>						
Power Supply Current	ICC3	V <sub>CC</sub> = 3V, R <sub>L</sub> =∞, CD=0.8V	-	2.7	4.0	mA
	ICC16	V <sub>CC</sub> =16V, R <sub>L</sub> =∞, CD=0.8V	-	3.3	5.0	mA
	ICCD	V <sub>CC</sub> = 3V, R <sub>L</sub> =∞, CD=2.0V	-	65	100	uA

Note: Currents into a pin are positive, currents out of a pin are negative.

## Pin Function Description

Symbol	Pin	Description
CD	1	Chip Disable-Digital input. A Logic "0" (<0.8V) sets normal operation. A Logic "1" ( $\geq 2V$ ) sets the power down mode. Input impedance is nominally 90k $\Omega$ .
FC2	2	A capacitor at this pin increases power supply rejection, and affects turn-on time. This pin can be left open if the capacitor at FC1 is sufficient.
FC1	3	Analog ground for the amplifiers. A 1.0uF capacitor at this pin (with a 5.0uF capacitor at Pin 2) provides (typically) 52dB of power supply rejection. Turn-on time of the circuit is affected by the capacitor on this pin. This pin can be used as an alternate input.
Vin	4	Amplifier input. This input capacitor and resistor set low frequency rolloff and input impedance. The feedback resistor is connected to this pin and VO1.
VO1	5	Amplifier Output #1. The dc level is $\approx (V_{CC} - 0.7)/2$ .
VCC	6	DC supply voltage (+2V to +16V) is applied to this pin.
GND	7	Ground pin for the entire circuit.
VO2	8	Amplifier Output #2. This signal is equal in amplitude, but 180° out-of-phase with that at VO1. The dc level is $\approx (V_{CC} - 0.7)/2$ .

## Typical Temperature Performance (-20°C < TA < +70°C)

Function	Typical Change	Units
Input Bias Current (@ Vin)	$\pm 40$	pA/°C
Total Harmonic Distortion(VCC=6V, RL=32 $\Omega$ Pout=125mW, f=1kHz)	+0.003	%/°C
Power Supply Current (VCC=3V, RL= $\infty$ , CD=0V) (VCC=3V, RL= $\infty$ , CD=2V)	-0.25 -0.03	uA/°C

## Design Guidelines

### General

The GPC34119 is a low power audio amplifier capable of low voltage operation ( $V_{CC} = 2.0 V$  minimum) such as that encountered in line-powered speakerphones. The circuit provides a differential output ( $V_{O1}$ - $V_{O2}$ ) to the speaker to maximize the available voltage swing at low voltages. The differential gain is set by two external resistors. Pins FC1 and FC2 allow controlling the amount of power supply and noise rejection, as well as providing alternate inputs to the amplifiers. The CD pin permits powering down the IC for muting purposes and to conserve power.

### Amplifiers

Referring to the block diagram, the internal configuration consists of two identical operational amplifiers. Amplifier # 1 has an open loop gain of  $\geq 80$  dB (at  $f \leq 100$  Hz), and the closed loop gain is set by external resistor  $R_f$  and  $R_i$ . The amplifier is unity gain stable, and has a unity gain frequency of approximately 1.5 MHz. In order to adequately cover the telephone voice band (300 Hz to 3400 Hz), a maximum closed loop gain of 46 is recommended. Amplifier #2 is internally set to a gain of -1.0(0dB).

The outputs of both amplifiers are capable of sourcing and sinking a peak current of 200 mA. The outputs can typically swing to within  $\approx 0.4 V$  above ground, and to with  $\approx 1.3 V$  below  $V_{CC}$ , at the maximum current. See Figures 17 and 18 for  $V_{OH}$  and  $V_{OL}$  curves.

The output dc offset voltage ( $V_{O1}$ - $V_{O2}$ ) is primarily a function of the feedback resistor ( $R_f$ ), and secondarily due to the amplifiers' input offset voltages. The input offset voltage of the two amplifiers will generally be similar for a particular IC, and therefore nearly cancel each other at the outputs. Amplifier #1's bias current, however, flows out of  $V_{in}$  (Pin 4) and through  $R_f$ , forcing  $V_{O1}$  to shift negative by an amount equal to  $[R_f \times I_{IB}]$ .  $V_{O2}$  is shifted positive an equal amount. The output offset voltage, specified in the Electrical Characteristics, is measured with the feedback resistor shown in the Typical Application Circuit, and therefore takes into account the bias current as well as internal offset voltages of the amplifiers. The bias current is constant with respect to  $V_{CC}$ .

### FC1 and FC2

Power supply rejection is provided by the capacitors ( $C_1$  and  $C_2$  in the Typical Application Circuit) at FC1 and FC2.  $C_2$  is somewhat dominant at low frequencies, while  $C_1$  is dominant at high frequencies, as shown in the graphs of Figures 4 to 7. The required values of  $C_1$  and  $C_2$  depend on the conditions of each application. A line powered speakerphone, for example, will require more filtering than a circuit powered by a well regulated power supply. The amount of rejection is a function of the capacitors, and the equivalent impedance looking into FC1 and FC2 (listed in the Electrical Characteristics as  $R_{FC1}$  and  $R_{FC2}$ ).

In addition to providing filtering,  $C_1$  and  $C_2$  also affect the turn-on time of the circuit at power-up, since the two capacitors must charge up through the internal 50 k and 125 k $\Omega$  resistors. The graph of Figure 1 indicates the turn-on time upon application of  $V_{CC}$  of + 6.0 V. The turn-on time is  $\approx 60\%$  longer for  $V_{CC} = 3.0 V$ , and  $\approx 20\%$  less for  $V_{CC} = 9.0V$ . Turn-off time is < 10 us upon removal of  $V_{CC}$ .

### Chip Disable

The Chip Disable (Pin 1) can be used to power down the IC to conserve power, or for muting, or both. When at a Logic "0" (0 V to 0.8 V), the GP34119 is enabled for normal operation. When Pin 1 is at a Logic "1" (2.0 V to Vcc V), the IC is disabled. If Pin 1 is open, that is equivalent to a Logic "0", although good design practice dictates that an input should never be left open. Input impedance at Pin 1 is a nominal 90 k $\Omega$ . The power supply current (when disabled) is shown in Figure 19.

Muting, defined as the change in differential gain from normal operation to muted operation, is in excess of 70 dB. The turn-off time of the audio output, from the application of the CD signal, is <2.0 us, and turn on-time is 12 ms-15 ms. Both times are independent of C1,C2, and Vcc.

When the GP34119 is disabled, the voltages at FC1 and FC2 do not change as they are powered from Vcc. The outputs, Vo1 and Vo2, change to a high impedance condition, removing the signal from the speaker. If signals from other sources are to be applied to the outputs (while disabled), they must be within the range of Vcc and Ground.

### Power Dissipation

Figures 8 to 10 indicate the device dissipation (within the IC) for various combinations of Vcc, RL, and load power. The maximum power which can safely be dissipated within the GP34119 is found from the following equation:  $P_D = (140^{\circ}\text{C}-T_A)/\theta_{JA}$  where  $T_A$  is the ambient temperature; and  $\theta_{JA}$  is the package thermal resistance (100 $^{\circ}\text{C}/\text{W}$  for the standard DIP package.)

The power dissipated within the GP34119, in a given application, is found from the following equation:

$P_D = (V_{CC} \times I_{CC}) + (I_{RMS} \times V_{CC}) - (R_L \times I_{RMS}^2)$  where  $I_{CC}$  is obtained from Figure 19; and  $I_{RMS}$  is the RMS current at the load; and  $R_L$  is the load resistance.

Figures 8 to 10, along with Figures 11 to 13 (distortion curves), and a peak working load current of  $\pm 200$  mA, define the operating range for the GP34119. The operating range is further defined in terms of allowable load power in Figure 14 for loads of 8.0 $\Omega$ , 16 $\Omega$  and 32 $\Omega$ . The left (ascending) portion of each of the three curves is defined by the power level at which 10% distortion occurs. The center flat portion of each curve is defined by the maximum output current capability of the GP34119. The right (descending) portion of each curve is defined by the maximum internal power dissipation of the IC at 25 $^{\circ}\text{C}$ . At higher ambient temperatures, the maximum load power must be reduced according to the above equations. Operating the device beyond the current and junction temperature limits will degrade long term reliability.

### Layout Considerations

Normally a snubber is not needed at the output of the GP34119, unlike many other audio amplifiers. However, the PC board layout, stray capacitances, and the manner in which the speaker wires are configured, may dictate otherwise. Generally, the speaker wires should be twisted tightly, and not more than a few inches in length.

## Characteristics Curve

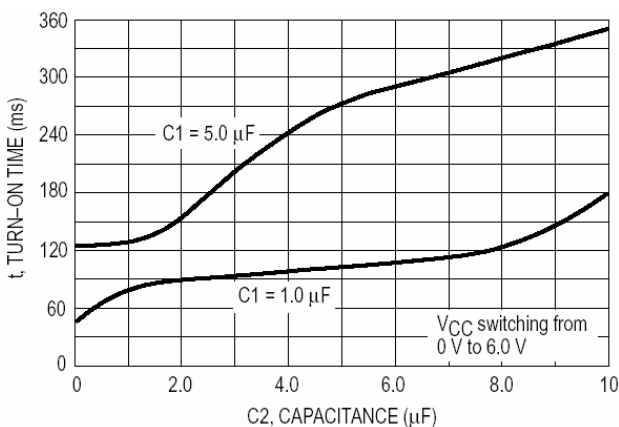

**Fig 1. Turn-On Time versus C1, C2 at Power-On**

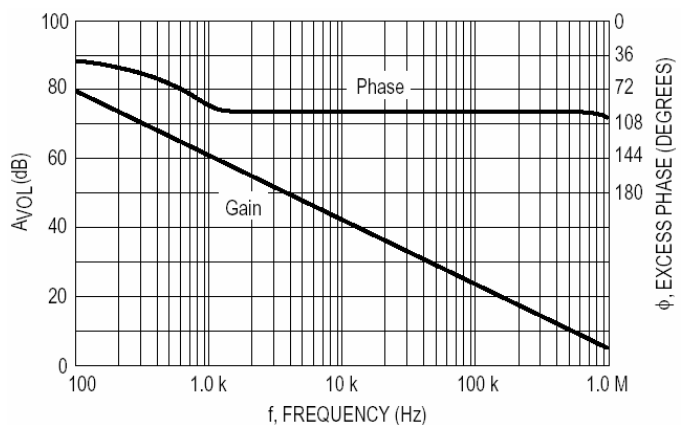

**Fig 2. Amplifier #1 Open Loop Gain and Phase**

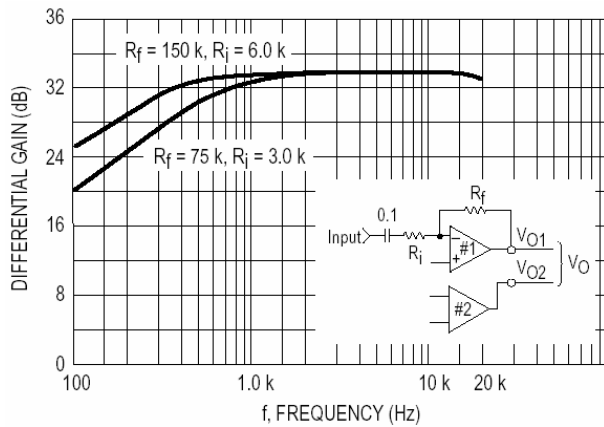

**Fig 3. Differential Gain versus Frequency**

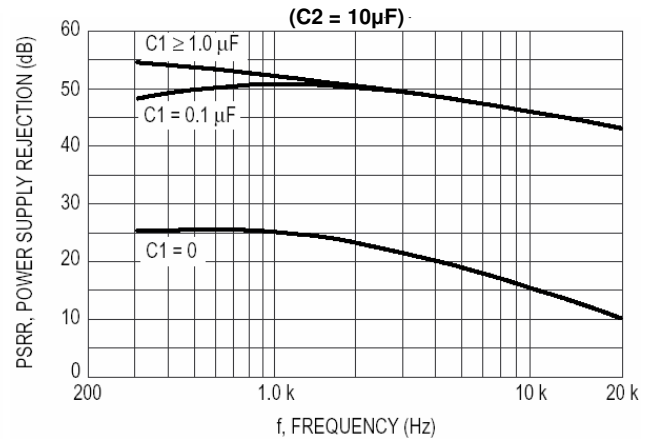

**Fig 4. Power Supply Rejection versus Frequency**

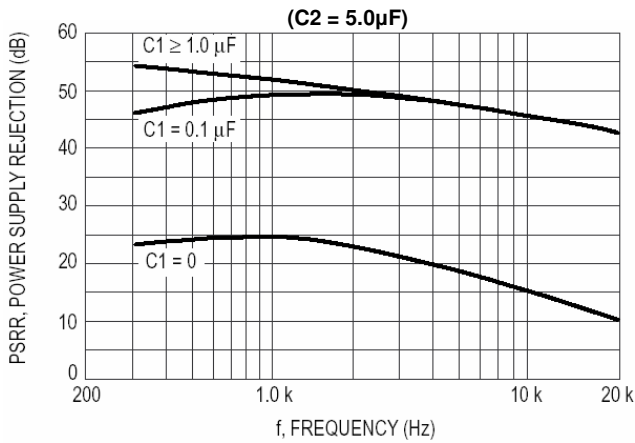

**Fig 5. Power Supply Rejection versus Frequency**

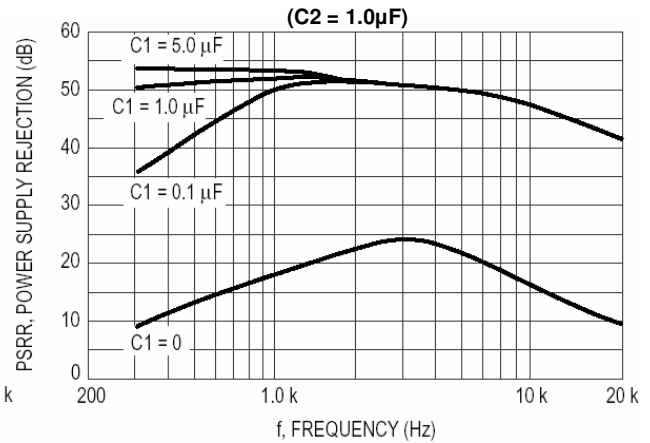

**Fig 6. Power Supply Rejection versus Frequency**

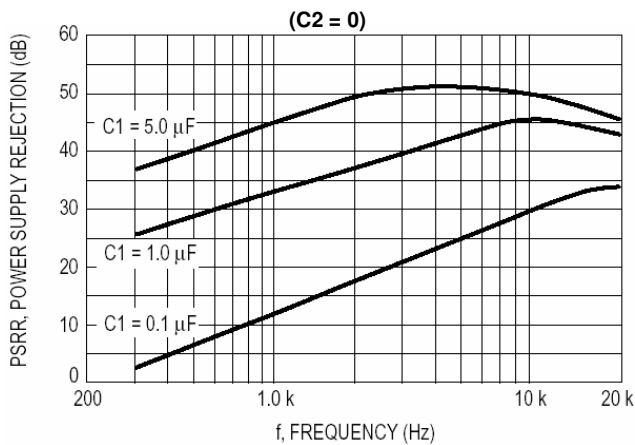

**Fig 7. Power Supply Rejection versus Frequency**

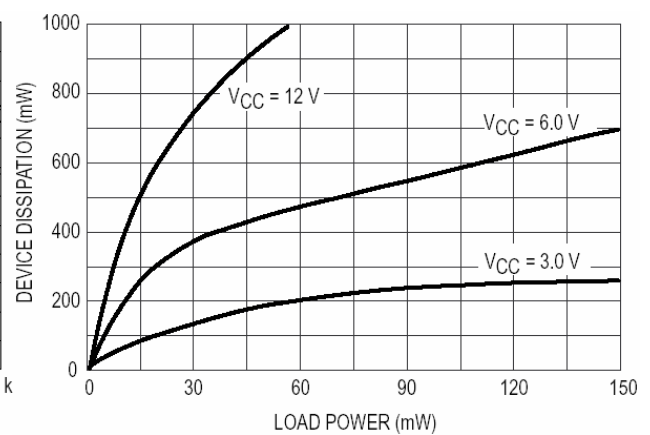

**Fig 8. Device Dissipation, 8.0Ω Load**

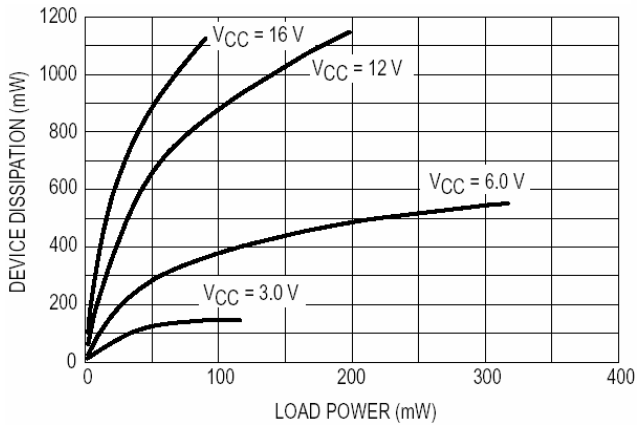

**Fig 9. Device Dissipation, 16 Ω Load**

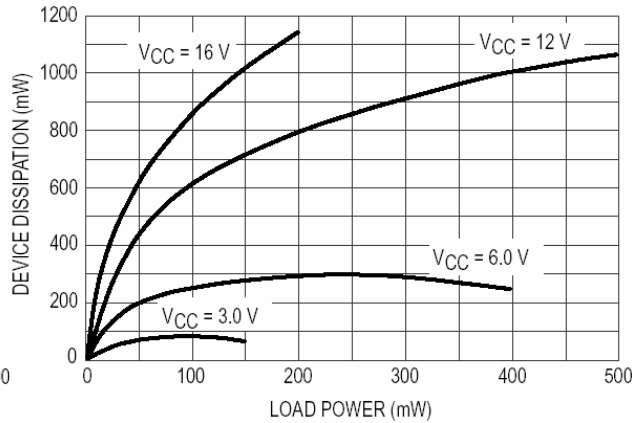

**Fig 10. Device Dissipation, 32 Ω Load**

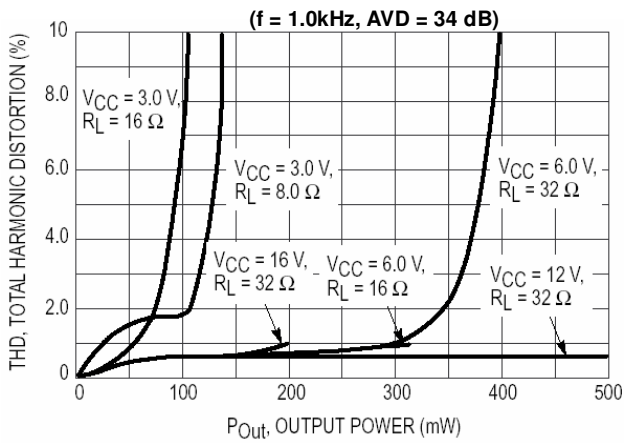

**Fig 11. Distortion versus Power**

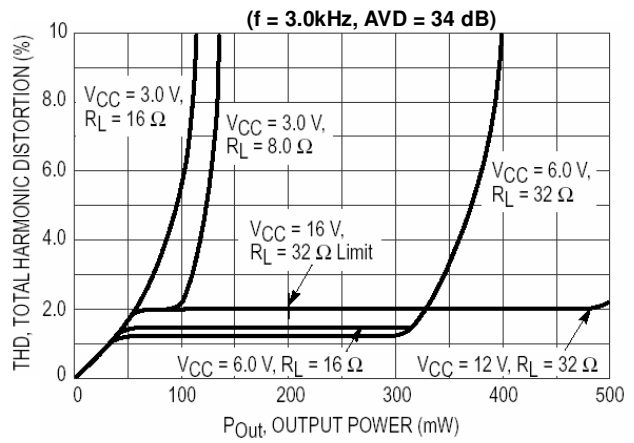

**Fig 12. Distortion versus Power**

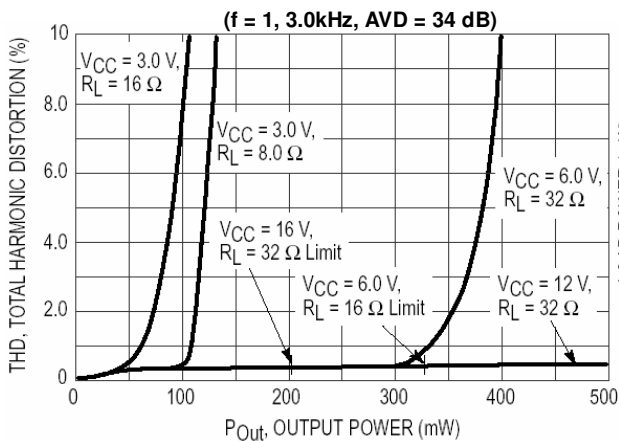

**Fig 13. Distortion versus Power**

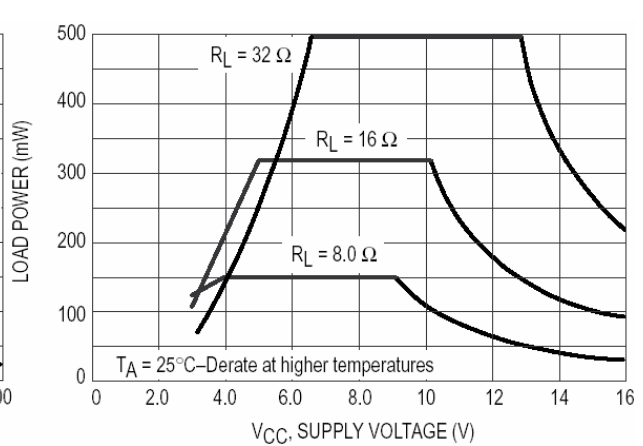

**Fig 14. Maximum Allowable Load Power**

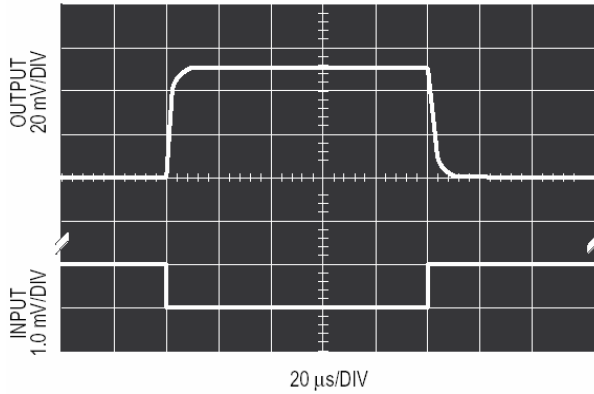

**Fig 15. Small Signal Response**

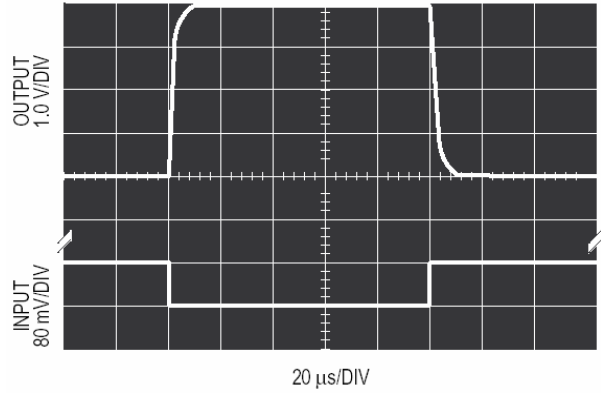

**Fig 16. Large Signal Response**

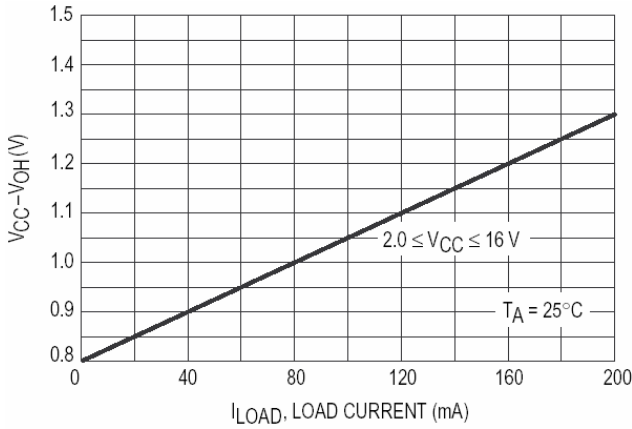

**Fig 17.  $V_{CC} - V_{OH}$  @  $VO_1, VO_2$  versus Load Current**

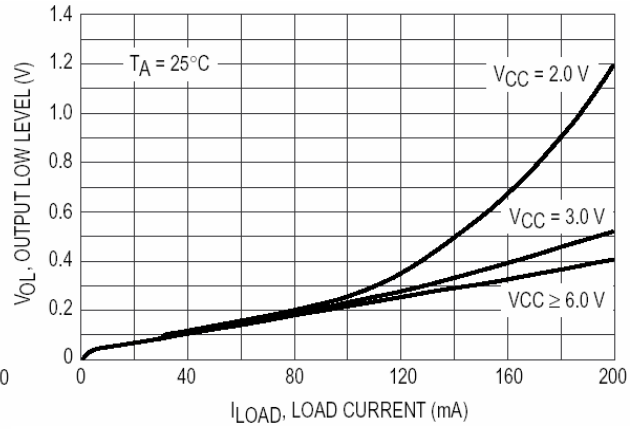

**Fig 18.  $V_{OL}$  @  $VO_1, VO_2$  versus Load Current**

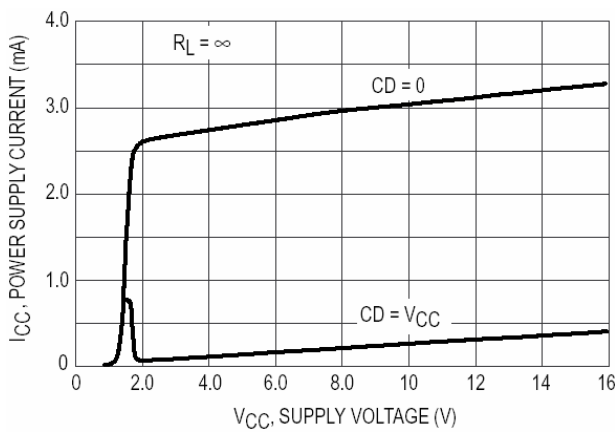

**Fig 19. Power Supply Current**

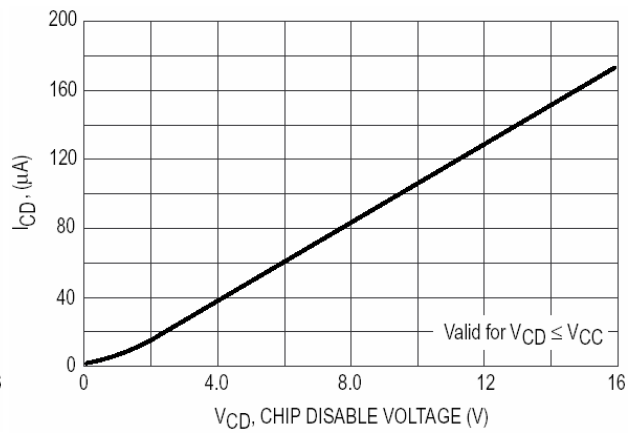

**Fig 20. Input Characteristics @  $CD$  (Pin 1)**

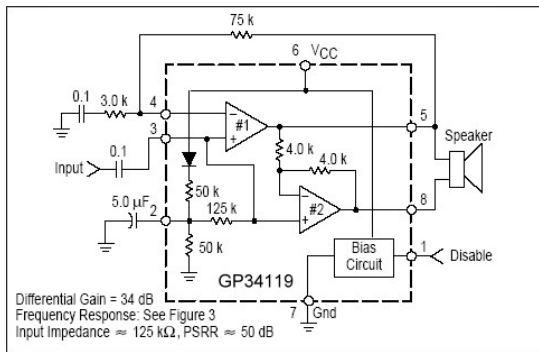

**Fig 21. Audio Amplifier with High Input Impedance**

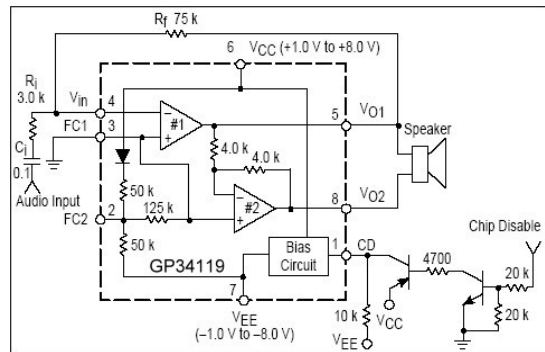

**Fig 22. Split Supply Operation**

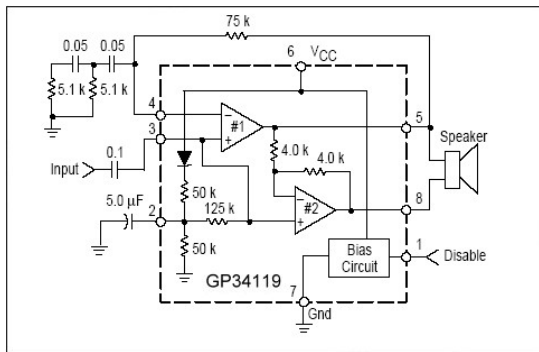

**Fig 23. Audio Amplifier with Bass Suppression**

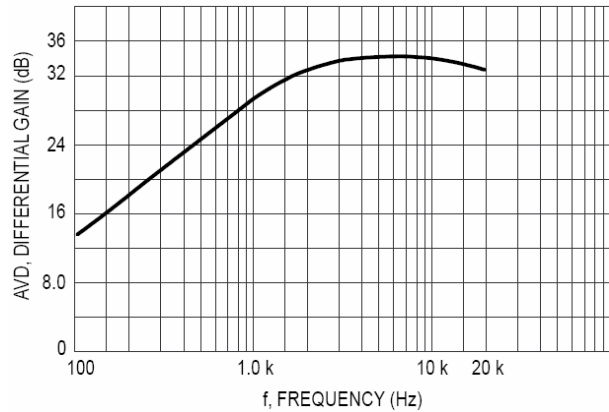

**Fig 24. Frequency Response of Fig 23**

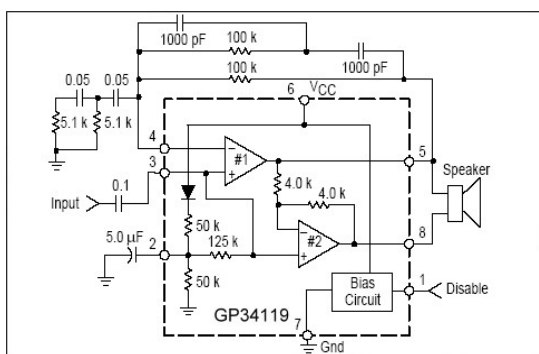

**Fig 25. Audio Amplifier with Bandpass**

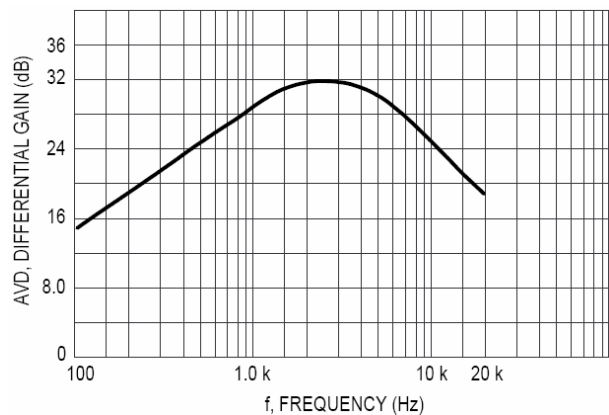

**Fig 26. Frequency Response of Fig 25**

**Important Notice:**

- All rights are reserved. Reproduction in whole or in part is prohibited without the prior written approval of GTM.
- GTM reserves the right to make changes to its products without notice.
- GTM semiconductor products are not warranted to be suitable for use in life-support Applications, or systems.
- GTM assumes no liability for any consequence of customer product design, infringement of patents, or application assistance.

**Head Office And Factory:**

- **Taiwan:** No. 17-1 Tatung Rd. Fu Kou Hsin-Chu Industrial Park, Hsin-Chu, Taiwan, R. O. C.
- TEL : 886-3-597-7061 FAX : 886-3-597-9220, 597-0785
- **China:** (201203) No.255, Jang-Jiang Tsai-Lueng RD. , Pu-Dung-Hsin District, Shang-Hai City, China
- TEL : 86-21-5895-7671 ~ 4 FAX : 86-21-38950165