

FEATURES

- 8 programmable resistors
- 1 programmable switch
- conforms to communication standard for programmable devices P/N 30381-000

DESCRIPTION

The GP522 is a single memory controller chip, designed as an array of resistors used to control functions of any signal processing integrated circuit. Controller consists of eight digitally programmable resistors and one switch. The GP522 can be programmed by any programmer supporting communication standard for programmable devices P/N 30381-00.

PACKAGING

Chip (169 x 81 mils)
 Au Bump

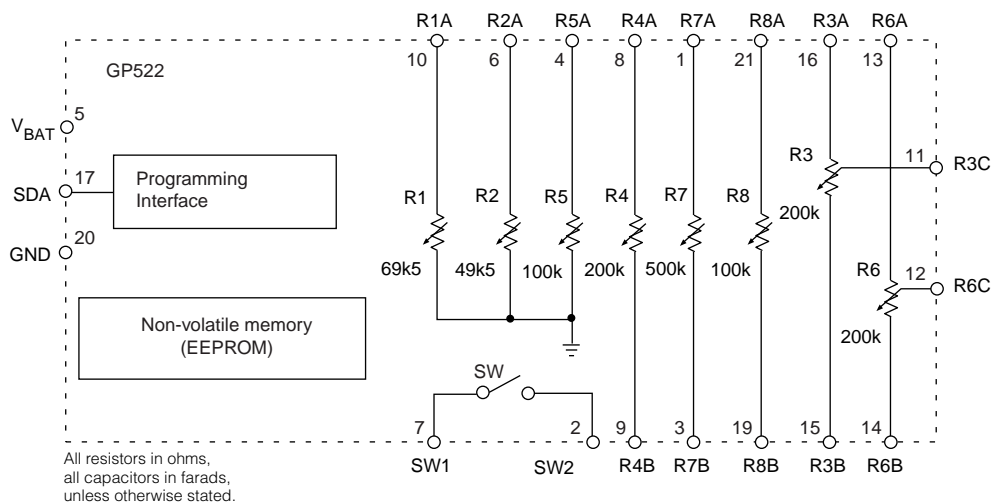

BLOCK DIAGRAM

ABSOLUTE MAXIMUM RATINGS

PARAMETER	VALUE
Supply Voltage	1.4V DC
Minimum Voltage on any pad	-0.5V DC
Maximum Voltage on SDA pad	17.5V DC
Maximum Voltage on any other pad	V_{BAT}
ESD rating of SDA pad	$\pm 1500V$
ESD rating of any other pad	$\pm 2000V$
Operating Temperature Range	0°C to 40°C
Storage Temperature Range	-40°C to 70°C

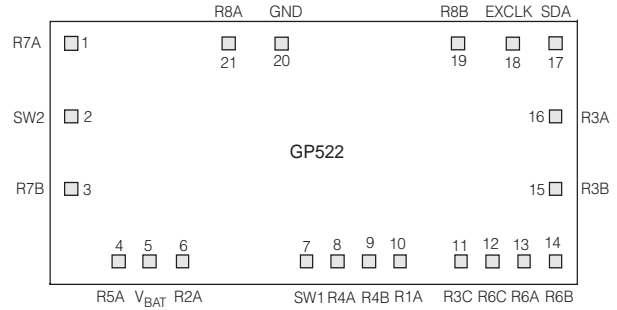
PAD CONNECTION

CAUTION
ELECTROSTATIC
SENSITIVE DEVICES
DO NOT OPEN PACKAGES OR HANDLE
EXCEPT AT A STATIC-FREE WORKSTATION



CAUTION
ULTRA VIOLET RADIATION SENSITIVE

ELECTRICAL CHARACTERISTICS Conditions: Temperature 25°C.

PARAMETER	SYMBOL	CONDITIONS	MIN	TYP	MAX	UNITS
Supply Voltage	V_{BAT}		1.1	1.25	1.4	V
Supply Current	I_{DD}		40	45	50	μA
	I_{DDq}	Current reference disabled	-	5	-	μA
EEPROM read/write cycles			1000	-	-	cycles
Clock Frequency	f_{CLOCK}	Calibrated value	120	150	225	kHz
SW Resistance (ON)	R_{ON}		-	-	1	$k\Omega$
SW Leakage (OFF)	I_{LEAK}		-	-	1	μA
Data 0 - Input Current		Write	-20%	-60	+20%	μA
Data 0 - Input Current		Read	-40%	-30	+40%	μA
Data 1 - Input Current		Write	-20%	+60	+20%	μA
Data 1 - Input Current		Read	-40%	+30	+40%	μA
PROGRAMMING OPERATION						
Programming Voltage	V_{PRGM}	Fig. 1	15.5	16	16.5	V
Programming Current	I_{PRGM}		-	100	-	μA
Data to Program Pulse	$t_{PDATAPRG}$	Fig. 1	1	-	10	ms
Program Pulse Rise Time	$t_{PRGRISE}$	Fig. 1	1	-	2	ms
Program Pulse Fall Time	$t_{PRGFALL}$	Fig. 1	0.5	-	1.5	ms
Pulse Width	t_{WPR}	Fig. 1	5	-	10	ms
Data Bit Cycle	t_{CYCLE}		0.85	1.28	1.60	ms
Synchronization	t_{SYNC}		-	$t_{CYCLE}/6$	-	

NOTE: During Power Down resistors go to the maximum values.

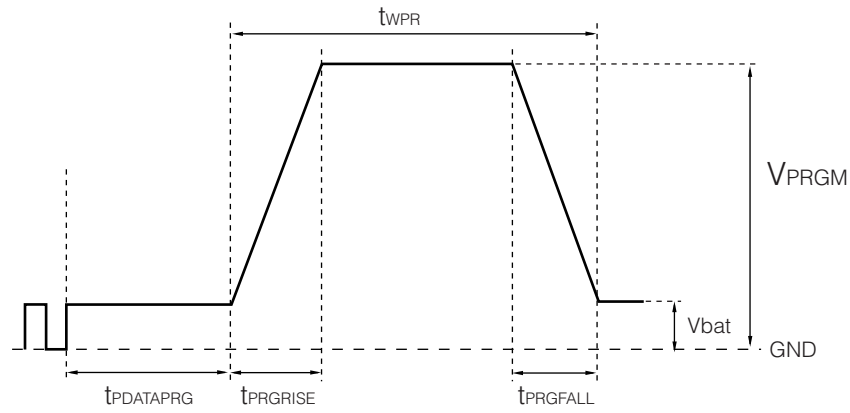

Fig. 1 Programmer Program Pulse Timing

R1 [CROSSOVER] = 69.5kΩ ± 25%
 DC referenced to V_{SS}, AC = 0,0mV_{RMS}.

TAP	BIT 1	BIT 2	BIT 3	BIT 4	RATIOMETRIC VALUE (%)	RATIOMETRIC TOLERANCE (±%)	NOMINAL TAP VALUE	UNITS
0	0	0	0	0	100.0	N/A	69.5	kΩ
1	0	0	0	1	86.33	7	60.0	kΩ
2	0	0	1	0	74.10	7	51.5	kΩ
3	0	0	1	1	63.31	7	44.0	kΩ
4	0	1	0	0	55.31	7	38.4	kΩ
5	0	1	0	1	44.87	9	31.2	kΩ
6	0	1	1	0	38.08	9	27.2	kΩ
7	0	1	1	1	30.86	9	21.4	kΩ
8	1	0	0	0	26.12	12	18.2	kΩ
9	1	0	0	1	21.58	12	15.0	kΩ
10	1	0	1	0	15.93	12	11.1	kΩ
11	1	0	1	1	12.40	16	8.62	kΩ
12	1	1	0	0	9.37	22	6.51	kΩ
13	1	1	0	1	6.25	23	4.35	kΩ
14	1	1	1	0	3.95	28	2.75	kΩ
15	1	1	1	1	N/A	N/A	0.5 MAX	kΩ

R2 [THRESHOLD] = $49.5\text{k}\Omega \pm 25\%$
 DC referenced to V_{SS} , AC = $0, 0\text{mV}_{RMS}$.

TAP	BIT 5	BIT 6	BIT 7	BIT 8	RATIOMETRIC VALUE (%)	RATIOMETRIC TOLERANCE ($\pm\%$)	NOMINAL TAP VALUE	UNITS
0	0	0	0	0	100.00	N/A	49.5	k Ω
1	0	0	0	1	82.64	7	40.9	k Ω
2	0	0	1	0	68.62	9	34.0	k Ω
3	0	0	1	1	54.75	9	27.1	k Ω
4	0	1	0	0	46.06	9	22.8	k Ω
5	0	1	0	1	36.02	9	17.8	k Ω
6	0	1	1	0	30.38	11	15.0	k Ω
7	0	1	1	1	24.64	11	12.2	k Ω
8	1	0	0	0	20.27	12	10.0	k Ω
9	1	0	0	1	13.58	16	6.72	k Ω
10	1	0	1	0	10.91	23	5.40	k Ω
11	1	0	1	1	7.47	16	3.70	k Ω
12	1	1	0	0	5.88	20	2.91	k Ω
13	1	1	0	1	3.88	22	1.92	k Ω
14	1	1	1	0	2.42	32	1.20	k Ω
15	1	1	1	1	N/A	N/A	0.15 MAX	k Ω

R3 [LOW RATIO] = $100\text{k}\Omega \pm 40\%$
 DC referenced to $V_{SS} + V_{be}$, AC = $100, 100\text{mV}_{RMS}$.

TAP	BIT 9	BIT 10	BIT 11	BIT 12	RATIOMETRIC VALUE (%)	RATIOMETRIC TOLERANCE ($\pm\%$)	NOMINAL TAP VALUE	UNITS
0	0	0	0	0	N/A	N/A	0.5 MAX	k Ω
1	0	0	0	1	7.14	14	14.3	k Ω
2	0	0	1	0	13.67	11	27.3	k Ω
3	0	0	1	1	19.509	9	39.0	k Ω
4	0	1	0	0	27.37	7	54.7	k Ω
5	0	1	0	1	33.40	7	66.8	k Ω
6	0	1	1	0	40.40	7	80.8	k Ω
7	0	1	1	1	46.70	7	93.4	k Ω
8	1	0	0	0	53.50	7	107	k Ω
9	1	0	0	1	59.40	7	119	k Ω
10	1	0	1	0	67.17	7	134	k Ω
11	1	0	1	1	73.50	7	147	k Ω
12	1	1	0	0	80.00	7	160	k Ω
13	1	1	0	1	86.50	7	173	k Ω
14	1	1	1	0	93.50	7	187	k Ω
15	1	1	1	1	100.00	N/A	200	k Ω

R4 [LOW CUT] = 200kΩ ± 25%
 DC referenced to $V_{SS} + 400mV$, AC = 140, 140mV_{RMS}

TAP	BIT 13	BIT 14	BIT 15	BIT 16	RATIOMETRIC VALUE (%)	RATIOMETRIC TOLERANCE (±%)	NOMINAL TAP VALUE	UNITS
0	0	0	0	0	100.00	N/A	200	kΩ
1	0	0	0	1	71.71	7	143	kΩ
2	0	0	1	0	50.00	7	102	kΩ
3	0	0	1	1	35.76	7	71.5	kΩ
4	0	1	0	0	24.40	9	48.8	kΩ
5	0	1	0	1	16.40	9	32.8	kΩ
6	0	1	1	0	11.11	11	22.2	kΩ
7	0	1	1	1	6.93	11	13.9	kΩ
8	1	0	0	0	6.80	7	13.6	kΩ
9	1	0	0	1	5.30	14	10.6	kΩ
10	1	0	1	0	3.78	14	7.57	kΩ
11	1	0	1	1	2.55	17	5.10	kΩ
12	1	1	0	0	1.98	17	3.95	kΩ
13	1	1	0	1	1.46	17	2.91	kΩ
14	1	1	1	0	1.18	22	2.37	kΩ
15	1	1	1	1	N/A	N/A	0.14 MAX	kΩ

R5 [OUTPUT] = 100kΩ ± 25%
 DC referenced to V_{SS} , AC = 0,0mV_{RMS}

TAP	BIT 17	BIT 18	BIT 19	BIT 20	RATIOMETRIC VALUE (%)	RATIOMETRIC TOLERANCE (±%)	NOMINAL TAP VALUE	UNITS
0	0	0	0	0	100.00	N/A	100	kΩ
1	0	0	0	1	85.26	7	85.3	kΩ
2	0	0	1	0	72.07	7	72.1	kΩ
3	0	0	1	1	60.00	7	60.0	kΩ
4	0	1	0	0	50.00	7	50.0	kΩ
5	0	1	0	1	42.00	7	42.0	kΩ
6	0	1	1	0	36.50	7	36.5	kΩ
7	0	1	1	1	30.30	9	30.3	kΩ
8	1	0	0	0	25.63	9	25.6	kΩ
9	1	0	0	1	20.58	11	20.6	kΩ
10	1	0	1	0	18.30	11	18.3	kΩ
11	1	0	1	1	15.91	11	15.9	kΩ
12	1	1	0	0	13.74	11	13.7	kΩ
13	1	1	0	1	10.58	16	10.6	kΩ
14	1	1	1	0	9.38	16	9.38	kΩ
15	1	1	1	1	7.90	N/A	7.90	kΩ

R6 [HIGH RATIO] = 200kΩ ± 40%
 DC referenced to $V_{SS} + V_{be}$, AC = 1000, 100mV_{RMS}.

TAP	BIT 21	BIT 22	BIT 23	BIT 24	RATIOMETRIC VALUE (%)	RATIOMETRIC TOLERANCE (±%)	NOMINAL TAP VALUE	UNITS
0	0	0	0	0	N/A	N/A	0.5 MAX	kΩ
1	0	0	0	1	7.14	15	14.3	kΩ
2	0	0	1	0	13.67	10	27.3	kΩ
3	0	0	1	1	19.60	7	39.2	kΩ
4	0	1	0	0	27.10	7	54.2	kΩ
5	0	1	0	1	33.40	7	66.8	kΩ
6	0	1	1	0	40.40	7	80.8	kΩ
7	0	1	1	1	47.17	7	94.3	kΩ
8	1	0	0	0	53.50	7	107	kΩ
9	1	0	0	1	60.00	7	120	kΩ
10	1	0	1	0	67.17	7	134	kΩ
11	1	0	1	1	73.50	7	147	kΩ
12	1	1	0	0	80.00	7	160	kΩ
13	1	1	0	1	86.50	7	173	kΩ
14	1	1	1	0	93.50	7	187	kΩ
15	1	1	1	1	100.00	N/A	200	kΩ

R8 [HIGH CUT] = 100kΩ ± 25%
 DC referenced to V_{BAT} , AC = 880, 880mV_{RMS}.

TAP	BIT 30	BIT 31	BIT 32	BIT 33	RATIOMETRIC VALUE (%)	RATIOMETRIC TOLERANCE (±%)	NOMINAL TAP VALUE	UNITS
0	0	0	0	0	100	N/A	100	kΩ
1	0	0	0	1	12.06	12	12.1	kΩ
2	0	0	1	0	7.17	13	7.17	kΩ
3	0	0	1	1	6.16	12	6.16	kΩ
4	0	1	0	0	4.22	12	4.22	kΩ
5	0	1	0	1	3.65	12	3.65	kΩ
6	0	1	1	0	2.62	12	2.62	kΩ
7	0	1	1	1	2.28	12	2.28	kΩ
8	1	0	0	0	1.88	12	1.88	kΩ
9	1	0	0	1	1.68	12	1.68	kΩ
10	1	0	1	0	1.23	12	1.23	kΩ
11	1	0	1	1	0.90	12	0.90	kΩ
12	1	1	0	0	0.71	12	0.71	kΩ
13	1	1	0	1	0.56	12	0.56	kΩ
14	1	1	1	0	0.44	14	0.44	kΩ
15	1	1	1	1	N/A	N/A	0.14 MAX	kΩ

R7 [GAIN] = 500kΩ ± 25%
 DC referenced to V_{SS} + V_{be}, AC = 0, 210mV_{RMS}.

TAP	BIT 25	BIT 26	BIT 27	BIT 28	BIT 29	RATIOMETRIC VALUE (%)	RATIOMETRIC TOLERANCE (±%)	NOMINAL TAP VALUE	UNITS
0	0	0	0	0	0	100.00	N/A	500	kΩ
1	0	0	0	0	1	89.97	7	450	kΩ
2	0	0	0	1	0	81.43	7	407	kΩ
3	0	0	0	1	1	75.02	7	375	kΩ
4	0	0	1	0	0	68.34	7	342	kΩ
5	0	0	1	0	1	60.88	7	304	kΩ
6	0	0	1	1	0	55.31	7	277	kΩ
7	0	0	1	1	1	45.29	7	226	kΩ
8	0	1	0	0	0	35.00	7	175	kΩ
9	0	1	0	0	1	28.40	7	142	kΩ
10	0	1	0	1	0	17.32	7	86.6	kΩ
11	0	1	0	1	1	15.60	7	78.0	kΩ
12	0	1	1	0	0	8.67	10	43.4	kΩ
13	0	1	1	0	1	6.40	10	32.0	kΩ
14	0	1	1	1	0	4.20	10	21.0	kΩ
15	0	1	1	1	1	3.10	12	15.5	kΩ
16	1	0	0	0	0	2.31	14	11.6	kΩ
17	1	0	0	0	1	1.50	21	7.50	kΩ
18	1	0	0	1	0	1.16	22	5.78	kΩ
19	1	0	0	1	1	0.73	22	3.66	kΩ
20	1	0	1	0	0	0.56	22	2.80	kΩ
21	1	0	1	0	1	0.42	22	2.10	kΩ
22	1	0	1	1	0	0.32	22	1.58	kΩ
23	1	0	1	1	1	N/A	N/A	0.15 MAX	kΩ

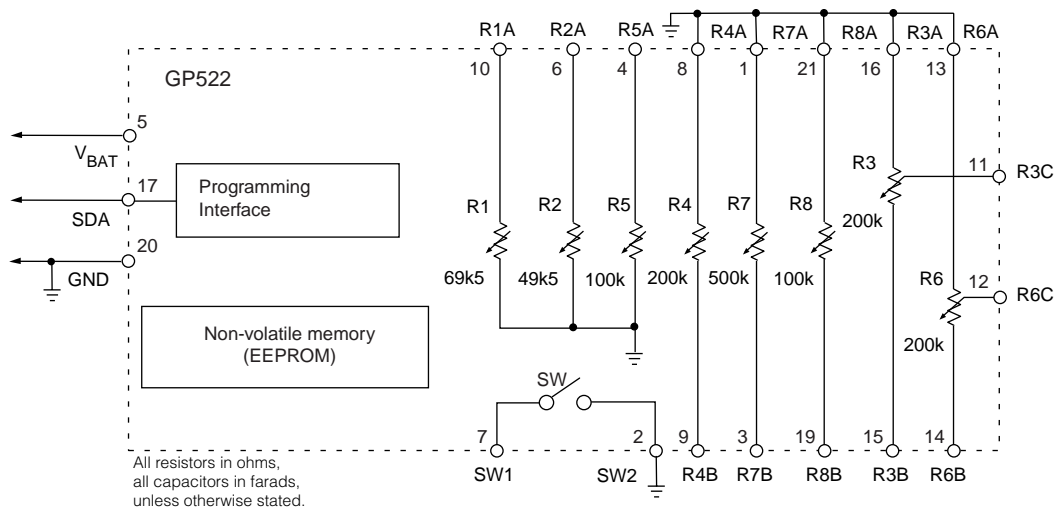
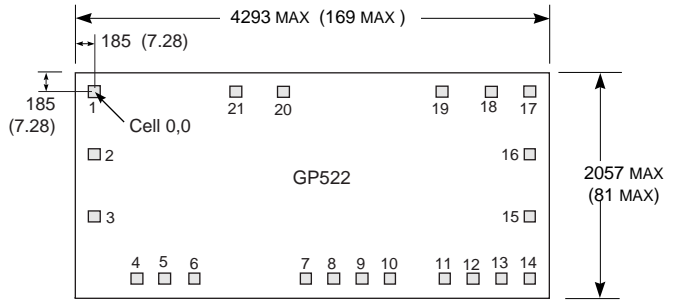

Fig. 2 Production Test Circuit

PAD LAYOUT

PAD NO.	X	Y
1	0 [0.0]	0 [0.0]
2	564 [22.2]	0 [0.0]
3	1123 [44.2]	0 [0.0]
4	1682 [66.2]	379 [14.9]
5	1682 [66.2]	633 [24.9]
6	1682 [66.2]	900 [35.4]
7	1682 [66.2]	1903 [74.9]
8	1682 [66.2]	2157 [84.9]
9	1682 [66.2]	2411 [94.9]
10	1682 [66.2]	2665 [104.9]
11	1682 [66.2]	3161 [124.4]
12	1682 [66.2]	3415 [134.4]
13	1682 [66.2]	3669 [144.4]
14	1682 [66.2]	3923 [154.4]
15	1123 [44.2]	3923 [154.4]
16	564 [22.2]	3923 [154.4]
17	0 [0.0]	3923 [154.4]
18	0 [0.0]	3536 [139.2]
19	0 [0.0]	1707 [67.2]
20	0 [0.0]	1276 [50.2]
21	0 [0.0]	3079 [121.2]

CHIP DIMENSIONS



SPECIFICATIONS	
DIE THICKNESS	254µm [10mils] MAX
MIN BOND PAD OPENING	
BUMP SPEC DOCUMENT	

Dimensions are in micrometers.
 Dimensions shown in parenthesis are in mils converted from micrometers, and include minor rounding errors.
 1 mil = 25.4µm

Attention: The GP522 Controller Chip is visually inspected at an AQL of 0.65% based on MILSTD105E sampling plan, rather than being subjected to 100% visual inspection.

GENNUM CORPORATION

MAILING ADDRESS:
 P.O. Box 489, Stn. A, Burlington, Ontario, Canada L7R 3Y3
 Tel. +1 (905) 632-2996 Fax +1 (905) 632-2814
 SHIPPING ADDRESS:
 970 Fraser Drive, Burlington, Ontario, Canada L7L 5P5

GENNUM JAPAN CORPORATION
 C-101, Miyamae Village, 2-10-42 Miyamae, Suginami-ku, Tokyo 168-0081, Japan
 Tel. +81 (3) 3334-7700 Fax: +81 (3) 3247-8839

REVISION NOTES:
 Corrections to Pad Connection diagram and Electrical Characteristics table.

DOCUMENT IDENTIFICATION:
 PRELIMINARY DATA SHEET
 The product is in a preproduction phase and specifications are subject to change without notice.