

GPC21A3

20KB SOUND CONTROLLER

DEC. 12, 2005

Version 1.1

Table of Contents

	<u>PAGE</u>
1. GENERAL DESCRIPTION	3
2. BLOCK DIAGRAM	3
3. FEATURES	3
4. APPLICATION FIELD	3
5. SIGNAL DESCRIPTIONS	4
6. FUNCTIONAL DESCRIPTIONS	5
6.1. CPU	5
6.2. ROM AREA	5
6.3. RAM AREA	5
6.4. MAP OF MEMORY AND I/Os	5
6.5. I/O PORT CONFIGURATION*	5
6.6. POWER SAVINGS MODE	6
6.7. LOW VOLTAGE RESET	6
6.8. TIMER/COUNTER	7
6.9. SPEECH AND MELODY	7
7. ELECTRICAL SPECIFICATIONS	8
7.1. ABSOLUTE MAXIMUM RATINGS	8
7.2. AC CHARACTERISTICS ($T_A = 25^\circ\text{C}$)	8
7.3. DC CHARACTERISTICS ($V_{DD} = 3.0\text{V}$, $T_A = 25^\circ\text{C}$)	8
7.4. DC CHARACTERISTICS ($V_{DD} = 5.0\text{V}$, $T_A = 25^\circ\text{C}$)	8
7.5. THE RELATIONSHIP BETWEEN THE R_{OSC} AND THE F_{CPU}	9
7.5.1. $V_{DD} = 3.0\text{V}$, $T_A = 25^\circ\text{C}$	9
7.5.2. $V_{DD} = 4.5\text{V}$, $T_A = 25^\circ\text{C}$	9
7.5.3. Frequency vs. temperature	9
7.5.4. Frequency vs. V_{DD}	9
7.5.5. Operating current vs. frequency vs. V_{DD}	9
8. APPLICATION CIRCUITS	10
8.1. APPLICATION CIRCUIT	10
8.2. CURRENT MODE DAC SPEAKER DRIVER	11
9. PACKAGE/PAD LOCATIONS	12
9.1. PAD ASSIGNMENT	12
9.2. ORDERING INFORMATION	12
10. DISCLAIMER	13
11. REVISION HISTORY	14

20KB SOUND CONTROLLER

1. GENERAL DESCRIPTION

The GPC21A3 is a CPU based two-channel speech/melody synthesizer including CMOS 8-bit microprocessor with 69 instructions, 20K-byte ROM for speech and melody data (Speech is compressed by a 4-bit ADPCM with approx. 6 sec speech duration @ 6KHz sampling rate) and 64-byte working SRAM. It includes two Timer/Counters, 10 Software Selectable I/Os, and one 8-bit current D/A output. For audio processing, melody and speech can be mixed into one output. It operates over a wide voltage range of 2.4V - 5.1V and includes Low Voltage Reset function. The Low Voltage Reset automatically resets when the working voltage is less than 2.2V. In addition, GPC21A3 has a Clock Stop mode for power savings. The power savings mode saves the RAM contents, but freezes the oscillator, causing all other chip functions to be inoperative. The Max. CPU clock frequency is 6.0MHz. It has an Instruction Cycle Rate of 2 clock cycles (min.) - 6 clock cycles (max.). The GPC21A3 includes, not only the latest technology, but also the full commitment and technical support of Generalplus.

2. BLOCK DIAGRAM

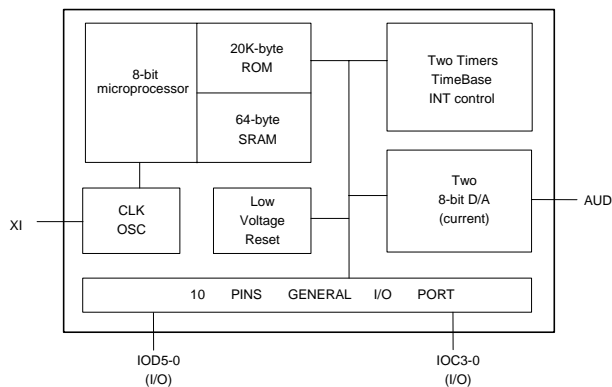

3. FEATURES

- 8-bit microprocessor
- Provides 20K-byte ROM for program and audio data
- 64-byte working SRAM
- Software-based audio processing
- Wide operating voltage: 2.4V - 3.6V @ 4.0MHz
3.6V - 5.5V @ 6.0MHz
- Supports R_{osc} only
- Max. CPU clock: 4.0MHz @ 2.4V - 3.6V
6.0MHz @ 3.6V - 5.5V
- Standby mode (Clock Stop mode) for power savings.
Max. 2μA @ 5.0V
- 500ns instruction cycle time @ 4.0MHz CPU clock
- Provides 10 general I/Os
- Two 12-bit timer/counters
- 6 INT sources
- Key wake-up function
- Approx. 6 sec speech
@ 6KHz sampling rate with 4-bit ADPCM
- One D/A output
- Low Voltage Reset

4. APPLICATION FIELD

- Intelligent education toys
Ex. Pattern to voice (animal, car, color, etc.)
Spelling (English or Chinese)
Math
- High end toy controller
- Talking instrument controller
- General speech synthesizer
- Industrial controller

5. SIGNAL DESCRIPTIONS

Mnemonic	PIN No.	Type	Description
VDD	8	I	Supply voltage input
VSS	1, 7	I	Ground
XI	9	I	Rosc only. (Resistor should be connected to VDD)
RESET	2	I	RESET
TEST	11	I	TEST MODE
AUD	10	O	AUDIO OUTPUT
IOC0	6	I/O	Port C is a 4-bit bi-directional programmable Input / Output port with Pull-high or Open-drain option. As inputs, Port C can be in either the Pure or Pull-high states. As outputs Port C can be a Buffer or Open-drain NMOS type (sink current). IOC1: EXT INT IN IOC2: EXT COUNT IN **See note 1 and 2 below.
IOC1	5	I/O	
IOC2	4	I/O	
IOC3	3	I/O	
IOD0	17	I/O	Port D is a 6-bit bi-directional programmable Input / Output port with Pull-low or Open-drain option. As inputs, Port D can be either Pure or Pull-low states. As outputs, Port D can be either Buffer or Open-drain PMOS type (send current). (Key change, Wake up I/O) **See note 1 and 2 below.
IOD1	16	I/O	
IOD2	15	I/O	
IOD3	14	I/O	
IOD4	13	I/O	
IOD5	12	I/O	

* Refer to GPC Programming Guide for complete information.

**Note: 1). Two input states can be specified; Pure Input, Pull-High or Pull Low.

2). Three output states can be specified as Buffer output, Open Drain PMOS output (send), or Open Drain NMOS output (sink).

6. FUNCTIONAL DESCRIPTIONS

6.1. CPU

The GPC21A3 8-bit microprocessor is a high performance processor equipped with Accumulator, Program Counter, X Register, Stack pointer and Processor Status Register (this is the same as the 6502 instruction structure). GPC21A3 is able to perform with 6.0MHz (max.) depending on the application specifications.

6.2. ROM Area

The GPC21A3 provides a 20K-byte ROM that can be defined as the program area, audio data area, or both.

6.3. RAM Area

The GPC21A3 total RAM consists of 64-bytes (including Stack) at locations from \$C0 through \$FF.

6.4. Map of Memory and I/Os

*I/O PORT:	*MEMORY MAP (From ROM view)
- PORT IOC \$0004	\$00000 Hardware register, I/Os
IOD \$0005	\$000C0 USER RAM and STACK
- I/O CONFIG \$0000	\$00100 UNUSED
\$0001	\$00200 GENERALPLUS TEST PROGRAM
*NMI SOURCE:	\$00600 USER'S PROGRAM & DATA AREA
- INTA (from TIMER A)	\$03FFF DUMMY AREA
*INT SOURCE:	\$07000 USER'S PROGRAM & DATA AREA
- INTA (from TIMER A)	\$07FFF
- INTB (from TIMER B)	
- CPU CLK / 1024	
- CPU CLK / 8192	
- CPU CLK / 65536	
- EXT INT	

6.5. I/O Port Configuration*

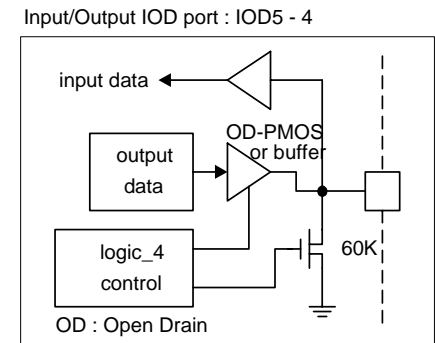
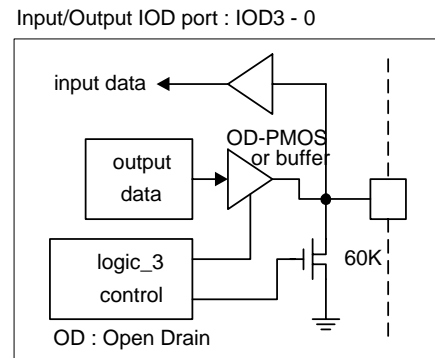
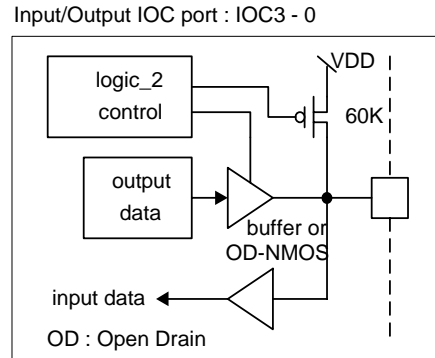

*Values shown are for VDD = 5.0V test conditions only.

6.6. Power Savings Mode

The GPC21A3 provides a power savings mode (Standby mode) for those applications that require very low stand-by current. To enter standby mode, the Wake-Up Register should be enabled and then stop the CPU clock by writing the STOP CLOCK Register. The CPU will then go to the stand-by mode. In such a mode, RAM and I/Os will remain in their previous states until being

awakened. Port IOD7 - 0 is the only wake-up source in the GPC21A3. After the GPC21A3 is awakened, the internal CPU will go to the RESET State ($T_w \geq 65536 \times T_1$) and then continue processing the program. Wakeup Reset will not affect RAM or I/Os (FIG.1).

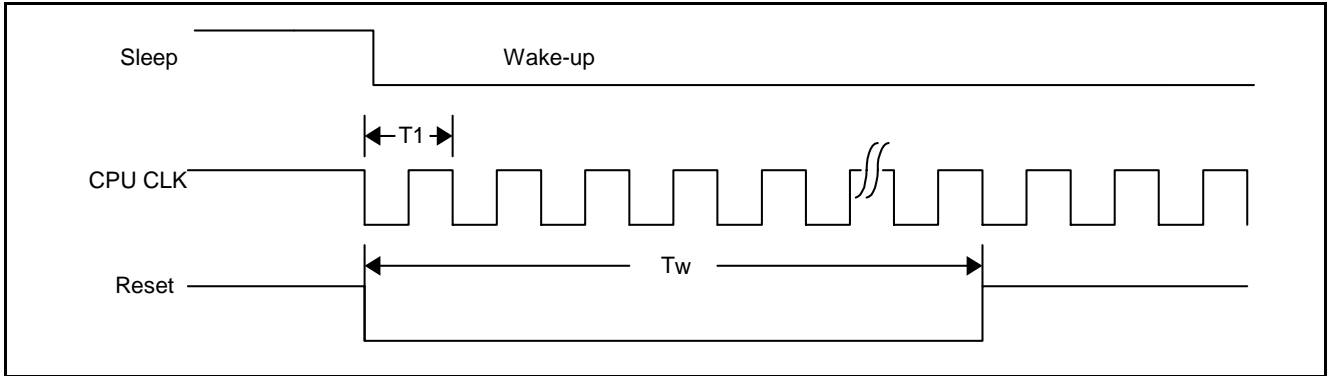

FIG. 1

$T_1 = 1 / (F_{CPU}), T_w \geq 65536 \times T_1$

6.7. Low Voltage Reset

The GPC21A3 includes a Low Voltage Reset (LVR) function. Below the minimum power-supply voltage of 2.2V, the CPU system will become unstable and malfunction. Low Voltage

Reset will reset all functions into the initial operational (stable) state if the VDD power-supply voltage drops below 2.2V (FIG.2).

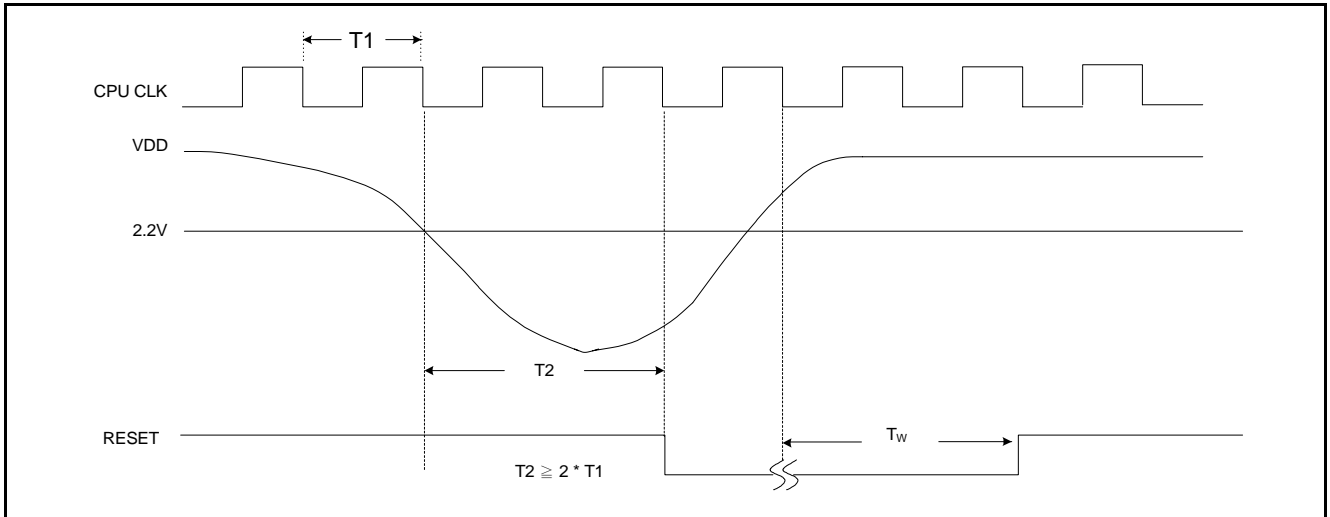

(The LVR function is the same as Power ON Reset or External Reset.)

FIG. 2

6.8. Timer/Counter

The GPC21A3 contains two 12-bit timer/counters, TMA and TMB respectively. TMA can be specified as a timer or a counter, but TMB can only be used as a timer. In the timer mode, TMA and TMB are re-loaded up-counters. When timer overflows from \$0FFF to \$0000, the carry signal will make the timer automatically reload to the user's pre-set value and be up-counted again. At the same time, the carry signal will generate the INT signal if the corresponding bit is enabled in the INT ENABLE Register. If TMA is specified as a counter, users can reset by loading #0 into the counter. After the counter has been activated, the value of the counter can also be read from the counters at the same time. The read instruction will not affect the value of the counter or reset it.

Clock source of Timer/Counter can be selected as follows:

Timer/Counter		Clock Source
TMA	12-BIT TIMER	CPU CLOCK (T) or T/4
	12-BIT COUNTER	T/64, T/8192, T/65536 or EXT CLK
TMB	12-BIT TIMER	T or T/4
MODE SELECT REGISTER		TMA only, select timer or counter
TIMER CLOCK SELECTOR		Select T or T/4

6.9. Speech and Melody

Since the GPC21A3 provides a large ROM and wide range of CPU operation speeds, it is most suitable for speech and melody synthesis.

For speech synthesis, the GPC21A3 can provide NMI for accurate sampling frequency. Users can record or synthesize the sound and digitize it into the ROM. The sound data can be played back in the sequence of the control functions as designed by the user's program. Several algorithms are recommended for high fidelity and compression of sound including PCM, LOG PCM, and ADPCM.

For melody synthesis, the GPC21A3 provides the dual tone mode. After selecting the dual tone mode, users only need to fill either TMA or TMB, or both TMA and TMB to generate expected frequency for each channel. The hardware will toggle the tone wave automatically without entering into an interrupt service routine. Users are able to simulate musical instruments or sound effects by simply controlling the envelope of tone output.

7. ELECTRICAL SPECIFICATIONS

7.1. Absolute Maximum Ratings

Characteristics	Symbol	Ratings
DC Supply Voltage	V_+	< 7.0V
Input Voltage Range	V_{IN}	-0.5V to $V_+ + 0.5V$
Operating Temperature	T_A	0°C to +60°C
Storage Temperature	T_{STO}	-50°C to +150°C

Note: Stresses beyond those given in the Absolute Maximum Rating table may cause operational errors or damage to the device. For normal operational conditions see AC/DC Electrical Characteristics.

7.2. AC Characteristics ($T_A = 25^\circ\text{C}$)

Characteristics	Symbol	Limit			Unit	Test Condition
		Min.	Typ.	Max.		
OSC Frequency	F_{OSC2}	-	2.0	4.0	MHz	VDD = 2.4V - 3.6V, 2-battery
		-	4.0	6.0	MHz	VDD = 3.6V - 5.5V, 3-battery

7.3. DC Characteristics (VDD = 3.0V, $T_A = 25^\circ\text{C}$)

Characteristics	Symbol	Limit			Unit	Test Condition
		Min.	Typ.	Max.		
Operating Voltage	VDD	2.4	-	3.6	V	For 2-battery
Operating Current	I_{OP}	-	1.5	2.0	mA	$F_{CPU} = 3.0\text{MHz}$ @ 3.0V, no load
Standby Current	I_{STBY}	-	-	2.0	μA	VDD = 3.0V
Audio output current	I_{AUD}	-	-1.5	-	mA	VDD = 3.0V, one-channel
Input High Level	V_{IH}	2.0	-	-	V	VDD = 3.0V
Input Low Level	V_{IL}	-	-	0.8	V	VDD = 3.0V
Output High I (IOC, IOD)	I_{OH}	-1.0	-	-	mA	VDD = 3.0V, $V_{OH} = 2.0V$
Output Sink I (IOC, IOD)	I_{OL}	2.0	-	-	mA	VDD = 3V, $V_{OL} = 0.8V$
Input Resistor (IOD)	R_{IN}	-	110	-	Kohm	Pull Low, VDD = 3.0V

7.4. DC Characteristics (VDD = 5.0V, $T_A = 25^\circ\text{C}$)

Characteristics	Symbol	Limit			Unit	Test Condition
		Min.	Typ.	Max.		
Operating Voltage	VDD	3.6	-	5.5	V	For 3-battery
Operating Current	I_{OP}	-	4.0	5.0	mA	$F_{CPU} = 4.0\text{MHz}$ @ 5.0V, no load
Standby Current	I_{STBY}	-	-	2.0	μA	VDD = 5.0V
Audio output current	I_{AUD}	-	-3.0	-	mA	VDD = 5.0V, one-channel
Input High Level	V_{IH}	3.0	-	-	V	VDD = 5.0V
Input Low Level	V_{IL}	-	-	0.8	V	VDD = 5.0V
Output High I (IOC, IOD)	I_{OH}	-1.0	-	-	mA	VDD = 5.0V, $V_{OH} = 4.2V$
Output Sink I (IOC, IOD)	I_{OL}	4.0	-	-	mA	VDD = 5.0V, $V_{OL} = 0.8V$
Input Resistor (IOD)	R_{IN}	-	60	-	Kohm	Pull Low, VDD = 5.0V

7.5. The Relationship between the R_{OSC} and the F_{CPU}

7.5.1. $V_{DD} = 3.0V, T_A = 25^\circ C$

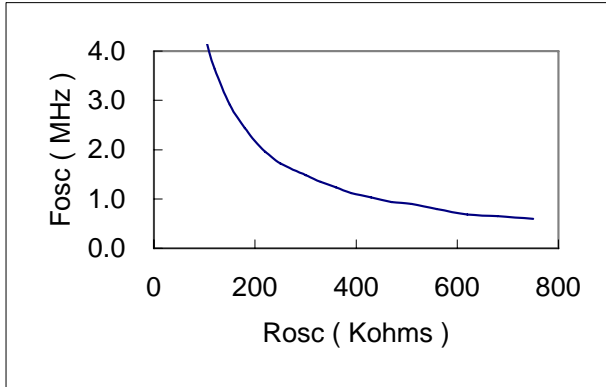

7.5.4. Frequency vs. VDD

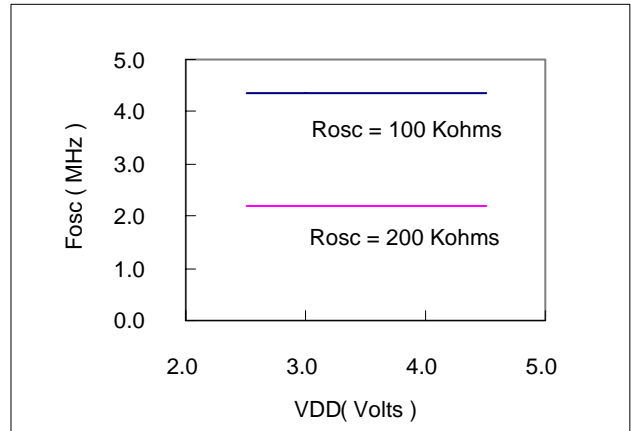

7.5.2. $V_{DD} = 4.5V, T_A = 25^\circ C$

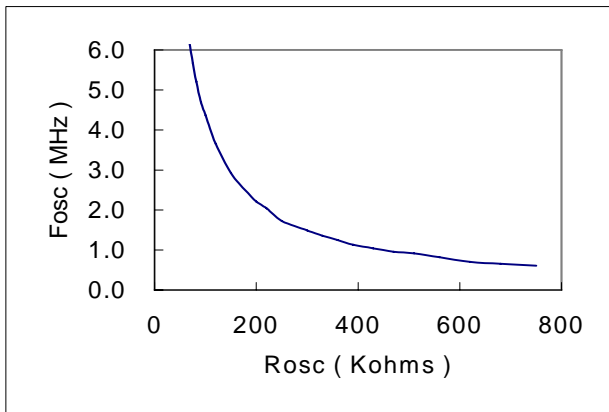

7.5.5. Operating current vs. frequency vs. VDD

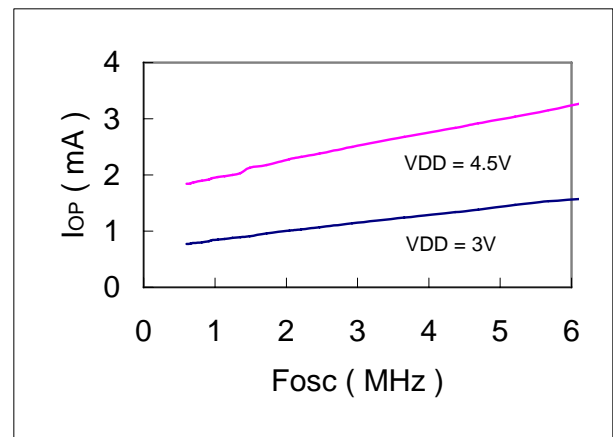

7.5.3. Frequency vs. temperature

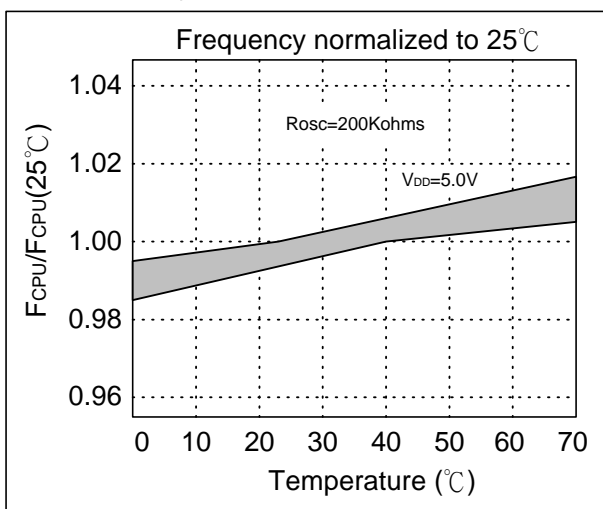

8. APPLICATION CIRCUITS

8.1. Application Circuit

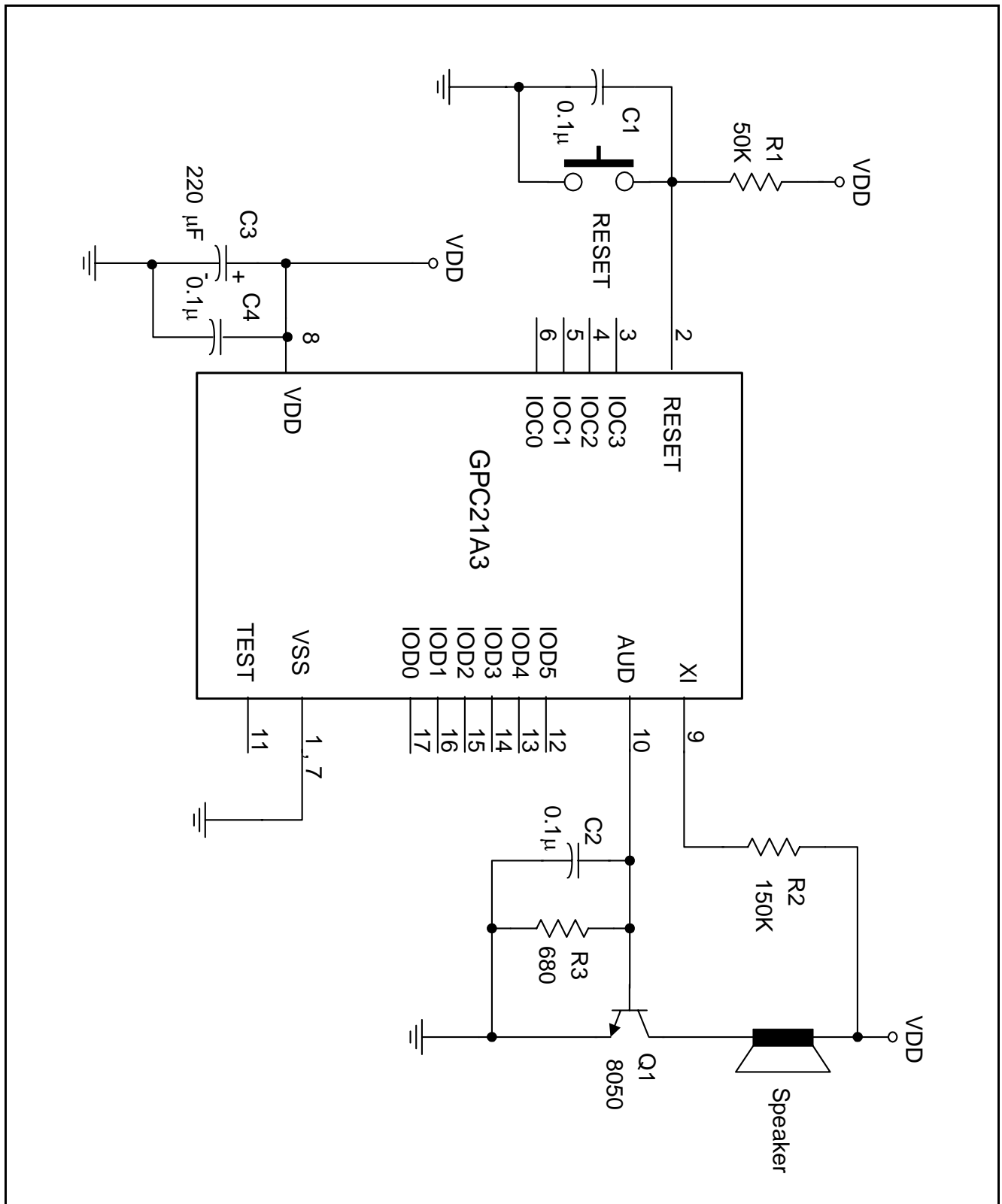

8.2. Current Mode DAC Speaker Driver

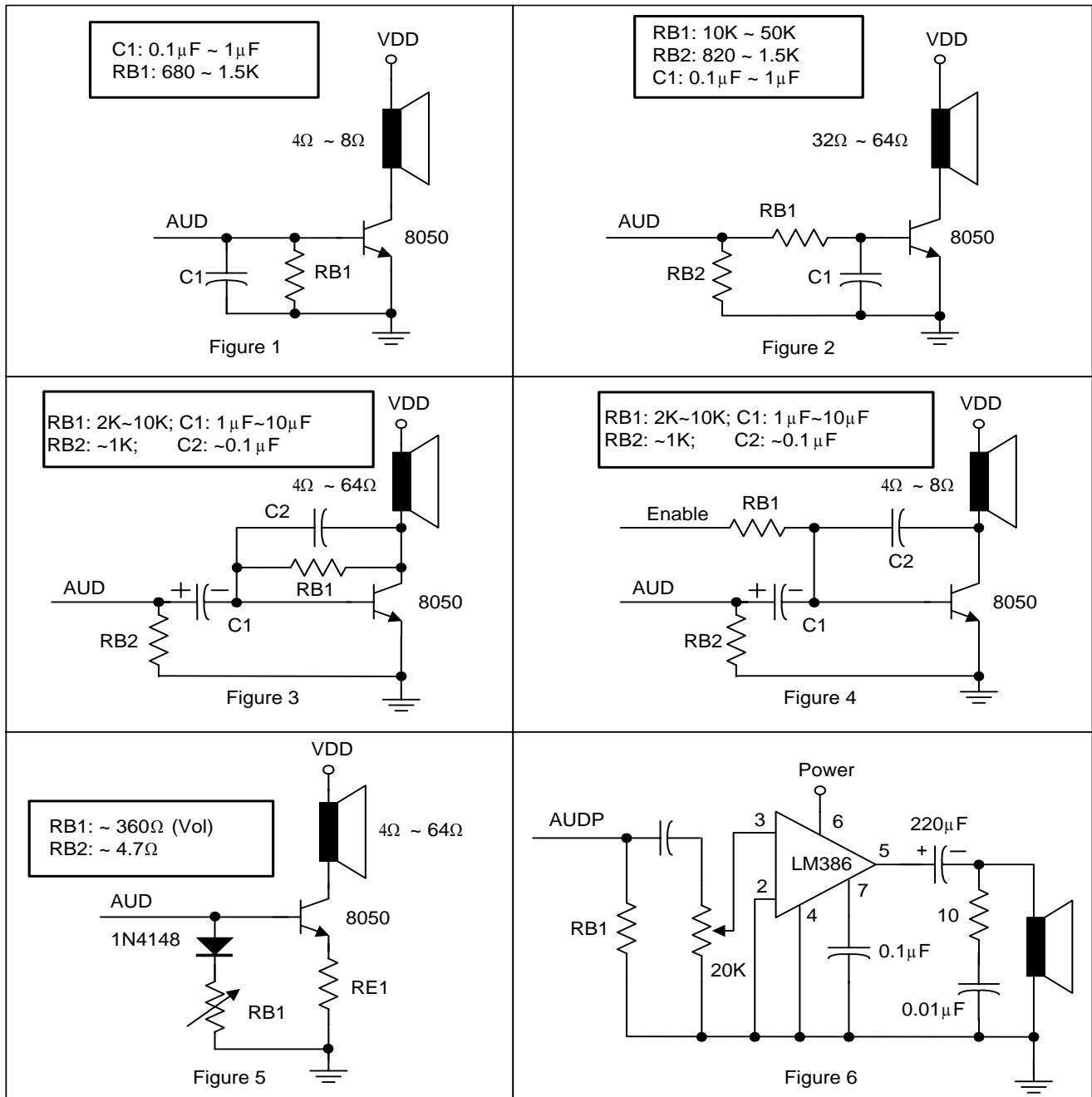

Figure 1: The simplest CKT uses with low impedance speaker. It has high operation current, but low cost.

Figure 2: It is the same as Figure 1 but a high impedance speaker is used.

Figure 3: The CKT contains a low pass filter. It is capable of providing higher speech quality, but it takes higher operation current.

Figure 4: Improved version of Figure 3. The standby current can be controlled by the enable pin.

Figure 5: The current mirror mode. It is able to control the volume. In addition, it is more stable and has lower operation current than Figure 1-3.

Figure 6: High quality, low operation current CKT, but more expensive.

9. PACKAGE/PAD LOCATIONS

9.1. PAD Assignment

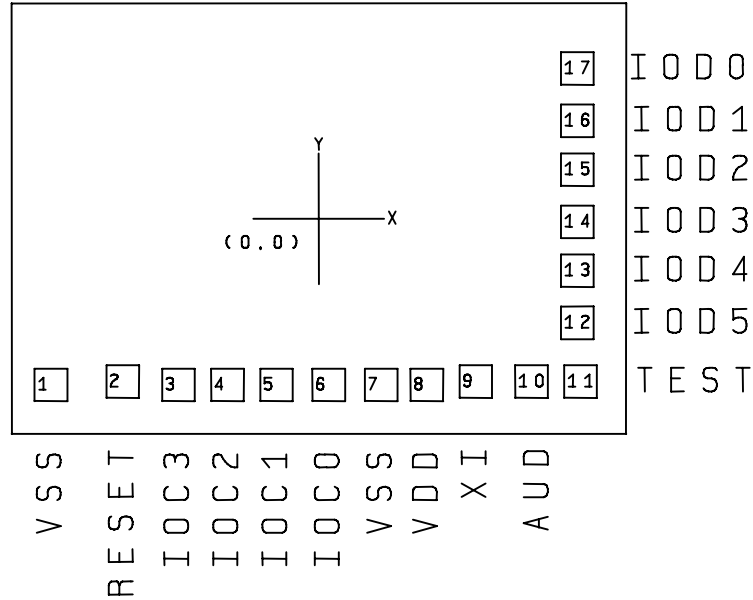

This IC substrate should be connected to VSS

Note1: To ensure that the IC functions properly, bond all VDD and VSS pins.

Note2: The 0.1μF capacitor between VDD and VSS should be placed to IC as close as possible.

9.2. Ordering Information

Product Number	Package Type
GPC21A3-NnnV-C	Chip form

Note1: Code number is assigned for customer.

Note2: Code number (N = A - Z or 0 - 9, nn = 00 - 99); version (V = A - Z).

10. DISCLAIMER

The information appearing in this publication is believed to be accurate.

Integrated circuits sold by Generalplus Technology are covered by the warranty and patent indemnification provisions stipulated in the terms of sale only. GENERALPLUS makes no warranty, express, statutory implied or by description regarding the information in this publication or regarding the freedom of the described chip(s) from patent infringement. FURTHERMORE, GENERALPLUS MAKES NO WARRANTY OF MERCHANTABILITY OR FITNESS FOR ANY PURPOSE. GENERALPLUS reserves the right to halt production or alter the specifications and prices at any time without notice. Accordingly, the reader is cautioned to verify that the data sheets and other information in this publication are current before placing orders. Products described herein are intended for use in normal commercial applications. Applications involving unusual environmental or reliability requirements, e.g. military equipment or medical life support equipment, are specifically not recommended without additional processing by GENERALPLUS for such applications. Please note that application circuits illustrated in this document are for reference purposes only.

11. REVISION HISTORY

Date	Revision #	Description	Page
DEC. 12, 2005	1.1	Modify "max. operating voltage" to section 3 and 7.	3, 8
OCT. 31, 2005	1.0	Original	14