



GPCE061A

16-Bit Sound Controller With 32K X 16 Flash Memory

OCT. 01, 2013

Version 1.5

Table of Contents

	<u>PAGE</u>
1. GENERAL DESCRIPTION	4
2. BLOCK DIAGRAM	4
3. FEATURES	4
4. APPLICATION FIELD	4
5. SIGNAL DESCRIPTIONS	5
5.1. PAD ASSIGNMENT	6
6. FUNCTIONAL DESCRIPTIONS	7
6.1. CPU	7
6.2. MEMORY	7
6.2.1. SRAM	7
6.2.2. Flash memory	7
6.3. PLL, CLOCK, POWER MODE	7
6.3.1. PLL (Phase Lock Loop)	7
6.4. STANDBY MODE	7
6.5. LOW VOLTAGE DETECTION AND LOW VOLTAGE RESET	8
6.5.1. Low voltage detection (LVD)	8
6.5.2. Low voltage reset	8
6.6. INTERRUPT	8
6.7. I/O	8
6.8. TIMER / COUNTER	9
6.8.1. Timebase	10
6.9. SLEEP, WAKEUP AND WATCHDOG	10
6.9.1. Wakeup and sleep	10
6.9.2. Watchdog	10
6.10. ADC (ANALOG TO DIGITAL CONVERTER) / DAC	10
6.11. SERIAL INTERFACE I/O (SIO)	11
6.12. UART	11
6.13. AUDIO ALGORITHM	11
6.14. IDE TOOLS FUNCTION	11
6.15. BONDING OPTION SUMMARY	12
6.15.1. Watchdog function	12
6.16. SECURITY FUNCTION	12
7. ELECTRICAL SPECIFICATIONS	13
7.1. ABSOLUTE MAXIMUM RATINGS	13
7.2. DC CHARACTERISTICS (VDD = 3.6V, VDD _{IO} = 3.6V (PORTA & B), T _A = 25°C)	13
7.3. DC CHARACTERISTICS (VDD = 3.3V, VDD _{IO} = 5.5V (PORTA & B), T _A = 25°C)	14
7.4. DC CHARACTERISTICS (VDD = 3.3V, VDD _{IO} = 3.3V (PORTA & B), T _A = 25°C)	14
7.5. ADC CHARACTERISTICS (VDD = 3.3V, T _A = 25°C)	15
7.6. V2VREF REGULATOR CHARACTERISTICS (VDD = 3.3V, T _A = 25°C)	15
7.7. DAC CHARACTERISTICS (VDD = 3.3V, T _A = 25°C)	15
7.8. PULL HIGH RESISTER AND VDD _{IO}	16
7.9. I/O OUTPUT HIGH CURRENT I _{OH} AND V _{OH}	16

7.10. PULL LOW RESISTER AND V_{DDIO}	16
7.11. I/O OUTPUT LOW CURRENT I_{OL} AND V_{OL}	16
7.12. DAC OUTPUT CURRENT VS. VDD (2MA MODE WITH 500HM RESISTOR)	16
7.13. DAC OUTPUT CURRENT VS. VDD (3MA MODE WITH 500HM RESISTOR)	16
8. APPLICATION CIRCUITS	17
8.1. APPLICATION CIRCUIT - (1)	17
8.2. APPLICATION CIRCUIT - (2)	18
8.3. APPLICATION CIRCUIT - (3)	19
8.4. APPLICATION CIRCUIT - (4)	20
8.5. APPLICATION CIRCUIT - (5)	21
8.6. APPLICATION CIRCUIT - (6)	22
8.7. APPLICATION CIRCUIT - (7)	23
9. PACKAGE/PAD LOCATIONS	24
9.1. ORDERING INFORMATION	24
9.2. PACKAGE INFORMATION	24
9.2.1. LQFP 80	24
10. TABLE OF GPCE061/060/040 COMPARISON	27
11. DISCLAIMER	28
12. REVISION HISTORY	29

16-BIT SOUND CONTROLLER WITH 32K X 16 FLASH MEMORY

1. GENERAL DESCRIPTION

The GPCE061A, a 16-bit architecture product, carries the newest 16-bit microprocessor, $\mu'nSP^{\text{TM}}$ (pronounced as *micro-n-SP*), developed by Sunplus Technology. This high processing speed assures the $\mu'nSP^{\text{TM}}$ is capable of handling complex digital signal processes easily and rapidly. Therefore, the GPCE061A is applicable to the areas of digital sound process and voice recognition. The operating voltage of 3.0V through 3.6V and speed of 0.32MHz through 49.152MHz yield the GPCE061A to be easily used in varieties of applications. The memory capacity includes 32K-word flash memory plus a 2K-word working SRAM. Other features include 32 programmable multi-functional I/Os, two 16-bit timers/counters, 32768Hz Real Time Clock, Low Voltage Reset/Detection, eight channels 10-bit ADC (one channel built-in MIC amplifier with auto gain controller), 10-bit DAC output and many others.

2. BLOCK DIAGRAM

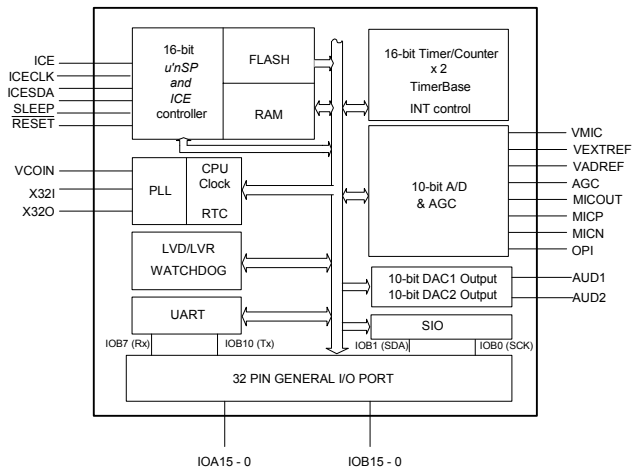

3. FEATURES

- 16-bit $\mu'nSP^{\text{TM}}$ microprocessor
- CPU clock: 0.32MHz - 49.152MHz
- Operating voltage: 3.0V - 3.6V
- Program Flash Operating voltage: 3.0V - 3.6V
- IO PortA & B operating voltage: 3.0V - 5.5V
- 32K-word flash memory
- 2K-word working SRAM
- Software-based audio processing
- Crystal Resonator
- Standby mode (Clock Stop mode) for power savings, Max. 2.0 μ A @ VDD = 3.6V
- Two 16-bit timers/counters
- Two 10-bit DAC outputs
- 32 general I/Os (bit programmable)
- 14 INT sources with two priority levels
- Key wakeup function (IOA0 - 7)
- PLL feature for system clock
- 32768Hz Real Time Clock (RTC)
- Eight channels 10-bit AD converter
- ADC external top reference voltage
- 2.0V voltage regulator output, 5mA of driving capability
- Serial interface I/O (SIO)
- Built-in microphone amplifier and AGC function
- UART receiver and transmitter (full duplex)
- Low voltage reset and low voltage detection
- Watchdog enable (bonding option)
- ICE function for development and down load into flash memory
- Security function to protect code to be read and written.

4. APPLICATION FIELD

- Voice recognition products
- Intelligent interactive talking toys
- Advanced educational toys
- Kids learning products
- Kids storybook
- General speech synthesizer
- Long duration audio products
- Recording / playback products

5. SIGNAL DESCRIPTIONS

Mnemonic	PIN No.	Type	Description
IOA [15:8]	46 - 39	I/O	IOA [15:8]: bi-directional I/O ports.
IOA [7:0]	34 - 27	I/O	IOA [7:0] can be software programmed to wakeup I/O pins. IOA [6:0] can be optioned as ADC Line-in input.
IOB [15:11]	50 - 54	I/O	IOB [15:11]: bi-directional I/O ports.
IOB 10	57	I/O	IOB10 can also be selected as UART Transmitter (Tx).
IOB 9	58	I/O	IOB9 can also be Multi-duty cycle output of TimerB (BPWMO).
IOB 8	59	I/O	IOB8 can also be Multi-duty cycle output of TimerA (APWMO).
IOB 7	60	I/O	IOB7 can also be selected as UART receiver (Rx).
IOB 6	61	I/O	IOB6 is a bi-directional I/O ports.
IOB 5	62	I/O	IOB5 can also be selected as feedback signal with EXT2.
IOB 4	63	I/O	IOB4 can also be selected as feedback signal with EXT1.
IOB 3	64	I/O	IOB3 can also be selected as an external interrupt input pin (EXT2)(Negative-edge Triggered).
IOB 2	65	I/O	IOB2 can also be selected as an external interrupt input pin (EXT1)(Negative-edge Triggered).
IOB 1	66	I/O	IOB1 can also be selected as a serial interface data (SDA).
IOB 0	67	I/O	IOB0 can also be selected as a serial interface clock (SCK).
DAC1	12	O	Audio DAC1 output.
DAC2	13	O	Audio DAC2 output.
X32I	2	I	Oscillator Crystal input.
X32O	1	O	Oscillator Crystal output.
VCOIN	70	I	RC filter connection for PLL.
AGC	16	I	AGC control pin.
MICN	19	I	Microphone differential input (negative).
MICP	21	I	Microphone differential input (positive).
V2VREF	14	O	2.0V output voltage, 5.0mA of driving capability (can be used as external ADC Line_IN top reference voltage).
MICOUT	18	O	Microphone 1 st amplifier output.
OPI	17	I	Microphone 2 nd amplifier input.
VEXTREF	23	I	ADC Line_IN top external reference voltage input pin.
VMIC	25	O	Microphone power supply.
VADREF	22	O	AD reference voltage (generated by internal AD converter).
VDD	5, 69	I	Positive supply for logic.
VSS	10, 26, 71	I	Ground reference for logic and I/O pins.
VDDIO	37, 38, 56	I	Positive supply for I/O pins.
VSSIO	35, 36, 48	I	Ground reference for I/O pins.
AVDD	24	I	Positive supply for analog circuit including ADC, DAC and 2.0V regulator.
AVSS	15	I	Ground reference for analog circuit including ADC, DAC and 2.0V regulator.
RESET	68	I	An active low reset to the chip.
SLEEP	49	O	Sleep mode (active high).
ICE	7	I	ICE enable (active high).
ICECLK	8	I	ICE serial interface clock.
ICESDA	9	I/O	ICE serial interface data.
TEST	3	I	Connected to high for test mode, normally connected to GND (test mode disabled) or unconnected.
ROMT	47	I	Flash memory test, normally unconnected.

Mnemonic	PIN No.	Type	Description
N/C	55	I	Not used.
N/C	4	I	Do NOT bonding and connect this pin. If user bonding this pin, IC will not work.
WDGOPT*	6	I	Bonded for watchdog disabled, unbonded for watchdog enabled.
PFUSE, PVIN	20, 11	I	Security fuse.

Note*: WDGOPT is the watchdog option pin, selected by bonding option. Remain WDGOPT unbonded to enable the watchdog. In contrast, bonding this pad will disable watchdog. The reason of placing WDGOPT adjacent to VDD is to facilitate connection between VDD and WDGOPT when disabling watchdog is necessary.

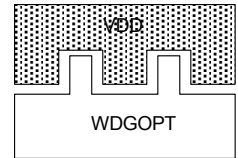

5.1. PAD Assignment

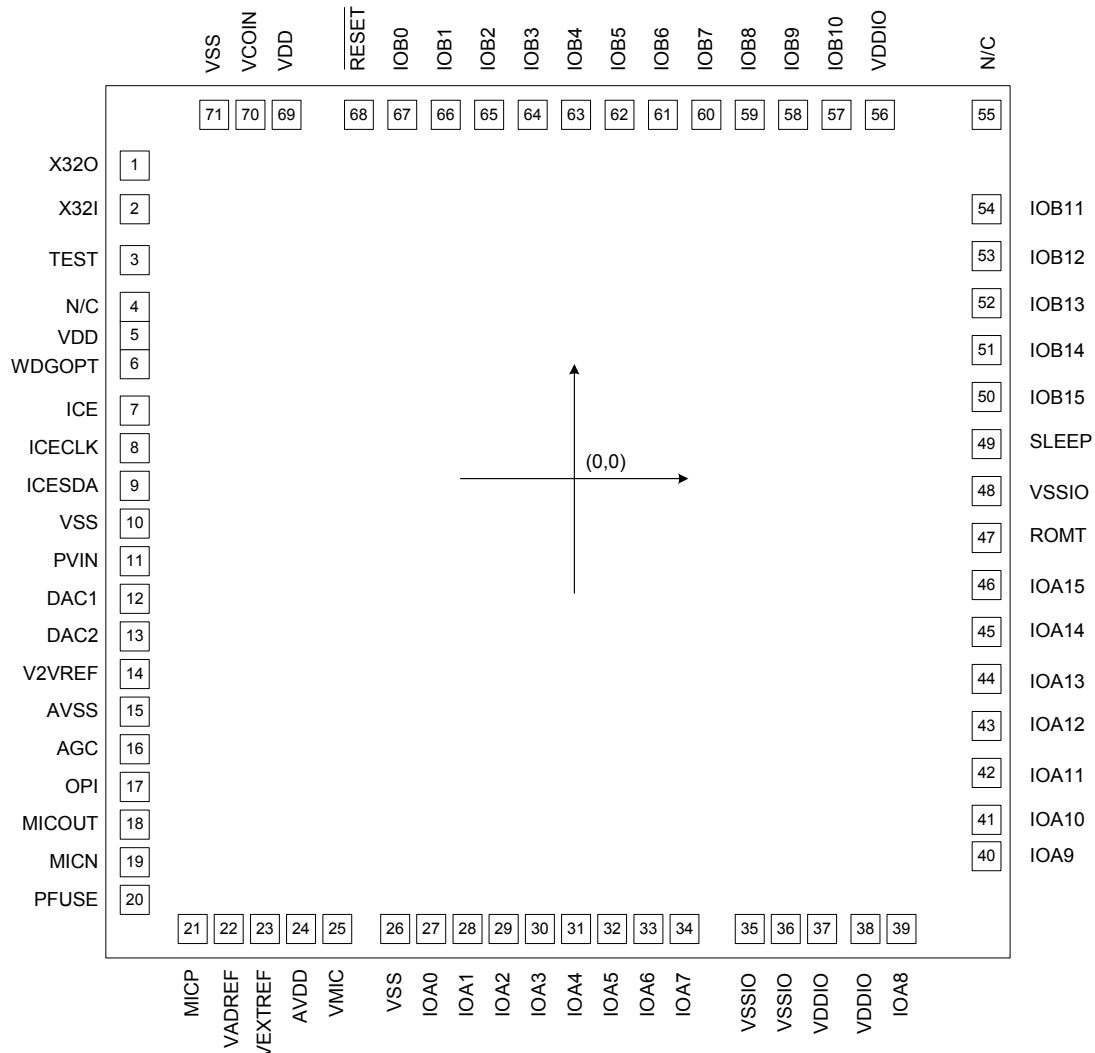

This IC substrate should be connected to VSS

- Note1:** To ensure the IC functions properly, please bond all of VDD and VSS pins.
- Note2:** The 0.1μF capacitor between VDD and VSS should be placed to IC as closed as possible.
- Note3:** Do NOT bonding and connect N/C pin. If user bonding N/C pin, IC will not work.

6.FUNCTIONAL DESCRIPTIONS

6.1. CPU

The GPCE061A is equipped with a 16-bit $\mu'nSP^{\text{TM}}$, the newest 16-bit microprocessor by Sunplus and pronounced as micro-n-SP. Eight registers are involved in $\mu'nSP^{\text{TM}}$: R1 - R4 (General-purpose registers), PC (Program Counter), SP (Stack Pointer), Base Pointer (BP) and SR (Segment Register). The interrupts include three FIQs (Fast Interrupt Request) and eight IRQs (Interrupt Request), plus one software-interrupt, BREAK.

Moreover, a high performance hardware multiplier with the capability of FIR filter is also built in to reduce the software multiplication loading.

6.2. Memory

6.2.1. SRAM

The amount of SRAM is 2K-word (including Stack), ranged from \$0000 through \$07FF with access speed of two CPU clock cycles.

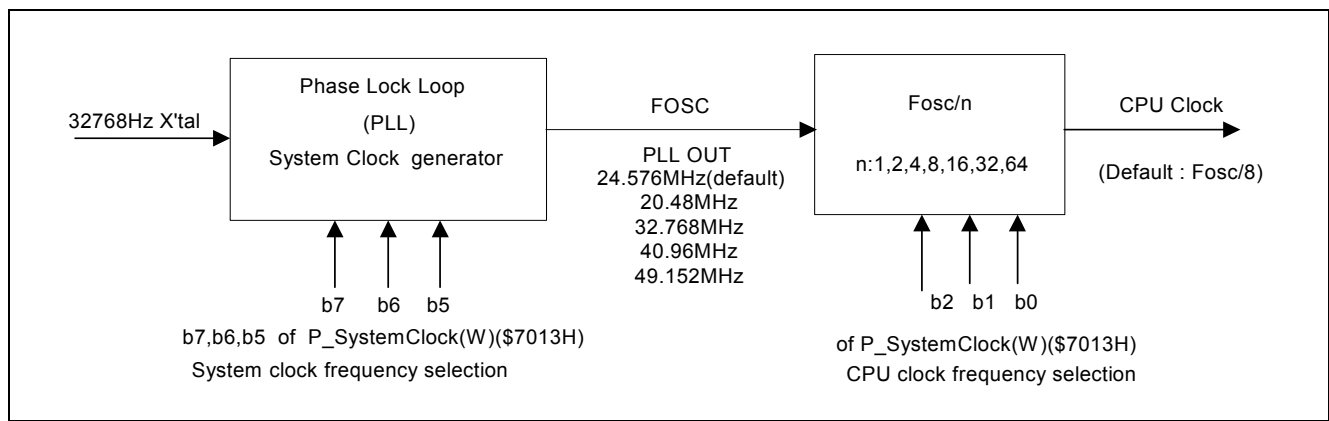

6.2.2. Flash memory

Flash memory (\$008000 ~ \$00FFFF) is a high-speed memory with access speed of two CPU clock cycles. FLASH erase and program functions must be used in IDE tools.

6.3. PLL, Clock, Power Mode

6.3.1. PLL (Phase Lock Loop)

The purpose of PLL is to provide a base frequency (32768Hz) and to pump the frequency from 20.48MHz to 49.152MHz for system clock (F_{osc}). The default PLL frequency is 24.576MHz.

6.3.1.1. System clock

Basically, the system clock is provided by PLL and programmed by the Port_SystemClock (W) to determine the frequency of clock for system. The default system clock $F_{osc} = 24.576\text{MHz}$ and CPU clock is $F_{osc}/8$ if not specified. The initial CPU clock is $F_{osc}/8$ after system wakes up and to be adjusted to desired CPU clock by programming the Port_SystemClock (W). This avoids Flash ROM reading failure when system wakes up.

6.3.1.2. 32768Hz RTC

The Real Time Clock (RTC) is normally used in watch, clock or other time related products. A 2Hz-RTC (1/2 second) function is loaded in GPCE061A. The RTC counts the timing as well as to

wake CPU up whenever RTC occurs. Since the RTC is generated each 0.5 seconds, time can be traced by the numbers of RTC occurrence. In addition, GPCE061A supports 32768Hz oscillator in normal mode and auto-power-saving mode. In normal mode, 32768Hz OSC always runs at the highest power consumption. In auto-power-saving mode, however, it runs in normal mode for the first 7.5 seconds and changes back to power-saving mode automatically to save powers.

6.4. Standby Mode

The GPCE061A also offers a standby mode for low power application needs. To enter standby mode, the desired key wakeup port (IOA [7:0]) must be configured to input first. And read the Port_IOA_Latch(R) to latch the IOA state before entering the standby mode. Also remember to enable the corresponding interrupt source(s) for wakeup. After that, stop the CPU clock by writing the STOP CLOCK Register (b0~b2 of Port_SystemClock (W)) to enter standby mode. In such mode, SRAM and I/Os remain in the previous states till CPU being awoken. The wakeup sources in GPCE061A include Port IOA7 - 0 and IRQ1 - IRQ6. After GPCE061A is awoken, the CPU will continue to execute the program. Programmer can also enable or disable the 32768Hz OSC when CPU is in standby mode.

6.5. Low Voltage Detection and Low Voltage Reset

6.5.1. Low voltage detection (LVD)

There are two LVD levels to be selected: 2.9V, and 3.3V. These levels can be programmed via Port_LVD_Ctrl (W). As an example, suppose LVD is given to 2.9V. When the voltage drops below 2.9V, the b15 of Port_LVD_Ctrl is read as HIGH. In such state, program can be designed to react to this condition.

6.5.2. Low voltage reset

In addition to the LVD, the GPCE061A has another important function, Low Voltage Reset (LVR). With the LVR function, a reset signal is generated to reset system when the operating voltage drops below 2.3V for 10 consecutive CPU clock cycles. Without LVR, the CPU becomes unstable and malfunctions when the operating voltage drops below 2.3V. The LVR will reset all functions to the initial operational (stable) states when the voltage drops below 2.3V. A LVR timing diagram is given as follows:

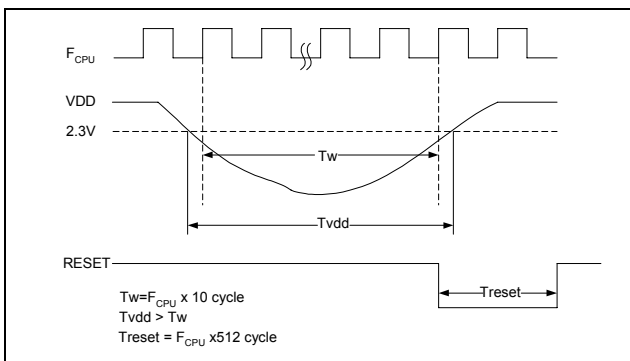

6.6. Interrupt

The GPCE061A has 14 interrupt sources, grouped into two types, FIQ (Fast Interrupt Request) and IRQ (Interrupt request). The priority of FIQ is higher than IRQ. FIQ is the high-priority interrupt while IRQ is the low-priority one. An IRQ can be interrupted by a FIQ, but not by another IRQ. A FIQ cannot be interrupted by any other interrupt sources.

Interrupt Source	Interrupt Name	Priority
PWM Service (Fosc/1024)	FIQ_PWM/IRQ0_PWM	High(FIQ)
Timer A	FIQ_TMA/IRQ1_TMA	High(FIQ)
Timer B	FIQ_TMB/IRQ2_TMB	High(FIQ)
EXT2	IRQ3_EXT2	Low
EXT1	IRQ3_EXT1	Low

Interrupt Source	Interrupt Name	Priority
Key change wakeup	IRQ3_KEY	Low
4096Hz	IRQ4_4KHz	Low
2048Hz	IRQ4_2KHz	Low
1024Hz	IRQ4_1KHz	Low
4Hz	IRQ5_4Hz	Low
2Hz	IRQ5_2Hz	Low
Time-base 1	IRQ6_TMB1	Low
Time-base 2	IRQ6_TMB2	Low
UART (TxRDY or RxRDY)	UART IRQ	Low

6.7. I/O

Two I/O ports are built in GPCE061A, PortA and PortB. The PortA is an ordinary I/O with programmable wakeup capability. In addition to the regular IO function, the PortB can also perform some special functions in certain pins. Suppose operating voltage is running at 3.6V (VDD) and VDDIO (power for I/O) operates from 3.6V (VDD) to 5.5V. In such condition, the I/O pad is capable of operating from 0V through VDDIO. However IOB13 and IOB14 are recommended to operate $\leq 3.6V$ during standby mode, otherwise these two IOs will have current leakage. The following diagram is an I/O schematic.

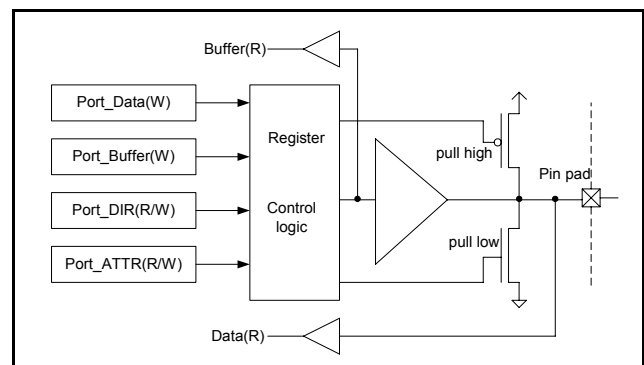

Although data can be written into the same register through Port_Data and Port_Buffer, they can be read from different places, Buffer (R) and Data (R). The IOA [7:0] is the key wakeup port. To activate key wakeup function, latch data on PORT_IOA_Latch and enable the key wakeup function. Wakeup is triggered when the PortA state is different from at the time latched. In addition to an ordinary I/O port, PortB carries some special functions. A summary of PortB special functions is listed as follows:

Special function in PortB

PortB	Special Function	Function Description	Note
IOB0	SCK	Serial interface clock	Refer to see SIO section
IOB1	SDA	Serial interface data	Refer to see SIO section
IOB2	EXT1	External interrupt source 1(Negative-edge Triggered)	IOB2 set as input mode
	Feedback Output1	Works with IOB4 by adding a RC circuit between them to get an OSC to EXT1 interrupt	IOB2 set as inverted output
IOB3	EXT2	External interrupt source 2(Negative-edge Triggered)	IOB3 set as input mode
	Feedback Output2	Works with IOB5 by adding a RC circuit between them to get an OSC to EXT2 interrupt	IOB3 set as inverted output
IOB4	Feedback Input1	-	-
IOB5	Feedback Input2	-	-
IOB7	Rx	UART Receiver	Refer to see UART section
IOB8	APWMO	TimerA PWM output	Refer to Timer/Counter section
IOB9	BPWMO	TimerB PWM output	Refer to Timer/Counter section
IOB10	Tx	UART Transmitter	Refer to UART section

Default state: Pull Low

PWM: Pulse Width Modulation

Refer to the above table, the configuration of IOB2, IOB3, IOB4, and IOB5 involves feedback function in which an OSC frequency can be obtained from EXT1 (EXT2) by simply adding a RC circuit between IOB2 (IOB3) and IOB4 (IOB5).

6.8. Timer / Counter

The GPCE061A provides two 16-bit timers/counters, TimerA and TimerB. The TimerA is called a universal counter. TimerB is a general-purpose counter. The clock source of TimerA comes from the combination of clock source A and clock source B. In TimerB, the clock source is given from source C. When timer overflows, an INT signal is sent to CPU to generate a time-out signal.

Clock of Source A	Clock of Source B	Clock of Source C
Fosc/2	2048Hz	Fosc/2
Fosc/256	1024Hz	Fosc/256
32768Hz	256Hz	32768Hz
8192Hz	TMB1	8192Hz
4096Hz	4Hz	4096Hz
1	2Hz	1
0	1	0
EXT1	EXT2	EXT1

Initially, write a value of N into a timer and select a desired clock source, timer will start counting from N, N+1, N+2, ... through FFFF. An INT (TimerA/TimerB) signal is generated at the next clock after reaching "FFFF" and the INT signal is transmitted to INT controller for further processing. At the same time, N will be reloaded into timer and start all over again. The clock source A is a high frequency source and clock source B is a low frequency source. The combination of clock source A and B provides a variety of speeds to TimerA. A "1" represents pass signal and not gating. In contrast, "0" indicates deactivating timer. The EXT1 and EXT2 are the external clock sources. Moreover, counter can generate time-out signal for input clock source to a four bits (16 levels) PWM pulse width counter. A variety of clock duration can be generated and exported from IOB8 (APWMO) and IOB9 (BPWMO).

The following example is a 3/16-duration cycle. The APWMO waveform is made by selecting a pulse width through Port_TimerA_Ctrl (W) [9:6]. As a result, each 16 cycles will generate a pulse width defined in control port. These PWM signals can be applied for controlling the speed of motor or other devices.

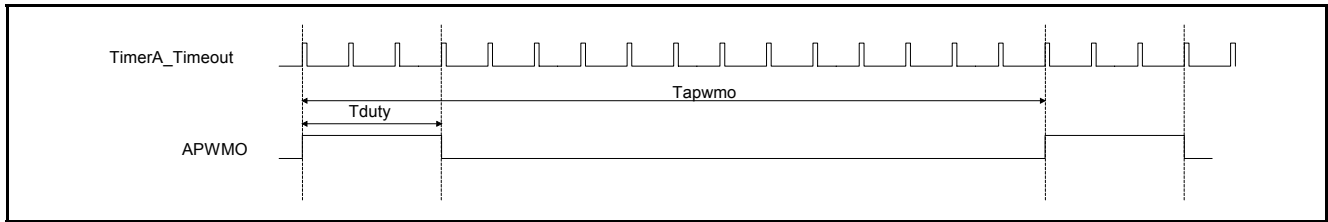

Generally speaking, the clock source A and C are fast clock sources and source B comes from RTC system (32768Hz). Therefore, clock source B can be utilized as a precise counter for time counting, e.g., the 2Hz clock can be used for real time counting.

6.8.1. Timebase

Timebase, generated by 32768Hz, is a combination of frequency selections. The outputs of timebase block are named to TMB1 and TMB2. TMB1 is frequency for TimerA (Clock source B). The TMB1 and TMB2 are the sources for Interrupt (IRQ6). Furthermore, timebases generates additional 2Hz to 4096Hz interrupt sources (IRQ4 and IRQ5) for Real-Time-Clock (RTC).

TMB2	TMB1
128Hz	8Hz
256Hz	16Hz
512Hz	32Hz
1024Hz	64Hz
Default: 128Hz	Default: 8Hz

6.9. Sleep, Wakeup and Watchdog

6.9.1. Wakeup and sleep

- 1) Sleep: After power-on reset, IC starts running until a sleep command occurs. When a sleep command is accepted, IC will turn the system clock (PLL) off. After all, it enters sleep mode.
- 2) Wakeup: CPU waking up from sleep mode requires a wakeup signal to turn the system clock (PLL) on. The IRQ signal makes CPU to complete the wakeup process and initialization. The key wakeup and interrupt sources (IRQ1 - IRQ6) can be used for wakeup sources.

6.9.2. Watchdog

The purpose of watchdog is to monitor if the system operates normally. Within a certain period, watchdog must be cleared. If watchdog is not cleared, CPU assumes the program has been running in an abnormal condition. As a result, the CPU will reset the system to the initial state and start running the program all over again. The watchdog function can be removed by bonding option. In GPCE061A, the clear period is 0.75 seconds. If watchdog is cleared within each 0.75 seconds, the system will not be reset. To clear watchdog, simply write "xxxx xxxx xxxx xx01B" to Port_Watchdog_Clear(W). The content written to Port_Watchdog_Clear(W) for watchdog clearance must be exactly the same as the one illustrated above (xxxx xxxx xxxx xx01B). Other values given to the Port_Watchdog_Clear(W) for watchdog clearance may end up with system reset. The watchdog function remains enabled during standby mode if the 32768Hz is turned on.

6.10. ADC (Analog to Digital Converter) / DAC

The GPCE061A has eight channels 10-bit ADC (Analog to Digital Converter). The function of an ADC is to convert analog signal to digital signal, e.g. a voltage level into a digital word. The eight channels of ADC can be seven channels of line-in from IOA [6:0] or one channel microphone (MIC) input through amplifier and AGC controller. The MIC amplifier circuit is capable of reducing common mode noise by transmitting signals through differential MIC Inputs (MICN, MICP). Moreover, an external resistor can be applied to adjust microphone gain and time of AGC operating. The AD needs to select source of line-in before conversion. The ADC is able to choose the external or internal (=AVDD) top reference voltage. If constant voltage source is unavailable, GPCE061A offers a constant voltage 2.0V with 5.0mA driving ability with a capacitor connected.

The GPCE061A has two 10-bit D/A with 2.0mA or 3.0mA driving current for audio outputs, DAC1 and DAC2.

6.11. Serial Interface I/O (SIO)

Serial interface I/O offers a one-bit serial interface for receiving data via two I/O pins, IOB0 (SCK) and IOB1 (SDA). This serial interface is capable of transmitting or

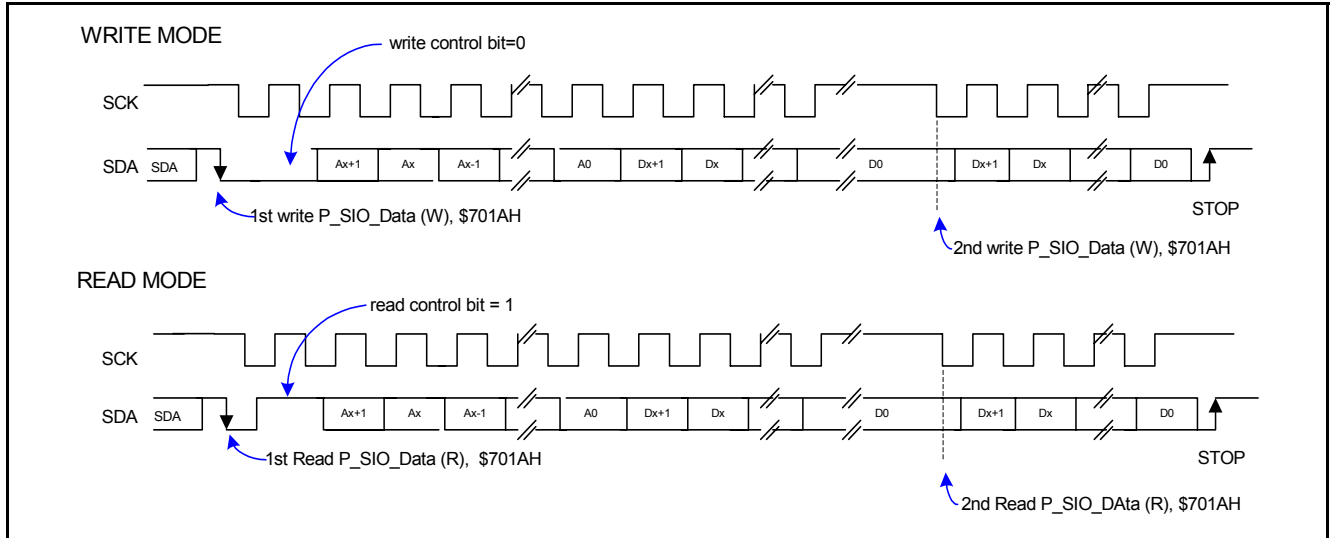

6.12. UART

UART block provides a full-duplex standard interface that facilitates the communication with other devices. With this interface, GPCE can transmit and receive simultaneously. The maximum baud-rate can be up to 115200bps. This function can be accomplished by using PortB and Interrupt (UART IRQ). The

Rx and Tx of UART are shared with IOB7 and IOB10. When GPCE061A receives and/or transmits a frame of data, the b7 (RxRDY) and/or b6 (TxRDY) in Port_UART_Command2(R) will be set to "1" and the UART IRQ is activated at the same time.

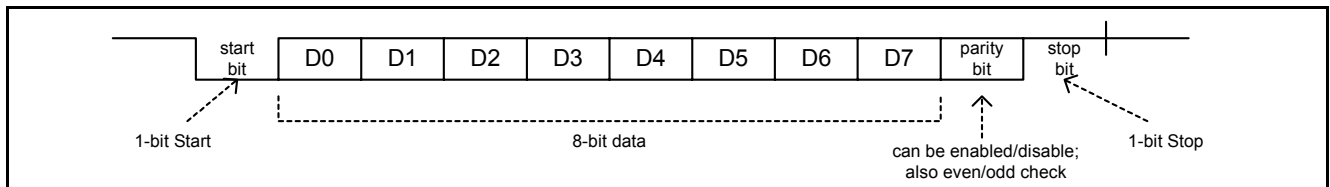

6.13. Audio Algorithm

The following speech types can be used in GPCE061A: PCM, SACM_S200, SACM_S480, SACM_S530, SACM_S720, SACM_A1600, SACM_A1601, SACM_A3600, SACM_DVR520, SACM_DVR1600, SACM_DVR3200, and SACM_DVR4800. For melody synthesis, the GPCE061A supports SACM_MS01 (FM) and SACM_MS02 (wave-table) synthesizers.

6.14. IDE Tools Function

The functions of IDE include the follows:

- 1). C compiler, Assembly, and Linker.
- 2). Download program into FLASH (refer to 8.7.application circuit-(7)).
- 3). Single step trace
- 4). Break point (break point for debugging)
- 5). Run (execute)

6.15. Bonding Option Summary

The GPCE061A has the following bonding option:

6.15.1. Watchdog function

WDGOPT is the optional pin for watchdog by bonding option. The shape looks as the figure given below. When watchdog is selected, WDGOPT is unbonded. If watchdog is not selected, WDGOPT is bonded. The reason for WDGOPT adjacent to VDD is that when watchdog is not selected, it is easy to make the connection between VDD and WDGOPT.

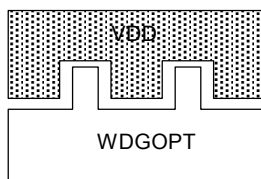

6.16. Security Function

Security function is able to protect code to be read or written. When program is downloaded into flash memory, program can be read/written from IDE tools. For security purpose, burn fuse to disable IDE function, where PFUSE supplies 7.0V and PVIN connects to ground (0V) about one second (Please refer to the following circuit diagram). After all, the flash memory can no longer be read or written.

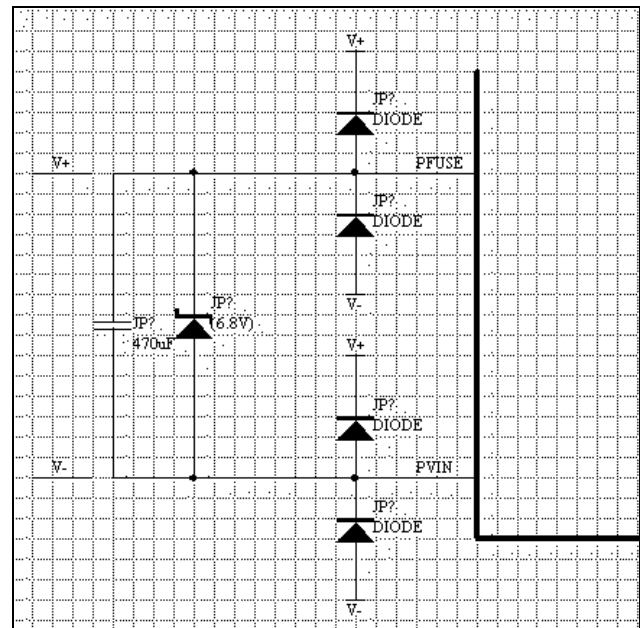

7. ELECTRICAL SPECIFICATIONS

7.1. Absolute Maximum Ratings

Characteristics	Symbol	Ratings
DC Supply Voltage	V_+	< 4.0V
PortA/B Pad Supply Voltage	VDD_{IO}	< 7.0V
Input Voltage Range	V_{IN}	-0.5V to V_+ + 0.5V
Operating Temperature	T_A	0°C to +60°C
Storage Temperature	T_{STO}	-50°C to +150°C

Note: Stresses beyond those given in the Absolute Maximum Rating table may cause operational errors or damage to the device. For normal operational conditions see DC Electrical Characteristics.

7.2. DC Characteristics (VDD = 3.6V, VDD_{IO} = 3.6V (PortA & B), T_A = 25°C)

Characteristics	Symbol	Limit			Unit	Test Condition
		Min.	Typ.	Max.		
Operating Voltage	VDD	3.0	3.3	3.6	V	-
Operating Current	I _{OP}	-	-	33	mA	F _{OSC} = 49.152MHz, AD, DAC disable, no load
Standby Current	I _{STB}	-	-	2.0	μA	Disable 32KHz crystal
				5.0		Enable 32KHz, Disable PLL (F _{OSC})
Input High Level	V _{IH}	0.7VDD _{IO}	-	-	V	-
Input Low Level	V _{IL}	-	-	0.3VDD _{IO}	V	-
Output DAC current (AUD1, AUD2)	I _{AUD}	-	-	-2.0	mA	2.0mA mode
				-3.0		3.0mA mode
Output High Current	I _{OH}	-	-	-3.2	mA	V _{OH} = 2.9V
Output Low Current	I _{OL}	-	-	7.0	mA	V _{OL} = 0.7V
Input Pull-Low Resister (PA15 :0, PB15 :0)	R _{PL}	-	-	165	KΩ	V _{IN} = VDD _{IO}
Input Pull-High Resister (PA15 :0, PB15 :0)	R _{PH}	-	-	210	KΩ	V _{IN} = VSS

7.3. DC Characteristics (VDD = 3.3V, VDDIO = 5.5V (PortA & B), TA = 25°C)

Characteristics	Symbol	Limit			Unit	Test Condition	
		Min.	Typ.	Max.			
Operating Voltage	VDD	3.0	3.3	3.6	V	-	
Operating Current	I _{OP}	-	26	-	mA	F _{OSC} = 49.152MHz, AD, DAC disable, no loading	
Standby Current	I _{STB}	-	-	2.0	μA	Disable 32KHz crystal When IOB13, IOB14 <= 3.6V	
				5.0		Enable 32KHz, Disable PLL (F _{OSC}) When IOB13, IOB14 <= 3.6V	
Input High Level	V _{IH}	0.7VDD _{IO}	-	-	V	-	
Input Low Level	V _{IL}	-	-	0.3VDD _{IO}	V	-	
Output DAC current (AUD1, AUD2)	I _{AUD}	-	-2.0	-	mA	2.0mA mode	For one channel DAC
			-3.0			3.0mA mode	
Output High Current	I _{OH}	-	-5.0	-	mA	V _{OH} = 4.0V	
Output Low Current	I _{OL}	-	12	-	mA	V _{OL} = 1.0V	
Input Pull-Low Resister (PA15:0, PB15:0)	R _{PL}	-	110	-	KΩ	V _{IN} = VDD _{IO}	
Input Pull-High Resister (PA15:0, PB15:0)	R _{PH}	-	150	-	KΩ	V _{IN} = VSS	

7.4. DC Characteristics (VDD = 3.3V, VDDIO = 3.3V (PortA & B), TA = 25°C)

Characteristics	Symbol	Limit			Unit	Test Condition	
		Min.	Typ.	Max.			
Operating Voltage	VDD	3.0	3.3	3.6	V	-	
Operating Current	I _{OP}	-	26	-	mA	F _{OSC} = 49.152MHz, AD, DAC disable, no loading	
Standby Current	I _{STB}	-	-	2.0	μA	Disable 32KHz crystal	
				5.0		Enable 32KHz, Disable PLL (F _{OSC})	
Input High Level	V _{IH}	0.7VDD _{IO}	-	-	V	-	
Input Low Level	V _{IL}	-	-	0.3VDD _{IO}	V	-	
Output DAC current (AUD1, AUD2)	I _{AUD}	-	-2.0	-	mA	2.0mA mode	For one channel DAC
			-3.0			3.0mA mode	
Output High Current	I _{OH}	-	-2.9	-	mA	V _{OH} = 2.6V	
Output Low Current	I _{OL}	-	6.7	-	mA	V _{OL} = 0.7V	
Input Pull-Low Resister (PA15:0, PB15:0)	R _{PL}	-	175	-	KΩ	V _{IN} = VDD _{IO}	
Input Pull-High Resister (PA15:0, PB15:0)	R _{PH}	-	242	-	KΩ	V _{IN} = VSS	

7.5. ADC Characteristics (VDD = 3.3V, T_A = 25°C)

Characteristics	Symbol	Unit			Unit
		Min.	Typ.	Max.	
ADC Power Dissipation for LINE_IN	I _{ADC}	-	1.0	-	mA
ADC Power Dissipation For MIC_IN	-	-	1.9	-	mA
ADC LINE_IN Input Voltage Range from IOA[6:0]	VINL (Note 1)	VSS - 0.3	-	VDD + 0.3	V
ADC Microphone Input Voltage Range	VINM	VSS - 0.3	-	VDD + 0.3	V
External ADC Top Voltage	VEXTREF (Note 2)	2.0	-	VDD + 0.3	V
Resolution of ADC	RESO	-	-	10	bits
Signal-to-Noise Plus Distortion of ADC from Line In	SINAD (Note 4)	-	56	-	dB
Effective Number of Bit	ENOB (Note 5)	-	9.0	-	bits
Integral Non-Linearity of ADC	INL	-	±4.0	-	LSB (Note 3)
Differential Non-Linearity of ADC	DNL (Note 6)	-	±0.5	-	LSB
AD Conversion Rate	F _{CONV}	-	-	F _{CPU} /512	Hz
Microphone Amplifier Gain (Note 7)	A _{MIC}	-	-	42	dB

Note1: Internal protection diodes clamp the analog input to VDD and VSS. These diodes allow the analog input to swing from (VSS-0.3V) to (VDD+0.3V) without causing damages to the devices.

Note2: The ADC performance is limited by the system noise level and therefore, the GPCE061A only guarantees to the 8-bit accuracy when VEXTREF is 2.0V.

Note3: The LSB means Least Significant Bit. VINL = 2.0V, 1LSB = 2.0V/2¹⁰ = 1.953mV.

Note4: The SINAD testing condition at VINLp-p = 0.8*VDD, F_{CONV} = F_{cpu}/512 = 49MHz/512 = 95KHz, Fin = 1.0KHz Sine waves at VDD = 3.0V from the IOA [6:0] input.

Note5: ENOB = (SINAD-1.76)/6.02.

Note6: The ADC of GPCE061A guarantees no data missed during conversion.

Note7: The microphone amplifier maximum gain = 15 * (60K / (1.5K + REXT)) V/V. The REXT is external resistor between OPI and MICOUT. The gain is 132V/V (=42dB) when REXT is 5.1K.

7.6. V2VREF Regulator Characteristics (VDD = 3.3V, T_A = 25°C)

Characteristics	Symbol	Limit			Unit	Test Condition
		Min.	Typ.	Max.		
Output Voltage Accuracy	V2VREF	1.8	2.0	2.2	V	AVDD = 3.3V, I _{OUT} ≤ 5mA
Output Current	I _{OUT}	-	5.0	-	mA	AVDD = 3.3V, V2VREF = 2.0V
Input Voltage	AVDD	3.0	3.3	3.6	V	I _{OUT} ≤ 5mA, V2VREF = 2.0V

Note1: The V2VREF Regulator output current maximum ≤ 5mA, It is not matching to make a large current driver application. Our suggestion can be used as external ADC Line_IN reference voltage.

7.7. DAC Characteristics (VDD = 3.3V, T_A = 25°C)

Characteristics	Symbol	Unit			Unit
		Min.	Typ.	Max.	
DAC resolution	RESO	-	-	10	bit
Signal to Noise Ratio of DAC	SNR	-	54	-	dB
Sample Rate	F _s	-	-	100K	Hz
Output Voltage Accuracy range	VDAC	0	-	VDD/2	V

Note1: The DAC output voltage in accuracy range have max 10 bits resolution.

7.8. Pull High Resistor and VDD_{IO}

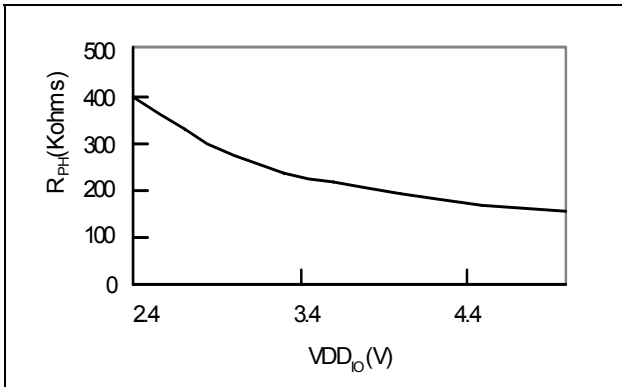

7.11. I/O Output Low Current I_{OL} and V_{OL}

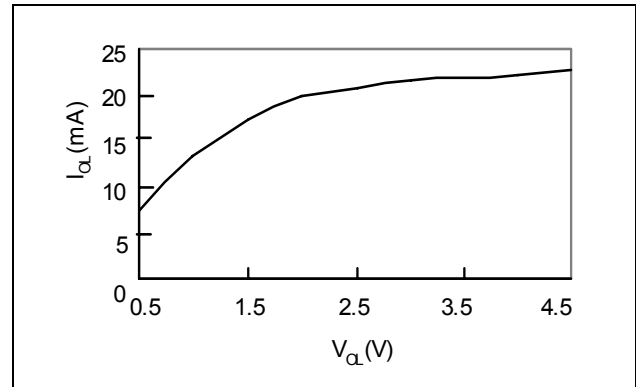

7.9. I/O Output High Current I_{OH} and V_{OH}

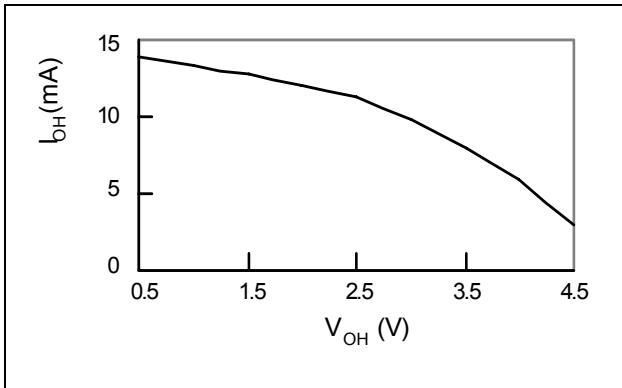

7.12. DAC output current vs. VDD (2mA mode with 500hm resistor)

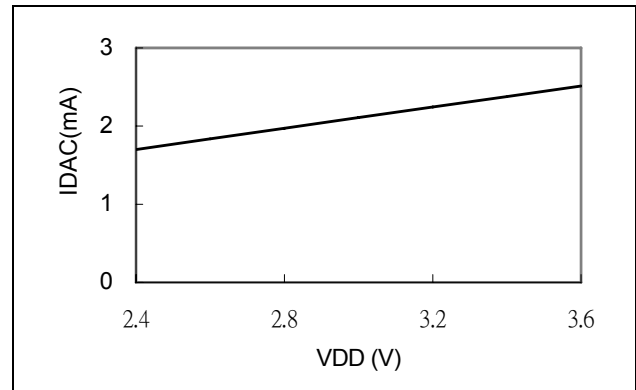

7.10. Pull Low Resistor and VDD_{IO}

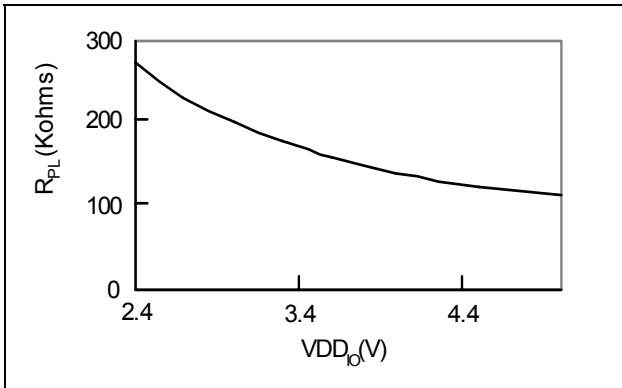

7.13. DAC output current vs. VDD (3mA mode with 500hm resistor)

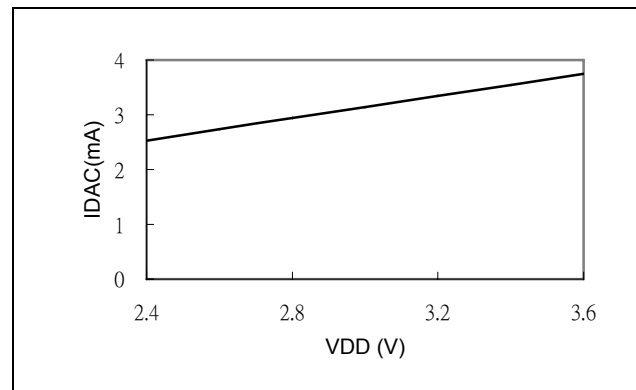

8.APPLICATION CIRCUITS

8.1. Application Circuit - (1)

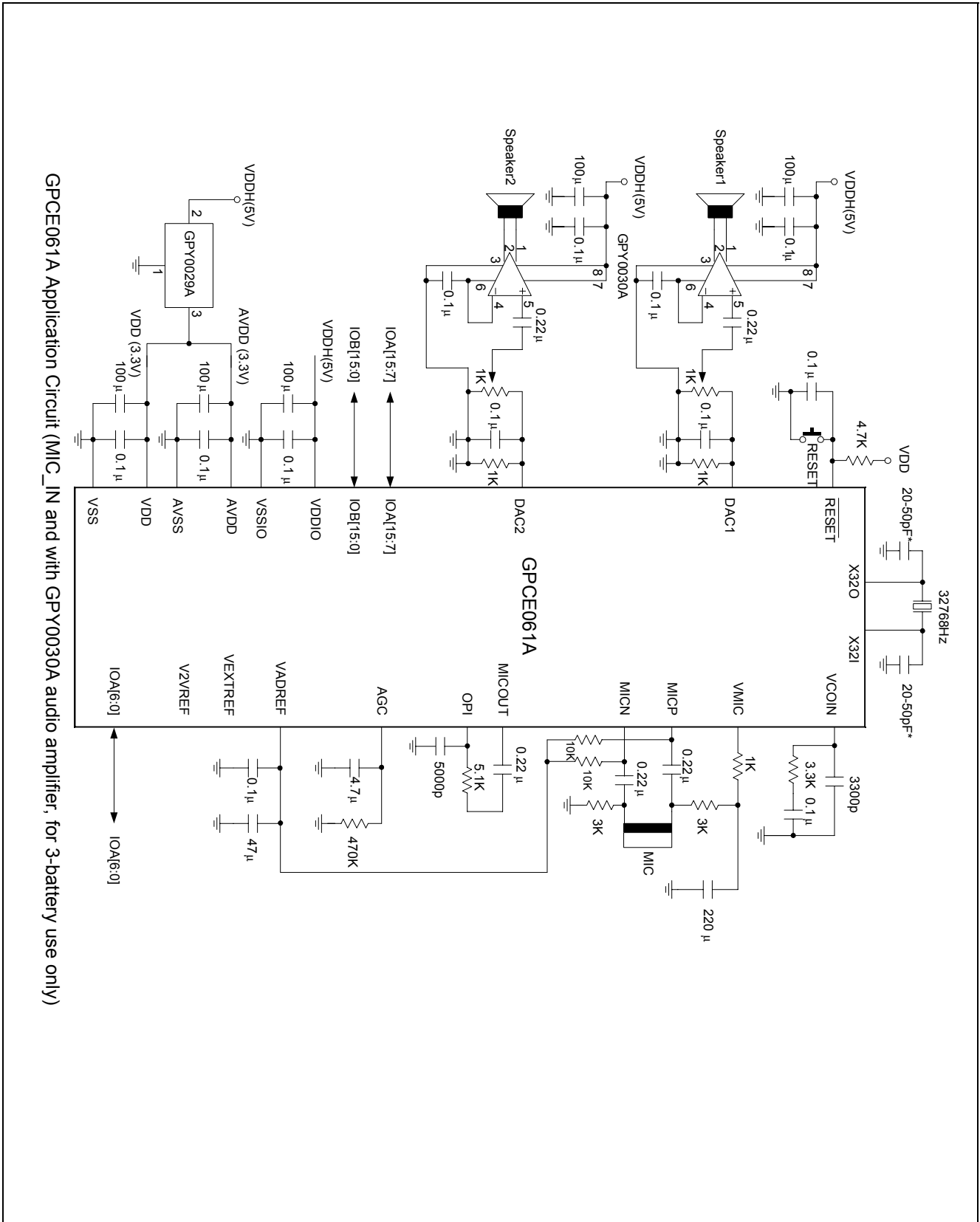

GPCE061A Application Circuit (MIC_IN and with GPY0030A audio amplifier, for 3-battery use only)

Note*: These capacitor values are for design guidance only. Different capacitor values may be required for different crystal/resonator used.

8.2. Application Circuit - (2)

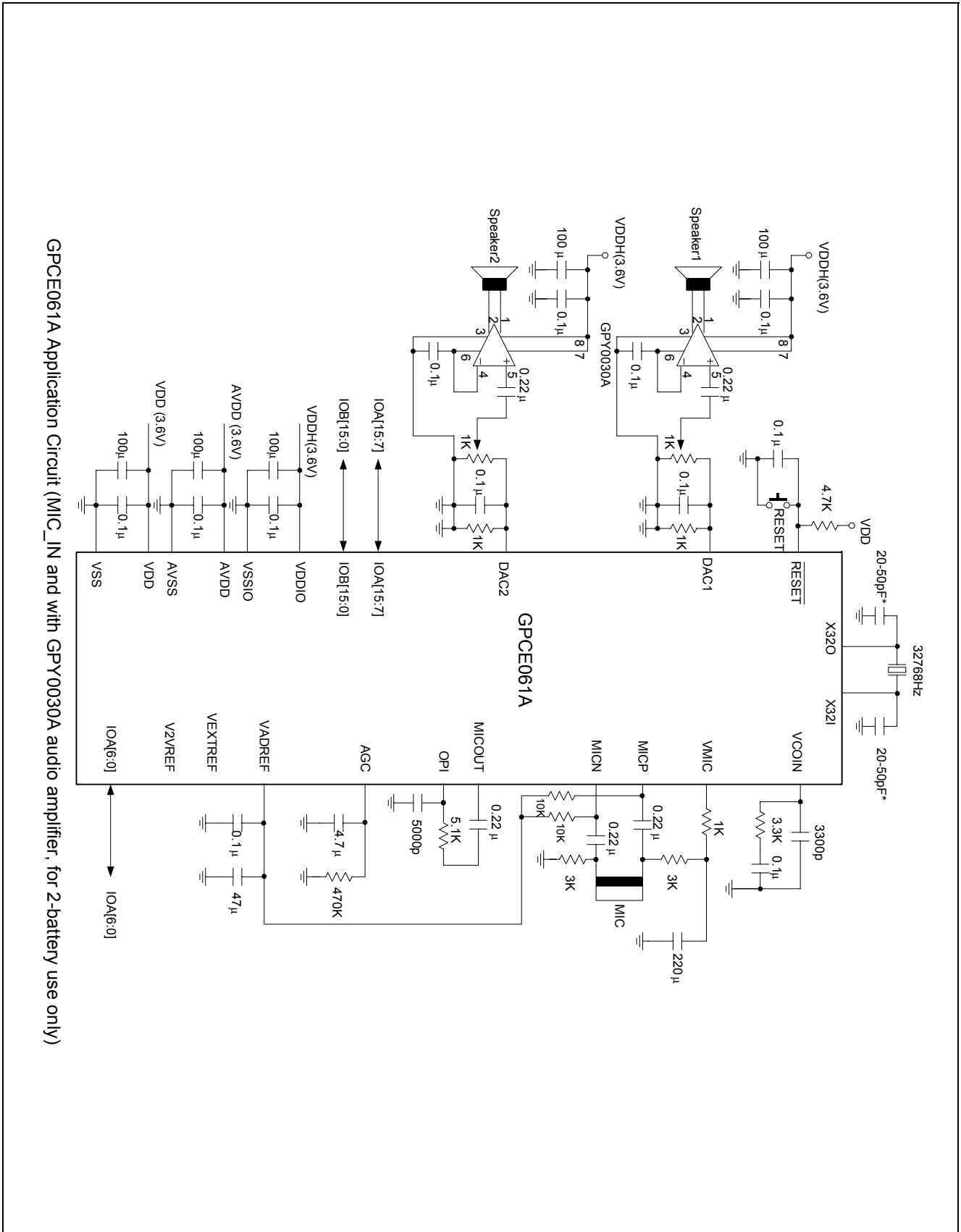

Note*: These capacitor values are for design guidance only. Different capacitor values may be required for different crystal/resonator used.

8.3. Application Circuit - (3)

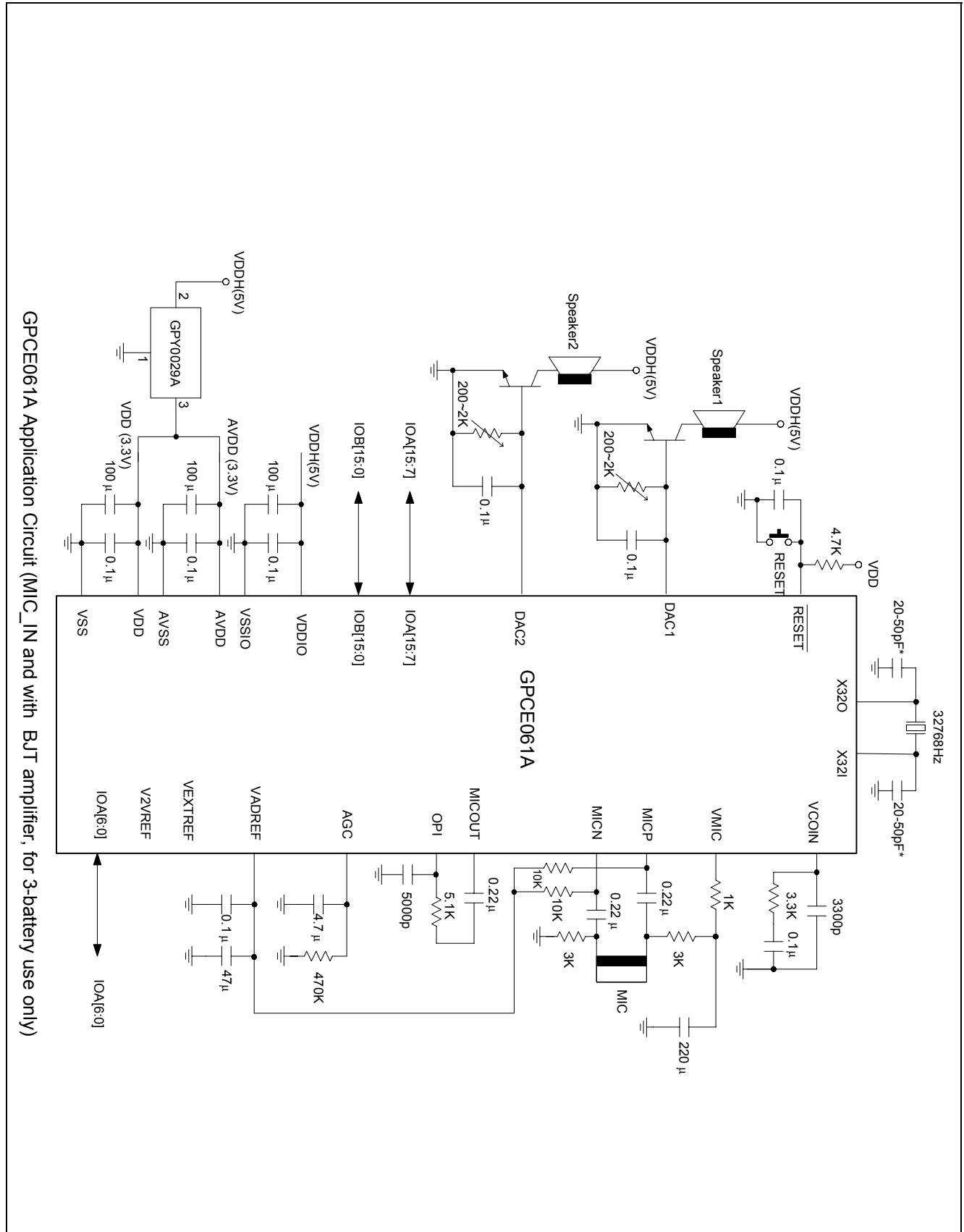

Note*: These capacitor values are for design guidance only. Different capacitor values may be required for different crystal/resonator used.

8.4. Application Circuit - (4)

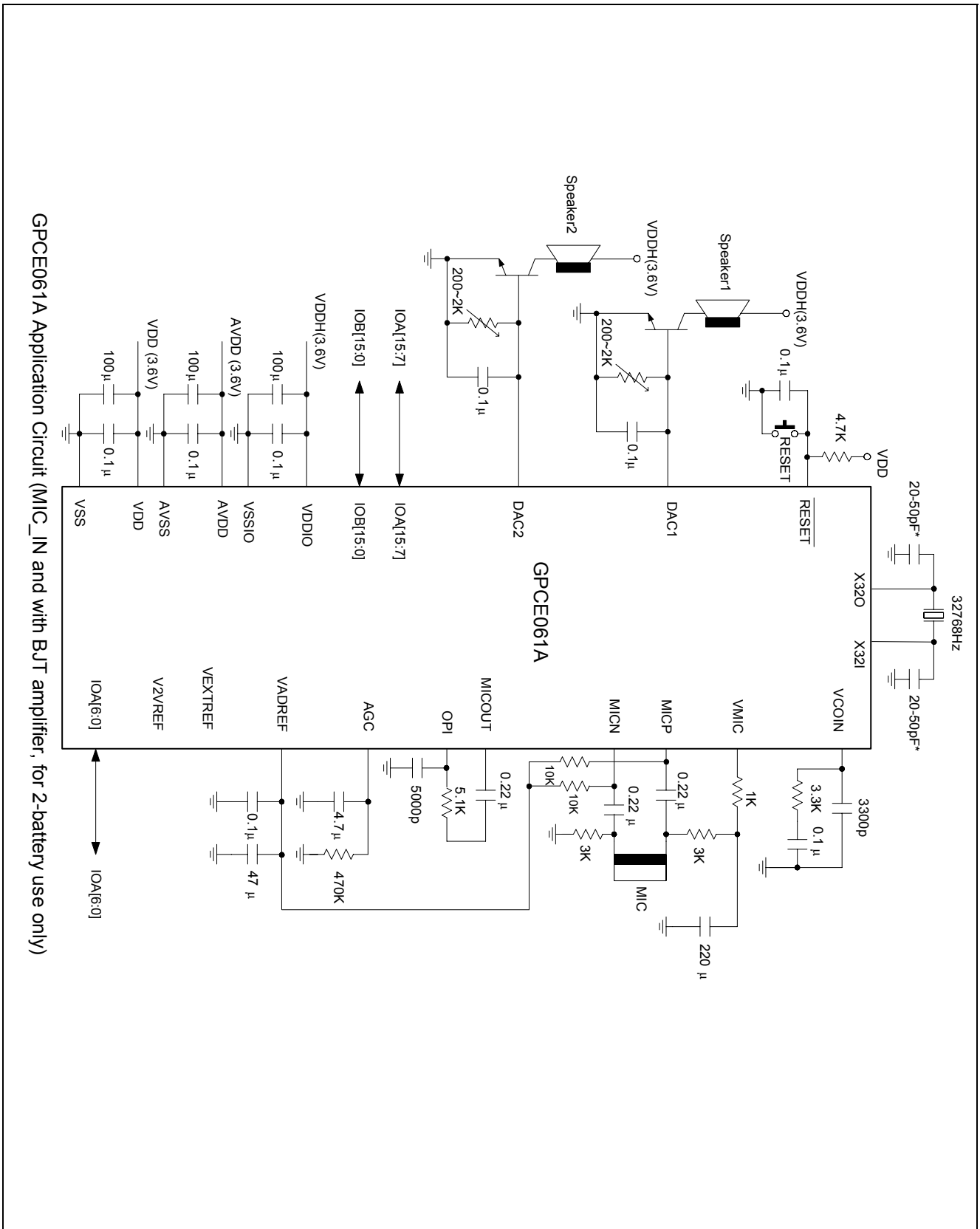

Note*: These capacitor values are for design guidance only. Different capacitor values may be required for different crystal/resonator used.

8.5. Application Circuit - (5)

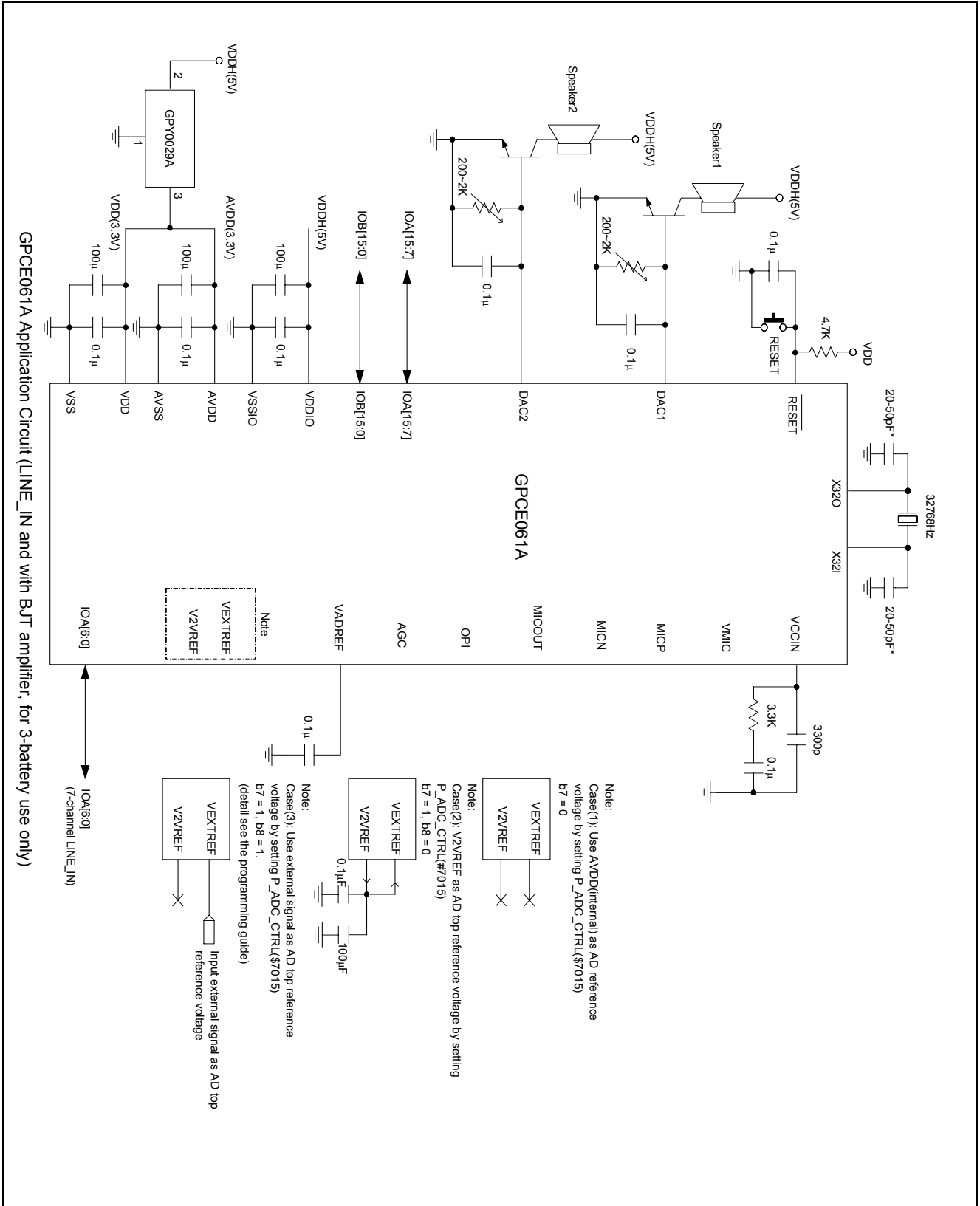

8.6. Application Circuit - (6)

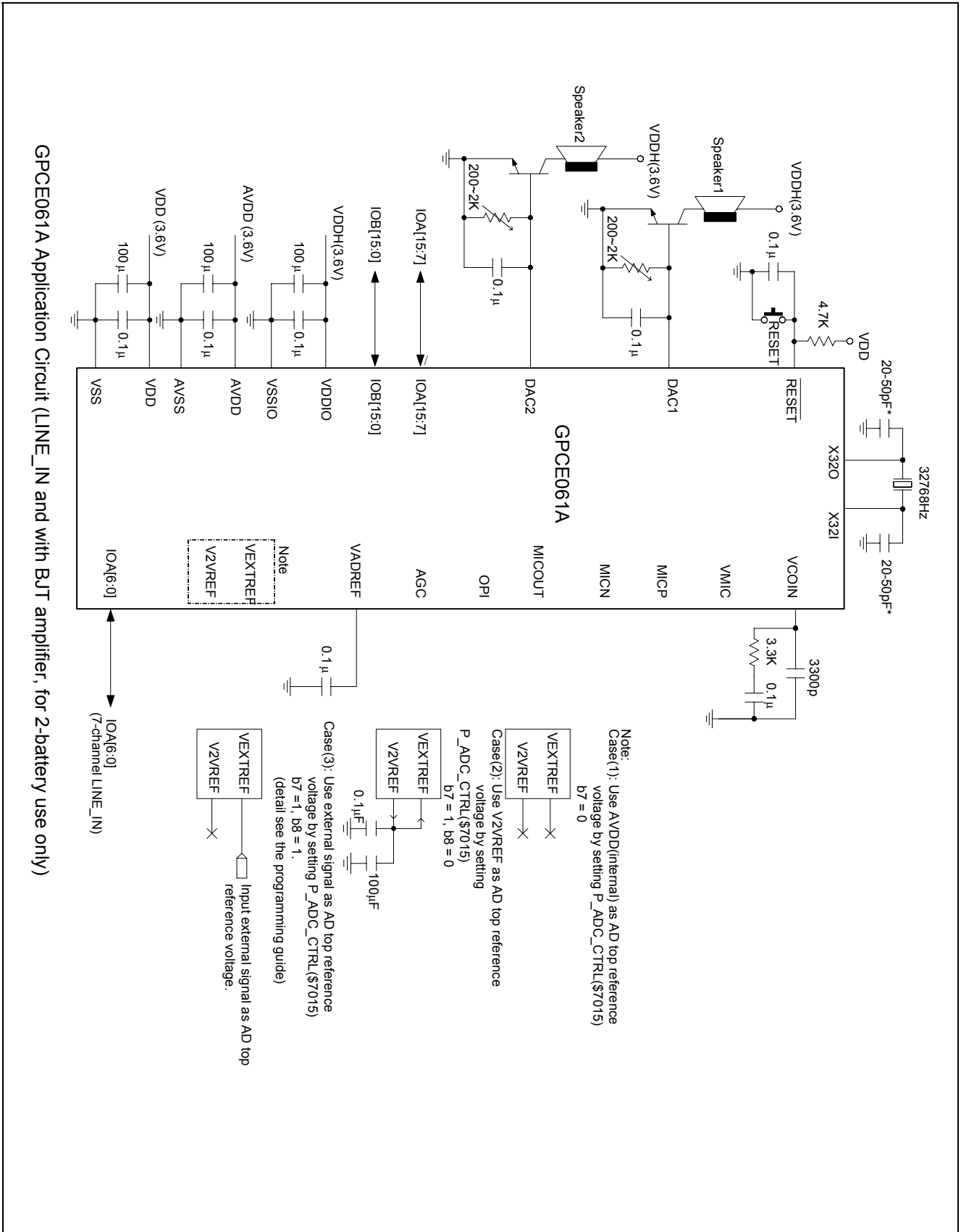

Note*: These capacitor values are for design guidance only. Different capacitor values may be required for different crystal/resonator used.

8.7. Application Circuit - (7)

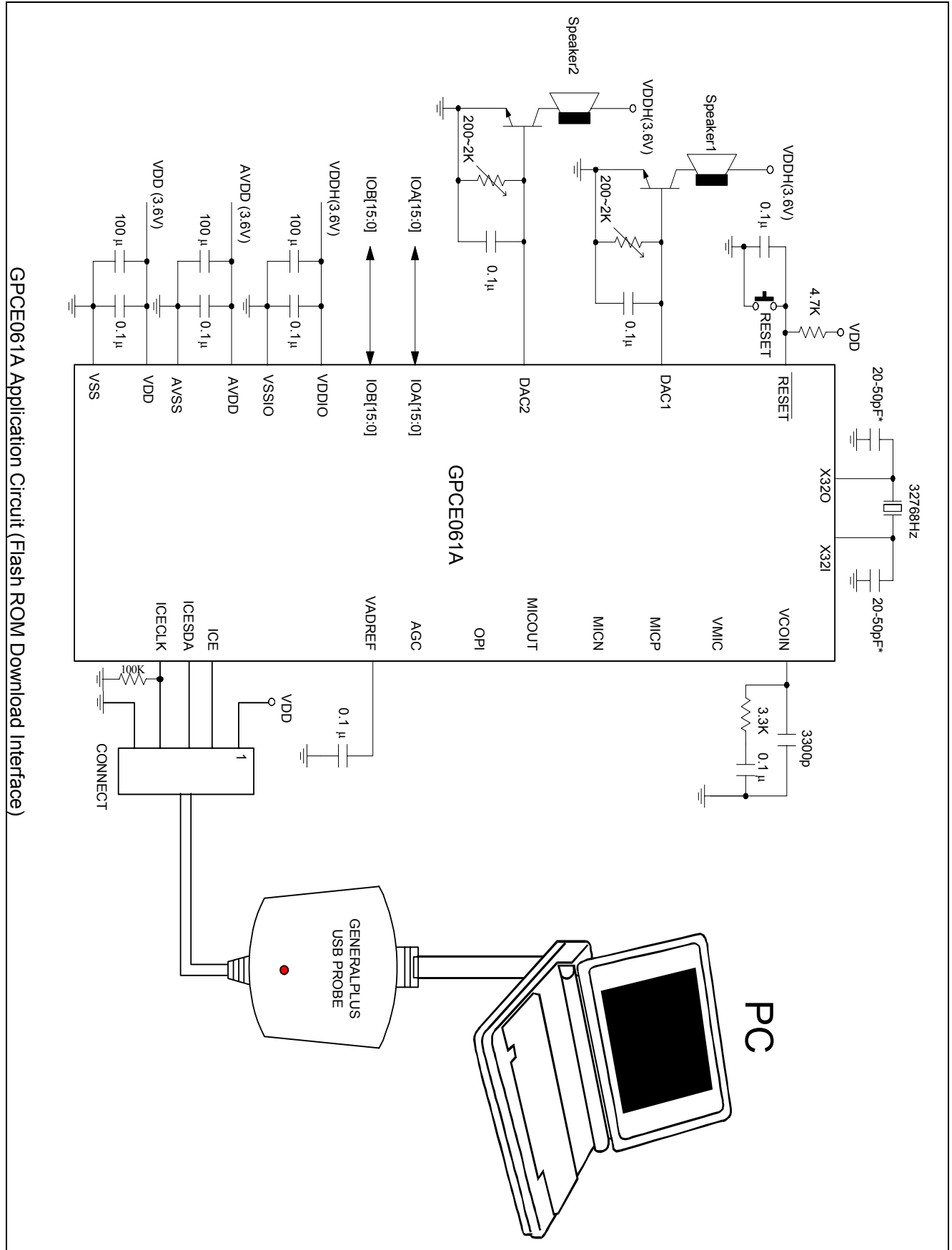

GPCE061A Application Circuit (Flash ROM Download Interface)

Note*: These capacitor values are for design guidance only. Different capacitor values may be required for different crystal/resonator used.

9. PACKAGE/PAD LOCATIONS

9.1. Ordering Information

Product Number	Package Type
GPCE061A-NnnV-C	Chip form
GPCE061A-NnnV-HL04n-W	Green Package form - LQFP 80

Note1: Code number is assigned for customer.

Note2: Code number (N = A - Z or 0 - 9, nn = 00 - 99); version (V = A - Z).

Note3: HL04n-W, HL04 is assign for LQFP80, n is assign for customer, W is watch dog bonding option (W=0 enable, W=1 disable).

9.2. Package Information

9.2.1. LQFP 80

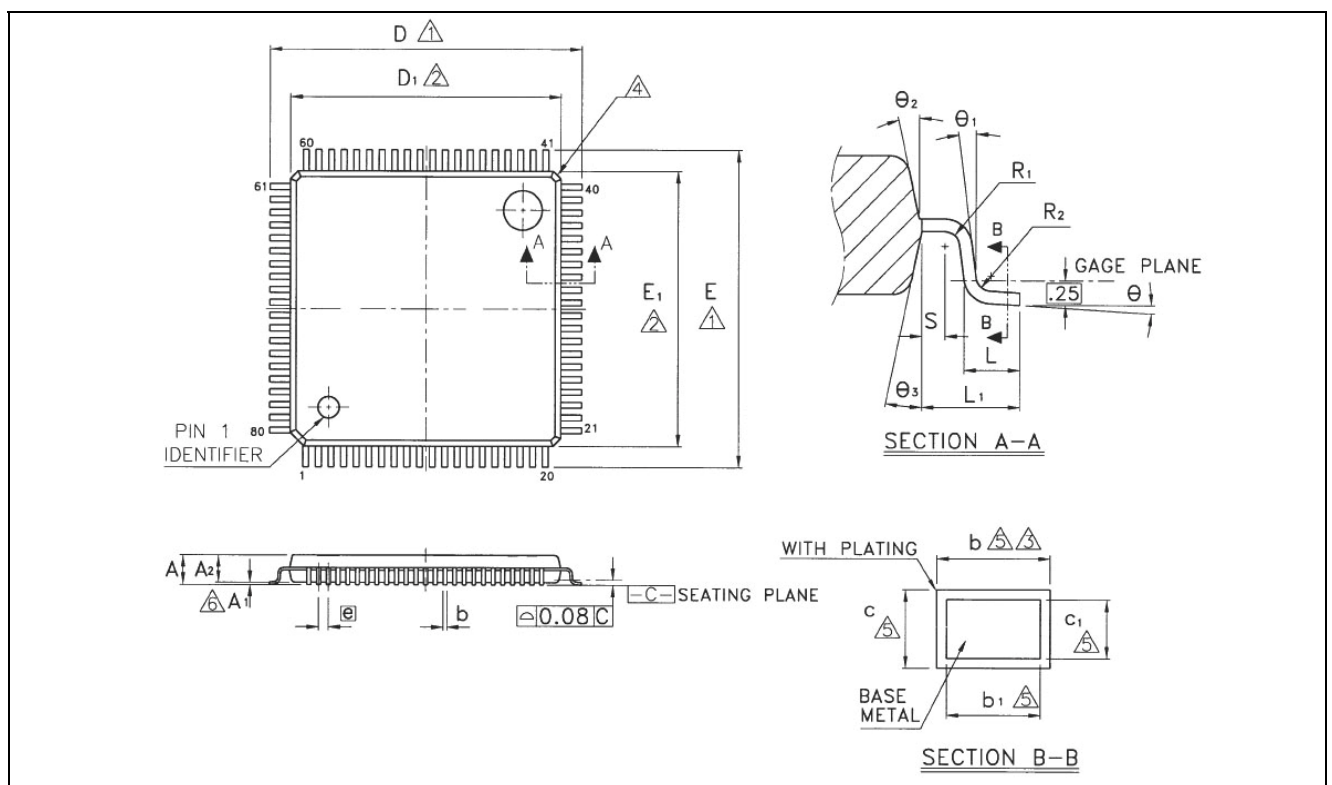

Symbol	Dimension in inch		
	Min.	Typ.	Max.
A	-	-	0.063
A1	0.002	-	0.006
A2	0.053	0.055	0.057
b	0.007	0.009	0.011
b1	0.007	0.008	0.009
c	0.004	-	0.008
c1	0.004	-	0.006
D	0.551 BSC		
D1	0.472 BSC		
E	0.551 BSC		
E1	0.472 BSC		
e	0.020 BSC		

Symbol	Dimension in inch		
	Min.	Typ.	Max.
L	0.018	0.024	0.030
L1	0.039 REF		
R1	0.003	-	-
R2	0.003	-	0.008
S	0.008	-	-
θ	0°	3.5°	7°
θ_1	0°	-	-
θ_2	11°	12°	13°
θ_3	11°	12°	13°

PAD No.	PAD Name	PAD No.	PAD Name
1	X32O	34	IOA6
2	X32I	35	IOA7
3	TEST	36	VSSIO
4	N/C	37	VSSIO
5	VDD	38	VDDIO
6	N/C	39	VDDIO
7	ICE	40	IOA8
8	ICECLK	41	N/C
9	ICESDA	42	N/C
10	VSS	43	IOA9
11	PVIN	44	IOA10
12	DAC1	45	IOA11
13	DAC2	46	IOA12
14	V2VREF	47	IOA13
15	AVSS	48	IOA14
16	AGC	49	IOA15
17	OPI	50	N/C
18	MICOUT	51	N/C
19	MICN	52	VSSIO
20	PFUSE	53	N/C
21	MICP	54	SLEEP
22	VADREF	55	IOB15
23	VEXTREF	56	IOB14
24	AVDD	57	IOB13
25	VMIC	58	IOB12
26	N/C	59	IOB11
27	VSS	60	NC
28	IOA0	61	N/C
29	IOA1	62	N/C
30	IOA2	63	IN/C
31	IOA3	64	VDDIO
32	IOA4	65	IOB10
33	IOA5	66	IOB9

PAD No.	PAD Name	PAD No.	PAD Name
67	IOB8	74	IOB1
68	IOB7	75	IOB0
69	IOB6	76	RESET
70	IOB5	77	N/C
71	IOB4	78	VDD
72	IOB3	79	VCOIN
73	IOB2	80	VSS

10. TABLE OF GPCE061/060/040 COMPARISON

The information in this table is the different from GPCE061/060/040.

Item	GPCE040A	GPCE060A	GPCE061A
Working Voltage	3.0V ~ 3.6V @ 49.152MHz 2.4V ~ 3.6V @ 40.96MHz, 32.768MHz, 24.576MHz, 20.48MHz		3.0V ~ 3.6V
IO Working Voltage	2.4V ~ 5.5V		3.0V ~ 5.5V
Memory size	24K Words ROM	32K Words ROM	32K Words Flash Memory
MICN/MICP 10K Ω pull up resistors	Built in (ref. the GPCE060A/040A datasheet application circuit 1)		Using external resistors (ref. GPCE061A datasheet application circuit 1)
Pin 7 in LQFP80 package	NC (ref LQFP80 package)		ICE , the ICE Enable (ref LQFP80 package)
Pin 8 in LQFP80 package	Ground reference for I/O and logic pins (VSS) (ref LQFP80 package)		ICECLK , the ICE serial interface clock. 100K Ω pull low resistor is necessary to prevent current leakage. (ref LQFP80 package)
Pin 9 in LQFP80 package	NC (ref LQFP80 package)		ICESDA , the ICE serial interface data
Pin20,11 in LQFP80 package (Pfuse, Pvin)	NC (ref LQFP80 package)		NC in normal mode, for security using (ref. GPCE061A datasheet)

11. DISCLAIMER

The information appearing in this publication is believed to be accurate.

Integrated circuits sold by Generalplus Technology are covered by the warranty and patent indemnification provisions stipulated in the terms of sale only. GENERALPLUS makes no warranty, express, statutory implied or by description regarding the information in this publication or regarding the freedom of the described chip(s) from patent infringement. FURTHER, GENERALPLUS MAKES NO WARRANTY OF MERCHANTABILITY OR FITNESS FOR ANY PURPOSE. GENERALPLUS reserves the right to halt production or alter the specifications and prices at any time without notice. Accordingly, the reader is cautioned to verify that the data sheets and other information in this publication are current before placing orders. Products described herein are intended for use in normal commercial applications. Applications involving unusual environmental or reliability requirements, e.g. military equipment or medical life support equipment, are specifically not recommended without additional processing by GENERALPLUS for such applications. Please note that application circuits illustrated in this document are for reference purposes only.

12. REVISION HISTORY

Date	Revision #	Description	Page
OCT. 01, 2013	1.5	Add COMAIR logo to the cover page	
NOV. 18, 2011	1.4	Modify 8.7 Application Circuit - (7).	23
OCT. 13, 2010	1.3	Modify 3.FEATURES.	4
MAY 23, 2008	1.2	Modify 8. APPLICATION CIRCUITS.	17-23
JUL. 11, 2006	1.1	1. Modify the 9.2 Ordering Information.	24
		2. Delete the 9.3.2 PLCC84.	25
		3. Modify the 8. APPLICATION CIRCUITS.	17-23
DEC. 19, 2005	1.0	Original Note: The GPCE061A data sheet v1.0 is a continued version of SPCE061A data sheet v0.8.	31