

DATA SHEET



GPCH8512A

8-Channel Sound Controller

Dec. 09, 2008

Version 1.3

GENERALPLUS TECHNOLOGY INC. reserves the right to change this documentation without prior notice. Information provided by GENERALPLUS TECHNOLOGY INC. is believed to be accurate and reliable. However, GENERALPLUS TECHNOLOGY INC. makes no warranty for any errors which may appear in this document. Contact GENERALPLUS TECHNOLOGY INC. to obtain the latest version of device specifications before placing your order. No responsibility is assumed by GENERALPLUS TECHNOLOGY INC. for any infringement of patent or other rights of third parties which may result from its use. In addition, GENERALPLUS products are not authorized for use as critical components in life support devices/systems or aviation devices/systems, where a malfunction or failure of the product may reasonably be expected to result in significant injury to the user, without the express written approval of Generalplus.

Table of Contents

	<u>PAGE</u>
1. GENERAL DESCRIPTION	3
2. FEATURES	3
3. APPLICATION FIELD	3
4. BLOCK DIAGRAM	4
5. SIGNAL DESCRIPTIONS	5
5.1. PAD ASSIGNMENT	6
5.2. PIN MAP - LQFP 128	7
5.3. PIN MAP - LQFP 44	8
6. FUNCTIONAL DESCRIPTIONS	9
6.1. SRAM	9
6.2. ROM	9
6.3. LOW VOLTAGE RESET	9
6.4. INTERRUPT	9
6.5. I/O	9
6.5.1. I/O configuration	9
6.6. TIMER/COUNTER (TIMER A/TIMER B/TIMER C)	10
6.7. SLEEP, WAKEUP AND WATCHDOG	10
6.7.1. Sleep and Wakeup	10
6.7.2. Watchdog	10
6.8. SPEECH AND DAC	10
7. ELECTRICAL SPECIFICATIONS	11
7.1. ABSOLUTE MAXIMUM RATINGS	11
7.2. DC CHARACTERISTICS (VDD5/VDD5_4 = 3.0V, T _A = 25°C)	11
7.3. DC CHARACTERISTICS (VDD5/VDD5_4 = 5.0V, T _A = 25°C)	11
7.4. DAC CHARACTERISTICS (VDD5 = 3.0V, T _A = 25°C)	12
7.5. REGULATOR CHARACTERISTICS (T _A = 25°C)	12
7.6. THE RELATIONSHIPS BETWEEN THE R _{OSC} AND THE F _{OSC}	12
7.7. THE RELATIONSHIPS BETWEEN THE F _{OSC} AND THE I _{OP}	12
7.8. THE RELATIONSHIPS BETWEEN THE I _{OP} AND THE V _{DD}	13
7.8.1. F _{CPU} = 7.159 MHz. V _{DD} = VDD5_4	13
7.9. THE RELATIONSHIPS BETWEEN THE I _{OH} AND THE V _{DD}	13
7.9.1. V _{OH} = 0.9V _{DD}	13
7.10. THE RELATIONSHIPS BETWEEN THE I _{OL} AND THE V _{DD}	13
7.10.1. V _{OL} = 0.1V _{DD}	13
8. APPLICATION CIRCUITS	14
8.1. GPCH8512A APPLICATION CIRCUIT WITH R _{OSC} OPTION	14
8.2. GPCH8512A APPLICATION CIRCUIT WITH CRYSTAL OPTION	15
8.3. CURRENT MODE DAC SPEAKER DRIVER	16
9. PACKAGE/PAD LOCATIONS	17
9.1. ORDERING INFORMATION	17
9.2. PACKAGE INFORMATION	17
9.2.1. LQFP 128-QL09	17
9.2.2. LQFP 44-QL01	18
10. DISCLAIMER	19
11. REVISION HISTORY	20

8-BIT SOUND CONTROLLER

1. GENERAL DESCRIPTION

The GPCH8512A embedded with an 8-bit processor, 512K bytes ROM chip, 512 bytes working SRAM, 3 sets of 12-bit timers, 24 general I/Os, and 1 set of 12-bit DAC. The microprocessor can implement software based on audio processing, functional control and others. For audio processing, melody and speech can be mixed into one output. The GPCH8512A implement a high performance SPU voice engine to achieve 8 channel voices with ADPCM/PCM. It operates over a wide voltage range from 2.4V through 5.5V, and it includes a Low Voltage Reset to assure system operating appropriately under low voltage condition. In addition, GPCH8512A provides sleep mode for power savings. It can be awoken from sleep mode by interrupt source or by IOA's state change.

2. FEATURES

- Working Voltage: 2.4V - 5.5V
- CPU Speed: 7.159MHz.
- $F_{OSC} = 14.318\text{MHz}$ (2 x CPU clock)
- ROM Size: 512k bytes
- RAM Size: 512 bytes. (Programmable RAM 384 bytes)
- Three 12-bit timers/counters, TMA/TMB/TMC (Programmable and Auto Reload)
- Sleep mode to reduce power
- Key change wake up function
- 10 IRQ & 6 NMI Interrupts
- Watchdog Function
- Low Voltage Reset: 2.2V
- 24 general I/Os, including 8 general/special I/Os (All bit programmable)
- 8-bit I/O with high sink current(20mA) for LED application
- IOA with 1M pull low function to prevent current leakage from error key touch
- One 12-bit DAC outputs (D/A output: 4mA/channel)
- SPU(Sound Processing Unit) engine can output audio data of 15-bit resolution with 12-bit DAC to perform high quality sound
- IR PWM Output
- 8-channel SPU engine with ADPCM/PCM wave table
- Tone color (Speech) with ADPCM algorithm to save memory usage

3. APPLICATION FIELD

- Talking Instrument Controller
- General Music Synthesizer
- Industrial Controller
- High End Toy Controller
- Intelligent Education Toys
- And more

4. BLOCK DIAGRAM

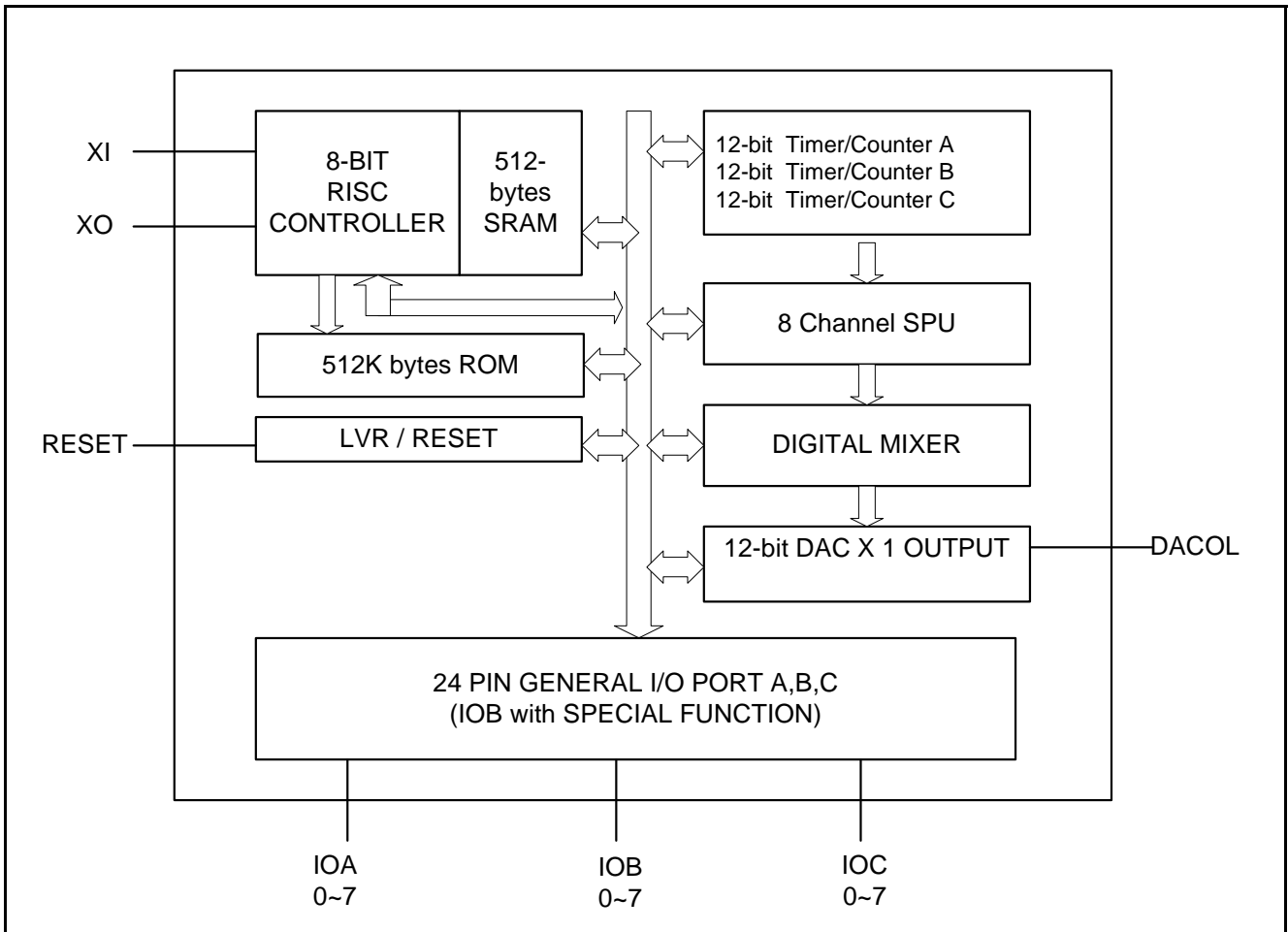

5.SIGNAL DESCRIPTIONS

Name	PIN No.	LQFP 128 PIN No.	LQFP 44 PIN No.	Type	Description	Pull hi/low/float
IO PORT						
IOA0~IOA7	40~33	90~83	34~31, -	I/O	Bi-directional IO ports, can be wakeup pins	-
IOB0~IOB7	32~29, 25~22	82~79, 75~72	30~29, -	I/O	Bi-directional IO ports	-
IOC0~IOC7	2~5, 7~10	41~44, 23~26	-, 6~9	I/O	Bi-directional IO ports	-
Clock Related						
XO	19	58	22	O	Oscillator Crystal output	-
XI	18	57	21	I	Oscillator crystal input/ROSC input	Pull-low
Power Pad						
VDD	26	76	26	I	Positive supply for logic (from VDD30)	-
VSS	6, 28	37, 78	28	I	Ground reference for logic and I/O pins	-
VDD5_4, VDD5	11, 27	47, 77	12, 27	I	Positive supply for I/O pins(2.4~5.5 V)	-
VDDDAC3	12	48	13	I	Positive supply for DAC(from VDD30)	-
VSSDAC	14	51	15	I	Ground reference for DAC	-
VDDREG	16	53	17	I	Positive supply for REGULATOR(2.4~5.5 V)	-
VSSREG	17	54	18	I	Ground reference for regulator	-
VDD30	15	52	16	O	3V power output from regulator	-
Others						
RESETB	20	65	23	I	External reset pin(active low)	Pull-hi
TEST	21	66	24	I	Test mode	Pull-low
DACOL	13	50	14	O	Left DAC output	-
SLEEP	1	20	5	O	Sleep indicator	-

5.1. PAD Assignment

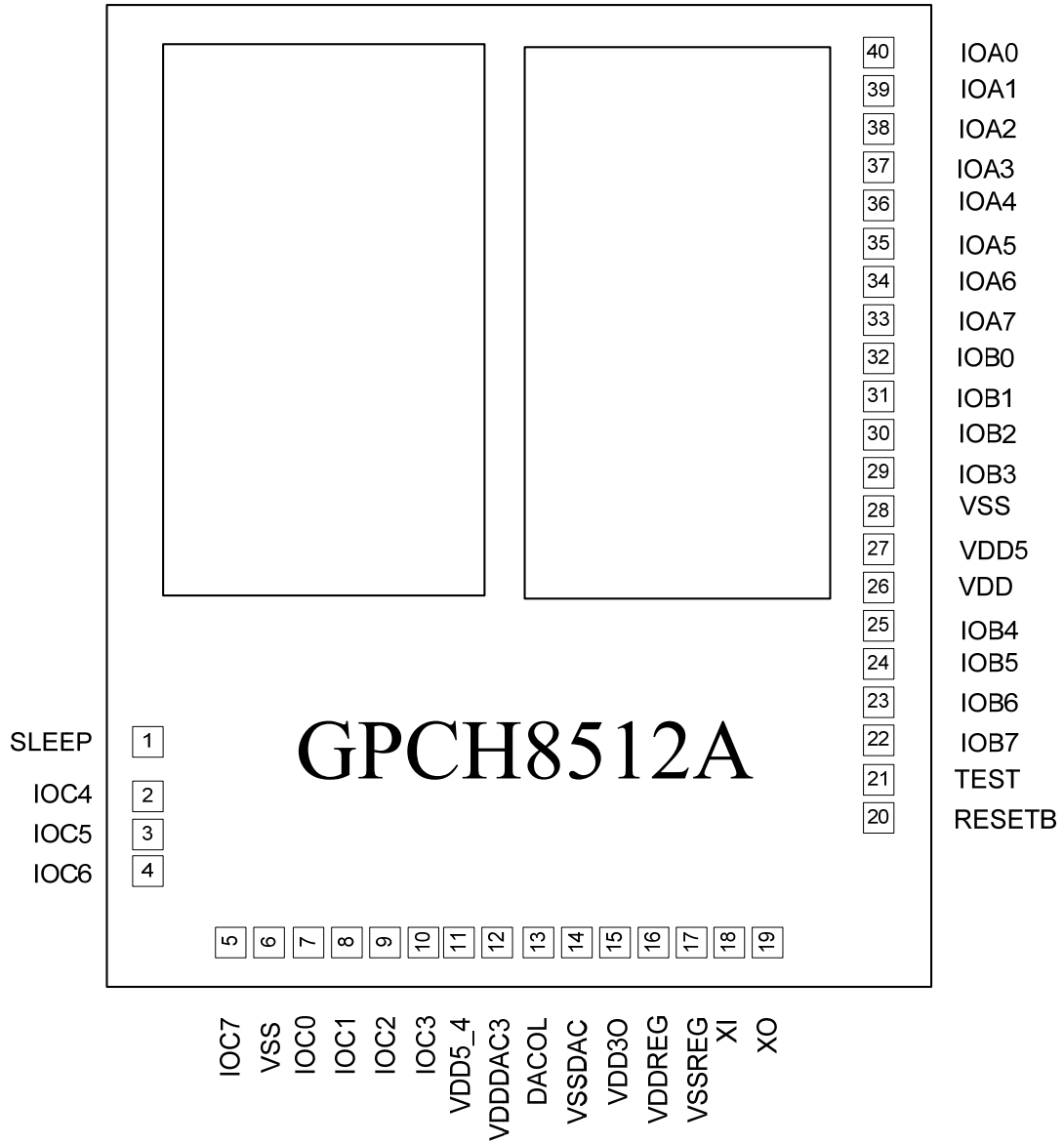

5.2. PIN Map - LQFP 128

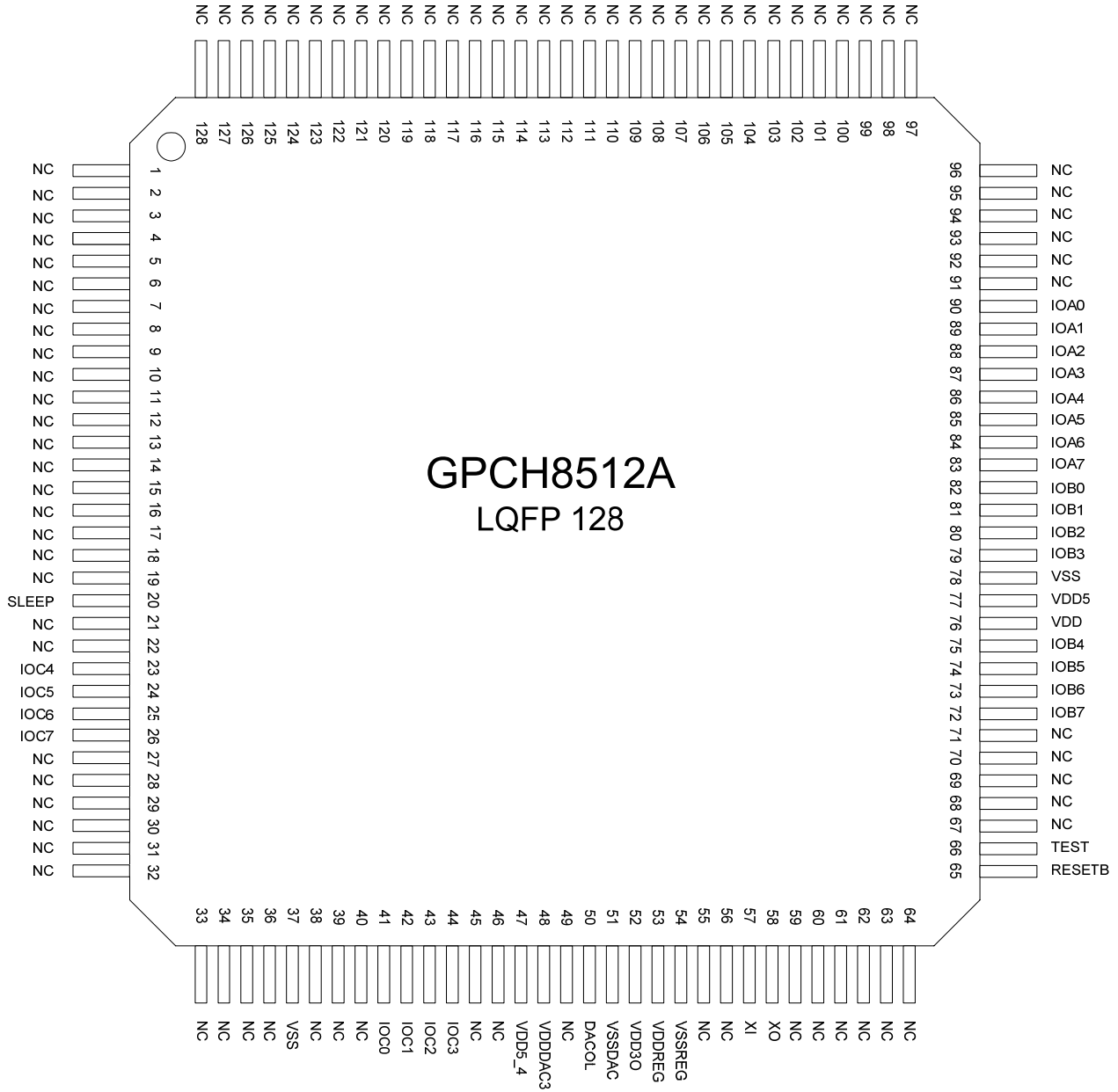

5.3. PIN Map - LQFP 44

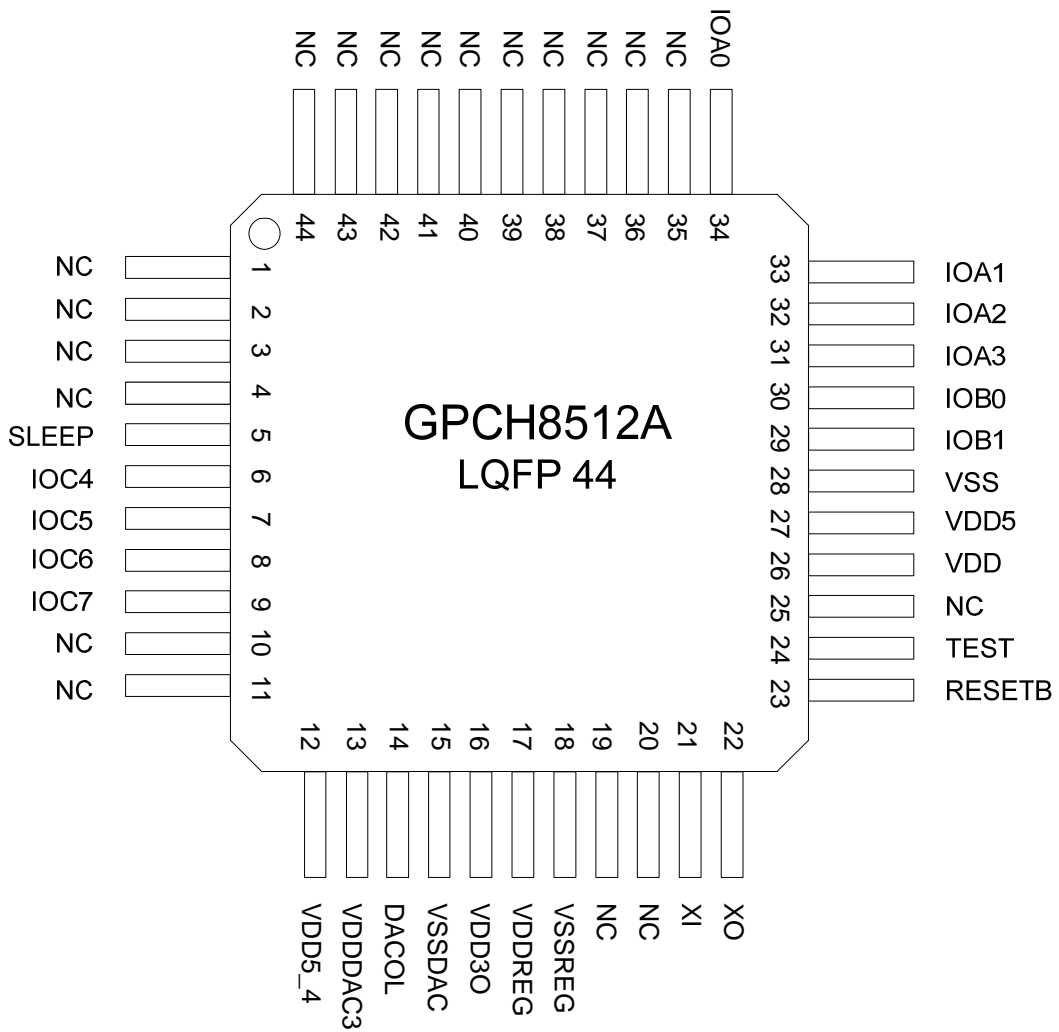

6. FUNCTIONAL DESCRIPTIONS

6.1. SRAM

The 512-byte SRAM (including Stack) area is located in \$000000~\$0002FF.

6.2. ROM

GPCH8512A can be selected to use internal ROM with 512k bytes.

6.3. Low Voltage Reset

The GPCH8512A provides another important feature, Low Voltage Reset (LVR). Without LVR, the CPU may become unstable and malfunctioning when operating voltage drops below 2.2V. It will reset all functions to the initial operational (stable) states when the voltage drops below 2.2V by LVR.

6.4. Interrupt

The GPCH8512A has two interrupt (INT) modes: IRQ (interrupt Request) and NMI (Non-Mask Interrupt Request). The interrupt controller controls 10 IRQs and 6 NMIs. A NMI cannot be interrupted by any other IRQs. An IRQ can be interrupted by a NMI and by a high priority IRQ.

Interrupt Source	Interrupt Name	Priority
Timer A	NMI_TIMER_A	NMI
Timer B	NMI_TIMER_B	NMI
Timer C	NMI_TIMER_C	NMI
CPU_CLOCK/1024	NMI_D1024	NMI
KEY	NMI_KEY	NMI
EXT	NMI_EXT	NMI
TIMER A	IRQ_TIMER_A	IRQ1
TIMER B	IRQ_TIMER_B	IRQ2
TIMER C	IRQ_TIMER_C	IRQ3
CPU_CLOCK/1024	IRQ_D1024	IRQ4
CPU_CLOCK/4096	IRQ_D4096	IRQ5
CPU_CLOCK/262144	IRQ_D262144	IRQ6
CPU_CLOCK/2097152	IRQ_D2097152	IRQ7

Interrupt Source	Interrupt Name	Priority
KEY	IRQ_KEY	IRQ8
EXT	IRQ_EXT	IRQ9
SPU	IRQ_SPU	IRQ10

6.5. I/O

The purpose of input and output ports is to communicate with other devices. Four programmable I/O ports are built-in, including Port A, B, and C. The PortA is a general I/O with programmable wake-up capability. In addition to general I/O function, PortB also offers some special functions in certain pins. Refer to **Special Function in PortB**. PortC0~7 provides large sink current (20mA) for LED application.

6.5.1. I/O configuration

The following diagram represents the I/O schematic.

I/O A, B, C Schematic:

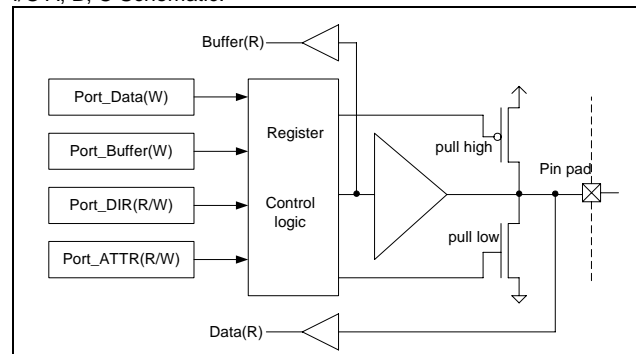

Port_Data and Port_Buffer are written into the same register but read from different nodes. The IOA [7:0] is the key wakeup port. To activate key wakeup function, first latch data on IOA_Data and enable the key wakeup function. Wakeup is triggered when the PortA state is different from first latched data. In addition to a general I/O port, PortB can be assigned to some special functions. A summary of PortB special functions is listed as follows.

Special function in PortB

PortB	Special Function	Function Description	Note
IOB5	PWMO IR	IR carrier frequency output	Refer to Timer/Counter section
IOB6	EXT	External interrupt source	Negative edge trigger INT(default)
	Feedback Output	Works with IOB7 by adding a RC circuit between them to get an OSC to EXT interrupt	-
IOB7	Feedback Input	Schmitt Inverter Input	-

6.6. Timer/Counter (Timer A/Timer B/Timer C)

Three timers are embedded in GPCH8512A, TimerA, B and C. All three timers have the same behavior which includes 12-bit up counter and a preload register and programmable clock source. Timer A can also be the clock source of the software channel.

The clock source of each timer can be set individually. Two clock sources including CPU clock and external clock can be selected individually or combined together for timer's clock source.

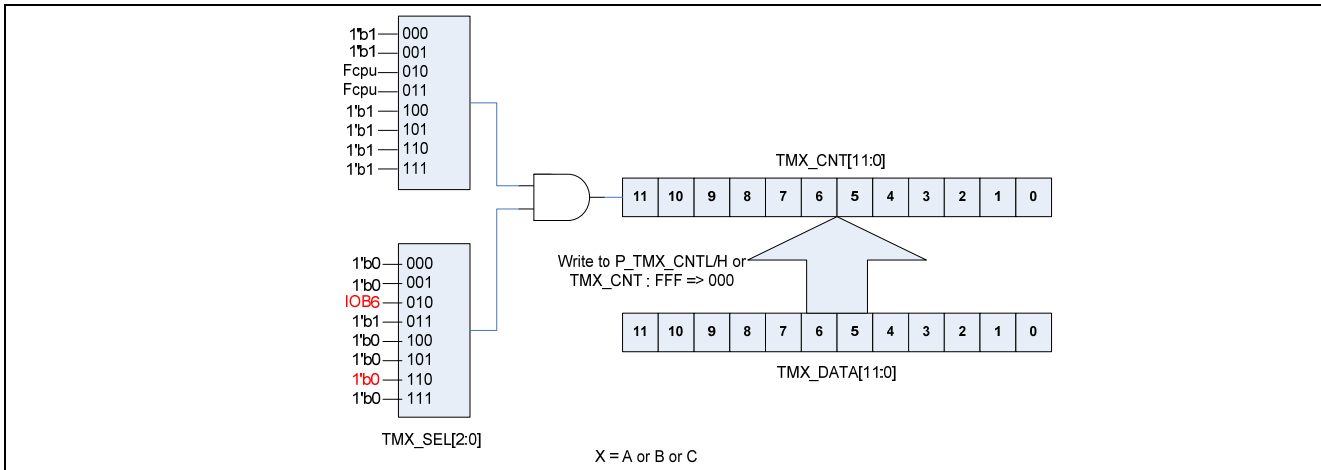

Select	Input 1	Input 2	Function	Comment
000	'1'	'0'	Disable	Disable
001	'1'	'0'	Disable	Disable
010	F _{CPU}	IOB6	Duration count by F _{CPU}	Duration count by F _{CPU}
011	F _{CPU}	'1'	Timer by F _{CPU}	Timer by F _{CPU}
100	'1'	'0'	Disable	Disable
101	'1'	'0'	Disable	Disable
110	'1'	'0'	Disable	Disable
111	'1'	'0'	Disable	Disable

6.7. Sleep, Wakeup and Watchdog

6.7.1. Sleep and Wakeup

Sleep mode is to save power by stopping clock running while device is not in use. When sleep acts, the device runs from operating mode to standby mode. Wake-up from sleep mode means turning back to operating mode.

- 1). Sleep: After power on reset, IC starts working until a sleep command is given. When a sleep signal is accepted, IC will turn off system clock and enter sleep mode.
- 2). Wake-up: While an IRQ/NMI interrupt signal is generated, GPCH8512A is waking up from sleep mode. While wake-up completed, program counter will continue to execute the next command.

6.7.2. Watchdog

The purpose of watchdog is to monitor system's operation normally. Within a certain period, watchdog must be cleared;

otherwise, CPU assumes the program has been running in an abnormal condition and therefore, CPU will reset the system to the initial state and start running the program from program's beginning. It protects the system from incorrect code execution by generating a system reset when the watchdog timer overflows as a result of failure of software to clear the timer within 0.75 seconds. Watchdog function can be removed by option.

6.8. Speech and DAC

The GPCH8512A uses a high performance SPU voice engine to archive 8-channel voice with ADPCM/PCM. The SPU also supports automatic zero-crossing concatenating function. A hardware multiplier is also embedded in this SPU for software usage. The fixed address of RAM area \$0000 - \$007F is designed as address pointers and a data buffer for the 8 channel speech/melody generation. There is one 12-bit D/A with 4mA driving current for audio output.

7. ELECTRICAL SPECIFICATIONS

7.1. Absolute Maximum Ratings

Characteristics	Symbol	Ratings
DC Supply Voltage	V_+	< 7.0V
Input Voltage Range	V_{IN}	-0.5V to $V_+ + 0.5V$
Operating Temperature	T_A	0°C to +60°C
Storage Temperature	T_{STO}	-50°C to +150°C

Note: Stresses beyond those given in the Absolute Maximum Rating table may cause operational errors or damage to the device. For normal operational conditions see DC Electrical Characteristics.

7.2. DC Characteristics (VDD5/VDD5_4 = 3.0V, $T_A = 25^\circ\text{C}$)

Characteristics	Symbol	Limit			Unit	Test Condition
		Min.	Typ.	Max.		
Operating Voltage	VDD	2.4	-	3.6	V	For 2-battery
Operating Current	I_{OP}	-	9	-	mA	$F_{CPU} = 7.0\text{MHz}$, no load, midi playing with inner ROM
Standby Current	I_{STB}	-	-	4.0	μA	VDD5/VDD5_4 = 3.0V
OSC Frequency	F_{OSC}	-	-	15	MHz	VDD5/VDD5_4 = 3.0V
Input High Level	V_{IH}	0.7 VDD	-	VDD	V	-
Input Low Level	V_{IL}	VSS	-	0.3VDD	V	-
Audio Output Current	I_{AUD}	-	-2.0	-	mA	-
Output High Current	I_{OH}	-4.3	-	-	mA	VDD5/VDD5_4 = 3.0V, $V_{OH} = 2.7V$
Output Low Current (IOA7:0, IOB7:0)	I_{OL1}	4.8	-	-	mA	VDD5/VDD5_4 = 3.0V, $V_{OL} = 0.3V$
Output Low Current (IOC7:0)	I_{OL2}	11	-	-	mA	VDD5/VDD5_4 = 3.0V, $V_{OL} = 0.3V$
Input Pull-Low Resistor (PA7:0)	R_{PL}	-	1500	-	K Ω	$V_{IN} = VDD5/VDD5_4$
Input Pull-High Resistor (PA7:0, PB7:0, PC7:0)	R_{PH}	-	180	-	K Ω	$V_{IN} = VSS$

7.3. DC Characteristics (VDD5/VDD5_4 = 5.0V, $T_A = 25^\circ\text{C}$)

Characteristics	Symbol	Limit			Unit	Test Condition
		Min.	Typ.	Max.		
Operating Voltage	VDD	3.6	-	5.5	V	For 3-battery
Operating Current	I_{OP}	-	10	-	mA	$F_{CPU} = 7.0\text{MHz}$, no load, midi playing with inner ROM
Standby Current	I_{STB}	-	-	5.0	μA	VDD5/VDD5_4 = 5.0V
OSC Frequency	F_{OSC}	-	-	15	MHz	VDD5/VDD5_4 = 5.0V
Input High Level	V_{IH}	0.7 VDD	-	VDD	V	-
Input Low Level	V_{IL}	VSS	-	0.3VDD	V	-
Audio Output Current	I_{AUD}	-	-4	-	mA	-
Output High Current	I_{OH}	-11.0	-	-	mA	VDD5/VDD5_4 = 5.0V, $V_{OH} = 4.5V$
Output Low Current (IOA7:0, IOB7:0)	I_{OL1}	11	-	-	mA	VDD5/VDD5_4 = 5.0V, $V_{OL} = 0.5V$

Characteristics	Symbol	Limit			Unit	Test Condition
		Min.	Typ.	Max.		
Output Low Current (IOC7:0)	I_{OL2}	24	-	-	mA	VDD5/VDD5_4 = 5.0V, $V_{OL} = 0.5V$
Input Pull-Low Resister (PA7:0)	R_{PL}	-	810	-	K Ω	VIN = VDD5/VDD5_4
Input Pull-High Resister (PA7:0, PB7:0, PC7:0)	R_{PH}	-	105	-	K Ω	VIN = VSS

7.4. DAC Characteristics (VDD5 = 3.0V, $T_A = 25^\circ C$)

Characteristics	Symbol	Unit			Unit
		Min.	Typ.	Max.	
Resolution of DAC	RESO	-	-	12	bit
THD+N (f=1kHz)	SNR	-	0.1	-	%
Noise at No Signal	-	-	-84	-	dBr A
Dynamic Range(-60dB)	-	-	-77	-	dBr A
Sample Rate	F_s	-	-	400K	Hz

7.5. Regulator Characteristics ($T_A = 25^\circ C$)

Characteristics	Symbol	Unit			Unit
		Min.	Typ.	Max.	
Input Voltage	VREGI	2.4	4.5	5.5	V
Maximum Current Output	IREGO	-	-	30	mA
Output Voltage	VREGO	2.4	3	3.3	V
Standby Current	IRGES	-	2.5	-	μA

7.6. The Relationships between the R_{OSC} and the F_{OSC}

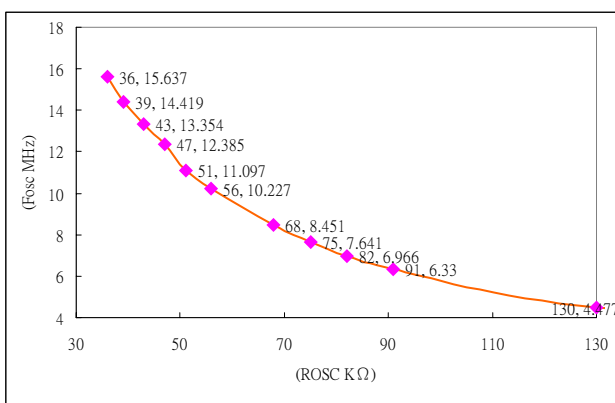

7.7. The Relationships between the F_{OSC} and the I_{OP}

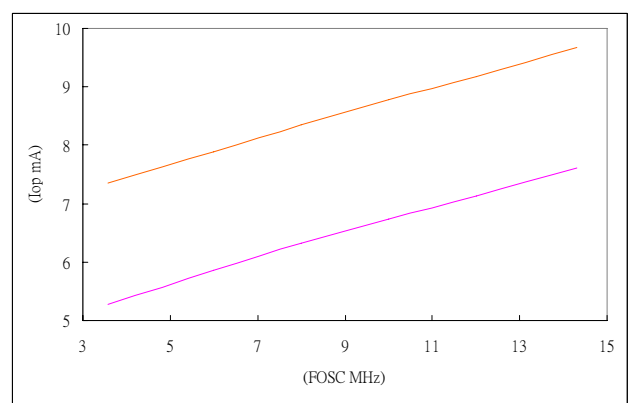

7.8. The Relationships between the I_{OP} and the V_{DD}

7.8.1. $F_{CPU} = 7.159 \text{ MHz}$. $V_{DD} = V_{DD5_4}$

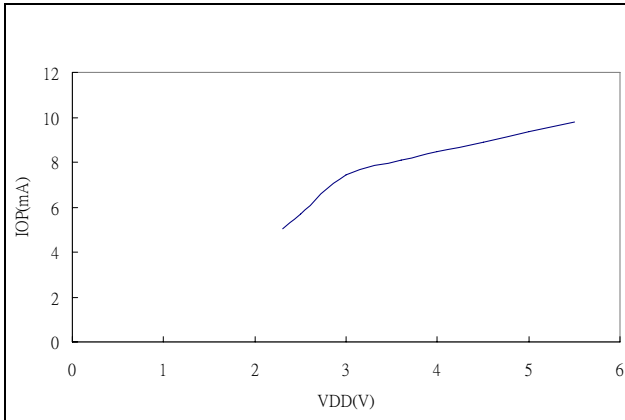

7.10. The Relationships between the I_{OL} and the V_{DD}

7.10.1. $V_{OL} = 0.1V_{DD}$

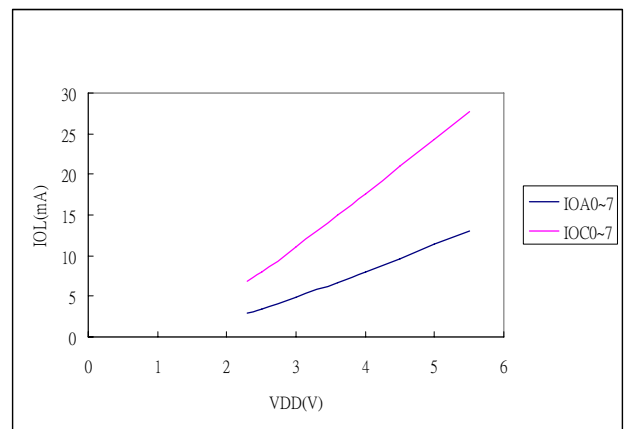

7.9. The Relationships between the I_{OH} and the V_{DD}

7.9.1. $V_{OH} = 0.9V_{DD}$

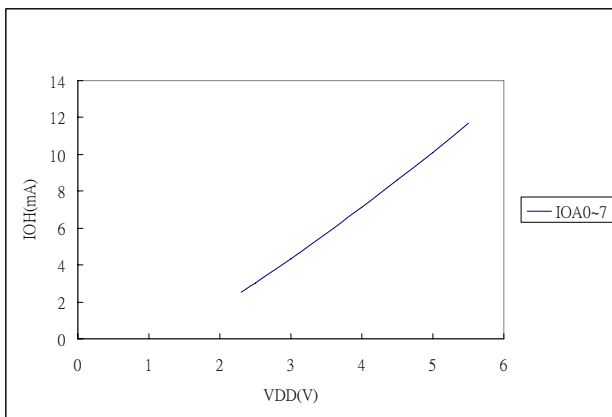

8. APPLICATION CIRCUITS

8.1. GPCH8512A Application Circuit with Rosc Option

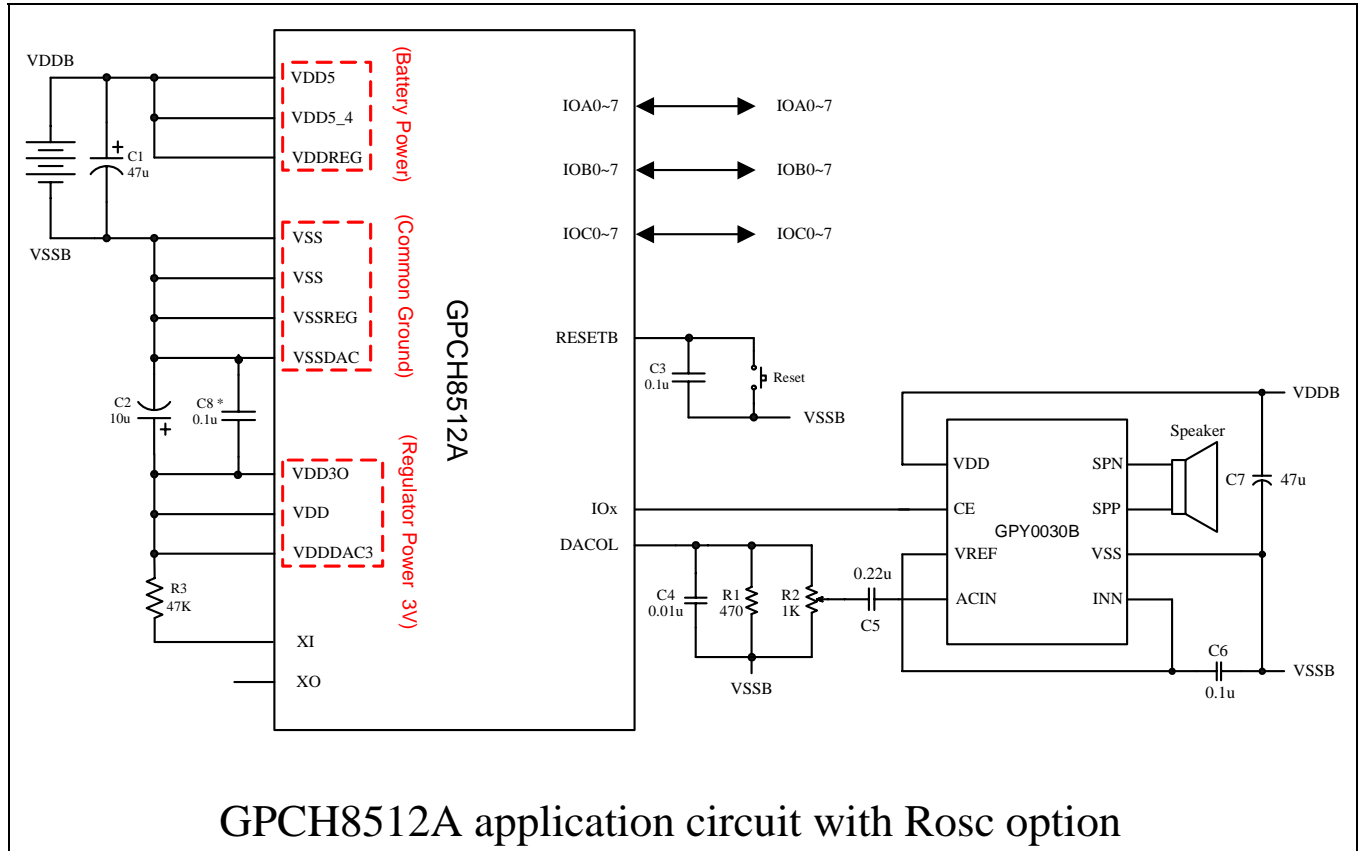

Note*: This capacitor can be removed if there is good power line layout on PCB that no harm to sound quality.

Note: Important note to power connection:

- Battery or Power supply connects to VDDB (including VDDREG, VDD5 and VDD5_4, 2.4V ~ 5.5V)
- VDD30 is internal regulator output that supplies power to VDD, VDDDAC3, etc. Connect VDD30, VDD and VDDDAC3 all together.
- VDDB should NOT be connected to VDD30, VDD, VDDDAC3, etc.
- The built-in regulator can NOT be disabled, so user should NOT bypass this regulator.
- Recommended capacitor placement for power distribution on PCB: C1 close to battery, C2 close to VDD30 pad and C8 close to VDDDAC3 pad.

8.2. GPCH8512A Application Circuit with Crystal Option

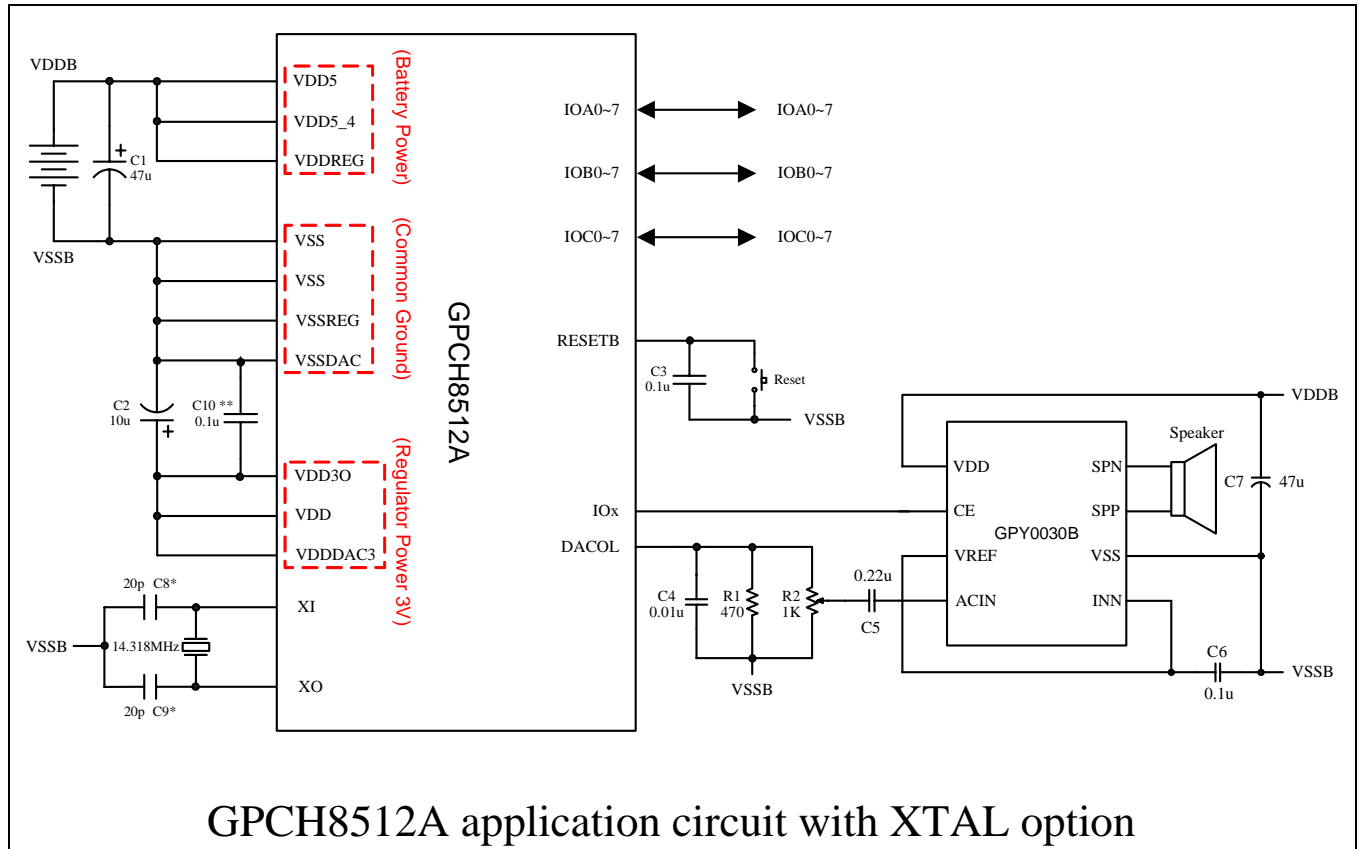

Note*: These capacitor values are for design guidance only. Different capacitor values may be required for different crystal/resonator used.

Note:** This capacitor can be removed if there is good power line layout on PCB that no harm to sound quality.

Note: Important note to power connection:

- Battery or Power supply connects to VDDB (including VDDREG, VDD5 and VDD5_4, 2.4V ~ 5.5V)
- VDD3O is internal regulator output that supplies power to VDD, VDDDAC3, etc. Connect VDD3O, VDD and VDDDAC3 all together.
- VDDB should NOT be connected to VDD3O, VDD, VDDDAC3, etc.
- The built-in regulator can NOT be disabled, so user should NOT bypass this regulator.
- Recommended capacitor placement for power distribution on PCB: C1 close to battery, C2 close to VDD3O pad and C10 close to VDDDAC3 pad.

8.3. Current Mode DAC Speaker Driver

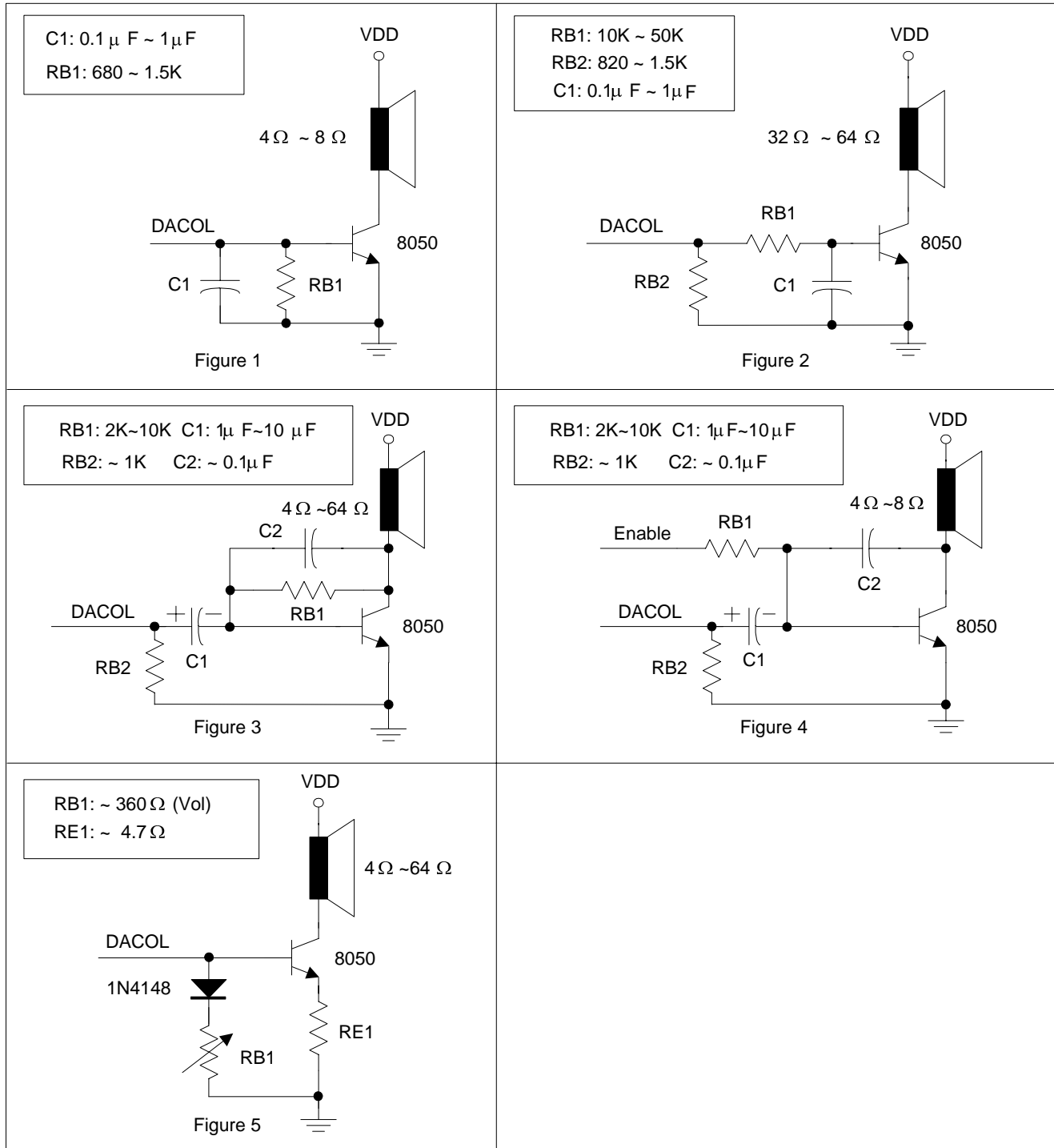

Figure 1: The simplest CKT uses with low impedance speaker. It has high operation current, but the cost is the cheapest.

Figure 2: It is the same as Figure 1 but a high impedance speaker is used.

Figure 3: The CKT has low pass filter. It can provide higher speech quality, but it always takes high operation current.

Figure 4: Improved version of Figure 3. The standby current can be controlled by enable pin.

Figure 5: The current mirror mode. It is able to control the volume. In addition, it has more stable and lower operation current than Figure 1-3.

9. PACKAGE/PAD LOCATIONS

9.1. Ordering Information

Product Number	Package Type
GPCH8512A-NnnV-C	Chip form
GPCH8512A-NnnV-QL09x	Halogen Free Package
GPCH8512A-NnnV-QL01x	Halogen Free Package

Note1: Code number is assigned for customer.

Note2: Code number (N = A - Z or 0 - 9, nn = 00 - 99); version (V = A - Z).

Note3: Package form number (x = 1 - 9, serial number).

Note4: LQFP44 only bonds 10 IO pads, so IR carrier/External interrupt/RC Feedback function is not supported.

9.2. Package Information

9.2.1. LQFP 128-QL09

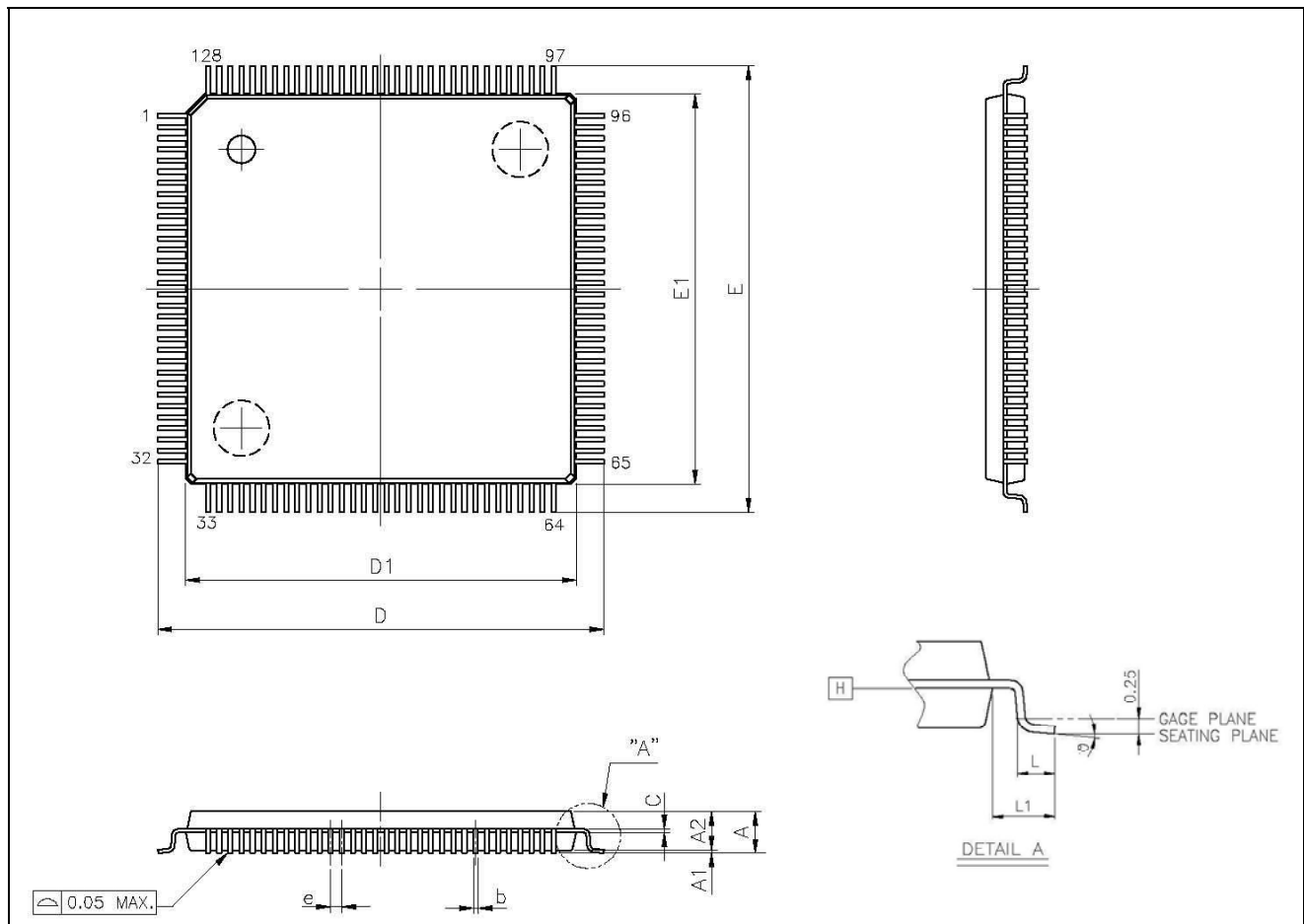

Symbol	Dimension in Millimeter		
	Min.	Typ.	Max.
A	-	-	1.60
A1	0.05	-	0.15
A2	1.35	1.40	1.45
b	0.13	0.16	0.23
c	0.09	-	0.20
D	16.00 BSC.		

Symbol	Dimension in Millimeter		
	Min.	Typ.	Max.
D1	14.00 BSC.		
E	16.00 BSC.		
E1	14.00 BSC.		
e	0.40 BSC.		
L	0.45	0.60	0.75
L1	1.00 REF		
θ	0°	3.5°	7°

9.2.2. LQFP 44-QL01

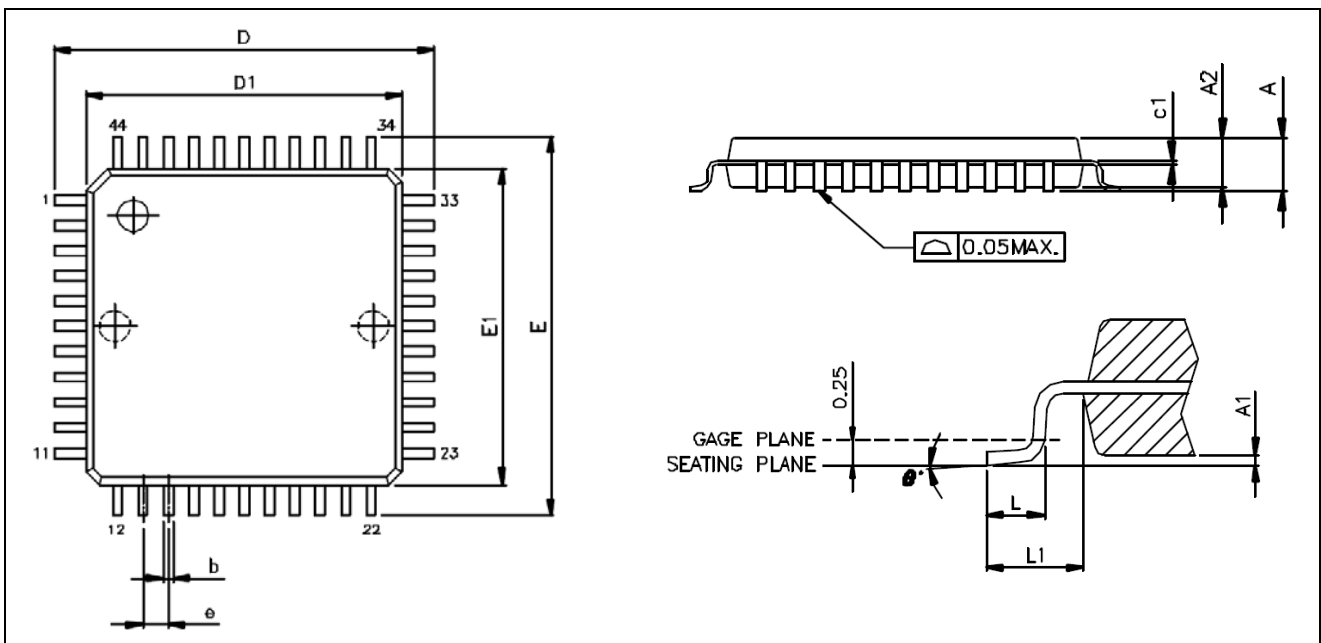

Symbol	Dimension in Millimeter		
	Min.	Nom.	Max.
A	-	-	1.60
A1	0.05	-	0.15
A2	1.35	1.40	1.45
c1	0.09	-	0.16
D	12.00 BSC		
D1	10.00 BSC		
E	12.00 BSC		
E1	10.00 BSC		
e	0.80 BSC		
b	0.30	0.37	0.45
L	0.45	0.60	0.75
L1	1.00 REF		
θ	0°	3.5°	7°

10. DISCLAIMER

The information appearing in this publication is believed to be accurate.

Integrated circuits sold by Generalplus Technology are covered by the warranty and patent indemnification provisions stipulated in the terms of sale only. GENERALPLUS makes no warranty, express, statutory implied or by description regarding the information in this publication or regarding the freedom of the described chip(s) from patent infringement. FURTHERMORE, GENERALPLUS MAKES NO WARRANTY OF MERCHANTABILITY OR FITNESS FOR ANY PURPOSE. GENERALPLUS reserves the right to halt production or alter the specifications and prices at any time without notice. Accordingly, the reader is cautioned to verify that the data sheets and other information in this publication are current before placing orders. Products described herein are intended for use in normal commercial applications. Applications involving unusual environmental or reliability requirements, e.g. military equipment or medical life support equipment, are specifically not recommended without additional processing by GENERALPLUS for such applications. Please note that application circuits illustrated in this document are for reference purposes only.

11. REVISION HISTORY

Date	Revision #	Description	Page
Dec. 09, 2008	1.3	1. Modify 6.3 Low voltage reset	09
		2. Modify 7.4 DAC Characteristics	12
		3. Add 7.5 Regulator Characteristics.	12
		4. Add note in section 8.1 Application circuits.	14
		5. Add note in section 8.2 Application circuits.	15
		6. Modify section 8.3 Current Mode DAC Speaker Driver.	16
Oct. 20, 2008	1.2	1. Modify section 5. SIGNAL DESCRIPTIONS.	5
		2. Modify section 7.2 DC Characteristics (VDD5/VDD5_4 = 3.0V, T _A = 25°C).	12
		3. Modify section 7.3 DC Characteristics (VDD5/VDD5_4 = 5.0V, T _A = 25°C).	12
		4. Modify section 8.1 and 8.2 Application circuits.	15, 16
		5. Delete section 8.3 Generalplus Audio Driver GPY0030A.	17
Apr. 11, 2008	1.1	1. Modify the GENERAL DESCRIPTION in section 1.	3
		2. Modify the Timer/Counter (Timer A/Timer B/Timer C) in section 6.6.	10
		3. Modify the APPLICATION CIRCUITS in section 8.	15-18
Jan. 23, 2008	1.0	Original	22