



GPL081A1

Low Power 160 Dots LCD Controller with 7KB Rom

Aug 03, 2016

Version 1.3

Table of Contents

	<u>PAGE</u>
1. GENERAL DESCRIPTION	3
2. FEATURES	3
3. BLOCK DIAGRAM	3
4. SIGNAL DESCRIPTIONS	4
5. FUNCTIONAL DESCRIPTIONS	5
5.1. ROM AREA	5
5.2. STOP CLOCK MODE	5
5.3. TIMER/COUNTER	5
5.4. LCD CONTROLLER	5
5.5. MAP OF MEMORY AND I/OS	5
6. ELECTRICAL SPECIFICATIONS	6
6.1. ABSOLUTE MAXIMUM RATINGS	6
6.2. DC CHARACTERISTICS	6
6.2.1. Frequency vs. temperature	6
6.2.2. Frequency vs. VDD	6
7. APPLICATION CIRCUIT	7
8. PACKAGE/PAD LOCATIONS	8
8.1. PAD ASSIGNMENT	4
8.2. ORDERING INFORMATION	8
9. DISCLAIMER	9
10. REVISION HISTORY	10

LOW POWER 160 DOTS LCD CONTROLLER WITH 7KB ROM

1. GENERAL DESCRIPTION

GPL081A1, a special designed CMOS 8-bit microprocessor by Generalplus, offers the best cost/performance ratio in the industry. It combines RAM, ROM, I/Os, an interrupt controller, and an automatic display controller/driver in a small package. One of its extraordinary features is the capability of operating in low voltage range, from 1.2V ~ 1.7V. The Power Down Mode keeps LCD being displayed when CPU is in standby mode, but consumes only less than 3.5 μ A. Not only GPL081A1 is capable of displaying LCD, but it also can process complex instructions and functions as well. The development team has designed GPL081A1 to cover many application fields such as calculator, watch and other LCD related products required only one battery supply.

2. FEATURES

- Built-in 8-bit RISC processor
- 128-byte SRAM
- 7.5K-byte ROM
- CPU frequency: 300KHz or 600KHz (mask option)
@ 1.5V (dependent VDD)
- Built-in RC oscillator
- Built-in 32.768KHz oscillator circuit for real clock function
- Watch dog mode (1Hz or 0.5Hz)
- Low operating voltage: 1.2V - 1.7V
- Low standby current, $I_{STBY} < 1\mu A$
- LCD matrix: 28 - 32 segments, 4 (or 5) commons
- 12 general I/O pins (segment 29, 30, 31, 32 can be defined as I/O; ABB1 can be optioned to 5th common)
- LCD 1/2, 1/3 bias, 1/2, 1/3, 1/4, 1/5 (mask option) duty
- One 8-bit timer
- 6 interrupt sources
(Timer, T16Hz, T2Hz, 128Hz, 2KHz, external interrupt)
- Power down mode
(wake-up source: key input, T2Hz, T16Hz, timer)

Note1: T16Hz: 32Hz, 16Hz, 8Hz or 4Hz

Note2: T2Hz: 2Hz or 1Hz

3. BLOCK DIAGRAM

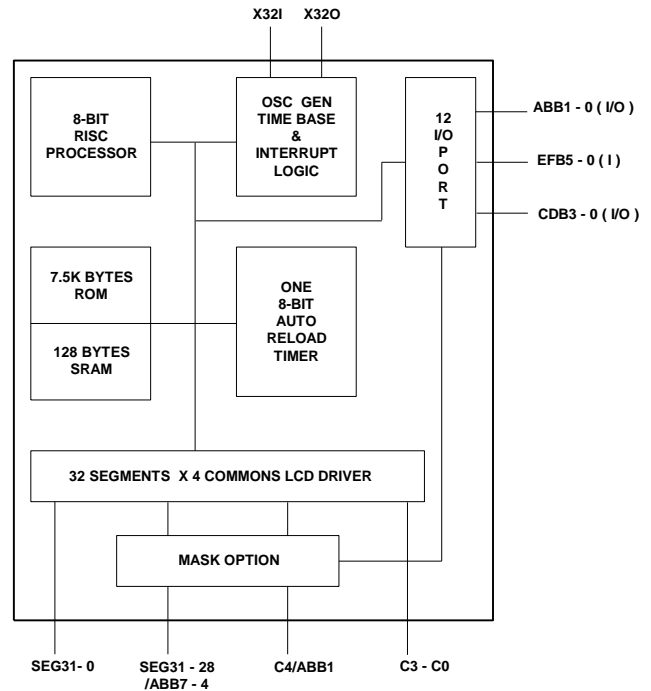

Note1: By mask option, SEG31 - 28 can be defined as either segment output or I/O. (SEG31 - 28 or ABB7 - 4)

Note2: By mask option, ABB1 can be defined as either I/O or common output (ABB1 or common4)

4. SIGNAL DESCRIPTIONS

Mnemonic	PIN No.	Type	Description
SEG26 - 0 SEG31 - 27	30 - 4 36 - 32	O	LCD driver segment output. SEG31 - 28 can be mask option for ABB7 - 4.
C3 - 0	54 - 57	O	LCD driver common output.
ABB1 - 0	37 - 38	I/O	I/O port (ABB1 can be mask option for COM4)
EFB5 - 0	44 - 49	I	Input port (also for key wake up input)
CDB3 - 0	42 - 39	I/O	I/O port is applicable for sensor.
RESET	50	I	System reset input.
X32I	51	I	32.768KHz crystal input (provide LCD frequency)
X32O	52	O	32.768KHz crystal output.
TEST	53	I	Test input.
VDD	43	I	Power input
VSS	31	I	Ground input.
V3 V45	58 1	I	Inputs for setting LCD bias.
CUP1 CUP2	2 3	I	Inputs for setting LCD bias.

4.1. PAD Assignment

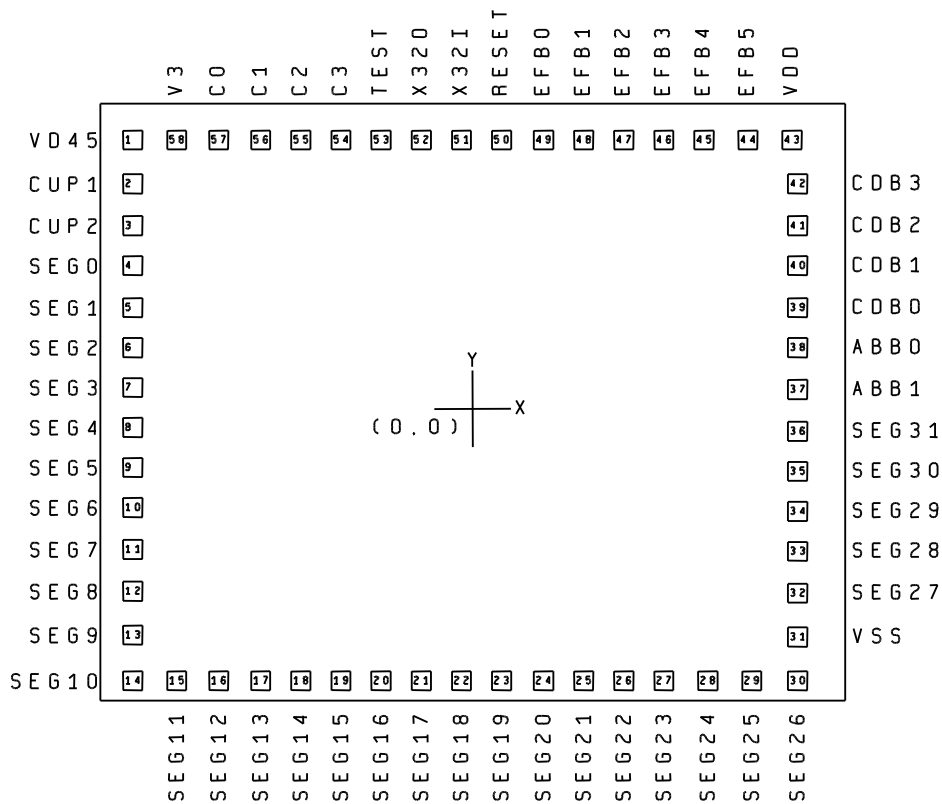

This IC substrate should be connected to VSS or floated

Note1: The 0.1μF capacitor between VDD and VSS should be placed to IC as close as possible.

5. FUNCTIONAL DESCRIPTIONS

5.1. ROM Area

The GPL081A1 provides 7.5K-byte ROM with a LCD driver that is capable of controlling 4 (or 5) commons and 32 segments. (Basically, 7K byte of ROM is available for application program and data, 0.5K bytes is allocated for test program.)

5.2. Stop Clock Mode

The GPL081A1 provides a power saving mode for those applications required very low stand-by current. Users can simply enable wakeup sources to stop the CPU clock by writing the STOP CLOCK Register (\$09). By doing that, CPU will go to standby mode and the RAM and I/Os remain in their previous states until wakeup. There are three wake-up sources in the GPL081A1, Port EFB wake-up, TIMER wake-up and T2Hz or T16Hz wake-up. After GPL081A1 wakes up, CPU will go to the next state of sleep. Wake-up action will not affect RAM and I/Os.

Note1: T16Hz: 32Hz, 16Hz, 8Hz or 4Hz

Note2: T2Hz: 2Hz or 1Hz

5.3. Timer/Counter

The GPL081A1 contains an 8-bit timer. In the timer mode, TMA is a re-loadable up-counter. It will automatically be reloaded with the user's preset value and up-count again.

The clock source is selected as the following:

Timer/Counter	Addr.	Clock Source
TMA	8-BIT TIMER	\$0025 CPU CLOCK (T) or CLK32K (32768Hz or CPU clock / 8)

5.4. LCD Controller

GPL081A1 contains a LCD controller/driver that provides the capability of driving 5 commons and 32 segments LCD. To light the overhead of CPU, a display buffer is designed for mapping to LCD. A LCD dot/pattern is set ON or OFF by programming the corresponding bit of the display buffer. To make the chip more flexible, the pin SEG31, 30, 29, 28, can be selected as I/O pins by mask option. In addition, the LCD bias can be programmed as 1/2 or 1/3. The duty can be selected as 1/2, 1/3, 1/4 or 1/5.

5.5. Map of Memory and I/Os

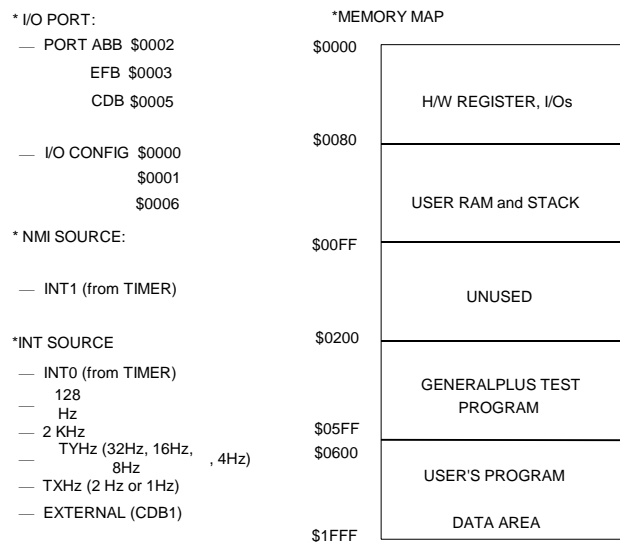

6. ELECTRICAL SPECIFICATIONS

6.1. Absolute Maximum Ratings

Characteristics	Symbol	Ratings
DC Supply Voltage	V_+	< 1.7V
Input Voltage Range	V_{IN}	-0.5V to $V_+ + 0.5V$
Operating Temperature	T_A	0°C to +60°C
Storage Temperature	T_{STO}	-50°C to +150°C

Note: Stresses beyond those given in the Absolute Maximum Rating table may cause permanent damage to the device. For normal operational conditions see AC/DC Electrical Characteristics.

6.2. DC Characteristics

Characteristics	Symbol	Limit			Unit	Test Condition
		Min.	Typ.	Max.		
Operating Voltage	VDD	1.2	-	1.7	V	-
Halt Current 1	I_{HALT1}	-	3.0	-	μA	$F_{CPU} = 0.3MHz @ 1.5V$, no load use 32768Hz crystal
Halt Current 2	I_{HALT2}	-	16	-	μA	$F_{CPU} = 0.3MHz @ 1.5V$, no load no use 32768Hz crystal
Operating Current	I_{OP}	-	35	-	μA	$F_{CPU} = 0.3MHz @ 1.5V$, no load
Standby Current	I_{STBY}	-	-	1.0	μA	VDD = 1.5V, 32768 Hz OFF
OSC Frequency	F_{OSC2}	-15%	0.6	+15%	MHz	VDD = 1.5V
			1.2			
Input High Level	V_{IH}	1.1	-	-	V	VDD = 1.5V
Input Low Level	V_{IL}	-	-	0.5	V	VDD = 1.5V
Output High Current (I/O)	I_{OH}	-	-1.0	-	mA	VDD = 1.5V $V_{OH} = 1.0V$
Output Sink Current (I/O)	I_{OL}	-	2.5	-	mA	VDD = 1.5V $V_{OL} = 0.5V$
CPU Clock	F_{CPU}	-15%	0.3	+15%	MHz	0.3, 0.6MHz by code option $F_{CPU} = F_{OSC}/2 @ 1.5V$
			0.6			

6.2.1. Frequency vs. temperature

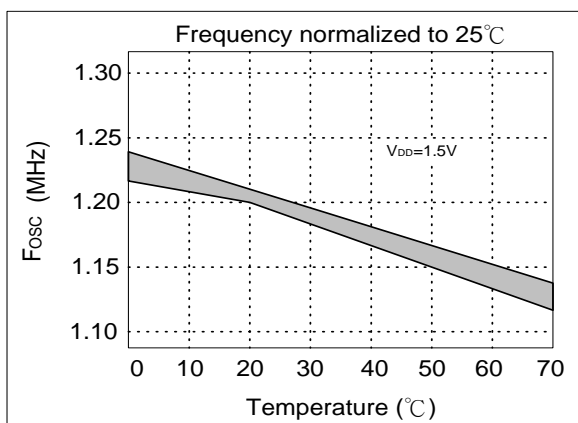

6.2.2. Frequency vs. VDD

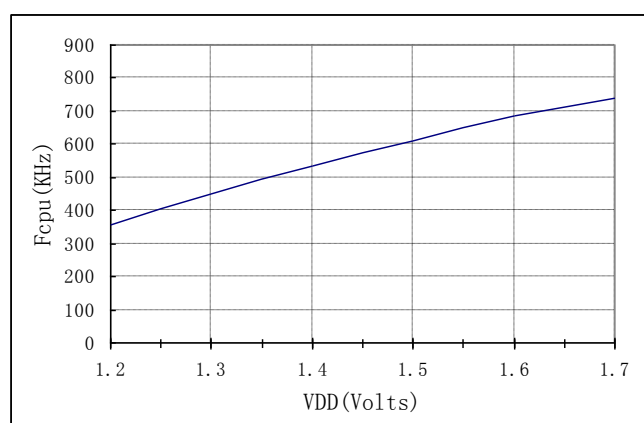

7. APPLICATION CIRCUIT

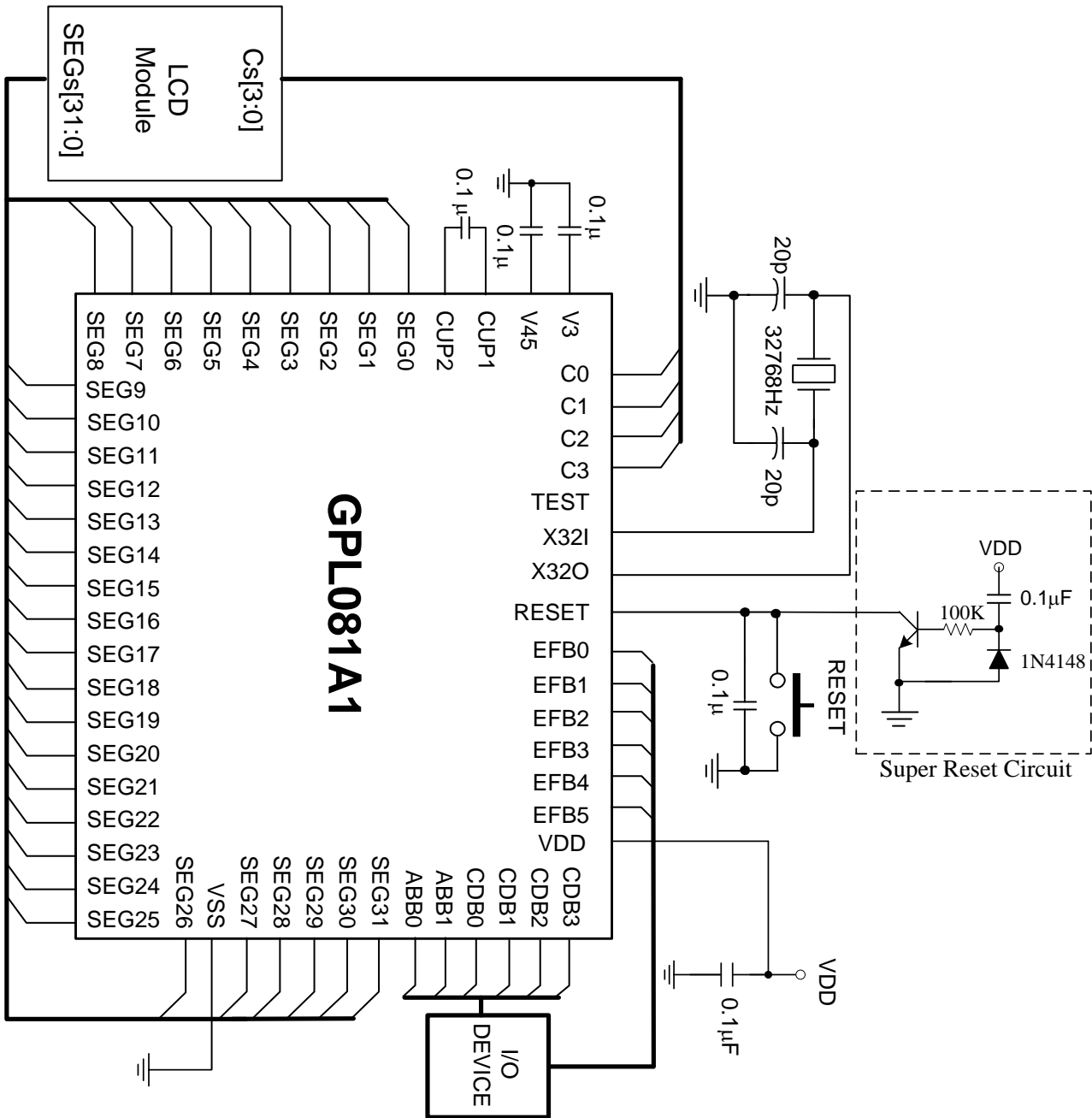

Note: The 0.1µF capacitor between VDD and VSS should be placed to IC as close as possible. (2) Super reset circuit is able to prevent the voltage level from brown out which may further lead CPU run into unstable state.

8. PACKAGE/PAD LOCATIONS

8.1. Ordering Information

Product Number	Package Type
GPL081A1 - NnnV - C	Chip form

Note1: Code number is assigned for customer.

Note2: Code number (N = A - Z or 0 - 9, nn = 00 - 99); version (V = A - Z).

9. DISCLAIMER

The information appearing in this publication is believed to be accurate.

Integrated circuits sold by Generalplus Technology are covered by the warranty and patent indemnification provisions stipulated in the terms of sale only. GENERALPLUS makes no warranty, express, statutory implied or by description regarding the information in this publication or regarding the freedom of the described chip(s) from patent infringement. FURTHERMORE, GENERALPLUS MAKES NO WARRANTY OF MERCHANTABILITY OR FITNESS FOR ANY PURPOSE. GENERALPLUS reserves the right to halt production or alter the specifications and prices at any time without notice. Accordingly, the reader is cautioned to verify that the data sheets and other information in this publication are current before placing orders. Products described herein are intended for use in normal commercial applications. Applications involving unusual environmental or reliability requirements, e.g. military equipment or medical life support equipment, are specifically not recommended without additional processing by GENERALPLUS for such applications. Please note that application circuits illustrated in this document are for reference purposes only.

10. REVISION HISTORY

Date	Revision #	Description	Page
Aug 18, 2016	1.3	Add super reset application circuit in section 7	7
OCT. 24, 2011	1.2	CPUCK frequency modified from "500KHz" to "600KHz".	3, 6
FEB. 20, 2006	1.1	1. Modify the descriptions in section 6.2.	4
		2. Remove the pad locations.	7
MAR. 16, 2005	1.0	Original Note: The GPL081A1 data sheet v1.0 is a continued version of SPL081A1 data sheet v1.1.	9