

DATA SHEET

GPL83110UA

1536-dot Mono LCD Controller / Driver with USB/1M-byte ROM

Jul. 21, 2014

Version 1.3

Generalplus Technology Inc. reserves the right to change this documentation without prior notice. Information provided by Generalplus Technology Inc. is believed to be accurate and reliable. However, Generalplus Technology Inc. makes no warranty for any errors which may appear in this document. Contact Generalplus Technology Inc. to obtain the latest version of device specifications before placing your order. No responsibility is assumed by Generalplus Technology Inc. for any infringement of patent or other rights of third parties which may result from its use. In addition, Generalplus products are not authorized for use as critical components in life support devices/ systems or aviation devices/systems, where a malfunction or failure of the product may reasonably be expected to result in significant injury to the user, without the express written approval of Generalplus.

Table of Contents

PAGE

TABLE OF CONTENTS	2
1. GENERAL DESCRIPTION	3
2. BLOCK DIAGRAM	3
2.1. GPL83110UA	3
3. FEATURES	3
4. APPLICATION FIELD	4
5. SIGNAL DESCRIPTIONS	5
5.1. MAIN FUNCTION PIN	5
6. FUNCTIONAL DESCRIPTIONS	7
6.1. MEMORIES	7
6.2. OPERATING STATES	7
6.2.1. Operating Mode	7
6.2.2. Standby Mode	7
6.2.3. Halt Mode	7
6.3. SPEECH AND MELODY, AND DAC	7
6.4. HARDWARE PWMIO	7
6.5. LCD CONTROLLER/DRIVER	7
6.6. LCD VOLTAGE GENERATOR	7
6.7. USB DEVICE FUNCTION	7
6.8. LOW VOLTAGE DETECTION	7
6.9. WATCHDOG TIMER (WDT)	8
6.10. SPI CONTROLLER	8
7. ELECTRICAL SPECIFICATIONS	9
7.1. ABSOLUTE MAXIMUM RATINGS	9
7.2. DC CHARACTERISTICS (VDD_REGIN=4.5V, FOR 3-BATTERY APPLICATION, INTERNAL REGULATOR ENABLED OUTPUT, T _A =25°C)	9
7.3. DC CHARACTERISTICS(VDD_REGIN= 3.0V, FOR 2-BATTERY APPLICATION, INTERNAL REGULATOR OUTPUT DISABLED, T _A =25°C)	11
7.4. THE RELATIONSHIP BETWEEN THE R _{OSC} AND THE F _{OSC}	12
7.5. THE RELATIONSHIP BETWEEN THE R32K AND THE F32K	12
7.6. THE RELATIONSHIP BETWEEN THE F _{CPU} AND THE I _{OP}	12
7.7. DAC CHARACTERISTICS (VDD_REGIN = 5.0V, T _A = 25°C)	12
7.8. REGULATOR CHARACTERISTICS(TA=25°C)	12
8. APPLICATION CIRCUITS	14
8.1. 1536 DOTS LCD DRIVER, 48 SEGMENTS × 32 COMMONS, FOR 3-BATTERY APPLICATION, INTERNAL 3.3V REGULATOR ENABLED, ROSC24M XTAL32K SELECTED, PB[4:7] CONNECTED TO 3.3V SPI FLASH - (1)	14
8.2. 1536 DOTS LCD DRIVER, 48 SEGMENTS × 32 COMMONS, INTERNAL 3.3V REGULATOR DISABLED, FOR 2-BATTERY APPLICATION, SYSTEM PLL XTAL32K SELECTED - (2)	15
9. ORDERING INFORMATION	16
10. DISCLAIMER	17
11. REVISION HISTORY	18

1536-DOT MONO LCD CONTROLLER / DRIVER WITH USB/1M-BYTE ROM

1. GENERAL DESCRIPTION

The GPL83110UA, an 8-bit microprocessor for LCD handheld products developed by Generalplus, features 1M bytes Mask ROM, 1.5K bytes working RAM, 512 bytes LCD RAM, 22 I/Os, two 16-bit timers, two SPI interfaces, a 14-bit DAC with push-pull amplifier for driving speaker directly, automatic display controller/driver for mono LCD. In display features, it contains up to 48 segments and 32 commons, forming a maximum of 1536 dots LCD resolution. The GPL83110UA is designed to operate over a wide voltage, ranging from 2.3V through 5.5V. In addition, Low Voltage Reset function assures system keep operating properly when power drops below certain level. The GPL83110UA is incorporated a high performance SPU engine to implement 8-channel ADPCM/PCM high quality voice. Moreover, it has one 14-bit DAC with push-pull amplifier for driving speaker directly. Its large memory area allows user to store both program and audio data in one place. The USB device function assures data transmitted in an ultra-high speed and reliability. A Serial Peripheral Interface (SPI) controller is also built in GPL83110UA to facilitate communication between devices. For more information about GPL83110UA's feature list, please refer to the following section.

2. BLOCK DIAGRAM

2.1. GPL83110UA

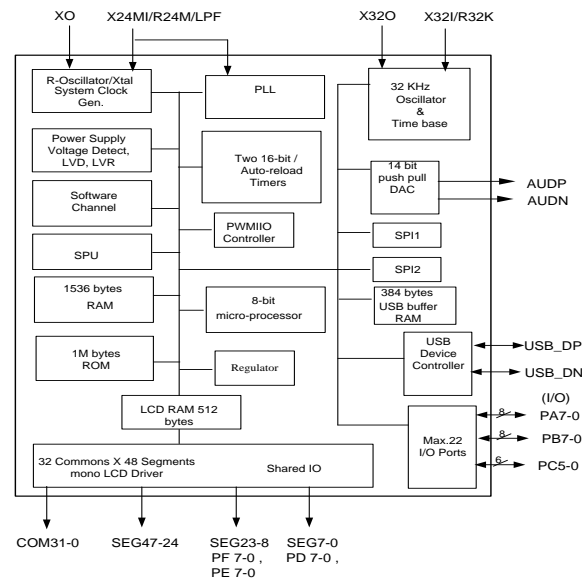

3. FEATURES

- 8-bit microprocessor
- 1M bytes Mask ROM
- 1.5K bytes SRAM
- 512 bytes LCD RAM
- Operating voltage: 2.3V – 5.5V
- Max. CPU operating speed:
 - 12.0MHz @ 2.7V – 5.5V
 - 8.0MHz @ 2.3V – 3.6V
- Programmable CPU clock: /2, /4, /8, /16, /32, /64 and /128 clock frequency
- Six wake-up sources
- 23 IRQs & 4 NMI Interrupts
- Internal built-in regulator to supply core power (3.3V, for 3-battery application). Also internal built-in regulator can be turned off and external power is used to supply core power (for 2-battery application).
- Supports USB 2.0 full speed (12MHz) compliant device with built-in transceiver
- SPU(Sound Processing Unit) engine with 8 voice channels
 - Supports 4/5 bit ADPCM and 8/16 bit PCM data format
 - Transforms 4/5 bit ADPCM data to 14 bit data to play high quality sound

- Supports special tag such as Silence Tag, Event tag
- One software channel with noise filter to play high quality sound.
- Programmable LCD driver
 - Up to 48 segments and 32 commons, forming a maximum of 1536 dots LCD resolution; User can select different segment/common combination including 16 x 64, 24 x 56 and 32 x 48 etc.
 - Supports from 1/2 duty up to 1/32 duty
 - Supports 1/3, 1/4, 1/5, 1/6, 1/6.5, 1/7 bias
 - 512 bytes dedicated LCD RAM
 - Supports normal type-B and type-C LCD waveform with or without key scan
 - Built-in voltage regulator to generate VLCD for LCD driver
 - 46-level contrast control (VLCD=3.5V ~ 8V)
 - Power saving SLEEP mode
- Low Voltage Detector
 - 8-level (2.3V/ 2.4V/ 2.6V/ 2.9V/ 3.0V/ 3.3V/ 3.6V/ 4.0V) voltage detector
- Low Voltage Reset
- Peripherals
 - Dedicated I/Os: PA[7:0], PB[7:0], PC[5:0]
 - Shared I/Os: PD[7:0]/SEG[7:0], PE[7:0]/SEG[15:8], PF[7:0]/SEG[23:16]
 - Eight I/Os with high sink current for LED application
 - Key wakeup/interrupt function
- Built-in 32.768KHz oscillator circuit for real time clock function (X'tal or R-osc)
- Built-in R-oscillator (external resistor is needed) or X'tal or PLL for system operating clock
- Internal time base generator
- Two 16-bit reloadable timer/counters
- Watchdog timer
- 14-bit DAC with push-pull amplifier for driving speaker directly
- IR output
- Hardware PWMIO
- Two SPI serial interface I/Os
- Powerful 8-ch Sound Processing Unit (SPU)
 - Variable tone-color sampling rate: max = 96KHz @ SPU_clock = 24MHz
 - 8-voice polyphony
 - Supports PCM/ADPCM tone-color table

4. APPLICATION FIELD

- Handheld LCD game
- Educational toys (Electronic Learning Aids)
- Data bank
- Dictionary
- Translator

5. SIGNAL DESCRIPTIONS

5.1. Main Function PIN

Mnemonic	PIN No.	Type	Description
SEG7-0/PD7-0	60-53	O	LCD driver segment output. SEG7-0 shared pin with PD7-0
SEG15 - 8 /PE7-0	45-52	O	LCD driver segment output. SEG15 - 8 shared pin with PE7-0
SEG23 - 16/PF7-0	37-44	O	LCD driver segment output. SEG23 - 16 shared pin with PF7-0
SEG47 - 24	12-30,32-36	O	LCD driver segment output.
COM24- 31/ SEG55-48	4-11	O	COM24-31 in 32x48; SEG55-48 in 24x56 and 16x64
COM16- 23 / SEG63 - 56	149-153,1-3	O	COM16-23 in 24x56 and 32x48; SEG63 – 56 in 16x64
COM15 - 0	76-61	O	LCD driver common output.
PA0/IRO/EXT1	95	I/O	PA0 is a bi-directional I/O port, which can be software programmed as wakeup I/O and is shared with IRO (IR output) and external interrupt 1.
PA1/EXT2	94	I/O	PA1 is a bi-directional I/O port, which can be software programmed as wakeup I/O and is shared with external interrupt 2.
PA3 - 2	92,93	I/O	PA3-2 is a bi-directional I/O port, which can be software programmed as wakeup I/O.
PA4/ PWMIO0	91	I/O	PA4 is a bi-directional I/O port, which can be software programmed as wakeup I/O and is shared with PWMIO0.
PA5/ PWMIO1	90	I/O	PA5 is a bi-directional I/O port, which can be software programmed as wakeup I/O and is shared with PWMIO1.
PA6/ PWMIO2	89	I/O	PA6 is a bi-directional I/O port, which can be software programmed as wake up I/O and is shared with PWMIO2.
PA7/PWMIO3	88	I/O	PA7 is a bi-directional I/O port, which can be software programmed as wakeup I/O and is shared with PWMIO3.
PB0/SPI2_CSN/IISCKO	86	I/O	PB0 is shared with SPI2_CSN and IISCKO
PB1/ SPI2_SCK/IISDAO	85	I/O	PB1 is shared with SPI2_SCK and IISDAO
PB2/ SPI2_SDO/IISWSO	84	I/O	PB2 is shared with SPI2_SDO and IISWSO
PB3/ SPI2_SDI	83	I/O	PB3 is shared with SPI2_SDI.
PB4/SPI1_CSN/ PWMIO0	81	I/O	PB4 is shared with SPI1_CSN and shared with PWMIO0 and is a high drive IO.
PB5/SPI1_SCK/ PWMIO1/IISCKI	80	I/O	PB5 is shared with SPI1_SCK and IISCKI and shared with PWMIO1 and is a high drive IO.
PB6/SPI1_SDO/ PWMIO2/IISDAI	79	I/O	PB[6:5] is shared with SPI1_SDO and IISDAI and shared with PWMIO2 and is a high drive IO.
PB7/ SPI1_SDI/ PWMIO3/IISWSI	78	I/O	PB7 is shared with SPI1_SDI and IISWSI and shared with PWMIO3 and is a high drive IO.
PC5 -0	96-101	I/O	PC[5:0] is a bi-directional I/O port
R24MI/LPF	104	I	ROSC input connected to VDD33V_REGOUT through a resistor, or RC low pass filter connection for PLL(Mask option).
RESETB	110	I	System reset input, low active, internal pull high.
AUDP, AUDN	115,113	O	Audio output of push pull DAC
NC	119	I	Unused pin for user
X32I/R32K	105	I	32.768KHz crystal input or connects to VDD33V_REGOUT through a resistor (option).
X32O	106	O	32.768KHz crystal output
TEST	111	I	Test input, internal pull low

Mnemonic	PIN No.	Type	Description
CAP1P, CAP1N	122,123	P	LCD voltage generation. Charge pump capacitor interconnection pins.
CAP2P, CAP2N	124,125	P	LCD voltage generation. Charge pump capacitor interconnection pins.
LCDVPP	126	P	LCD voltage generation. Voltage generated by charge pump.
V4	128	P	LCD voltage generation
V3	129	P	LCD voltage generation
V2	130	P	LCD voltage generation
V1	131	P	LCD voltage generation
VLCD	127	P	LCD voltage generation. The highest Voltage for LCD display.
VDD_REGIN	109	P	Power for Regulator
VSS_REG	108	P	Ground for Regulator
VDD33V_REGOUT	107	P	3.3V power output from regulator (regulator can be off when external 3V is supplied).
VDD_LCD	120	P	Power for LCD driver
VSS_LCD	121	P	Ground for LCD driver
VDD_IO	87	P	Power for PA, PC, PD, PE, PF
VSS_IO	82	P	Ground for PA, PB, PC, PD, PE, PF
VDD_PB	77	P	Power for PB
VDD_DAC	114	P	Power for push pull DAC driver
VSS_DAC	116	P	Ground for push pull DAC driver
AVDD_DAC	118	P	Analog ground for push pull DAC
AVSS_DAC	117	P	Analog power for push pull DAC
USB_DP	103	I/O	USB_DP pin of USBPHY
USB_DM	102	I/O	USB_DN pin of USBPHY

6. FUNCTIONAL DESCRIPTIONS

6.1. Memories

GPL83110UA contains 1536 bytes SRAM, 512 bytes LCD RAM and 1M bytes ROM.

6.2. Operating States

There are three operation modes in GPL83110UA: standby, halt and operating. The following table shows the differences among these modes.

	Operating	Halt	Standby
CPU	ON	OFF	OFF
32768Hz Oscillator	ON	ON	OFF
LCD Driver	ON	ON/OFF	OFF

6.2.1. Operating Mode

In operating state, all functions (CPU, 32768Hz oscillator, timer/counter, LCD driver...) are activated.

6.2.2. Standby Mode

Turn off 32768Hz oscillator and write "07H" to P_CLK_CPU_Ctrl Register (\$3006) to activate standby mode. The standby mode is a mode that the device is placed in its lowest current consumption state. In standby mode, all functions are turned off; in addition, RAM and I/Os will remain in their previous states.

6.2.3. Halt Mode

Write "07H" to P_CLK_CPU_Ctrl Register (\$3006) but still keeps 32768Hz oscillator running to enter halt mode. In halt mode, CPU clock halts and waits for an event (e.g. key press, timer overflow) to wake up. The 32768Hz related functions, such as timer/counter and LCD driver, may remain active in the halt mode.

The following figure is the GPL83110UA state diagram:

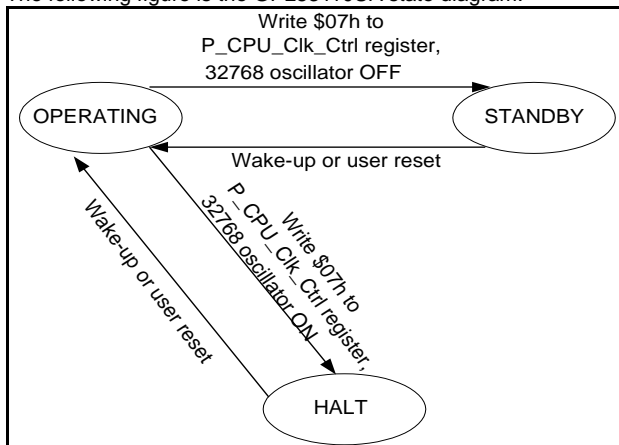

GPL83110UA State Diagram

6.3. Speech and Melody, and DAC

The GPL83110UA uses a high performance SPU voice engine to archive 8-channel voice with ADPCM/PCM code. The SPU also supports automatic zero-crossing concatenating function. A hardware multiplier is also embedded in this SPU for software use. The fixed addresses of RAM area \$0000 - \$009F is designed as address pointers and a data buffer for the 8-channel speech/melody generation. Moreover, one 14-bit software channel with noise filter is also supported. There is one 14-bit DAC with push-pull amplifier for direct audio output.

6.4. Hardware PWMIO

Hardware PWMIO supports 4 LED outputs with brightness control of 256 levels. The clock source of PWMIO can be selected by user's request.

6.5. LCD Controller/Driver

GPL83110UA has a built-in LCD driver and supports monochrome LCD control. The LCD driver can support up to 32COM * 48SEG. Programmers are able to define the LCD configuration by setting up the LCD Control Register. Once the LCD configuration is completed, the desired pattern can be displayed by filling the LCD buffer with proper data. The LCD driver can also operate in halt mode by keeping 32768Hz oscillator running. The LCD driver in GPL83110UA supports 1/2 – 1/32 duty and 1/3 - 1/7 bias.

6.6. LCD Voltage Generator

To achieve highly integrated circuit and save external components, GPL83110UA has built-in charge-pump circuit to generate LCD's bias voltages VLCD, V4, V3, V2 and V1. The level of VLCD can be adjusted by software. We suggest that VLCD must be higher than VDD_IO or abnormal operation will occur.

6.7. USB Device Function

The GPL83110UA provides the device function which is compatible with USB 2.0 full-speed standard. An USB transceiver is also built-in.

6.8. Low Voltage Detection

The GPL83110UA equips an 8-level (Software programmable) low voltage detector to detect low voltage events. Users can turn on the low voltage detection that monitors VDD_REGIN periodically to check whether it is lower than the given value. In addition, if LV NMI is enabled, an NMI will be issued to notify CPU if power voltage drops below the given value. Also, the voltage detector will generate a system reset if power supply voltage drops too low.

6.9. Watchdog Timer (WDT)

An on-chip watchdog timer is also available in the GPL83110UA. The WDT is designed to recover the system from unexpected operations. In some cases, if WDT is not cleared within one second, the WDT will generate a system reset to restart system. If WDT is enabled, it should be cleared periodically to avoid accidental reset. The WDT can be cleared through software programming. Note that the WDT only works when 32768Hz clock is activated.

6.10. SPI Controller

Two Serial Peripheral Interface (SPI) controllers are built-in to enable synchronous serial communication with master/slave peripherals. There are four control signals on SPI including SPICSN, SPICLK (SCK), SPIRX (SDI), and SPITX (SDO). The four signals of SPI1 are shared with PB4, PB5, PB6 and PB7. The four signals of SPI2 are shared with PB0, PB1, PB2 and PB3. While SPI module is enabled by corresponding control bit, these four pins cannot be used as GPIOs and any setting on corresponding GPIO control register will have no effect. Four types of operating modes are supported as follows:

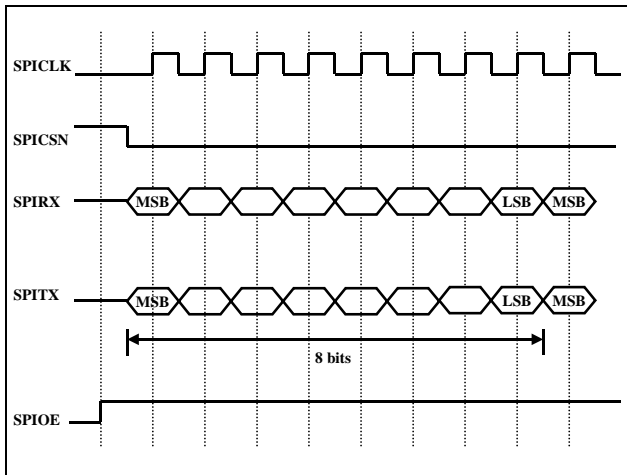

Master Mode, Polarity = 0, Phase=0

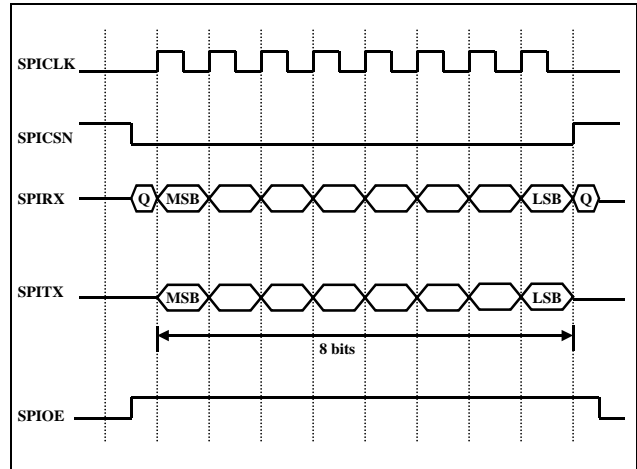

Master Mode, Polarity = 0, Phase=1

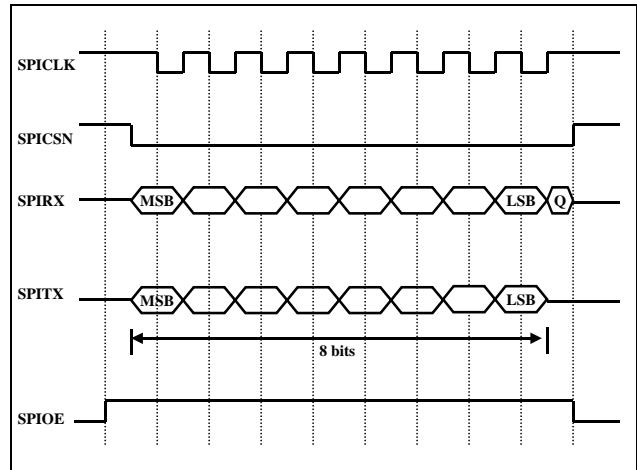

Master Mode, Polarity = 1, Phase=0

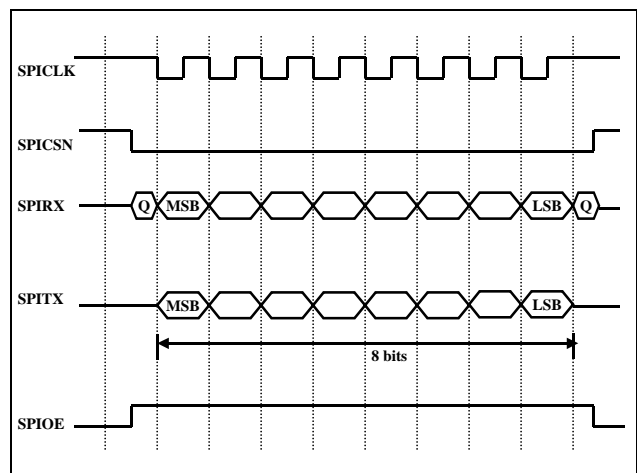

Master Mode, Polarity = 1, Phase=1

7. ELECTRICAL SPECIFICATIONS

7.1. Absolute Maximum Ratings

Characteristics	Symbol	Ratings
DC Supply Voltage	V_+	< 7.0V
Input Voltage Range	V_{IN}	-0.5V to $V_+ + 0.5V$
Operating Temperature	T_A	0°C to +70°C
Storage Temperature	T_{STO}	-50°C to +150°C

Note: Stresses beyond those given in the Absolute Maximum Rating table may cause permanent damage to the device. For normal operational conditions see AC/DC Electrical Characteristics.

7.2. DC Characteristics (VDD_REGIN=4.5V, for 3-battery Application, Internal Regulator Enabled Output, $T_A=25^\circ\text{C}$)

Characteristics	Symbol	Limit			Unit	Test Condition
		Min.	Typ.	Max.		
Operating Voltage	VDD_REGIN	2.7	-	5.5	V	For 3-battery
Operating Current	I_{OP1}	-	6	9	mA	$F_{CPU} = 8.0\text{MHz}$ @ 5.0V $F_{XTAL} = 16.0\text{MHz}$, no load, DAC disabled. PLL2 OFF/USB OFF
	I_{OP2}	-	8	12	mA	$F_{CPU} = 12.0\text{MHz}$ @ 5.0V $F_{ROSC} = 24.0\text{MHz}$, no load, DAC disabled. PLL2 OFF/USB OFF
Halt Current	I_{HALT}	-	55	110	μA	VDD_REGIN = 4.5V, 32K X'tal ON, Strobe off, LCD ON, 1/7 Bias, VLCD=TBD V, no LCD panel
Standby Current(Regulator on)	I_{STBYR}	-	5	10	μA	VDD_REGIN = 4.5V, internal regulator on, all off.
Input High Level	V_{IH}	0.7VDD_IO	-	VDD_IO	V	VDD_IO = 4.5V
Input Low Level(PA/PB/PC) (PD/PE/PF)	V_{IL1}	0	-	0.3VDD_IO	V	VDD_IO = 4.5V
	V_{IL2}					
Output High Current (I/O) PA/PB4~PB7 PB0~PB3/PC PD/PE/PF	I_{OH1}	9.8	14	18.2	mA	VDD_IO = 4.5V, $V_{OH} = 3.15V$
	I_{OH2}	7	10	13		
	I_{OH3}	3.5	5	6.5		
Output Sink Current (I/O) PA4~PA7 PB4~PB7 PA0~PA3/PB0~PB3/PC PD/PE/PF	I_{OL1}	25	50	75	mA	VDD_IO = 4.5V, $V_{OL} = 1.35V$
	I_{OL2}	18	36	54		
	I_{OL3}	6.3	9	11.7		
	I_{OL4}	3.5	5	6.5		
Input Pull-Low Resistor PA(weak pull) PA(strong pull) PB~PF	R_{PL}	100	150	200	$K\Omega$	$V_{IN} = 4.5V$
		35	50	65		
		35	50	65		
Input Pull-High Resistor PA(weak pull) PA(strong pull) PB,PC	R_{PH}	100	150	200	$K\Omega$	$V_{IN} = 0V$
		35	50	65		
		35	50	65		

Characteristics	Symbol	Limit			Unit	Test Condition
		Min.	Typ.	Max.		
LCD Driver Voltage ($V_{LCD} - VSS$)	V_{LCD}	3.5	-	8	V	$VDD_REGIN = 4.5V$, no load
OSC Resistor	R_{OSC}	-	23	-	K Ω	$F_{OSC} = 24MHz @ 4.5V$
OSC32K Resistor	R_{OSC32k}	-	3.1	-	M Ω	$F_{OSC32} = 32768Hz @ 4.5V$
CPU Clock	F_{CPU}	-	-	12	MHz	$F_{CPU} = F_{OSC}/2 @ 2.7V$

Note: V_{LCD} should be higher than VDD_IO to prevent abnormal functions.

7.3. DC Characteristics(VDD_REGIN= 3.0V, for 2-battery Application, Internal Regulator Output Disabled, T_A=25°C)

Characteristics	Symbol	Limit			Unit	Test Condition
		Min.	Typ.	Max.		
Operating Voltage	VDD_REGIN	2.3	-	3.6	V	For 2-battery
Operating Current	I _{OP1}	-	5	8	mA	F _{CPU} = 8.0MHz @ 3.0V F _{X TAL} = 16.0MHz, without loading, DAC disabled. PLL2 OFF/USB OFF
	I _{OP2}	-	7	10	mA	F _{CPU} = 12.0MHz @ 3.0V F _{ROSC} = 24.0MHz, no load, DAC disabled. PLL2 OFF/USB OFF
Halt Current	I _{HALT}	-	50	100	μA	VDD_REGIN = 3.3V, 32K X'tal ON, Strobe off, LCD ON, 1/7 Bias, VLCD=TBD V, no LCD panel
Standby Current(Regulator off)	I _{STBY}	-	1	5	μA	VDD_REGIN = 3.0V, all off
Input High Level(PA/PB/PC) (PD/PE/PF)	V _{IH1} V _{IH2}	0.7VDD_IO	-	VDD_IO	V	VDD_IO = 3.0V
Input Low Level(PA/PB/PC) (PD/PE/PF)	V _{IL1} V _{IL2}	0	-	0.3VDD_IO	V	VDD_IO = 3.0V
Output High Current (I/O) PA/PB4~PB7 PB0~PB3/PC PD/PE/PF	I _{OH1} I _{OH2} I _{OH3}	4.9 3.5 1.75	7 5 2.5	9.1 6.5 3.25	mA	VDD_IO = 3.0V, V _{OH} = 2.1V
Output Sink Current (I/O) PA4~PA7 PB4~PB7 PA0~PA3/PB0~PB3/PC PD/PE/PF	I _{OL1} I _{OL2} I _{OL3} I _{OL4}	13 10 3.5 2.1	26 20 5 3	39 30 6.5 3.9	mA	VDD_IO = 3.0V, V _{OL} = 0.9V
Input Pull-Low Resistor PA(weak pull) PA(strong pull) PB~PF	R _{PL}	100 35 35	150 50 50	200 65 65	KΩ	V _{IN} = 3.0V
Input Pull-High Resistor PA(weak pull) PA(strong pull) PB,PC	R _{PH}	100 35 35	150 50 50	200 65 65	KΩ	V _{IN} = 0V
LCD Driver Voltage (V _{LCD} - VSS)	V _{LCD}	3.5	-	8	V	VDD_IO = 3.0V
OSC Resistor	R _{OSC}	-	34	-	KΩ	F _{OSC} = 16MHz @ 3.0V
OSC32K Resistor	R _{OSC32k}	-	3.1	-	MΩ	F _{OSC32} = 32768Hz @ 3.0V
CPU Clock	F _{CPU}	-	-	8	MHZ	F _{CPU} = F _{OSC} /2 @ 2.3V

Note: V_{LCD} should be higher than VDD to prevent abnormal functions.

7.4. The Relationship between the R_{OSC} and the F_{OSC}

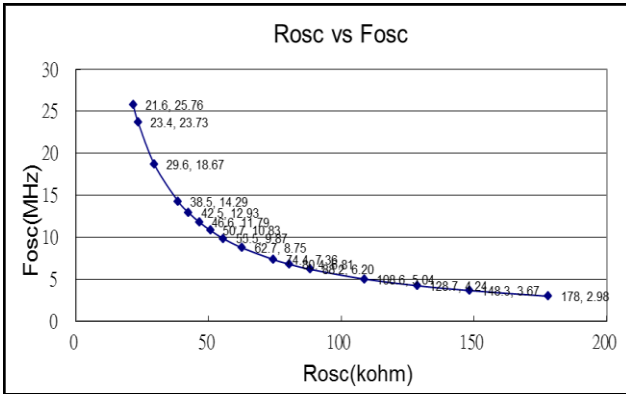

7.6. The Relationship between the F_{CPU} and the I_{OP}

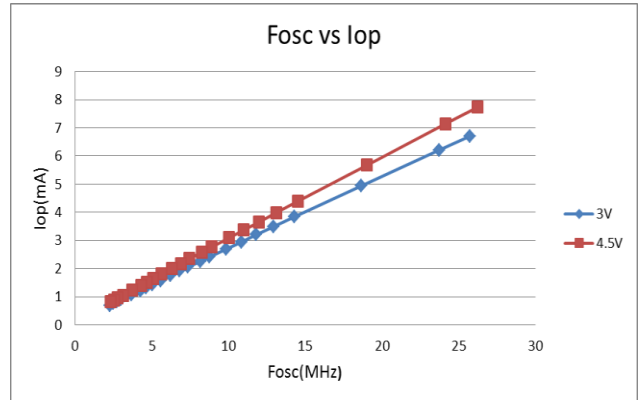

7.5. The Relationship between the R_{32K} and the F_{32K}

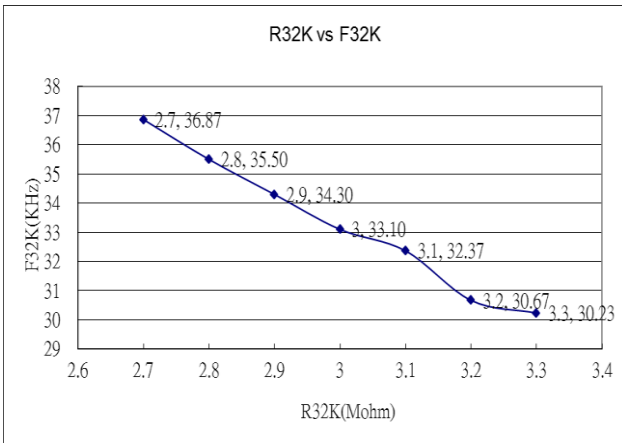

7.7. DAC Characteristics (VDD_REGIN = 5.0V, TA = 25°C)

Characteristics	Symbol	Limit			Unit
		Min.	Typ.	Max.	
DAC Resolution	RESO	-	-	14	bit
THD+n (5V@0.45W)	-	-	0.1	-	%
Noise at No Signal	-	-	-65	-	dBr A
Dynamic Range(-60dB)	-	-	-65	-	dBr A

7.8. Regulator characteristics(TA=25°C)

Characteristics	Symbol	Limit			Unit	Test Condition
		Min.	Typ.	Max.		
Input Voltage	VREGI	2.3	-	5.5	V	
Maximum Current Output	IREGO ₄₅	-	-	60	mA	VDD5V (Regulator in) = 4.5V, ΔVDD (Regulator out) <100mV
Maximum Current Output	IREGO ₃₀	-	-	60	mA	VDD5V (Regulator in) = 3.0V, ΔVDD (Regulator out) <300mV
Output Voltage	VREGO	3.135	3.3	3.465	V	VREGI > 3.5V
Standby Current	IRGES	-	2.5	-	uA	No load

Regulator driving current 30mA:

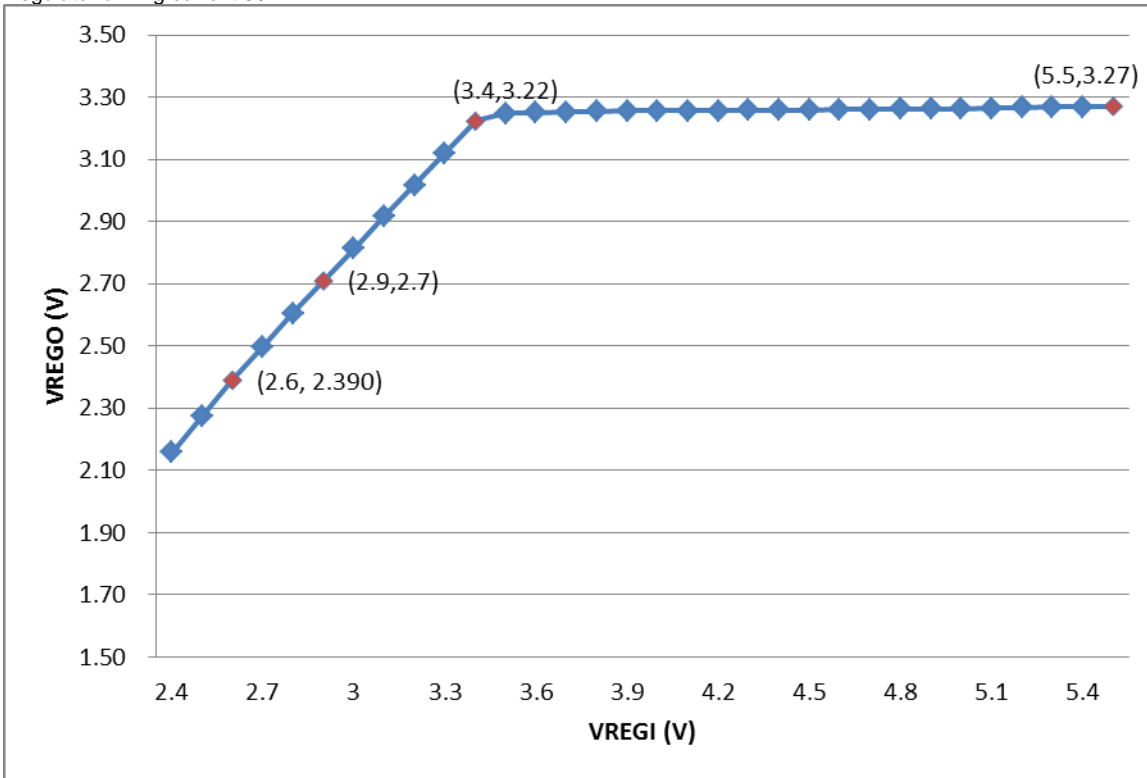

Regulator driving current 60mA:

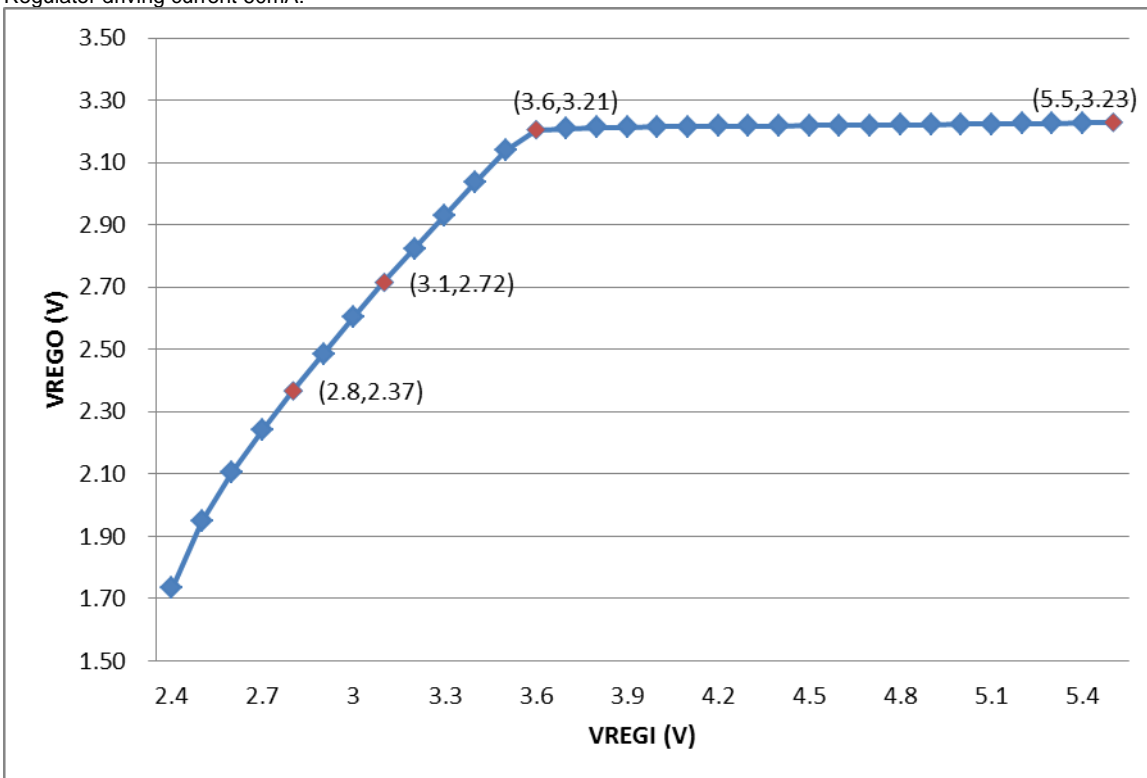

8. APPLICATION CIRCUITS

8.1. 1536 Dots LCD Driver, 48 Segments × 32 Commons, 3-battery, Internal 3.3V Regulator Enabled, ROOSC24M XTAL32K Selected, PB[4:7] Connected to 3.3V SPI Flash using Internal 3.3V Regulator Power - (1)

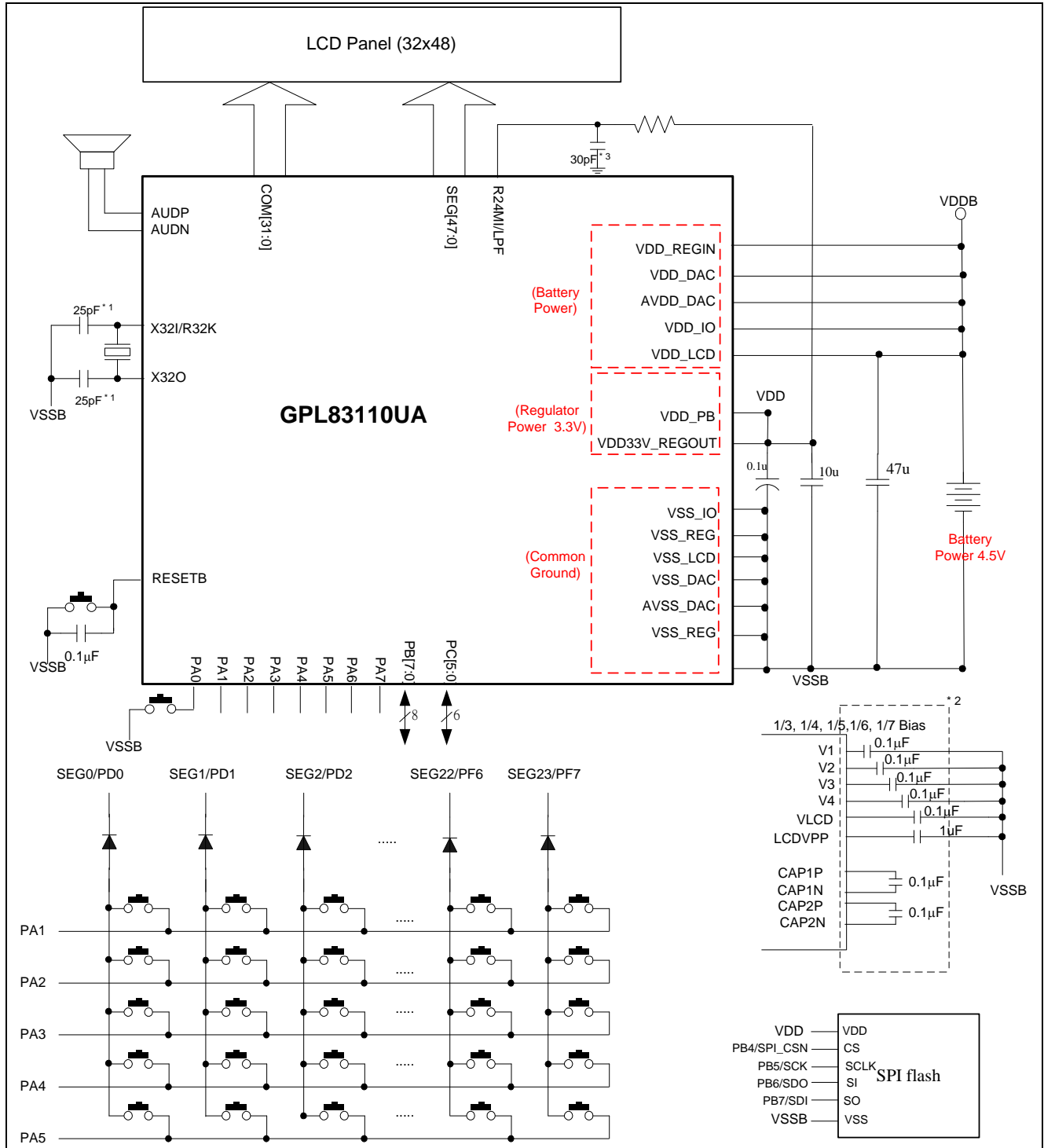

Note*1: These capacitor values are for design guidance only. The recommended 32K XTAL features are ESR=11.2~60K and CL1=CL2 =26~36pF (including PCB parasitic loading, for example, user should apply additional 20~30pF on X32I and X32O if PCB parasitic loading is 6pF).

Note*2: These capacitor values are for design guidance only. The ratio of capacitance of VLCDVPP to the capacitance of CAP1N/CAP1P/CAP2N/CAP2P is recommended to be 10:1. Generally, capacitance of VLCD and V1~V4 is 0.1µF and cannot be larger than capacitance of LCDVPP. But for larger LCD panel, the followings are recommended, 1µF capacitance for VLCD and V1~V4, 2.2µF capacitance for LCDVPP and 0.22µF capacitance for CAP1P/ CAP1N/ CAP2P/ CAP2N.

Note*3: This capacitor can be removed if this node is immune from noise.



GPL83110UA

9. ORDERING INFORMATION

Product Number	Package Type
GPL83110UA -NnnV-C	Chip form

Note1: Code number (NnnV) is assigned for customer.

Note2: Code number (N = A-Z or 0-9, nn=00-99); version (V = A - Z)

10. DISCLAIMER

The information appearing in this publication is believed to be accurate.

Integrated circuits sold by Generalplus Technology are covered by the warranty and patent indemnification provisions stipulated in the terms of sale only. GENERALPLUS makes no warranty, express, statutory implied or by description regarding the information in this publication or regarding the freedom of the described chip(s) from patent infringement. FURTHERMORE, GENERALPLUS MAKES NO WARRANTY OF MERCHANTABILITY OR FITNESS FOR ANY PURPOSE. GENERALPLUS reserves the right to halt production or alter the specifications and prices at any time without notice. Accordingly, the reader is cautioned to verify that the data sheets and other information in this publication are current before placing orders. Products described herein are intended for use in normal commercial applications. Applications involving unusual environmental or reliability requirements, e.g. military equipment or medical life support equipment, are specifically not recommended without additional processing by GENERALPLUS for such applications. Please note that application circuits illustrated in this document are for reference purposes only.

11. REVISION HISTORY

Date	Revision	Description	Page
Jul. 21, 2016	1.3	update IOH/IOL range	9-11
Jul. 30, 2014	1.2	update DC and regulator characteristic and its application circuit.	9-12
Aug 09, 2013	1.1	update VDD_IO/VSS_IO description, update application circuit for 32K xtal.	6,14-15
Nov 07, 2012	1.0	Release to 1.0	4,9-14
Aug 21, 2012	0.2	1. Modify some items of section 5.1 SIGNAL DESCRIPTIONS. 2. Add section 7 and section 8.	5-6 9-13
May 15, 2012	0.1	Original	10