



GPR26L320A

32M-BIT Low Voltage, Serial Mask ROM

Memory with 50MHz SPI Bus Interface

AUG. 13, 2009

Version 1.4

Table of Contents

	<u>PAGE</u>
1. DESCRIPTION	3
2. FEATURES	3
3. MEMORY ORGANIZATION	3
4. BLOCK DIAGRAM	3
5. PIN DESCRIPTION	4
5.1. PAD ASSIGNMENT	4
6. SIGNAL DESCRIPTION	5
6.1. SERIAL DATA OUTPUT (Q)	5
6.2. SERIAL DATA INPUT (D)	5
6.3. SERIAL CLOCK (C).....	5
6.4. CHIP SELECT (SB).....	5
6.5. HOLD (HOLDB).....	5
7. SPI MODES	6
8. OPERATING FEATURES	7
8.1. ACTIVE POWER, STAND-BY POWER	7
8.2. PROTECTION MODES	7
8.3. HOLD CONDITION.....	7
9. INSTRUCTIONS	8
9.1. READ DATA BYTES (READ)	8
9.2. READ DATA BYTES AT HIGHER SPEED (FAST_READ)	9
10. POWER-UP AND POWER-DOWN	10
11. MAXIMUM RATING	11
12. DC AND AC PARAMETERS	11
13. PACKAGE/PAD INFORMATION	14
13.1. ORDERING INFORMATION	14
14. DISCLAIMER	15
15. REVISION HISTORY	16

32M-BIT Low Voltage, Serial Mask ROM Memory with 50MHz SPI Bus Interface

1. DESCRIPTION

The GPR26L320A is a 32Mbit (4M x 8) Serial Mask ROM accessed by a high speed SPI-compatible bus.

3. MEMORY ORGANIZATION

The memory is organized as: - 4M bytes (8 bits each)

2. FEATURES

- 32Mbit of Mask ROM
- 2.7 to 3.6V Single Supply Voltage
- SPI Bus Compatible Serial Interface
- 50MHz Clock Rate (maximum)

4. BLOCK DIAGRAM

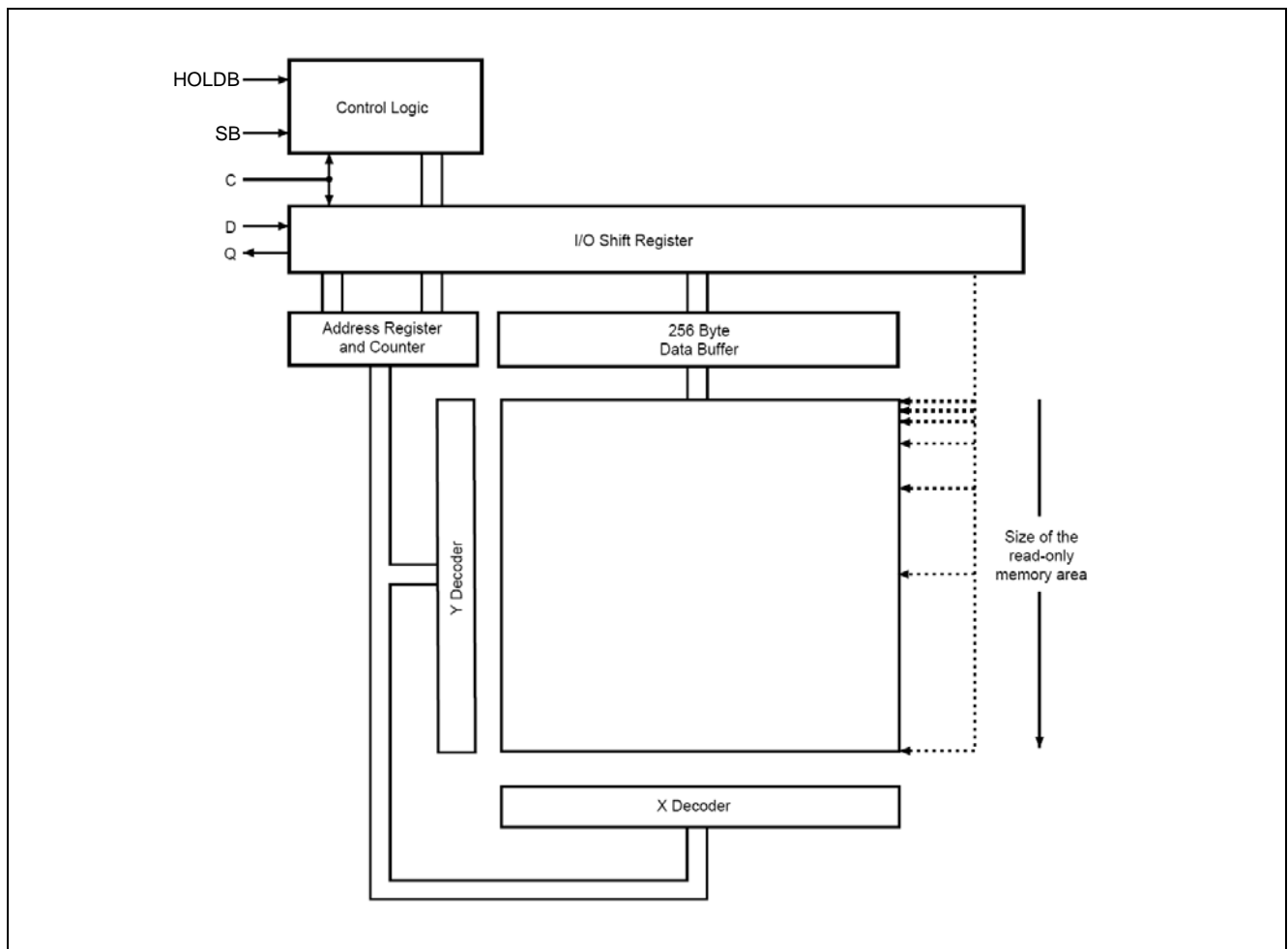

5. PIN DESCRIPTION

Symbol	Description
C	Serial Clock
D	Serial Data Input
Q	Serial Data Output
SB	Chip Select
HOLDB	Hold
VCC1, VCC2	Supply Voltage
VSS1, VSS2	Ground

5.1. PAD Assignment



This IC substrate should be floating

Note2: To ensure that the IC functions properly, please bond all of VCC and VSS pins.

Note3: The 0.1 μ F capacitor between VCC and VSS should be placed to IC as close as possible.

6. SIGNAL DESCRIPTION

6.1. Serial Data Output (Q)

This output signal is used to transfer data serially out of the device. Data is shifted out on the falling edge of Serial Clock (C).

6.2. Serial Data Input (D)

This input signal is used to transfer data serially into the device. It receives instructions, addresses, and the data to be programmed. Values are latched on the rising edge of Serial Clock (C).

6.3. Serial Clock (C)

This input signal provides the timing of the serial interface. Instructions, addresses, or data present at Serial Data Input (D) are latched on the rising edge of Serial Clock (C). Data on Serial Data Output (Q) changes after the falling edge of Serial Clock (C).

6.4. Chip Select (SB)

When this input signal is High, the device is deselected. Driving Chip Select (SB) Low enables the device, placing it in the active power mode.

After Power-up, a falling edge on Chip Select (SB) is required prior to the start of any instruction.

6.5. Hold (HOLDB)

The Hold (HOLDB) signal is used to pause any serial communications with the device without deselecting the device. During the Hold condition, the Serial Data Output (Q) is high impedance, and Serial Data Input (D) and Serial Clock (C) are Don't Care.

To start the Hold condition, the device must be selected, with Chip Select (SB) driven Low.

7. SPI MODES

These devices can be driven by a microcontroller with its SPI peripheral running in either of the two following modes:

- CPOL=0, CPHA=0
- CPOL=1, CPHA=1

For these two modes, input data is latched in on the rising edge of Serial Clock (C), and output data is available from the falling edge of

Serial Clock (C).

The difference between the two modes, as shown in Figure 2, is the clock polarity when the bus master is in Stand-by mode and not transferring data:

- C remains at 0 for (CPOL=0, CPHA=0)
- C remains at 1 for (CPOL=1, CPHA=1)

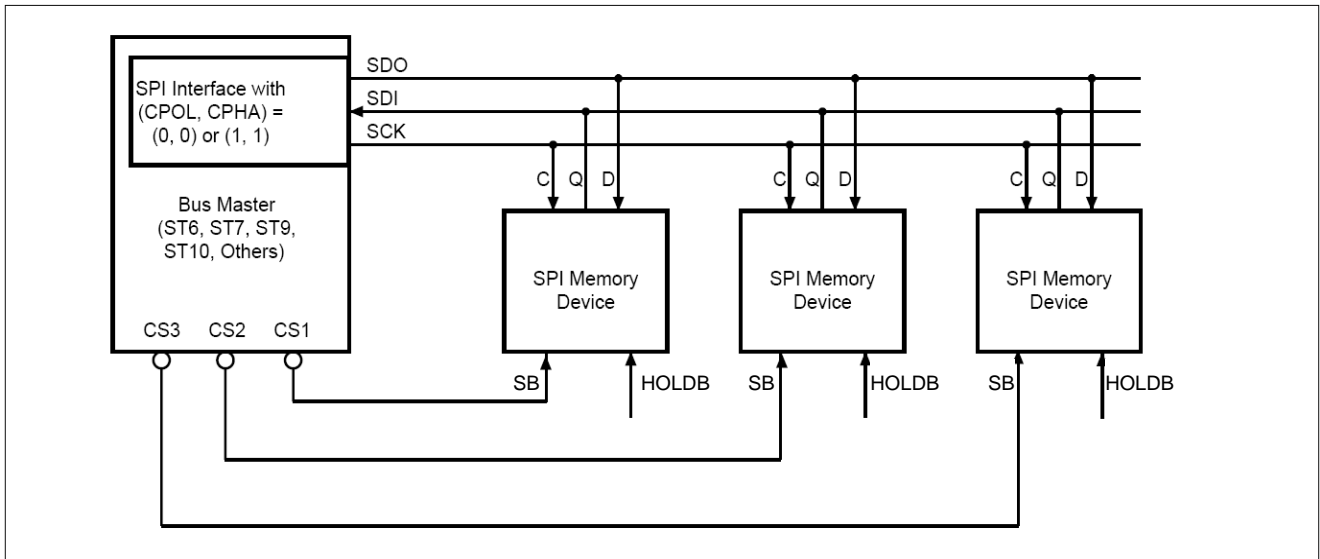

Note: Hold (HOLDB) signals should be driven, High or Low as appropriate.

Figure1. Bus Master and Memory Devices on the SPI Bus

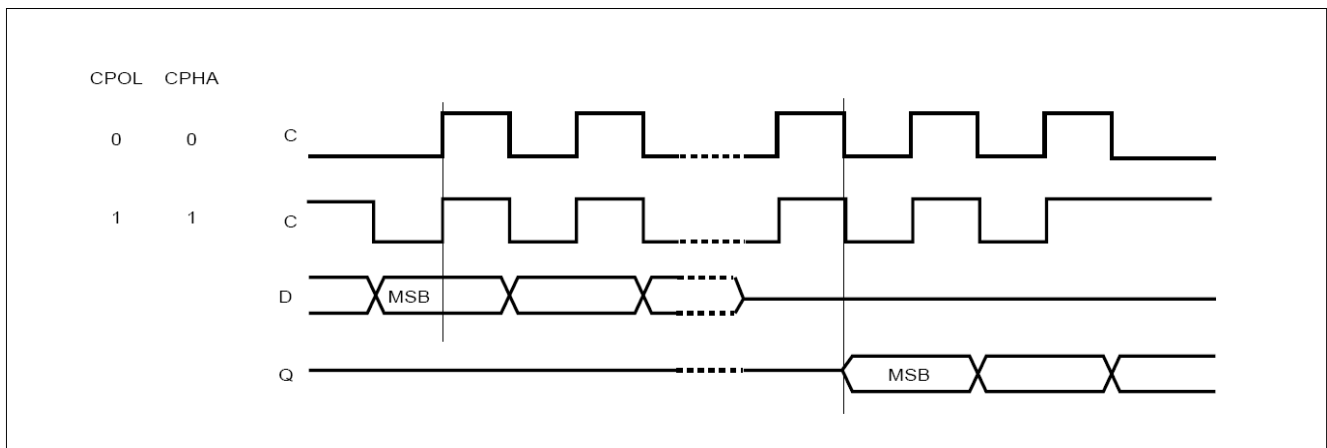

Figure2. SPI Modes Supported

8. OPERATING FEATURES

8.1. Active Power, Stand-by Power

When Chip Select (SB) is Low, the device is enabled with current consumption of ICC2 in the Active Power mode (regardless of whether or not the clock is toggled). When Chip Select (SB) is High, the device is disabled, but it remains in the Active Power mode until all internal cycles are completed. After that, the device enters standby mode, dropping the current to ICC1.

8.2. Protection Modes

The environments where non-volatile memory devices are used can be very noisy. No SPI device can operate correctly in the presence of excessive noise. To help combat this, the GPR26L320A boasts the following data protection mechanisms:

- Power-On Reset and an internal timer (tPUW) can provide protection against inadvertent changes while the power supply is outside the operating specification.

8.3. Hold Condition

The Hold (HOLDB) signal is used to pause any serial communications with the device without resetting the clocking sequence.

To enter the Hold condition, the device must be selected, with Chip Select (SB) Low.

The Hold condition starts on the falling edge of the Hold (HOLD) signal, provided that this coincides with Serial Clock (C) being Low (as shown in Figure 3).

The Hold condition ends on the rising edge of the Hold (HOLDB) signal, provided that this coincides with Serial Clock (C) being Low.

If the falling edge does not coincide with Serial Clock (C) being Low, the Hold condition starts after Serial Clock (C) next goes Low. Similarly, if the rising edge does not coincide with Serial Clock (C) being Low, the Hold condition ends after Serial Clock (C) next goes Low. (This is shown in Figure 2).

During the Hold condition, the Serial Data Output (Q) is high impedance, and Serial Data Input (D) and Serial Clock (C) are Don't Care.

Normally, the device is kept selected, with Chip Select (SB) driven Low, for the whole duration of the Hold condition. This is to ensure that the state of the internal logic remains unchanged from the moment of entering the Hold condition.

If Chip Select (SB) goes High while the device is in the Hold condition, this has the effect of resetting the internal logic of the device. To restart communication with the device, it is necessary to drive Hold (HOLDB) High, and then to drive Chip Select (SB) Low. This prevents the device from going back to the Hold condition.

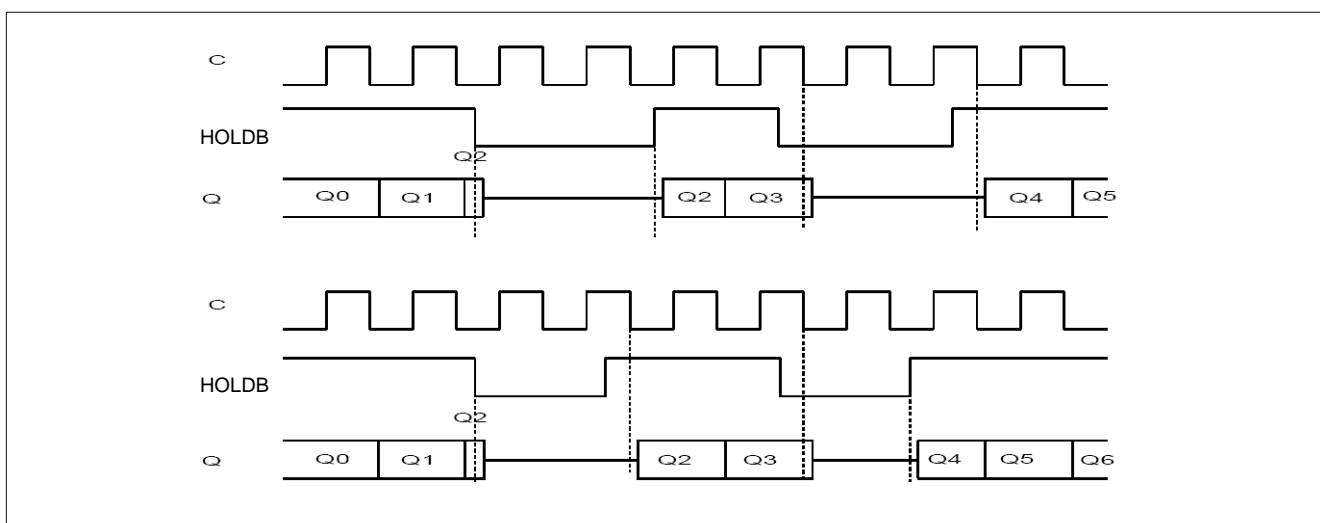

Figure3. Hold Condition Activation (for data output only)

9. INSTRUCTIONS

All instructions, addresses and data are shifted in and out of the device, most significant bit first.

Serial Data Input (D) is sampled on the first rising edge of Serial Clock (C) after Chip Select (SB) is driven Low. Then, the one-byte instruction code must be shifted in to the device, most significant bit first, on Serial Data Input (D), each bit being latched on the rising edges of Serial Clock (C).

The instruction set is listed in Table 1.

Every instruction sequence starts with a one-byte instruction code. Depending on the instruction, this might be followed by address bytes, or by data bytes, or by both or none.

In the case of a Read Data Bytes (READ), Read Data Bytes at Higher Speed (Fast_Read), the shifted-in instruction sequence is followed by a data-out sequence. Chip Select (SB) can be driven High after any bit of the data-out sequence is being shifted out.

Table1. Instruction Set

Instruction	Description	One-byte Instruction Code		Address Bytes	Dummy Bytes	Data Bytes
READ	Read Data Bytes	0000 0011	03h	3	0	1 to ∞
FAST_READ	Read Data Bytes at Higher Speed	0000 1011	0Bh	3	1	1 to ∞

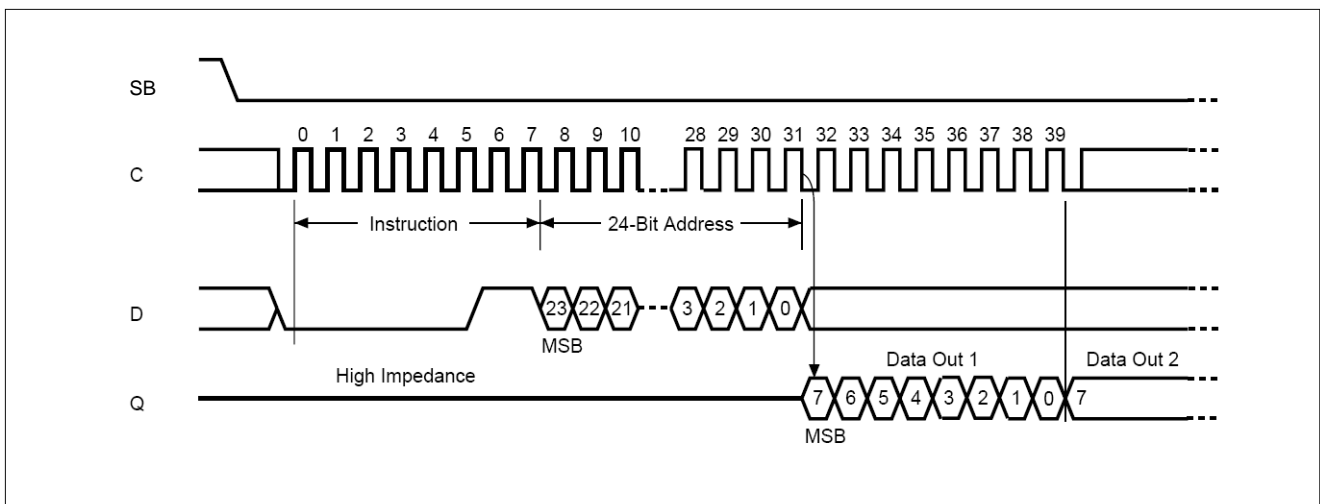

Note: Address bits A23, A22 is Don't Care.

Figure4. Read Data Bytes (READ) Instruction Sequence and Data-Out Sequence

9.1. Read Data Bytes (READ)

The device is first selected by driving Chip Select (SB) Low. The instruction code for the Read Data Bytes (READ) instruction is followed by a 3-byte address (A23-A0), each bit being latched-in during the rising edge of Serial Clock (C). Then the memory contents, at that address, is shifted out on Serial Data Output (Q), each bit being shifted out, at a maximum frequency f_R , during the falling edge of Serial Clock (C).

The instruction sequence is shown in Figure 4. The first byte addressed can be at any location. The address is automatically

incremented to the next higher address after each byte of data is shifted out. The whole memory can, therefore, be read with a single Read Data Bytes (READ) instruction. When the highest address is reached, the address counter rolls over to 000000h, allowing the read sequence to be continued indefinitely.

The Read Data Bytes (READ) instruction is terminated by driving Chip Select (SB) High. Chip Select (SB) can be driven High at any time during data output.

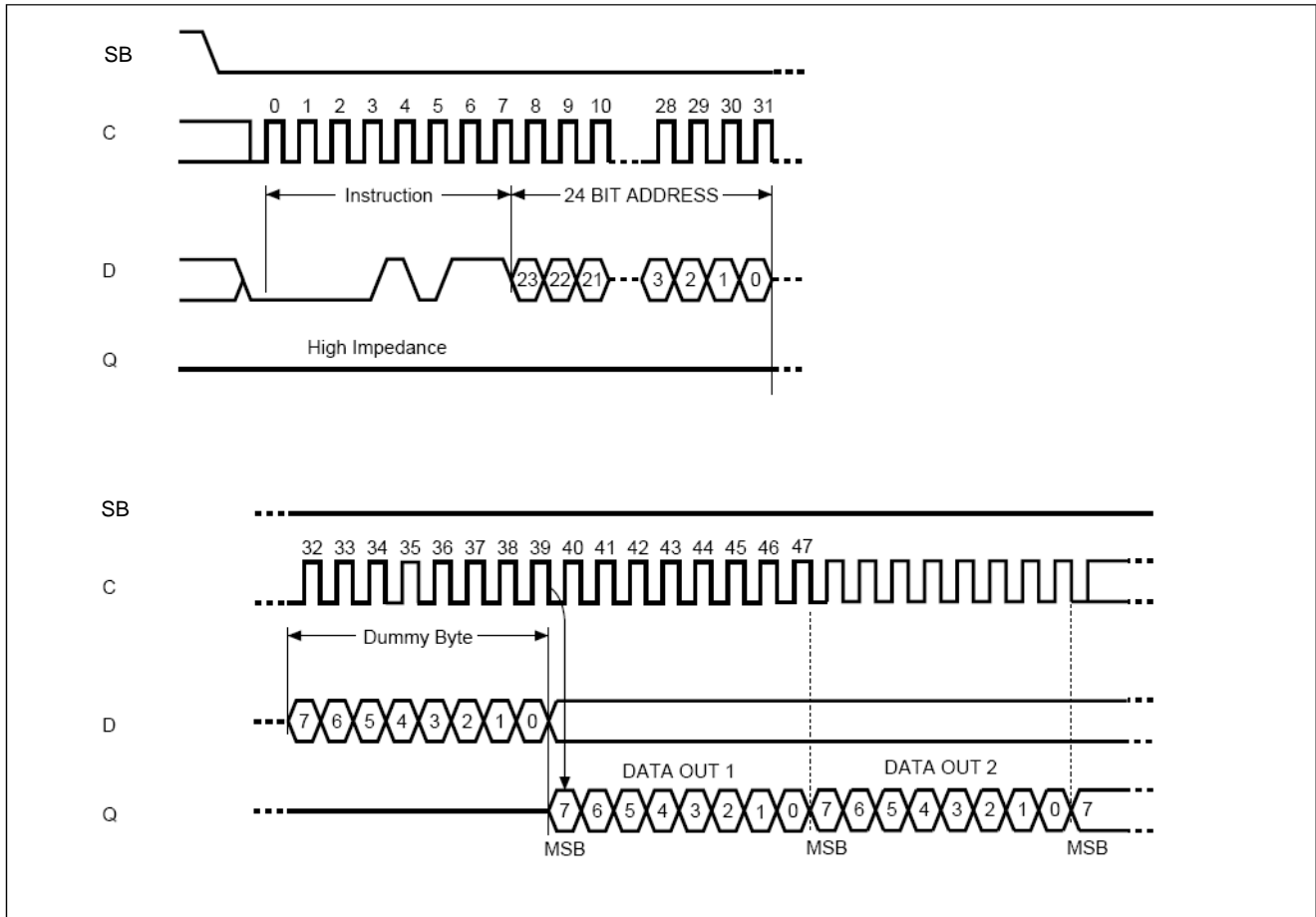

Figure5. Read Data Bytes at Higher Speed (FAST_READ) Instruction Sequence and Data-Out Sequence

9.2. Read Data Bytes at Higher Speed (FAST_READ)

The device is first selected by driving Chip Select (SB) Low. The instruction code for the Read Data Bytes at Higher Speed (FAST_READ) instruction is followed by a 3-byte address (A23-A0) and a dummy byte, each bit being latched-in during the rising edge of Serial Clock (C). Then the memory contents, at that address, is shifted out on Serial Data Output (Q), each bit being shifted out, at a maximum frequency f_C , during the falling edge of Serial Clock (C).

The instruction sequence is shown in Figure 5. The first byte addressed can be at any location. The address is automatically

incremented to the next higher address after each byte of data is shifted out. The whole memory can, therefore, be read with a single Read Data Bytes at Higher Speed (FAST_READ) instruction. When the highest address is reached, the address counter rolls over to 000000h, allowing the read sequence to be continued indefinitely.

The Read Data Bytes at Higher Speed (FAST_READ) instruction is terminated by driving Chip Select (SB) High. Chip Select (SB) can be driven High at any time during data output.

10. POWER-UP AND POWER-DOWN

At Power-up and Power-down, the device must not be selected (that is Chip Select (SB) must follow the voltage applied on VCC) until VCC reaches the correct value:

- VCC (min) at Power-up, and then for a further delay of tVSL.
- VSS at Power-down

Usually a simple pull-up resistor on Chip Select (SB) can be used to insure safe and proper Power-up and Power-down.

To avoid data corruption and inadvertent write operations during power up, a Power on Reset (POR) circuit is included. The logic inside the device is held reset while VCC is less than the POR threshold value, VWI – all operations are disabled, and the device does not respond to any instruction.

These values are specified in Table 2.

If the delay, tVSL, has elapsed, after VCC has risen above VCC (min), the device can be selected for READ instructions even if the tPUW delay is not yet fully elapsed.

- At Power-up, the device is in the following state:
- The device is in the Standby mode.

Normal precautions must be taken for supply rail decoupling, to stabilize the VCC feed. Each device in a system should have the VCC rail decoupled by a suitable capacitor close to the package pins.

(Generally, this capacitor is of the order of 0.1uF).

At Power-down, when VCC drops from the operating voltage, to below the POR threshold value, VWI, all operations are disabled and the device does not respond to any instruction.

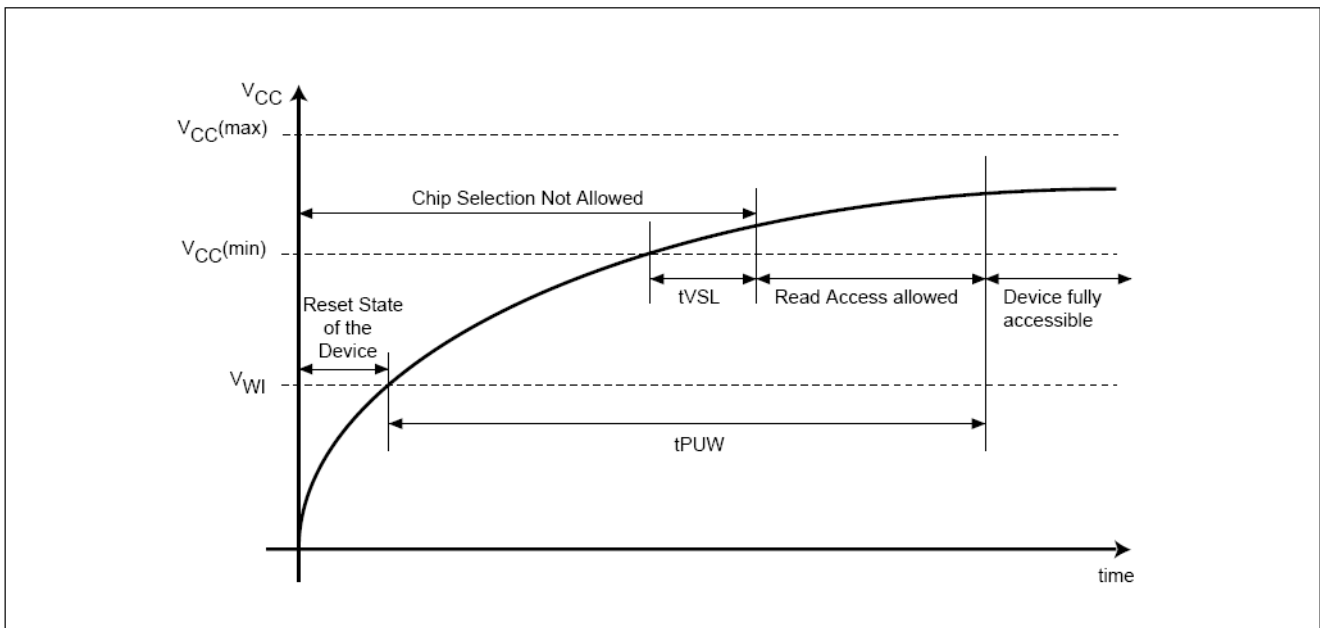

Figure6. Power-up Timing

Table2. Power-Up Timing

Symbol	Parameter	Min.	Max.	Unit
t _{VSL} ¹	V _{CC(min)} to SB low	30	-	us

Note1: These parameters are characterized only.

11. MAXIMUM RATING

Stressing the device above the rating listed in the "Absolute Maximum Ratings" table may cause permanent damage to the device. These are stress ratings only and operation of the device at these or any other conditions above those indicated in the

Operating sections of this specification is not implied. Exposure to Absolute Maximum Rating conditions for extended periods may affect device reliability.

Table3. Absolute Maximum Ratings

Symbol	Parameter	Min.	Max.	Unit
T _{STG}	Storage Temperature	-65	150	°C
T _{LEAD}	Lead Temperature during Soldering ¹	-	260 ²	°C
V _{IO}	Input and Output Voltage (with respect to Ground)	-0.6	4.0	V
V _{CC}	Supply Voltage	-0.6	4.0	V
V _{ESD}	Electrostatic Discharge Voltage (Human Body model) ³	-2000	2000	V

Note1: Compliant with the ECOPACK[®] 7191395 specification for lead-free soldering processes.

Note2: Not exceeding 250°C for more than 30 seconds, and peaking at 260°C.

Note3: JEDEC Std JESD22-A114A (C1=100 pF, R1=1500 Ω, R2=500 Ω).

12. DC AND AC PARAMETERS

This section summarizes the operating and measurement conditions, and the DC and AC characteristics of the device. The parameters in the DC and AC Characteristic tables that follow are derived from tests performed under the Measurement Conditions

summarized in the relevant tables. Designers should check that the operating conditions in their circuit match the measurement conditions when relying on the quoted parameters.

Table4. Operating Conditions

Symbol	Parameter	Min.	Max.	Unit
V _{CC}	Supply Voltage	2.7	3.6	V
T _A	Ambient Operating Temperature	0	70	°C

Table5. AC Measurement Conditions

Symbol	Parameter	Min.	Max.	Unit
C _L	Load Capacitance	30		pF
	Input Rise and Fall Times	-	5	ns
	Input Pulse Voltages	0.2V _{CC} to 0.8V _{CC}		V
	Input Timing Reference Voltages	0.3V _{CC} to 0.7V _{CC}		V
	Output Timing Reference Voltages	V _{CC} /2		V

Note: Output Hi-Z is defined as the point where data out is no longer driven.

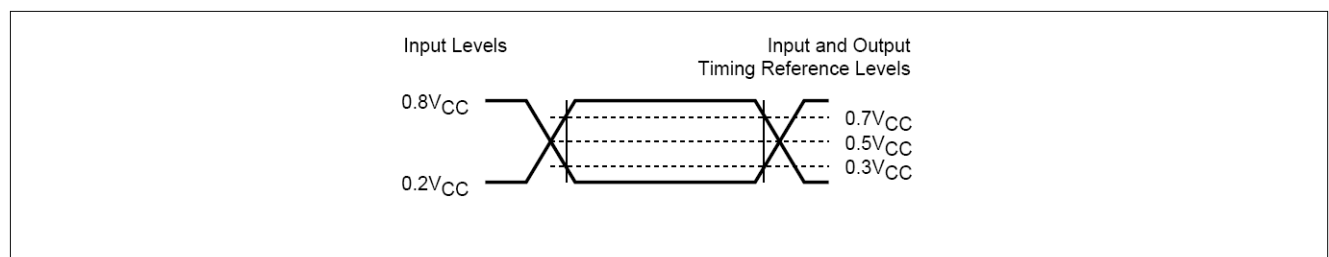

Figure7. AC Measurement I/O Waveform

Table6. Capacitance

Symbol	Parameter	Test Condition	Min.	Max.	Unit
C _{OUT}	Output Capacitance (Q)	V _{OUT} = 0V	-	8	pF
C _{IN}	Input Capacitance (other pins)	V _{IN} = 0V	-	6	pF

Note: Sampled only, not 100% tested, at TA=25°C and a frequency of 20 MHz.

Table7. DC Characteristics

Symbol	Parameter	Test Condition (in addition to those in Table 8)	Min.	Max.	Unit
I _{LI}	Input Leakage Current		-	± 2	uA
I _{LO}	Output Leakage Current		-	± 2	uA
I _{CC1}	Standby Current	SB = VCC, V _{IN} = VSS or VCC	-	15	uA
I _{CC2}	Operating Current (READ)	C = 0.1VCC / 0.9.VCC at 50MHz, Q = open	-	8	mA
		C = 0.1VCC / 0.9.VCC at 20MHz, Q = open	-	4	mA
V _{IL}	Input Low Voltage		- 0.5	0.3VCC	V
V _{IH}	Input High Voltage		0.7VCC	VCC+0.4	V
V _{OL}	Output Low Voltage	I _{OL} = 1.6mA	-	0.4	V
V _{OH}	Output High Voltage	I _{OH} = -100 uA	VCC- 0.2	-	V

Note: Once SB is low, the device will be enabled with current consumption ICC2 regardless of whether or not C (serial clock) is toggled.

Table8. AC Characteristics

Test conditions specified in Table 4 and Table 5						
Symbol	Alt.	Parameter	Min.	Typ.	Max.	Unit
f _C	f _C	Clock Frequency for the following instructions: FAST_READ	D.C.	-	50	MHz
f _R		Clock Frequency for READ instructions	D.C.	-	20	MHz
t _{CH} ¹	t _{CLH}	Clock High Time	9	-	-	ns
t _{CL} ¹	t _{CLL}	Clock Low Time	9	-	-	ns
t _{CLCH} ²		Clock Rise Time ³ (peak to peak)	0.1	-	-	V/ns
t _{CHCL} ²		Clock Fall Time ³ (peak to peak)	0.1	-	-	V/ns
t _{SLCH}	t _{CSS}	SB Active Setup Time (relative to C)	5	-	-	ns
t _{CHSL}		SB Not Active Hold Time (relative to C)	5	-	-	ns
t _{DVCH}	t _{DSU}	Data In Setup Time	2	-	-	ns
t _{CHDX}	t _{DH}	Data In Hold Time	5	-	-	ns
t _{CHSH}		SB Active Hold Time (relative to C)	5	-	-	ns
t _{SHCH}		SB Not Active Setup Time (relative to C)	5	-	-	ns
t _{SHSL}	t _{CSH}	SB Deselect Time	100	-	-	ns
t _{SHOZ} ²	t _{DIS}	Output Disable Time	-	-	8	ns
t _{CLOV}	t _V	Clock Low to Output Valid	-	-	8	ns
t _{CLOX}	t _{HO}	Output Hold Time	0	-	-	ns
t _{HLCH}		HOLDB Setup Time (relative to C)	5	-	-	ns
t _{CHHH}		HOLDB Hold Time (relative to C)	5	-	-	ns
t _{HHCH}		HOLD Setup Time (relative to C)	5	-	-	ns
t _{CHHL}		HOLD Hold Time (relative to C)	5	-	-	ns
t _{HHOZ} ²	t _{LZ}	HOLD to Output Low-Z	-	-	8	ns
t _{HLOZ} ²	t _{HZ}	HOLDB to Output High-Z	-	-	8	ns

Note1: t_{CH} + t_{CL} must be greater than or equal to 1/ f_C.

Note2: Value guaranteed by characterization, not 100% tested in production.

Note3: Expressed as a slew-rate.

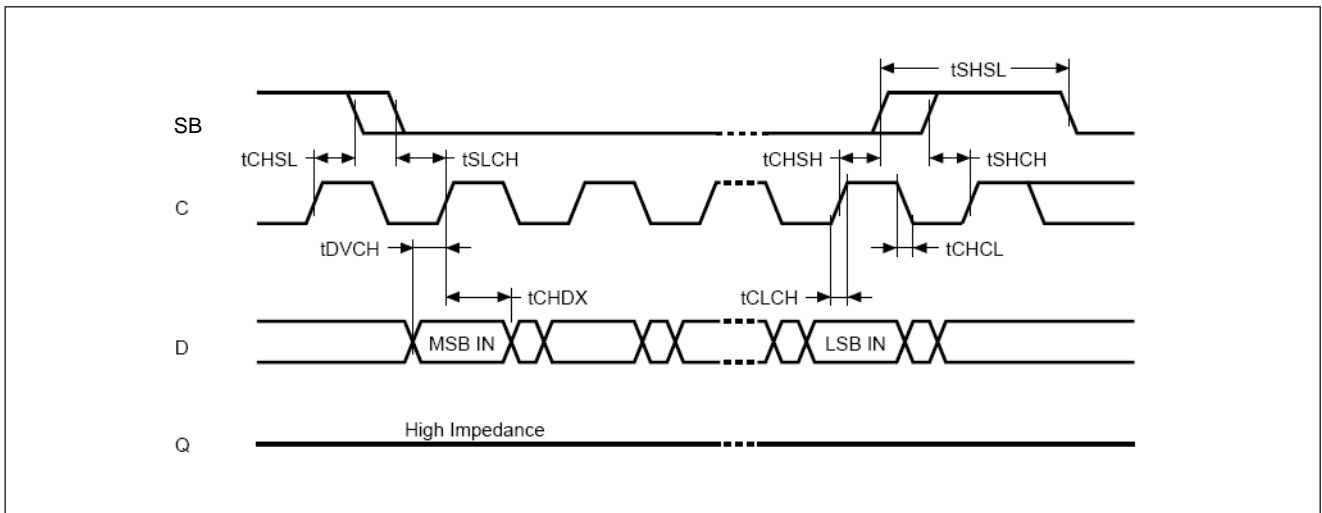

Figure8. Serial Input Timing

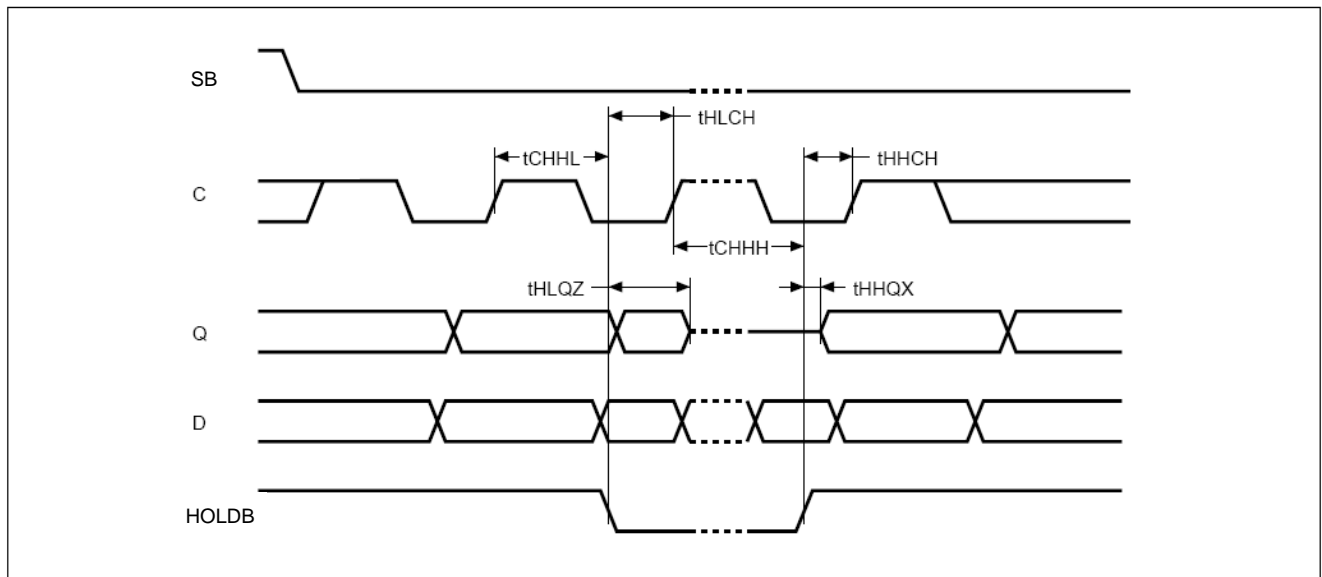

Figure9. Hold Timing

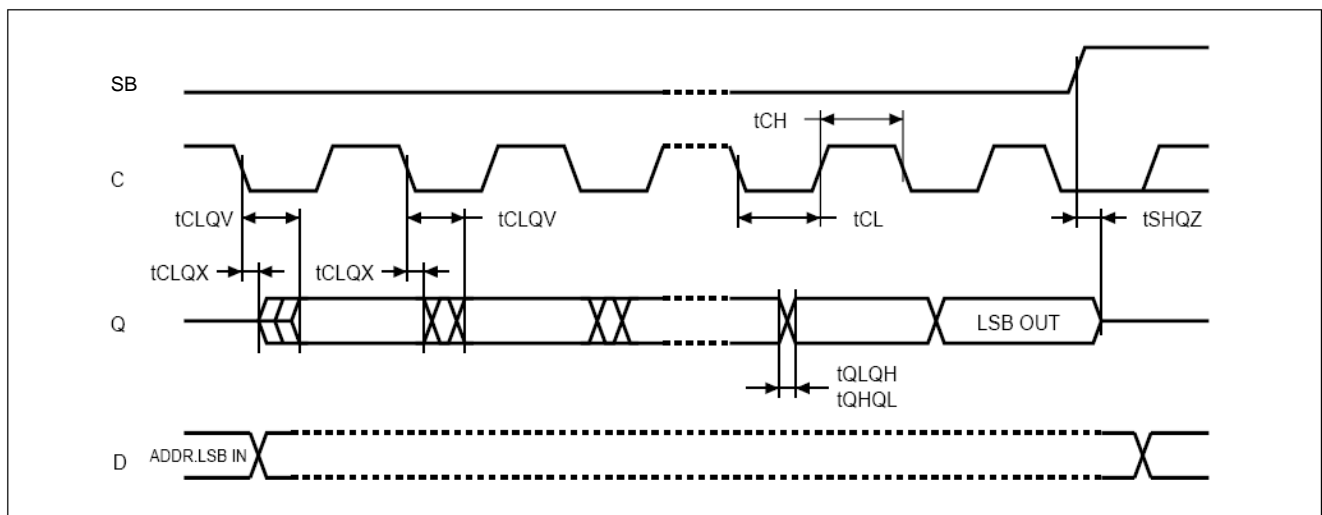

Figure10. Output Timing



13. PACKAGE/PAD INFORMATION

13.1. Ordering Information

Product Number	Package Type
GPR26L320A-NnnV-C	Chip form

Note1: Code number is assigned for customer.

Note2: Code number (N = A - Z or 0 - 9, nn = 00 - 99); version (V = A - Z).

14. DISCLAIMER

The information appearing in this publication is believed to be accurate.

Integrated circuits sold by Generalplus Technology are covered by the warranty and patent indemnification provisions stipulated in the terms of sale only. GENERALPLUS makes no warranty, express, statutory implied or by description regarding the information in this publication or regarding the freedom of the described chip(s) from patent infringement. FURTHERMORE, GENERALPLUS MAKES NO WARRANTY OF MERCHANTABILITY OR FITNESS FOR ANY PURPOSE. GENERALPLUS reserves the right to halt production or alter the specifications and prices at any time without notice. Accordingly, the reader is cautioned to verify that the data sheets and other information in this publication are current before placing orders. Products described herein are intended for use in normal commercial applications. Applications involving unusual environmental or reliability requirements, e.g. military equipment or medical life support equipment, are specifically not recommended without additional processing by GENERALPLUS for such applications. Please note that application circuits illustrated in this document are for reference purposes only.

15. REVISION HISTORY

Date	Revision#	Description	Page
Aug. 13, 2009	1.4	1. Modify 8.1 Active Power, Stand-by Power.	7
		2. Add note to 12.DC AND AC PARAMETERS table 7.	12
May 08, 2009	1.3	1. Delete Package Information.	
		2. Add 5.1 Pad Assignment.	4
May 31, 2007	1.2	Modify the description in Table7. DC Characteristics.	11
Aug. 18, 2006	1.1	1. Modify the "ORDERING INFORMATION" in section 5.	3
		2. Modify the "PACKAGE INFORMATION" in section 15.	14
Aug. 02, 2006	1.0	Original	16