

## **GPY0050A1**

---

### **12-bit ADC with Microphone Preamplifier**

Sep. 25, 2017

Version 1.1

---

## Table of Contents

	<u>PAGE</u>
<b>1. GENERAL DESCRIPTION</b> .....	<b>3</b>
<b>2. FEATURES</b> .....	<b>3</b>
<b>3. BLOCK DIAGRAM</b> .....	<b>3</b>
<b>4. SIGNAL DESCRIPTIONS</b> .....	<b>4</b>
4.1. PAD ASSIGNMENT .....	5
4.2. PACKAGE PIN ASSIGNMENT .....	5
<b>5. FUNCTIONAL DEcriptions</b> .....	<b>6</b>
5.1. SPI SERIAL INTERFACE .....	6
5.1.1. SPI Command Mode Setting.....	6
5.1.2. Command Mode Address Format.....	6
5.1.3. Command Mode Data Format .....	7
5.1.4. SPI Timing .....	8
5.2. ANALOG-TO-DIGITAL CONVERTER .....	13
5.3. ADC S/H TIME .....	14
5.4. MICROPHONE PREAMPLIFIER.....	15
<b>6. ELECTRICAL SPECIFICATIONS</b> .....	<b>16</b>
6.1. ABSOLUTE MAXIMUM RATINGS .....	16
6.2. DC CHARACTERISTICS ( $V_{DD}=5.0V$ , $T_A = 25^{\circ}C$ ) .....	16
<b>7. APPLICATION CIRCUIT</b> .....	<b>17</b>
<b>8. PACKAGE/PAD LOCATIONS</b> .....	<b>18</b>
8.1. ORDERING INFORMATION .....	18
8.2. PACKAGE INFORMATION .....	18
8.2.1. SSOP 20.....	18
8.2.2. SSOP 16.....	19
<b>9. DISCLAIMER</b> .....	<b>20</b>
<b>10. REVISION HISTORY</b> .....	<b>21</b>

## 12-BITS ADC WITH MICROPHONE PREAMPLIFIER

### 1. GENERAL DESCRIPTION

The GPY0050A1 is a 12-bit sampling Analog-to-Digital Converter (ADC) with a synchronous serial interface and differential microphone input preamplifier. The device contains an on-chip control register allowing control of ADC and microphone amplifier via the SPI interface.

### 2. FEATURES

- Wide operating range: 2.2V – 5.5V
- SPI Serial Interface
- One 12-bit ADC (12-bit SAR ADC)
- ADC Sampling Up to 125KHz
- One Microphone Preamplifier with AGC

### 3. BLOCK DIAGRAM

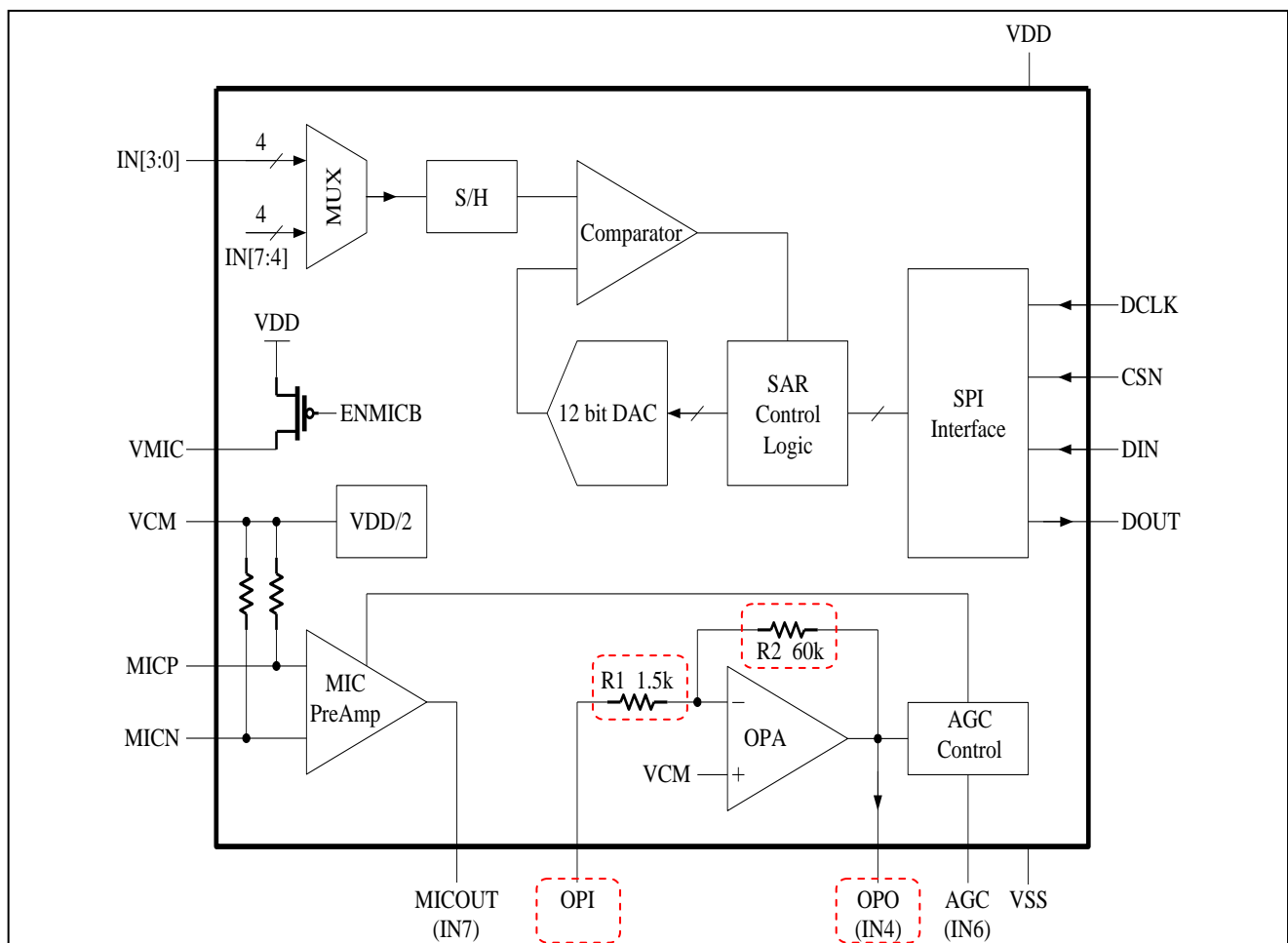

**Note:** When user needs 8 channels ADC, we recommend replacing GPY0050A1 with GPY0050B.

**4. SIGNAL DESCRIPTIONS**
**GPY0050A1-HG08x (SSOP-20)**

Mnemonic	PIN No.	Type	Description	Electrical Characteristics
DOUT	1	O	Serial data output. Data is shifted out on the falling edge of DCLK. This output is high impedance when CSN is high.	-
DIN	2	I	Serial data input. If CSN is low, data is latched on the rising edge of DCLK.	-
DCLK	3	I	Data Clock input	-
CSN	4	I	Chip select. Active Low	-
VDD / VDDA	5 / 6	P	Power VDD	VDD=2.2V ~ 5.5V
IN0	7	I	ADC input channel 0	-
IN1	8	I	ADC input channel 1	-
IN2	9	I	ADC input channel 2	-
IN3	10	I	ADC input channel 3	-
OPO / IN4	11	O / I	OPA Output. / ADC input channel 4	-
OPI	12	I	OPA inverting input.	-
AGC / IN6	13	O / I	AGC control pin. / ADC input channel 6	-
MICOUT / IN7	14	O / I	Microphone preamplifier output. / ADC input channel 7	-
MICN	15	I	Inverting input of the differential microphone signal	-
MICP	16	I	Non-inverting input of the differential microphone signal	-
VCM	17	O	VDD/2. MIC Preamplifier signal ground	VDD/2
VMIC	18	O	Power Switch for Microphone bias	-
VSSA / VSS	19 / 20	P	Power Ground	-

**GPY0050A1-HG01x (SSOP-16)**

Mnemonic	PIN No.	Type	Description	Electrical Characteristics
DOUT	1	O	Serial data output. Data is shifted out on the falling edge of DCLK. This output is high impedance, when CSN is high.	-
DIN	2	I	Serial data input t. If CSN is low, data is latched on the rising edge of DCLK.	-
DCLK	3	I	Data Clock input	-
CSN	4	I	Chip select. Active Low	-
VDD	5	P	Power VDD	VDD=2.2V ~ 5.5V
IN0	6	I	ADC input channel 0	-
IN1	7	I	ADC input channel 1	-
IN2	-	I	ADC input channel 2	-
IN3	-	I	ADC input channel 3	-
OPO / IN4	8	O / I	OPA Output. / ADC input channel 4	-
OPI	9	I	OPA inverting input.	-
AGC / IN6	10	O / I	AGC control pin. / ADC input channel 6	-
MICOUT / IN7	11	O / I	Microphone preamplifier output. / ADC input channel 7	-
MICN	12	I	Inverting input of the differential microphone signal	-
MICP	13	I	Non-inverting input of the differential microphone signal	-
VCM	14	O	VDD/2. MIC Preamplifier signal ground	VDD/2
VMIC	15	O	Power Switch for Microphone bias	-
VSS	16	P	Power Ground	-

## 4.1. PAD Assignment

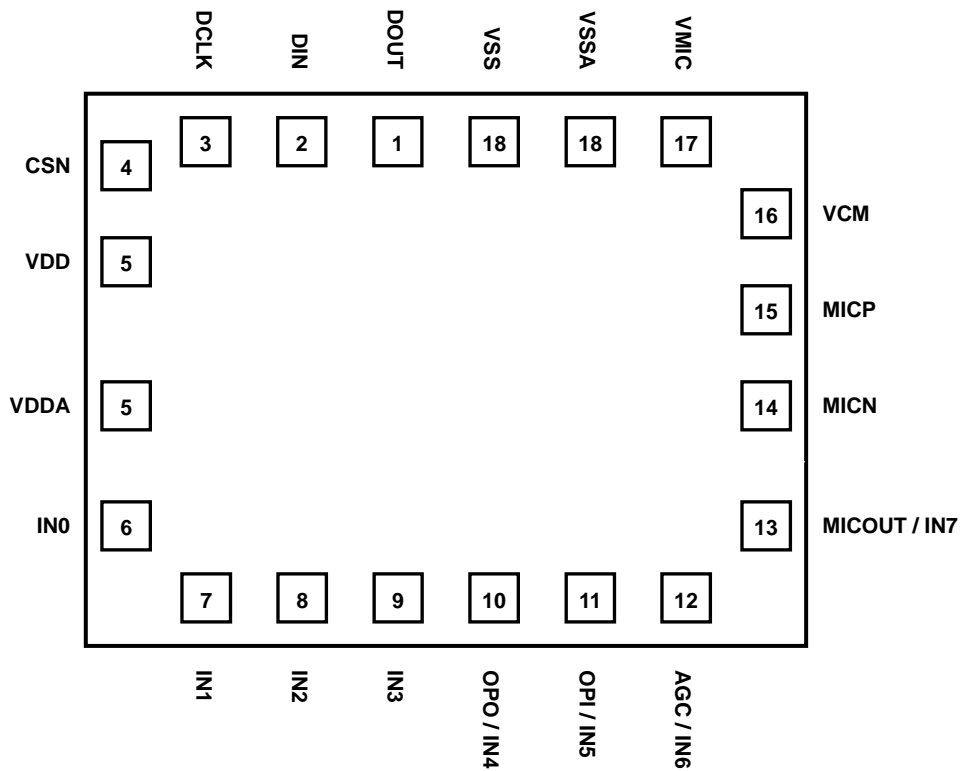

## 4.2. Package Pin Assignment

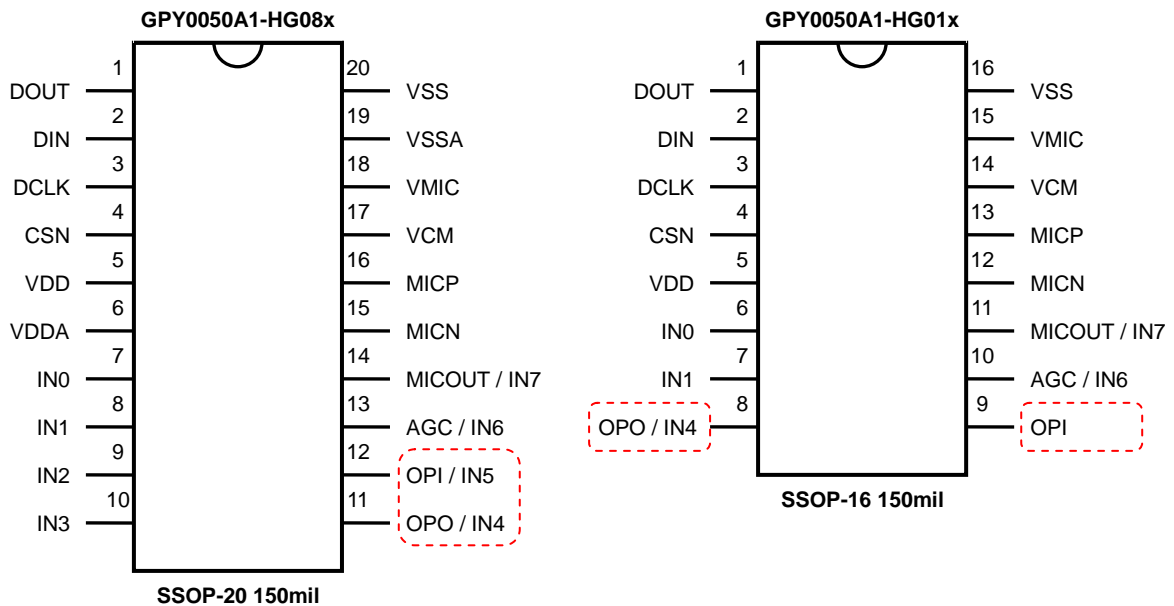

**Note:** When user needs 8 channels ADC, we recommend replacing GPY0050A1 with GPY0050B.

## 5. FUNCTIONAL DESCRIPTIONS

### 5.1. SPI Serial Interface

The GPY0050A1 supports SPI Mode 0 and Mode 3 waveform. When CSN is low, the DIN is latched on the rising edge of DCLK and DOUT is shifted out on the falling edge of DCLK. If CSN is high, it will disable SPI interface, set DOUT pin in high impedance state and maintain the register data. When the GPY0050A1 is power on, the power on reset (POR) will set all of register to default value.

The first command bit, the 'S' bit, must always be high and indicate the start of command input. The second bit, 'R/W' bit, controls Read or Write register. The next two bits (CMD\_ADDR) select register address. The last 4 bits (CMD\_DATA) of data will be written to register.

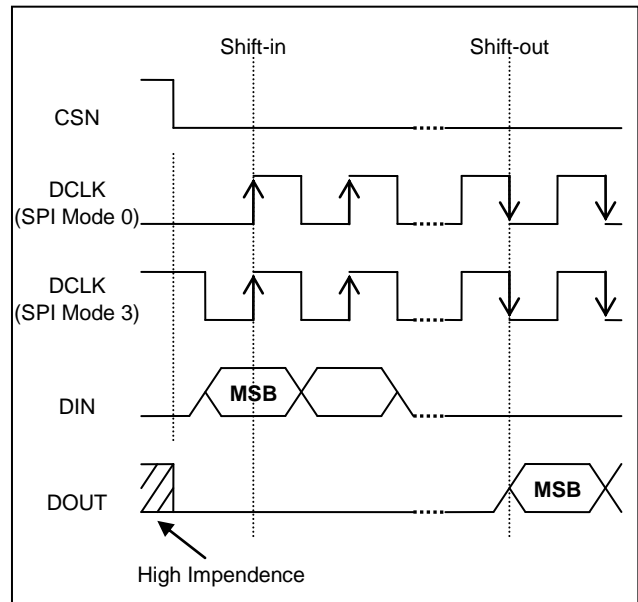

#### 5.1.1. SPI Command Mode Setting

Bit	7(MSB)	6	5	4	3	2	1	0(LSB)
Function	S	R/W	CMD_ADDR		CMD_DATA			

Bit	Function	Type	Description	Condition
7	S	W	Start Bit. Control byte starts with first High bit on DIN.	
6	R/W	R/W	Read / Write signal. 0 = write 1 = read	
4-5	CMD_ADDR	R/W	Command Address	00 → ADC_CHSEL 01 → EN_CTRL 10 → Test Mode 11 → Test Mode
0-3	CMD_DATA	R/W	Command Data	

#### 5.1.2. Command Mode Address Format

CMD_ADDR	Function	Type	Description
00	ADC_CHSEL	R/W	ADC channel selection signals
01	EN_CTRL	R/W	ADC / MIC enable controlling signals.
10	Test Mode	R/W	Test mode

**5.1.3. Command Mode Data Format**
**CMD\_ADDR = 00 : ADC\_CHSEL**

CMD_DATA	Function	Description	Conditions
[3:1]	ADC_CHSEL	ADC channel select signals.	111 = IN7 110 = IN6 101 = IN5 - Not available 100 = IN4 011 = IN3 010 = IN2 001 = IN1 000 = IN0 (Default)
[0]	SFT_RST	Software reset	1 = Reset 0 = Active (Default)

**Note:** When microphone preamplifier enable (EN\_MIC=1), ADC\_CHSEL cannot be set IN5~IN7 channel.

**CMD\_ADDR = 01: EN\_CTRL**

CMD_DATA	Function	Description	Conditions
[3]	EN_ADBIAS	ADC and ADC bias enable signal.	1 = Enable 0 = Disable (Default)
[2]	MOD_ADC	ADC bit mode select signal.	1 = 10-bit mode 0 = 12-bit mode (Default)
[1]	EN_AGC	Microphone AGC Control	1 = Enable 0 = Disable (Default)
[0]	EN_MIC	Microphone enable signal.	1 = Enable 0 = Disable (Default)

5.1.4. SPI Timing

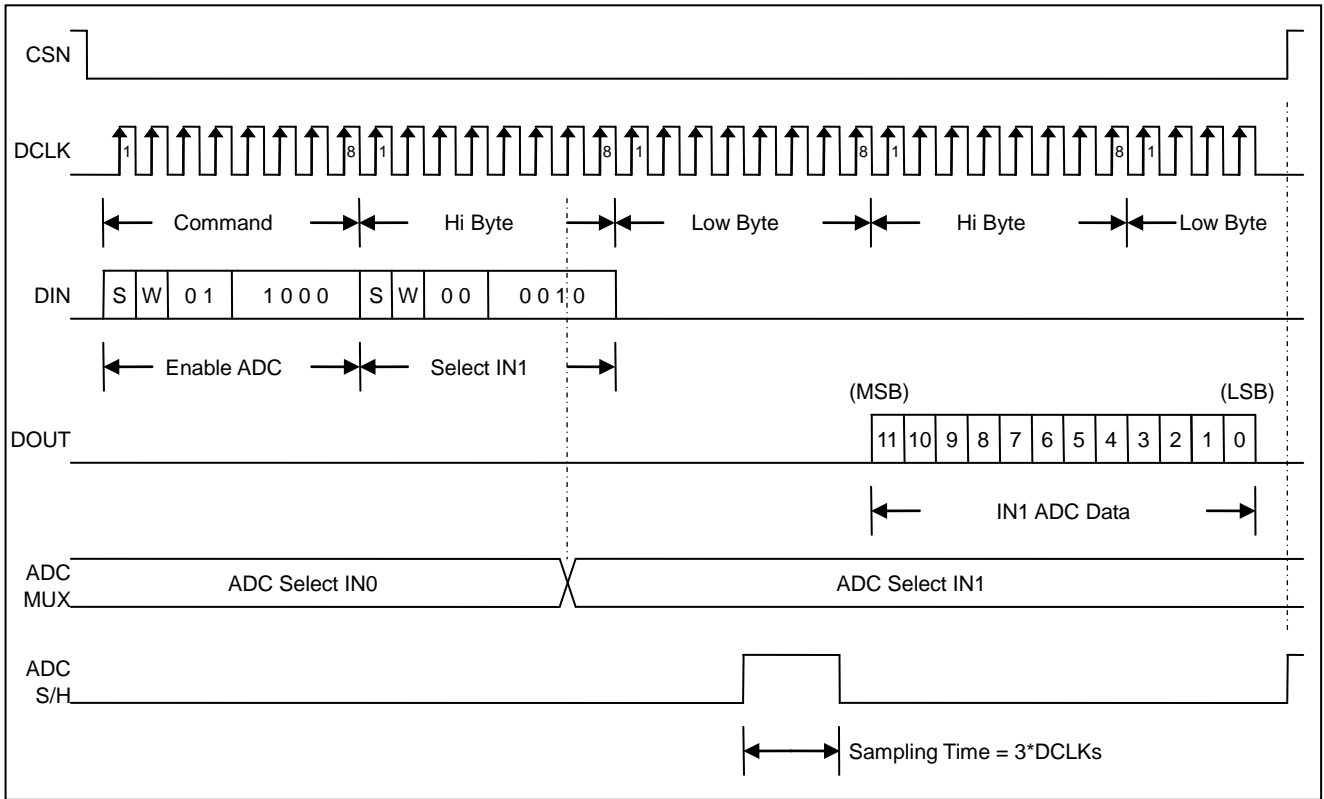

Figure 1. SPI Model 0 – ADC 12 bit Conversion Timing

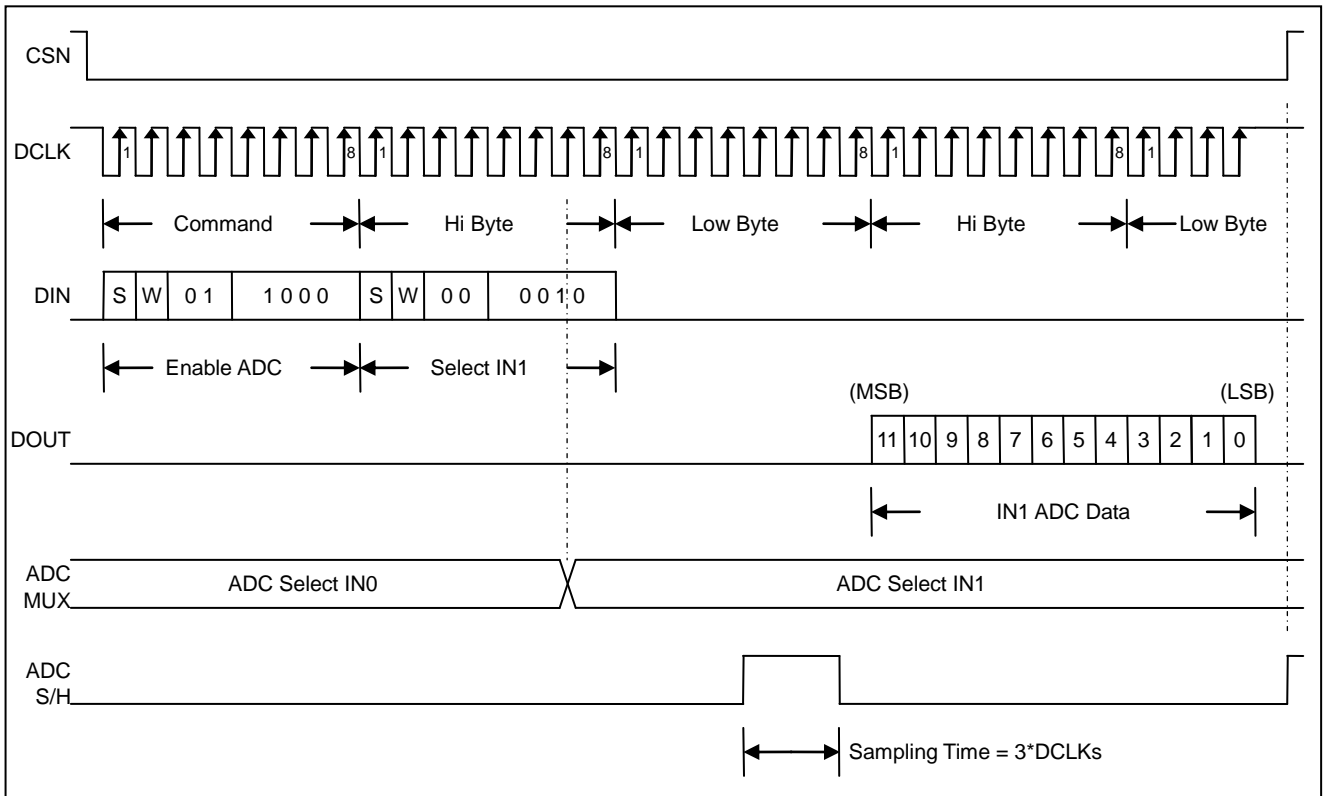

Figure 2. SPI Model 3 – ADC 12-bit Conversion Timing



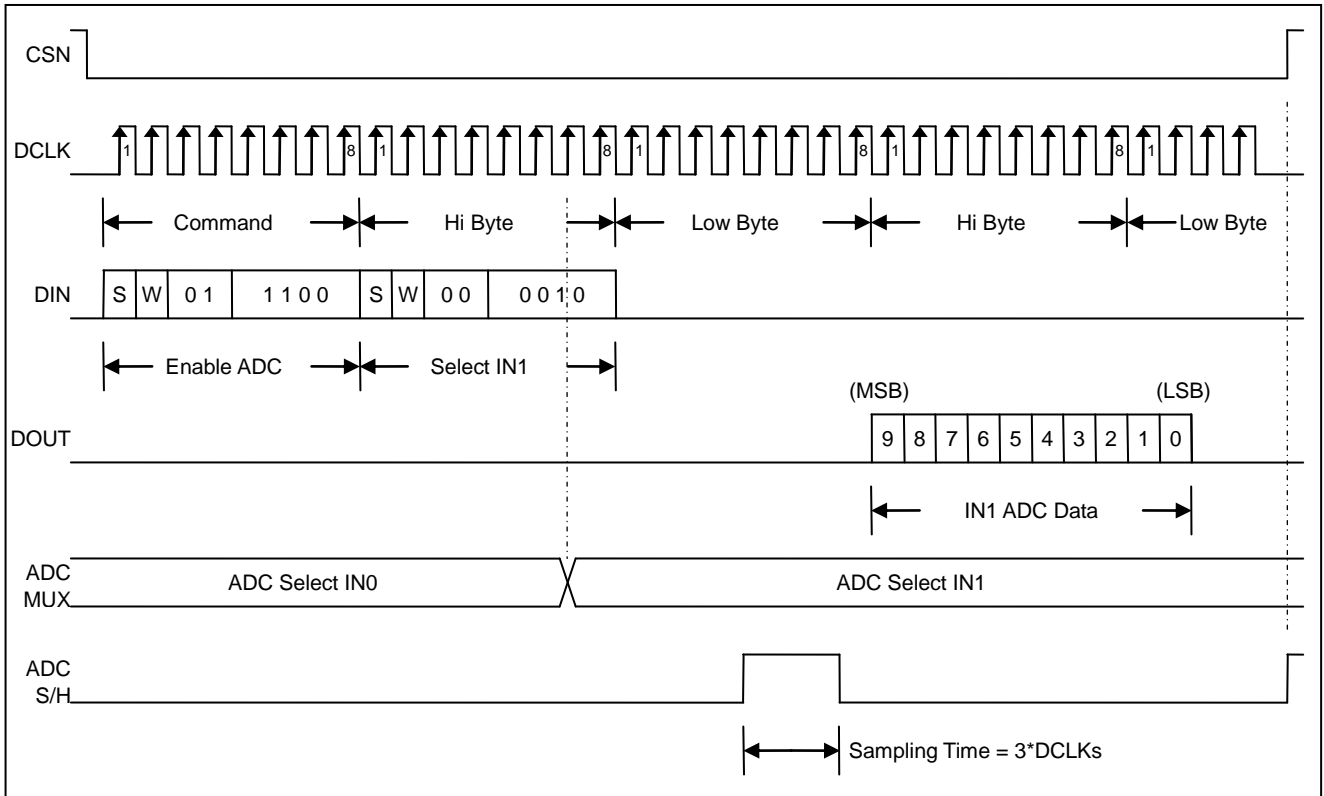

Figure 3. SPI Model 0 – ADC 10-bit Conversion Timing

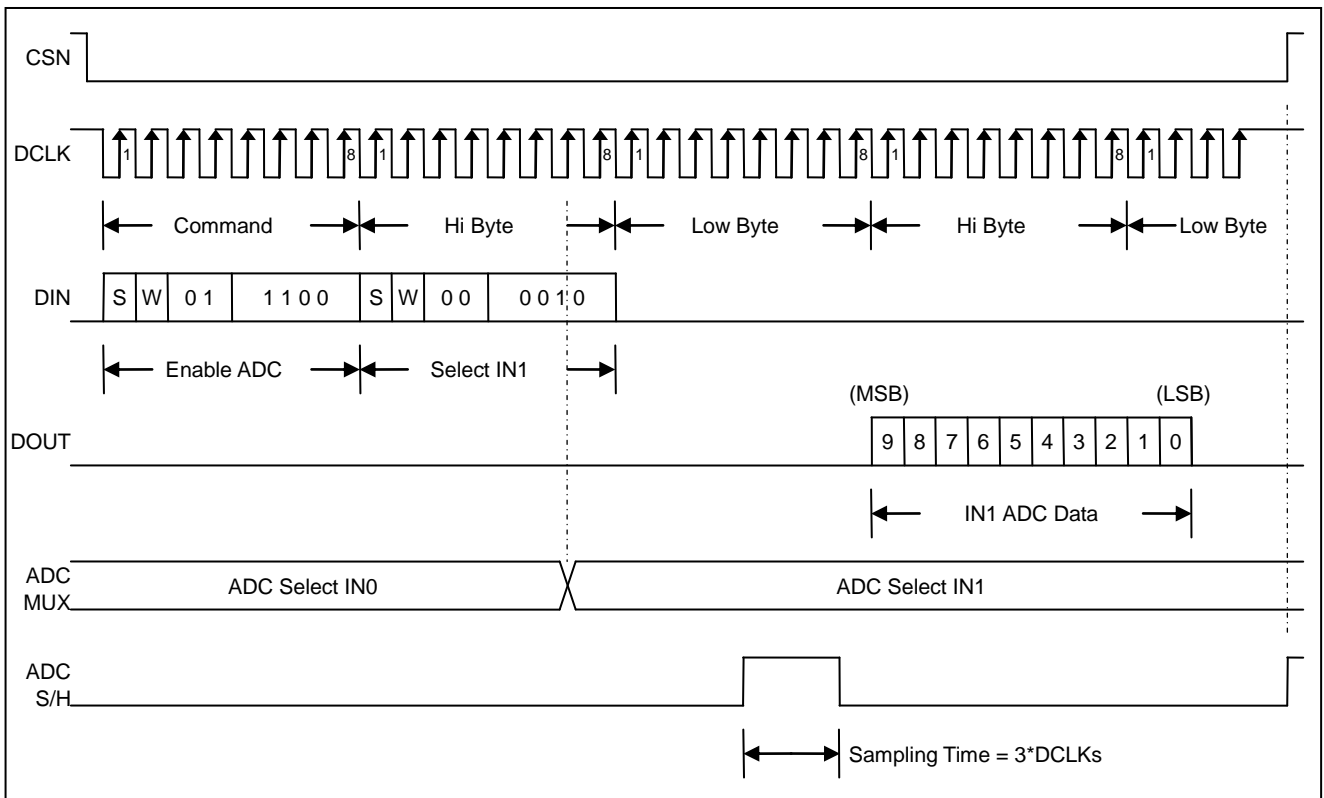

Figure 4. SPI Model 3 – ADC 10-bit Conversion Timing

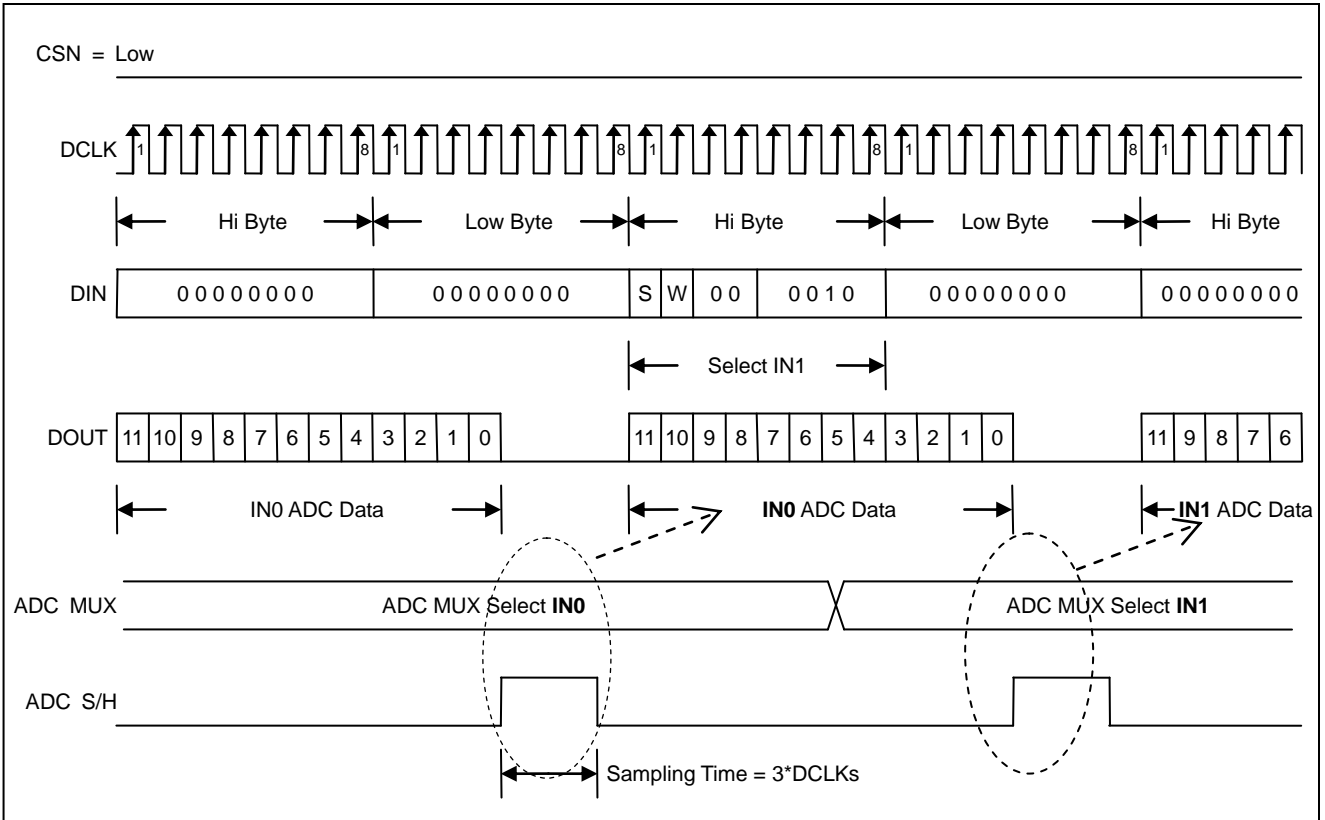

Figure 5. Channel switch during continuous ADC 12-bit conversion.

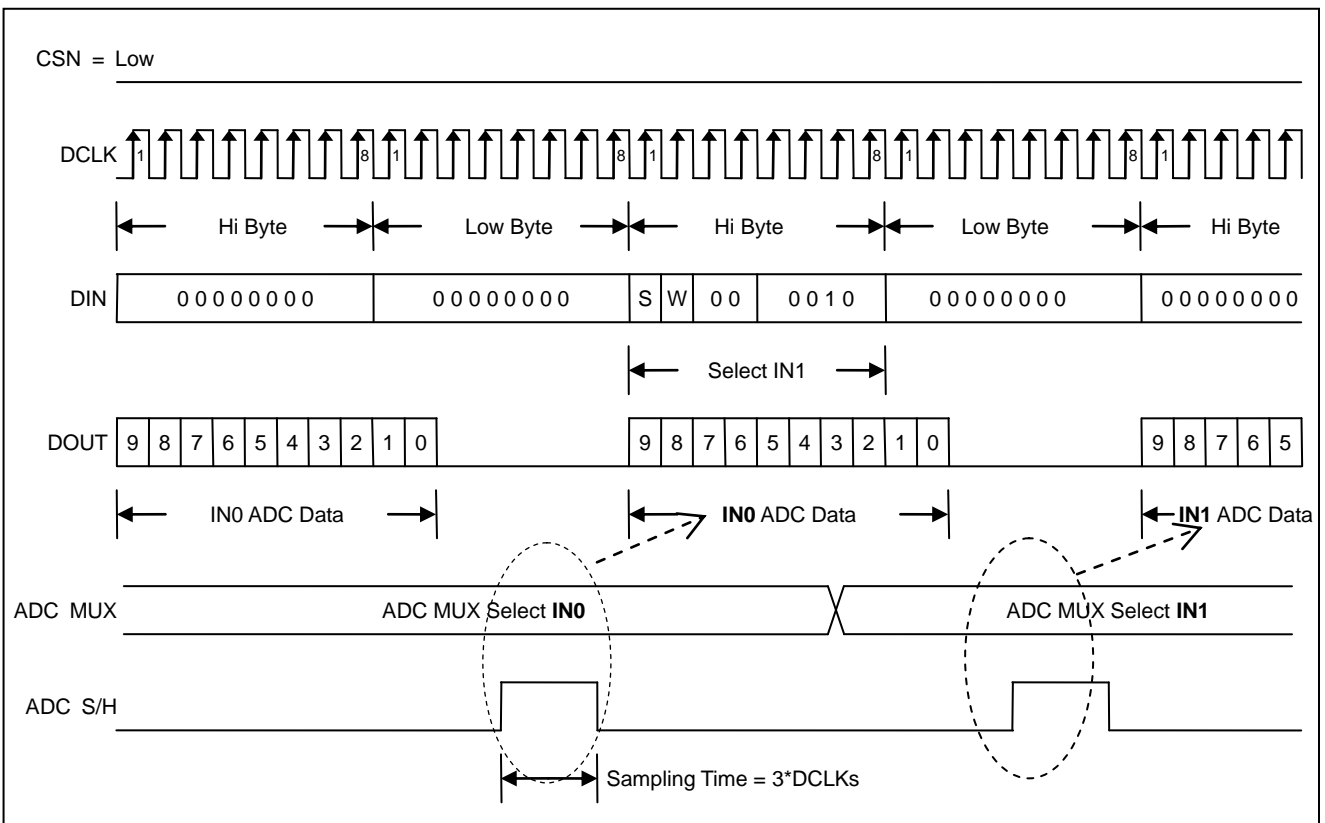

Figure 6. Channel switch during continuous ADC 10-bit conversion.

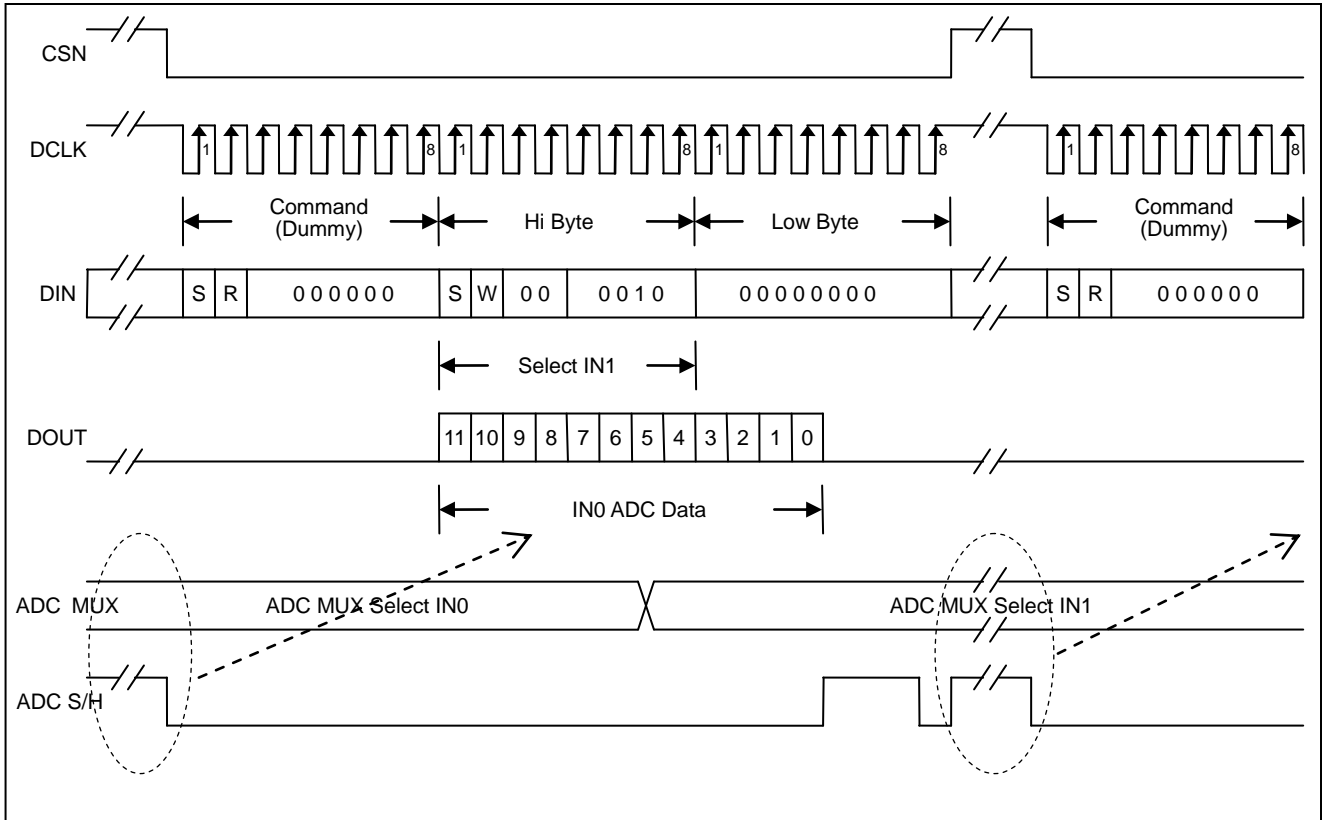

Figure 7. Channel switch during discontinuous ADC 12-bit conversion.

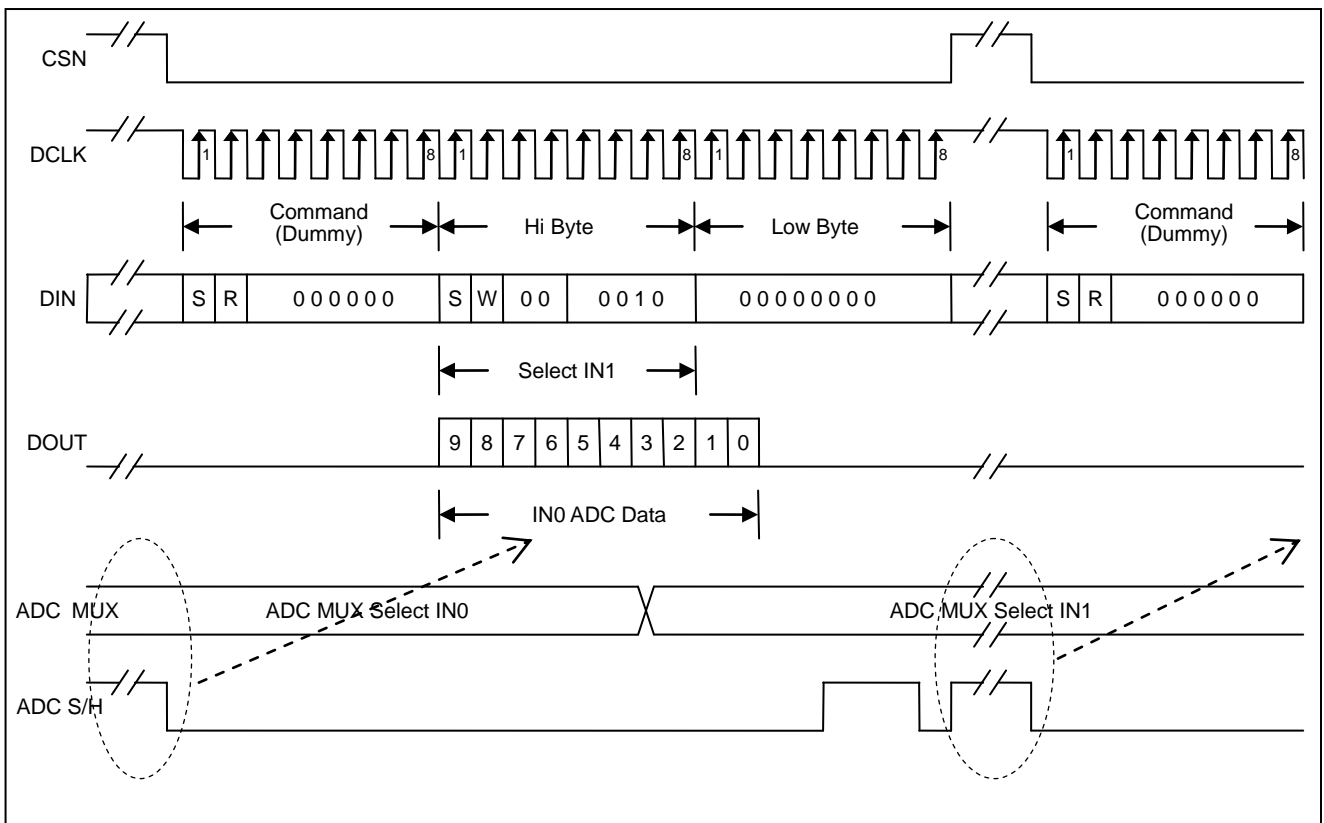

Figure 8. Channel switch during discontinuous ADC 10-bit conversion.

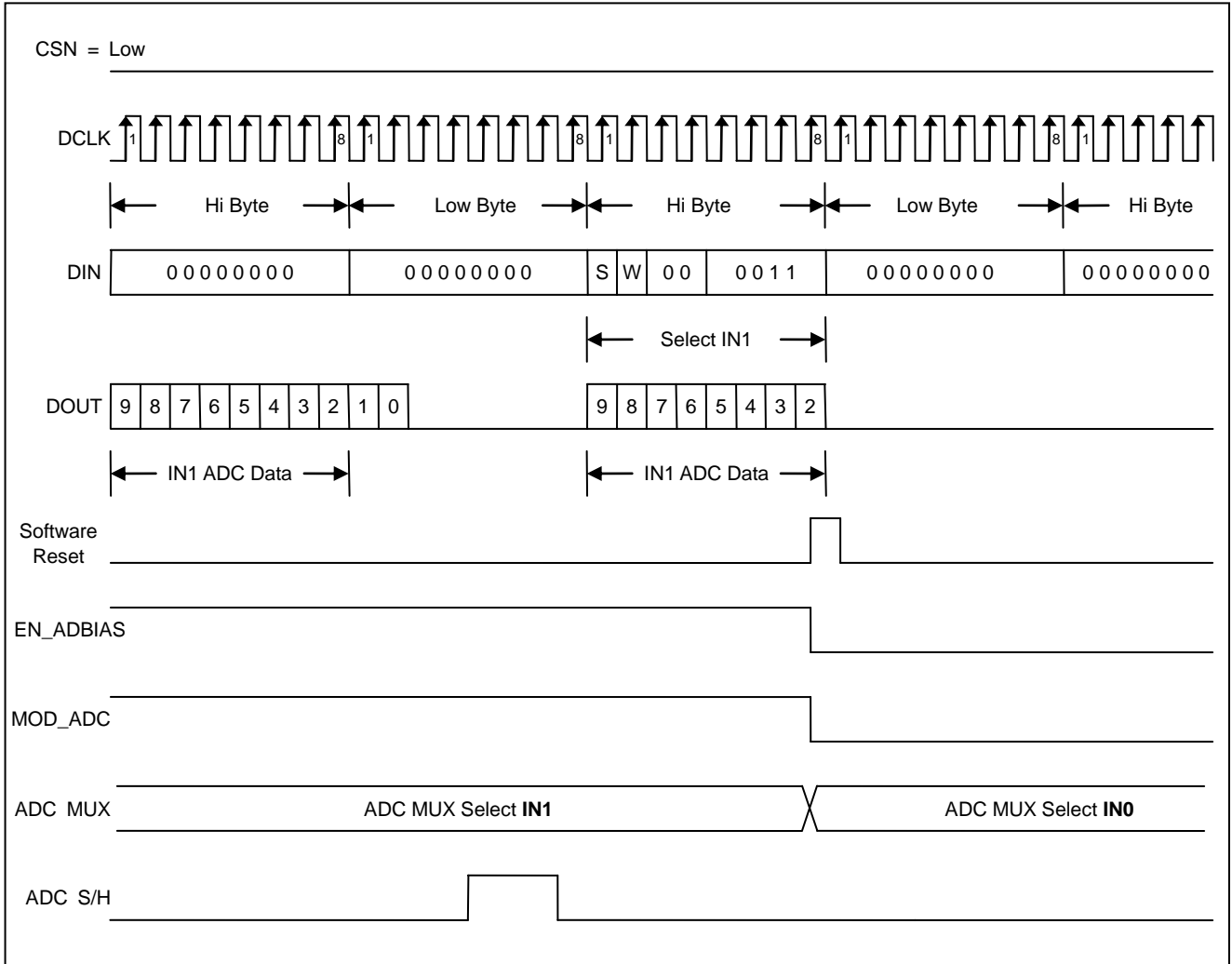

Figure 9. Software Reset Trigger.

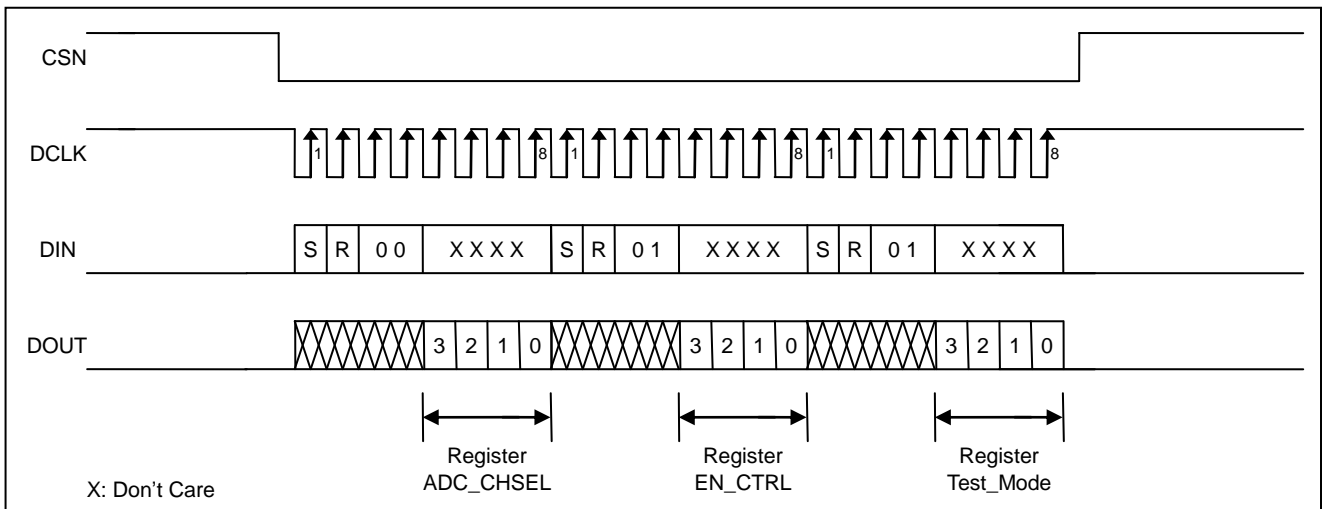

Figure 11. Control registers read-back.

5.2. Analog-to-Digital Converter

GPY0050A1 ADC is a 12-bit Successive Approximation Register (SAR) ADC. The ADC provides 12-bit / 10-bit conversion mode operation and 8 analog input channels (see Figure 12). The converter digitizes the input signal from 0V to full-scale voltage (see Figure 13). The internal applied voltage reference value determines the full-scale input voltage range. The voltage reference of the GPY0050A1 is fixed to  $V_{DD}$ .

User can operate the ADC in continuing or discontinuing conversion mode by CSN pin. In continuing conversion mode, CSN pin is always kept low. The GPY0050A1 requires 16-DCLKs per conversion (see Figure 5 & 6).

**Continuous Mode Sampling Rate =  $f_{DCLK} / 16$**

In discontinuing conversion mode, the ADC sampling and holding signal (ADC\_S/H) is controlled by CSN pin. The ADC will hold analog value on CSN falling edge, and need 24-DCLKs to complete conversion (see Figure 7 & 8). In discontinuing conversion mode, user can easily control sampling and holding time by CSN pin.

The ADC\_CHSEL register is used to select ADC input channel (IN0 ~ IN7). The IN5 ~ IN7 pins are shared with microphone preamplifier block. Therefore, the MUX cannot be set to IN5 ~ IN7 channel when microphone preamplifier is enabled. When user needs 8 channels ADC, we recommend replacing GPY0050A1 with GPY0050B.

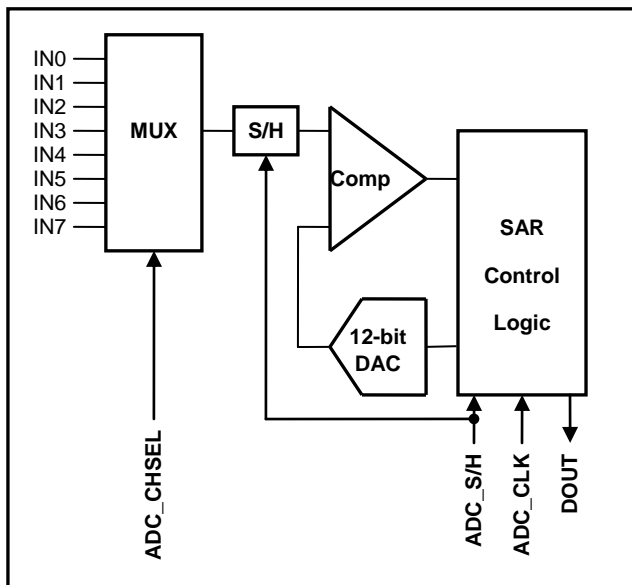

Figure 12. ADC Function Block Diagram

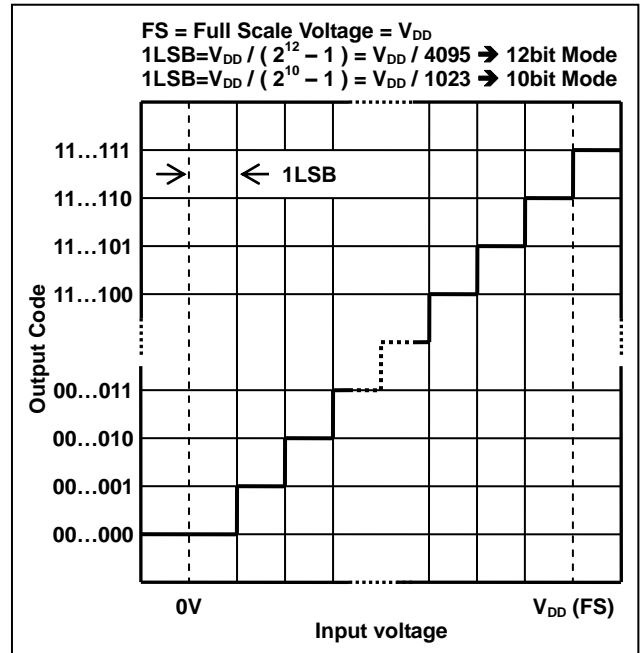

Figure 13. Ideal Input Voltage and Output Codes

5.3. ADC S/H Time

Using the input equivalent circuit in Figure 14, the capacitance charging voltage is given by:

$$V_{IN} = V_S (1 - e^{-\frac{t}{R_t \times C_{IN}}})$$

where

$$R_t = R_S + R_{IN}$$

$t_c$  = ADC S/H time

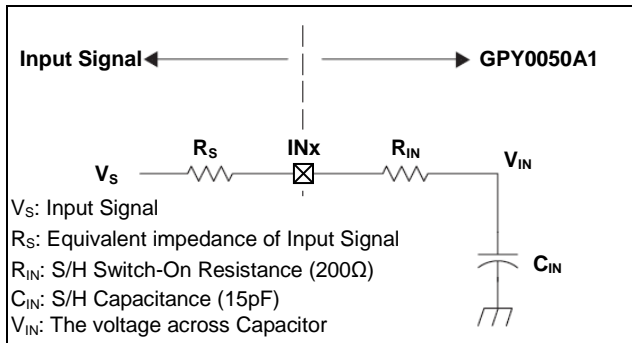

Figure 14. ADC input equivalent circuit

Then we can show in the following table the percentage voltage value for the capacitor in a RC charging circuit for a given time constant.

M x (R <sub>t</sub> x C <sub>IN</sub> ) Time Constant	V <sub>IN</sub> / V <sub>S</sub>	Error : ( 1-V <sub>IN</sub> / V <sub>S</sub> )
1 time constant	63.212%	36.78794%
3 time constants	95.021%	4.97871%
5 time constants	99.326%	0.67379%
7 time constants	99.909%	0.09119%
9 time constants	99.988%	0.01234%
10 time constants	99.995%	0.00454%
11 time constants	99.998%	0.00167%

Table 1. RC Charging Table

The Sample and Hold error must be less than LSB/2.

$$1\text{LSB} = V_{DD} / (2^N - 1)$$

$$\text{LSB}/2 \approx V_{DD} / 2^{N+1} > \text{Error} \times V_{S,\text{MAX}}$$

N = 10 → ADC 10 bits Mode

N = 12 → ADC 12 bits Mode

Error: Refer Table 1 to find the minimum time constant to meet the above conditions

$$\text{Find minimal S/H Time} \geq M \times (R_t \times C_{IN})$$

**Example: VDD=5V, V<sub>S,MAX</sub>=5V, R<sub>S</sub>=10kΩ, R<sub>IN</sub>=200Ω & C<sub>IN</sub>=15pF, ADC 12bits Mode.**

Select 10 time constants,

$$\text{LSB}/2 \approx V_{DD} / 2^{N+1} = 5 / 2^{13} = 0.61\text{mV}$$

$$\text{Error} \times V_{S,\text{MAX}} = 0.00167\% \times 5 = 0.23\text{mV} < \text{LSB} / 2$$

**The minimal S/H time must be greater than 10 time constants.**

$$10 \text{ time RC constants} = R_t \times C_{IN} = 10 \times (10\text{k} + 200) \times 15\text{p} = 1.53\mu\text{s}$$

When the ADC works in continues mode, sampling time = 3\*(1/DCLK) must be greater than or equal to 1.53us.

$$\text{Find SPI Clock DCLK} \leq 3 / 1.53\mu\text{s} = 1.96\text{MHz}$$

5.4. Microphone Preamplifier

The GPY0050A1 Microphone Preamplifier consists of several distinct circuits: microphone bias switch (M1), first stage amplifier (MIC Preamplifier), second stage amplifier (OP-Amplifier) and AGC control circuitry, shown in Figure 15.

When register EN\_MIC is set to '1', the internal switch M1 will be turned on and VMIC pin will be shorted to VDD. In order to reduce power noise, recommend RC time constant of (R<sub>VMIC</sub>×C<sub>VMIC</sub>) must be greater than 8ms and resistance of the R<sub>VMIC</sub> must be less than 2kΩ.

The first stage microphone amplifier (MIC Preamplifier) is difference input preamplifier. The gain can be varied by the AGC. When AGC pin voltage rises, the MIC preamplifier will reduce the gain. If AGC function is turned off (EN\_AGC='0'), the gain will be

set to maximum value (Gain=15 @ VDD=3.3V).

The second stage amplifier consists of R1, R2 and OPA. The default gain is (1+R2/R1) = 41. Users can make a series resistance reduce the gain of second stage amplifier.

$$\text{Gain of second stage amplifier} = 1 + R2 / (R1 + R_{OP1})$$

The AGC Control senses OPO pin output waveform. When "V<sub>OPO</sub> > VDD - 0.3" or "V<sub>OPO</sub> < 0.3", the AGC will pump C<sub>AGC</sub> capacitor. The AGC voltage will rise to reduce gain of first stage amplifier until "V<sub>OPO</sub> < VDD - 0.3" or "V<sub>OPO</sub> > 0.3". In order to avoid the noise generated by the AGC Control, recommend capacitance of the C<sub>AGC</sub> must be greater than 2.2uF and resistance of the R<sub>AGC</sub> must be greater than 470kΩ.

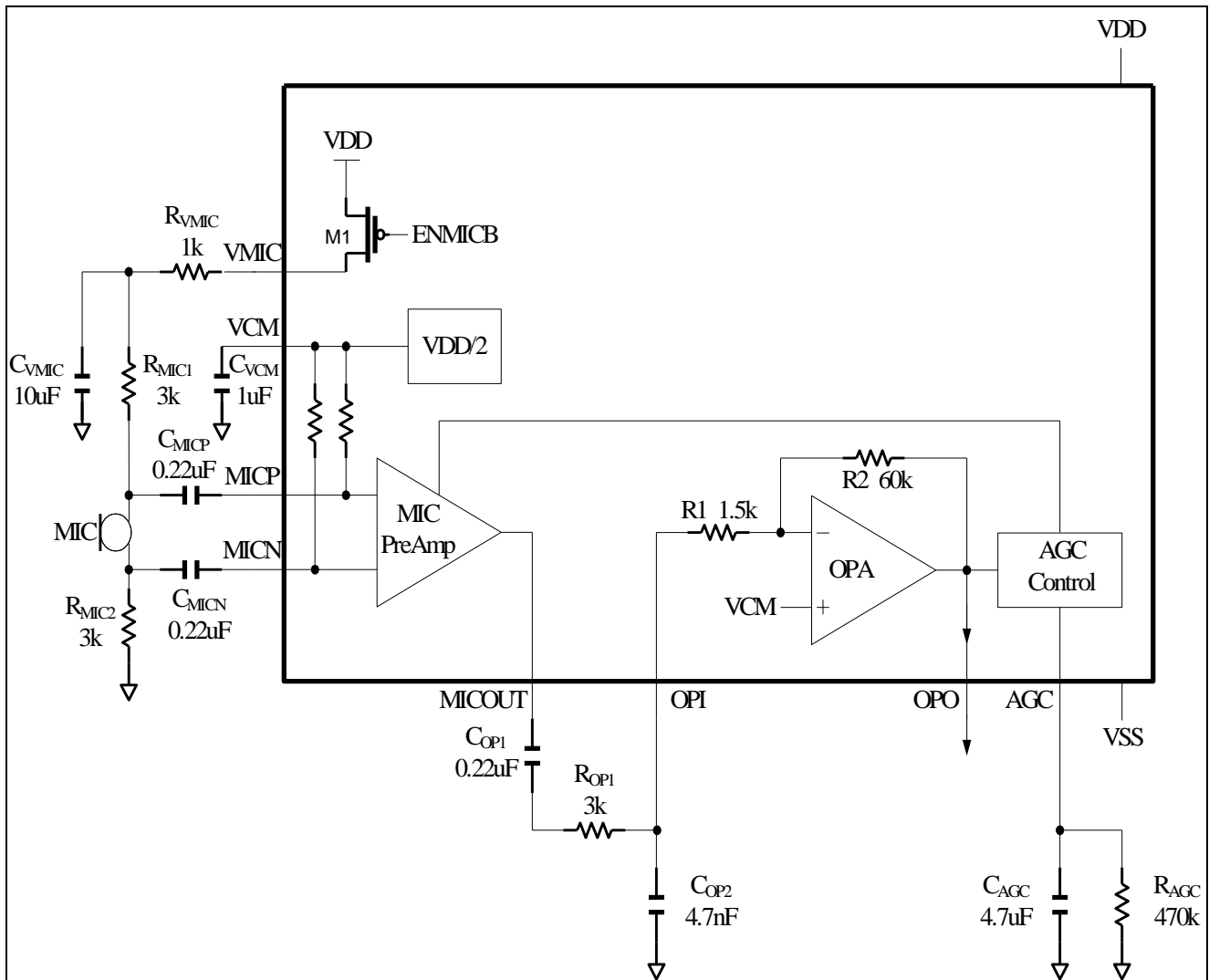

Figure 15. Microphone Preamplifier Block Diagram and Application Circuit

**6. ELECTRICAL SPECIFICATIONS**
**6.1. Absolute Maximum Ratings**

Characteristics	Symbol	Ratings
DC Supply Voltage	$V_+$	< 7.0V
Input Voltage Range	$V_{IN}$	-0.5V to $V_+ + 0.5V$
Operating free-air Temperature Range	$T_A$	0°C to + 60°C
Storage Temperature	$T_{STO}$	-50°C to + 150°C

**Note:** Stresses beyond those given in the Absolute Maximum Rating table may cause permanent damage to the device. For normal operational conditions, see AC/DC Electrical Characteristics.

**6.2. DC Characteristics ( $V_{DD}=5.0V$ ,  $T_A = 25^\circ C$ )**

Item	Test Conditions	Symbol	Min.	Typ.	Max.	Unit
Operation Voltage		$V_{DD}$	2.2	-	5.5	V
Shutdown Current		$I_{STBY}$	-	0.1	1.0	uA
Operating Current	$V_{DD} = 5.0V$	$I_{DD}$	-	2.2	3.5	mA
DCLK Frequency			-	-	2	MHz
ADC Conversion Time			-	-	16	DCLKs
ADC Acquisition Time			3	-	-	DCLKs
ADC Conversion Rate	DCLK/16	$F_{CONV}$	-	-	125	KHz
Resolution of ADC		RESO	-	-	12	bits
Signal-to-Noise Plus Distortion of ADC from Line In		SINAD	-	64	-	dB
Effective Number of Bit		ENOB	-	10.5	-	bits
Integral Non-Linearity of ADC		INL	-	±1.0	-	LSB
Differential Non-Linearity of ADC		DNL	-	±0.8	-	LSB
No Missing Code			-	12	-	bits
Microphone Input Impedance		$R_{IN}$	-	10	-	KΩ
Microphone AGC Gain	$V_{IN}=15mV\sim 300mV$ , $C_{AGC}=47uF$	Gain	6	-	40	dB
Microphone Total Harmonic Distortion	$V_{IN}=20mV$ , $f = 1.0KHz$	THD+N	-	60	-	dB



7. APPLICATION CIRCUIT

The demo board circuit of the GPY0050A1 is shown in Figure 16. User can easily evaluate GPY0050A1 performance by the demo board. In order to reduce power noise from other device, suggest connecting Power and GND Line from power source, adding power filter for the GPY0050A1 and don't share power and ground line with other devices. (See Figure 17 & 18)

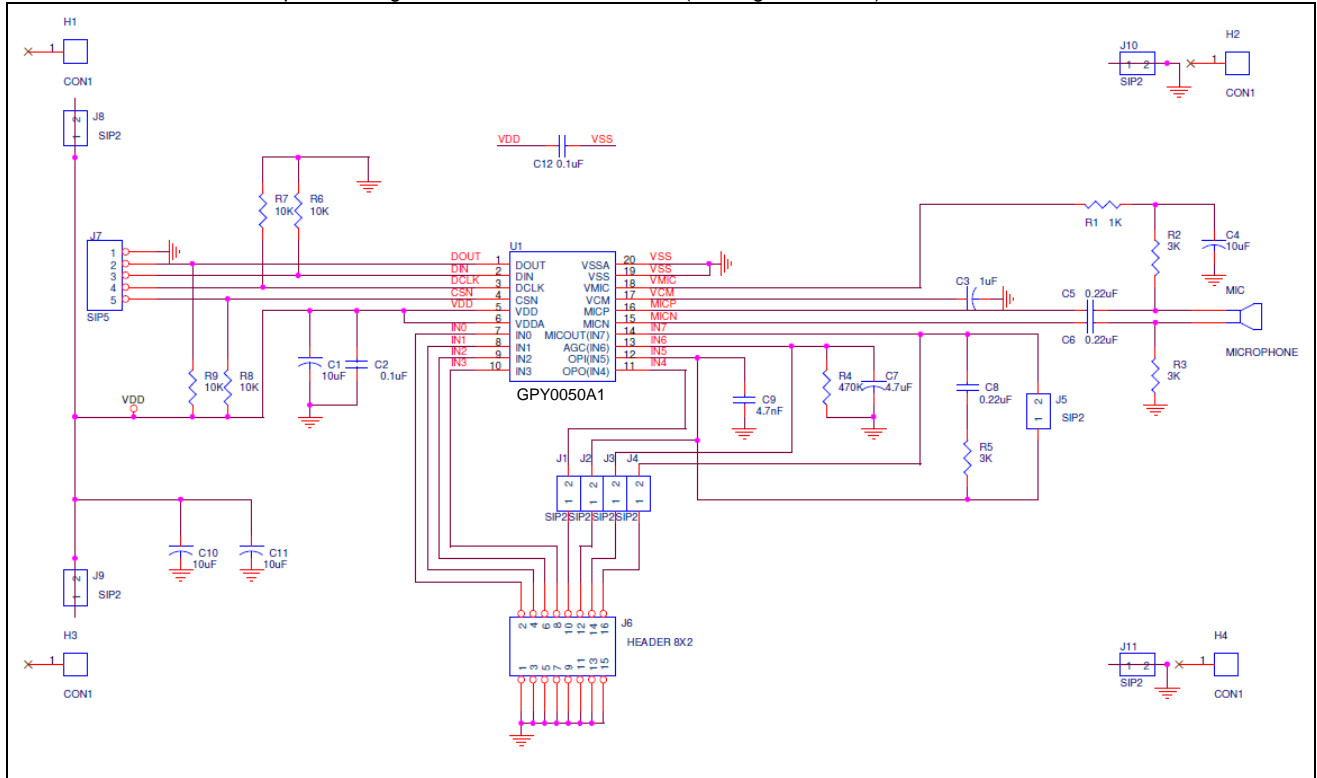

Figure 16. Demo Board Circuit of the GPY0050A1

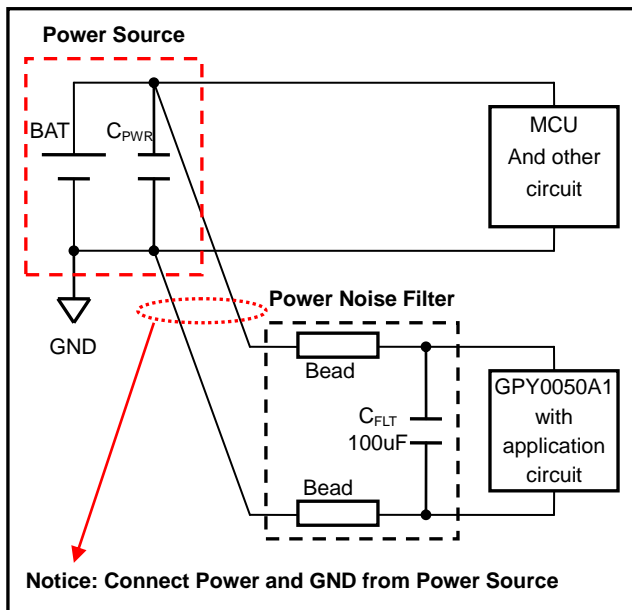

Figure 17. Application Suggestions for Reducing Power Noise

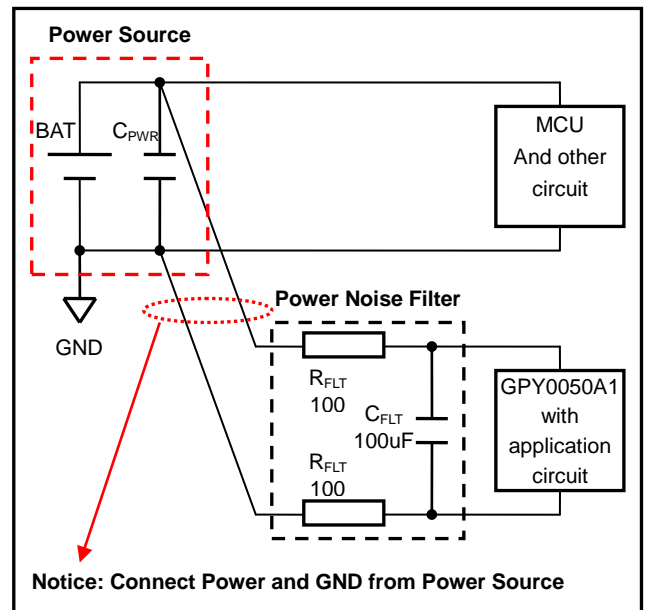
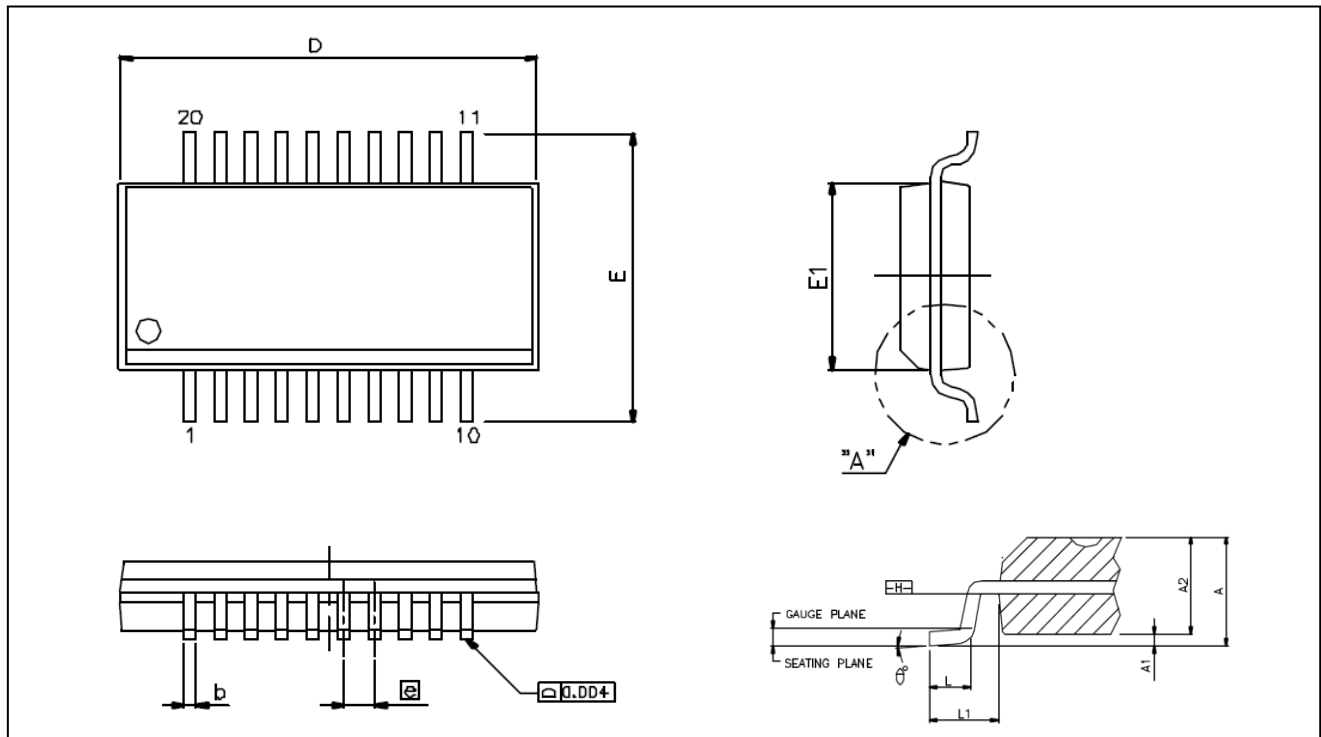

Figure 18. Application Suggestions for reducing power noise

**8. PACKAGE/PAD LOCATIONS**
**8.1. Ordering Information**

Product Number	Package Type
GPY0050A1 - C	Chip form
GPY0050A1 - HG08x	Green Package - SSOP20 (150mil)
GPY0050A1 - HG01x	Green Package - SSOP16 (150mil)
GPY0050A1 - EG08x	Green Package (Tape & Reel) - SSOP20 (150mil)
GPY0050A1 - EG01x	Green Package (Tape & Reel) - SSOP16 (150mil)

Note: Package form number (x = 1 - 9, serial number).

**8.2. Package Information**
**8.2.1. SSOP 20**

Symbol	Dimension in inch		
	Min.	Typ.	Max.
A	0.053	0.064	0.069
A1	0.004	0.006	0.010
A2	-	-	0.059
b	0.008	-	0.012
C	0.007	-	0.010
D	0.337	0.341-	0.344
E	0.291	0.236	0.244
E1	0.150	0.154	0.157
e	0.025 BASIC		
L	0.016	0.025	0.050
L1	0.014 BASIC		
$\theta^\circ$	0	-	8

8.2.2. SSOP 16

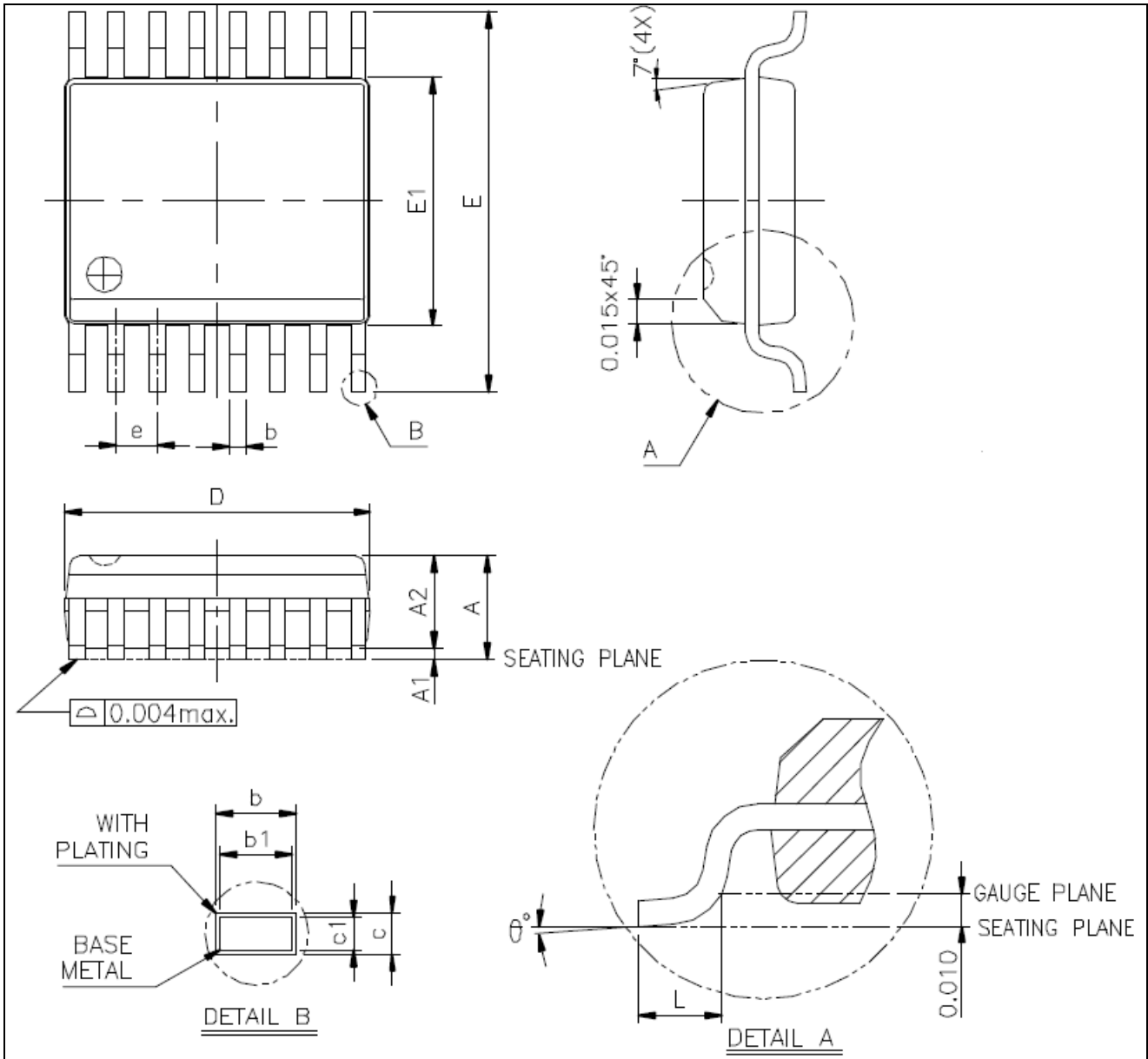

Symbol	Dimension in inch		
	Min.	Typ.	Max.
A	0.053	-	0.069
A <sub>1</sub>	0.004	-	0.010
b	0.008	-	0.012
b <sub>1</sub>	0.008	-	0.011
D	0.189	-	0.197
E	0.228	-	0.244
E <sub>1</sub>	0.150	-	0.157
L	0.016	-	0.050
e	0.025 BASIC		
$\theta^\circ$	0	-	8

---

**9. DISCLAIMER**

The information appearing in this publication is believed to be accurate.

Integrated circuits sold by Generalplus Technology are covered by the warranty and patent indemnification provisions stipulated in the terms of sale only. GENERALPLUS makes no warranty, express, statutory implied or by description regarding the information in this publication or regarding the freedom of the described chip(s) from patent infringement. FURTHERMORE, GENERALPLUS MAKES NO WARRANTY OF MERCHANTABILITY OR FITNESS FOR ANY PURPOSE. GENERALPLUS reserves the right to halt production or alter the specifications and prices at any time without notice. Accordingly, the reader is cautioned to verify that the data sheets and other information in this publication are current before placing orders. Products described herein are intended for use in normal commercial applications. Applications involving unusual environmental or reliability requirements, e.g. military equipment or medical life support equipment, are specifically not recommended without additional processing by GENERALPLUS for such applications. Please note that application circuits illustrated in this document are for reference purposes only.

**10. REVISION HISTORY**

<b>Date</b>	<b>Revision #</b>	<b>Description</b>	<b>Page</b>
Sep. 25, 2017	1.1	Modify BLOCK DIAGRAM in section 3.	3
		Modify SIGNAL DESCRIPTIONS in section 4.	4
		Modify Package Pin Assignment in section 4.2.	5
		Modify Command Mode Data Format in section 5.1.3.	7
		Add ADC S/H Time in section 5.3.	14
		Modify APPLICATION CIRCUIT in section 7.	17
Nov. 03, 2016	1.0	Modify Order Information in section 8.1.	17
JUL. 11, 2016	0.1	Original	20