

GR47/GR48 Integrator's Manual

www.DataSheet4U.com



www.DataSheet4U.com



The GR47 described in this manual conforms to the Radio and Telecommunications Terminal Equipment (R&TTE) directive 99/5/EC with requirements covering EMC directive 89/336/EEC and Low Voltage directive 73/23/EEC. The product fulfils the requirements according to 3GPP TS 51.010-1, EN 301 489-7 and EN60950.

SAR statement: This product is intended to be used with the antenna or other radiating element at least 20cm away from any part of the human body.

www.DataSheet4U.com

The information contained in this document is the proprietary information of **Sony Ericsson Mobile Communications International**. The contents are confidential and any disclosure to persons other than the officers, employees, agents or subcontractors of the owner or licensee of this document, without the prior written consent of **Sony Ericsson Mobile Communications International**, is strictly prohibited. Further, no portion of this publication may be reproduced, stored in a retrieval system, or transmitted in any form or by any means, electronic or mechanical, including photocopying and recording, without the prior written consent of **Sony Ericsson Mobile Communications International**, the copyright holder.

First edition (May 2003)

Sony Ericsson Mobile Communications International publishes this manual without making any warranty as to the content contained herein. Further **Sony Ericsson Mobile Communications International** reserves the right to make modifications, additions and deletions to this manual due to typographical errors, inaccurate information, or improvements to programs and/or equipment at any time and without notice. Such changes will, nevertheless be incorporated into new editions of this manual.

All rights reserved.

© **Sony Ericsson Mobile Communications International**, 2003

Publication number: LZT 123 7589 R1A

Printed in UK

Contents

Overview	5
1. Introduction	6
Target Users	6
Prerequisites	6
Manual Structure	6
2. GR47/GR48 Radio Devices	7
About the GR47/GR48 Family	7
Radio Devices in a Communication System	7
Features	9
Service and Support	12
Precautions	13
3. Abbreviations	14
Integrating the Radio Device	16
4. Mechanical Description	17
Interface Description	17
Physical Dimensions	18
5. System Connector Interface	19
Overview	19
General Electrical and Logical Characteristics	22
Grounds	23
VCC - Regulated Power Supply Input	23
Battery Charging Input (CHG_IN)	24
Turning the Radio Device ON/OFF and the External Power Signal	25
Analogue Audio	29
PCM Digital Audio	33
Serial Data Interfaces	36
SIM Card Related Signals	40
Service/Programming	41
Buzzer	42
LED	42
General Purpose Digital I/O Ports	43
Extended I/O capabilities	44
General Purpose Analogue I/O Ports	45
External I ² C Serial Control Bus	48
TX_ON - Burst Transmission	49

Real Time Clock.....	49
6. Antenna Connector.....	51
7. Keyboard Interface.....	52
IO#/KEYROW#.....	52
KEYCOL#.....	52
8. Hints for Integrating the Radio Device.....	54
Safety Advice and Precautions.....	54
Installation of the Radio Device.....	56
Antenna.....	58
9. Embedded Applications.....	60
Features.....	60
Implementation.....	60
10. TCP/IP Stack.....	62
Implementation.....	62
11. Technical Data.....	63
12. Declaration of Conformity.....	65

Developer's Kit 66

13. Introduction to the Developer's Kit.....	67
Contents of the Kit.....	67
General Functioning of the Kit.....	68
14. Using the Developer's Kit.....	71
Start up Check List.....	72
Developer's Board Overlay.....	73
Jumpers.....	74
Switches.....	78
Headers.....	79
Connectors.....	80
LED Indicators.....	82
System Connector Pin Assignments.....	83

Overview

1. Introduction

1.1 Target Users

www.DataSheet4U.com

The GR47 and GR48 radio devices are designed to be integrated into machine-to-machine or man-to-machine communications applications. They are intended to be used by manufacturers, system integrators, applications developers and developers of wireless communications equipment.

1.2 Prerequisites

It is assumed that the person integrating the radio device into an application has a basic understanding of the following:

- GSM networking;
- Wireless communication and antennas (aerials);
- AT commands;
- ITU-T standard V.24/V.28;
- Micro controllers and programming;
- Electronic hardware design.

1.3 Manual Structure

The manual is composed of three parts:

Part 1- Overview

This section provides a broad overview of the GR47/GR48 family and includes a list of abbreviations used in the manual.

Part 2 - Integrating the Radio Device

This section describes each of the signals available on the GR47/GR48 radio devices, along with mechanical information. The section also provides you with design guidelines and explains what is needed to commercialise an application from a regulatory point of view.

Part 3 - Developer's Kit

This section lists the contents of the Developer's Kit and provides the information to setup and use the equipment.

2. GR47/GR48 Radio Devices

2.1 About the GR47/GR48 Family

Two radio devices make up the family; GR47 and GR48, for use in the E-GSM900/GSM1800 and GSM850/GSM1900 bands respectively.

Note! This manual refers to the GR47 and GR48 as radio devices. If there is a difference in the functionality of the radio devices the GR47 and GR48 information will be listed separately.

The products belong to a new generation of Sony Ericsson radio devices, and are intended to be used in machine-to-machine applications and man-to-machine applications. They are used when there is a need to send and receive data (by SMS, CSD, HSCSD, or GPRS), and make voice calls over the GSM network.

The radio devices can either have applications embedded onto them or they can be used as the engine in an application created by the customer. The radio device can send and receive data when a script is executed, the script can be run internally from the radio device itself or from a micro-controller. A typical application, involves a micro-controller and a radio device, in which the micro-controller sends AT commands to the radio device via an RS232 communications link.

2.2 Radio Devices in a Communication System

Figures 2.1 and 2.2 illustrate the main blocks of a wireless communication system using the radio device. Figure 2.1 shows the communication system when the script is embedded on the radio device and figure 2.2 shows the communication system when a micro-controller is used. They also show the communication principles of the system and the interface between the radio device and the application. The definitions in the figures, as used elsewhere in this manual, are in accordance with the recommendations of GSM 07.07.

- The MS (mobile station) represents the radio device and SIM card. The radio device excluding SIM card, is known as the ME (mobile equipment).
- The DTE (data terminal equipment) is the controlling application. This can be either an external host or an internal embedded application.
- The DCE (data circuit terminating equipment) is the serial communication interface of the MS.

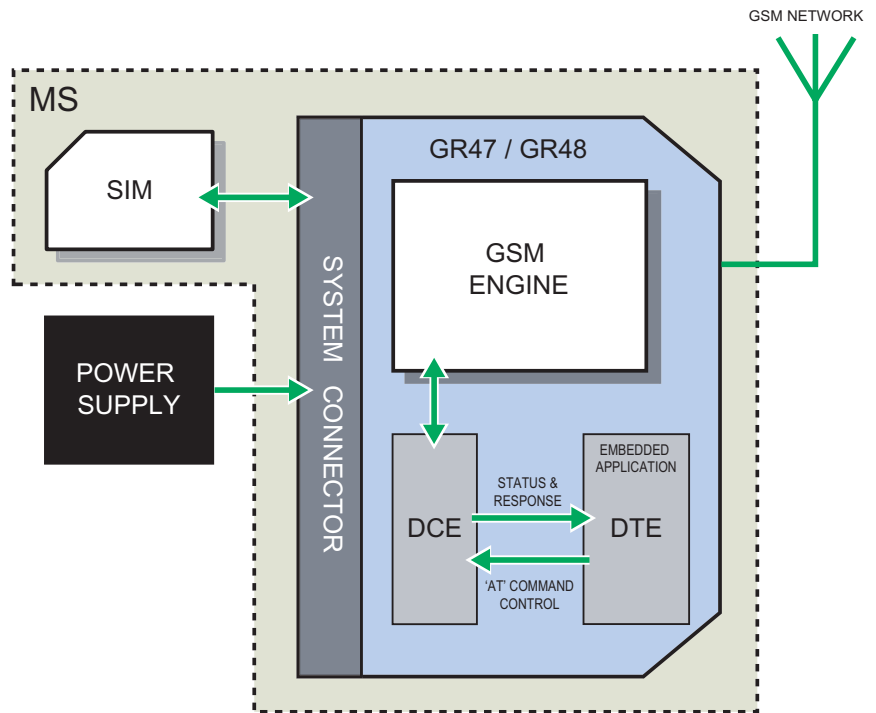

Figure 2.1 Main Blocks in a Wireless System (embedded application)

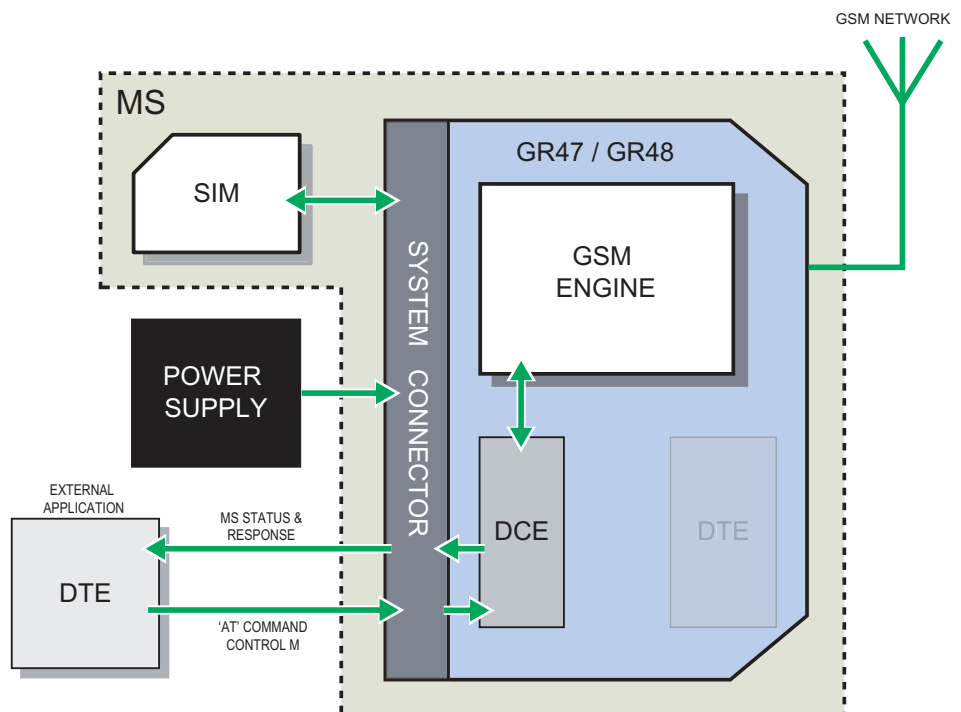

Figure 2.2 Main Blocks in a Wireless System (external micro-controller)

In accordance with the recommendations of ITU-T (International Telecommunication Union - Telecommunications Standardisation Sector) V.24, the TE communicates with the MS over a serial interface.

The functions of the radio device follow the recommendations provided by ETSI (European Telecommunications Standards Institute) and ITU-T.

ETSI specifies a set of AT commands for controlling the GSM element of the radio device; these commands are supplemented by Sony Ericsson specific commands.

To find out how to work with AT commands, see the AT Commands Manual.

www.DataSheet4U.com

2.3 Features

The radio device performs a set of telecom services (TS) according to GSM standard phase 2+, ETSI and ITU-T. The functions of the radio device are implemented by issuing AT commands over a serial interface.

2.3.1 Types of Mobile Station

GR47 and GR48 are dual band mobile stations with the characteristics shown in the tables below.

<i>GR47</i>	<i>E-GSM900</i>	<i>GSM1800</i>
Frequency Range (MHz)	TX: 880-915 RX: 925-960	TX: 1710-1785 RX: 1805-1880
Channel spacing	200kHz	200kHz
Number of channels	174 carriers *8 time slots	374 carriers *8 time slots
Modulation	GMSK	GMSK
TX phase accuracy	< 5° RMS phase error (burst)	< 5° RMS phase error (burst)
Duplex spacing	45MHz	95MHz
Receiver sensitivity at antenna connector	< -102dBm	< -102dBm
Transmitter output power at antenna connector	Class 4 2W (33dBm)	Class 1 1W (30dBm)
Automatic hand-over between E-GSM 900 and GSM 1800		
<i>GR48</i>	<i>GSM850</i>	<i>GSM1900</i>
Frequency Range (MHz)	TX: 824-849 RX: 869-894	TX: 1850-1910 RX: 1930-1990
Channel spacing	200kHz	200kHz
Number of channels	124 carriers *8 time slots	299 carriers *8 time slots
Modulation	GMSK	GMSK
TX Phase Accuracy	< 5° RMS phase error (burst)	< 5° RMS phase error (burst)

<i>GR48</i>	<i>GSM850</i>	<i>GSM1900</i>
Duplex spacing	45MHz	80MHz
Receiver sensitivity at antenna connector	< -102dBm	< -102dBm
Transmitter output power at antenna connector	Class 4 2W (33dBm)	Class 1 1W (30dBm)
Automatic hand-over between GSM850 and GSM1900		

www.DataSheet4U.com

2.3.2 Short Message Service

The radio device supports the following SMS services:

- Sending; MO (mobile-originated) with both PDU (protocol data unit) and text mode supported.
- Receiving; MT (mobile-terminated) with both PDU and text mode supported.
- CBM (cell broadcast message); a service in which a message is sent to all subscribers located in one or more specific cells in the GSM network (for example, traffic reports).
- SMS STATUS REPORT according to GSM 03.40.

The maximum length of an SMS message is 160 characters when using 7-bit encoding. For 8-bit data, the maximum length is 140 characters. The radio device supports up to six concatenated messages to extend this function. Concatenation is disabled if CNMI 3,2 is set (See the AT Commands Manual for further details).

2.3.3 Voice Calls

The radio device offers the capability of MO (mobile originated) and MT (mobile terminated) voice calls, as well as supporting emergency calls. Multi-party, call waiting and call divert features are available. Some of these features are network-operator specific.

For the inter-connection of audio, the radio device offers both single ended and balanced analogue input and output lines. Direct interface to the digital PCM (pulse code modulation) bus used within the radio device is available, thus by-passing the internal analogue circuitry.

The radio devices support HR, FR and EFR vocoders. The GR48 also supports the Adaptive Multi Rate (AMR) type of vocoder.

2.3.4 Data

The radio device supports the following data protocols:

- **GPRS (General Packet Radio Service)**
The radio devices are Class B terminals. The radio devices are GPRS 4+1 enabled, which are capable of receiving at a maximum of four timeslots per frame (down link), and transmitting in one timeslot per frame (up link).
- **CSD (Circuit Switched Data)**
The radio devices are capable of establishing a CSD communication at 9.6kbps.
- **HSCSD (High Speed Circuit Switched Data).**
The radio devices support HSCSD communication, with one timeslot per frame capacity in the up link and two timeslots per frame capacity in the down link (2+1).

2.3.5 SIM Card

An external SIM card with 3 V or 5 V technology, can be connected to the radio device via its 60-pin system connector.

2.3.6 Power Consumption

		Idle Mode	Transmit/Operation
GSM850 and E-GSM900	Voice/CSD	<5mA	<250mA (<2A peak)
	Data (GPRS 4+1)	<5mA	<350mA (<2A peak)
GSM1800 and GSM1900	Voice/CSD	<5mA	<250mA (<1.75A peak)
	Data (GPRS 4+1)	<5mA	<350mA (<1.75A peak)

Note! The power consumption during transmission is measured at maximum transmitted power.

2.3.7 Other Features

These include:

- 07.10 multiplexing.
- GPS interoperability.
- SIM application tool kit, class 2 release 96 compliant.
- Embedded application
- On board TCP/IP stack
- E-OTD (Supported by GR48)

2.4 Service and Support

2.4.1 Web Pages

Visit our web site for the following information:

- where to buy radio devices or for recommendations concerning accessories and components;
- the telephone number for customer support in your region;
- FAQs (frequently asked questions).

The web site address is:

<http://www.SonyEricsson.com/M2M>

2.4.2 Integrator's Manual

This manual provides you with all of the information you need to integrate the radio device into your application.

2.4.3 AT Commands Manual

The AT Commands Manual provides you with all the AT commands you can use with your radio device. AT commands are in logical groups and contain the command, a description of its functionality and an example of use.

2.4.4 M2mpower Application Guide

The M2mpower Application Guide provides you with all the information you need to build an application using the M2mpower support environment. This manual is supplied as part of the M2mpower package.

2.4.5 Developer's Kit

Sony Ericsson provides the developer's kit to get you started quickly. The kit includes the necessary hardware required to begin the development of an application. It includes the following:

- GSM radio device, GR47 or GR48;
- This Integrator's Manual;
- Developer's kit hardware;
- Developer's kit accessories;
 - Power supply
 - RS232 cable
 - Headset
 - Antenna.

All the user needs to provide, is a computer or micro-controller and the expertise to use AT commands.

2.5 Precautions

The radio devices are ESD protected up to 4K V contact and 8K V air discharge. It is recommended that you follow electronic device handling precautions when working with any electronic device system to ensure no damage occurs to the host or the radio device. In “Integrating the Radio Device”, page 16 you will find more information about safety and product care. Do not exceed the environmental and electrical limits as specified in “Technical Data”, page 63.

3. Abbreviations

<i>Abbreviation</i>	<i>Explanations</i>
AMR	Adaptive Multi Rate
ATMS	Audio to Mobile Station
AFMS	Audio from Mobile Station
CBM	Cell Broadcast Message
CBS	Cell Broadcast Service
CSD	Circuit Switched Data
DCE	Data Circuit Terminating Equipment
DK	Developer's Kit
DTE	Data Terminal Equipment
DTMF	Dual Tone Multi Frequency
EA	Embedded Application
EFR	Enhanced Full Rate
EMC	Electro-Magnetic Compatibility
E-OTD	Enhanced Observed Time Difference
ETSI	European Telecommunication Standards Institute
FR	Full Rate
GPRS	General Packet Radio Service
GPS	Global Positioning System
GSM	Global System for Mobile Communication
HR	Half Rate
HSCSD	High Speed Circuit Switched Data
IDE	Integrated Development Environment
IP	Internet Protocol
ITU-T	International Telecommunication Union - Telecommunications Standardisation Sector
M2mpower	Sony Ericsson's powerful support environment
ME	Mobile Equipment
MMCX	Micro Miniature Coax
MO	Mobile Originated
MS	Mobile Station
MT	Mobile Terminated
PCM	Pulse Code Modulation

3. ABBREVIATIONS

<i>Abbreviation</i>	<i>Explanations</i>
PDU	Protocol Data Unit
RF	Radio Frequency
RFU	Reserved for Future Use
RLP	Radio Link Protocol
RTC	Real Time Clock
SDP	Service Discovery Protocol
SIM	Subscriber Identity Module
SMS	Short Message Service
TCP	Transport Control Protocol
UDP	User Datagram Protocol

Integrating the Radio Device

4. Mechanical Description

4.1 Interface Description

www.DataSheet4U.com

The pictures below show the mechanical design of the radio device along with the positions of the different connectors and mounting holes. The radio device is protected with AISI 304 stainless steel covers that meet the environmental and EMC requirements.

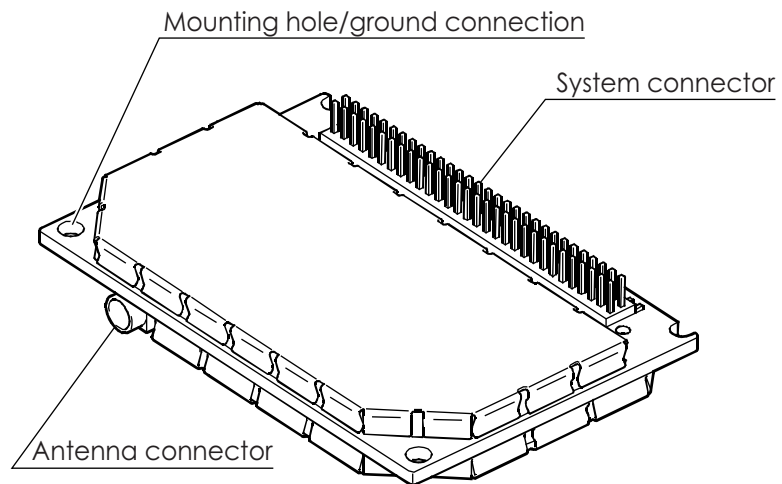

Figure 4.1 Radio Device viewed from below

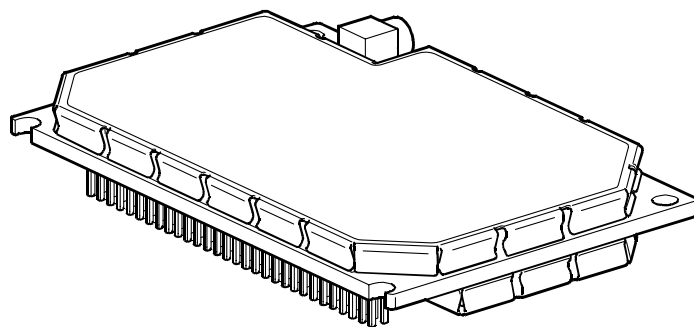

Figure 4.2 Radio Device, viewed from above

Please note the following:

- Mounting holes positioned at the corners make it possible to securely bolt the radio device into your application.

- Keypad, display, microphone, speaker and battery are not part of the radio device.
- The SIM card is mounted in your application, external to the radio device.
- The System Connector is a 60-pin, standard 0.05 in (1.27 mm) pitch type. The pins and their electrical characteristics are described in 5. System Connector Interface, page 19.
- Information about the Antenna Connector is found in 6. Antenna Connector, page 51.

www.DataSheet4U.com

4.2 Physical Dimensions

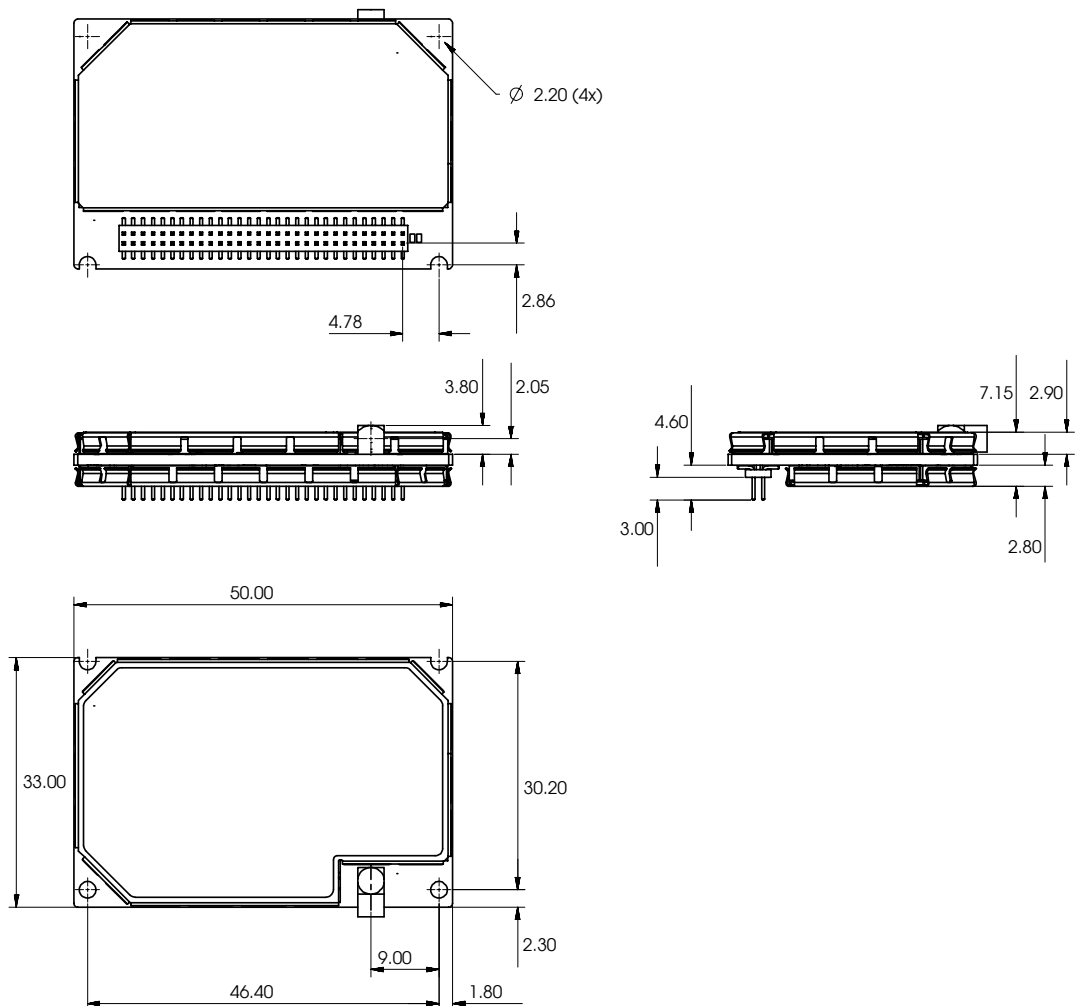

Figure 4.3 Dimensions of the Radio Device

Measurements are given in millimetres. See also Technical Data, page 63.

5. System Connector Interface

5.1 Overview

www.DataSheet4U.com

Electrical connections to the radio device (except the antenna), are made through the System Connector Interface. The system connector is a 60-pin, standard 0.05 in (1.27 mm) pitch device.

The system connector allows both board-to-board and board-to-cable connections to be made. Use a board-board connector to connect the radio device directly to a PCB, and a board-cable connector to connect the radio device via a cable.

Figure 5.1 below shows the numbering of the connector pins.

A ground connection is provided at the mounting hole next to the RF connector on the radio device as shown below. Connect this ground point to the DGND pins of the radio device by the shortest, low-impedance path possible. The purpose of this connection is to allow any antenna ESD strikes to bypass the radio device's internal ground path.

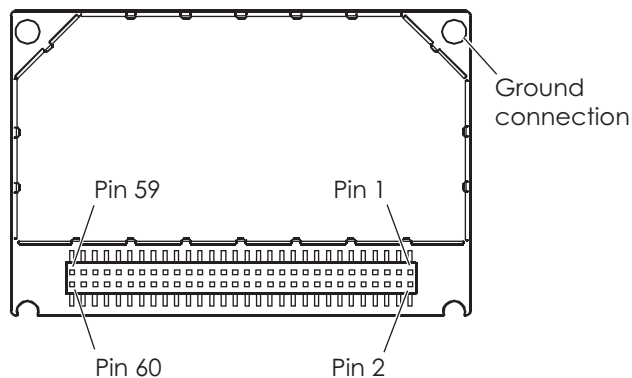

Figure 5.1 Radio Device, viewed from underneath

The following table gives the pin assignments for the system connector interface and a short description for each signal.

5. SYSTEM CONNECTOR INTERFACE

Note! Under the heading “Dir” in the table, radio device input and output signals are indicated by the letters I and O respectively.

Pin	Signal Name	Dir	Signal Type	Description
1	VCC	-	Supply	Power supply
2	DGND	-	-	Digital ground
3	VCC	-	Supply	Power supply
4	DGND	-	-	Digital ground
5	VCC	-	Supply	Power supply
6	DGND	-	-	Digital ground
7	VCC	-	Supply	Power supply
8	DGND	-	-	Digital ground
9	VCC	-	Supply	Power supply
10	DGND	-	-	Digital ground
11	CHG_IN	-	Battery charge power	Battery charging
12	DGND	-	-	Digital ground
13	IO5 ADC4	I/O I	Digital 2.75V Analogue	General purpose input/output 5 Analogue to digital converter 4
14	ON/OFF	I	Internal pull up, open drain	Turns the radio device on and off.
15	SIMVCC	-	Digital 3V/5V	SIM card power supply. Power output from radio device for SIM Card
16	SIMPRESENCE	I	Internal pull up, open drain	SIM Presence A “1” indicates that the SIM is missing; a “0” that it is inserted
17	SIMRST	O	Digital 3V/5V	SIM card reset
18	SIMDATA	I/O	Digital 3V/5V	SIM card data
19	SIMCLK	O	Digital 3V/5V	SIM card clock
20	DAC	O	Analogue	Digital to analogue converter
21	IO1 KEYROW2	I/O I	Digital 2.75V	General purpose input/output 1 Keyboard row 2
22	IO2 ADC5	I/O I	Digital 2.75V Analogue	General purpose input/output 2 Analogue to digital converter 5
23	IO3 KEYROW3	I/O I	Digital 2.75V	General purpose input/output 3 Keyboard row 3
24	IO4 KEYROW4	I/O I	Digital 2.75V	General purpose input/output 4 Keyboard row 4
25	VRTC	I	Supply 1.8V	Supply for real time clock
26	ADC1	I	Analogue	Analogue to digital converter 1
27	ADC2	I	Analogue	Analogue to digital converter 2

5. SYSTEM CONNECTOR INTERFACE

<i>Pin</i>	<i>Signal Name</i>	<i>Dir</i>	<i>Signal Type</i>	<i>Description</i>
28	ADC3	I	Analogue	Analogue to digital converter 3
29	SDA	I/O	2.75V, internal pull up	I ² C data
30	SCL	O	2.75V, internal pull up	I ² C clock
31	BUZZER	O	Digital 2.75V	Buzzer output from radio device
32	OUT3 KEYCOL3 DSR	O O O	Digital 2.75V	General purpose output 3 Keyboard column 3 Data set ready (UART1)
33	LED IO6	O I/O	Digital 2.75V	Flashing LED General purpose I/O 6
34	VIO	O	Power Out 2.75V	Radio device power indication. VIO is a 2.75V at 75mA output supply that can be used to power external circuitry that interfaces to the radio device
35	TX_ON	O	Digital 2.75V	This output indicates when the GSM radio device is going to transmit the burst
36	RI KEYCOL2 O2	O O O	Digital 2.75V	Ring Indicator (UART1) Keyboard column 2 General purpose output 2
37	DTR KEYROW1 IN1	I I I	Digital 2.75V	Data Terminal Ready (UART1) Keyboard row 1 General purpose input 1
38	DCD KEYCOL1 O1	O O O	Digital 2.75V	Data Carrier Detect (UART1) Keyboard column 1 General purpose output 1
39	RTS IO9	I I/O	Digital 2.75V	Request To Send (UART1) General purpose I/O 9
40	CTS KEYCOL4 O4	O O O	Digital 2.75V	Clear To Send (UART1) Keyboard column 4 General purpose output 4
41	TD	I	Digital 2.75V	Transmitted Data (UART1). Data from DTE (host) to DCE (radio device).
42	RD	O	Digital 2.75V	Received Data (UART1). Data from DCE (radio device) to DTE (host).
43	TD3 I/O7	I I/O	Digital 2.75V	Transmitted data (UART3) General purpose I/O 7
44	RD3 I/O8	O I/O	Digital 2.75V	Received data (UART3) General purpose I/O 8
45	TD2	I	Digital 2.75V	Transmitted data (UART2). Used for flashing the memory.
46	RD2	O	Digital 2.75V	Received data (UART2). Used for flashing the memory.
47	PCMLD	I	Digital 2.75V	DSP PCM digital audio input
48	PCMDLD	O	Digital 2.75V	DSP PCM digital audio output

<i>Pin</i>	<i>Signal Name</i>	<i>Dir</i>	<i>Signal Type</i>	<i>Description</i>
49	PCMO	O	Digital 2.75V	Codec PCM digital audio output
50	PCMI	I	Digital 2.75V	Codec PCM digital audio input
51	PCMSYNC	O	Digital 2.75V	DSP PCM frame sync
52	PCMCLK	O	Digital 2.75V	DSP PCM clock output
53	MICP	I	Analogue	Microphone Input positive
54	MICN	I	Analogue	Microphone Input negative
55	BEARP	O	Analogue	Speaker output positive
56	BEARN	O	Analogue	Speaker output negative
57	AFMS	O	Analogue	Audio output from radio device
58	SERVICE	I	2.7V	Flash programming voltage for the MS. Enable logger information if not flashing.
59	ATMS	I	Analogue	Audio input to radio device
60	AGND	-	Analogue	Analogue ground

5.2 General Electrical and Logical Characteristics

Many of the signals, as indicated in the table above, are high-speed CMOS logic inputs or outputs powered from a $2.75\text{ V} \pm 5\%$ internal voltage regulator, and are defined as Digital 2.75 V. Whenever a signal is defined as Digital 2.75 V, the following electrical characteristics apply.

<i>Parameter</i>	<i>Min.</i>	<i>Max.</i>	<i>Units</i>
High Level Output Voltage (V_{OH}), $I_o = -2\text{mA}$	2.2	2.75	V
Low Level Output Voltage (V_{OL}), $I_o = 2\text{mA}$	0	0.6	V
High Level Input Voltage (V_{IH})	1.93	2.75	V
Low Level Input voltage (V_{IL})	0	0.5	V

Note! Unused pins can be left floating.

5.2.1 General Protection Requirements

- All 2.75 V digital inputs will continuously withstand and suffer no damage in the power-on or power-off condition when subjected to any voltage from -0.5 V to 3.47 V ($3.3\text{ V} + 5\%$).
- All 2.75 V digital outputs will continuously withstand a short circuit to any other voltage within the range 0 V to 3 V .
- All analogue outputs will continuously withstand a short circuit to any voltage within the range 0 V to 3 V .

- The SIM output signals and the SIMVCC supply will continuously withstand a short circuit to any voltage within the range 0V to 4.1V.

5.3 Grounds

Pin	Signal	Description
2, 4, 6, 8, 10, 12	DGND	Digital ground
60	AGND	Analogue ground

There are two ground connections in the radio device, AGND (analogue ground) and DGND (digital ground). Pin assignments are shown in the table above.

Note! AGND and DGND are connected at a single point inside the radio device. They must *not* be joined together in your application.

5.3.1 Analogue Ground - AGND

AGND is the return signal, or analogue audio reference, for ATMS (Audio To Mobile Station) and AFMS (Audio From Mobile Station). It is connected to the DGND inside the radio device only. The application must not connect DGND and AGND.

Parameter	Limit
I_{\max}	$\cong 12.5\text{mA}$

5.3.2 Digital Ground - DGND

DGND is the reference or return signal for all system interface digital signals and is also the d.c. return for SERVICE and the power supply, VCC. Connect all DGND pins together in your application in order to carry the current drawn by the radio device.

Parameter	Per Pin	Total (5 Pins)
I_{\max}	< 6.0A	< 3.0A
I_{avg}	< 100mA	< 600mA

5.4 VCC - Regulated Power Supply Input

Pins	Signal	Description
1, 3, 5, 7, 9	VCC	regulated power supply input

Power is supplied to the radio device VCC pins, from an external source.

Connect all VCC pins together in your application in order to carry the current drawn by the radio device.

The electrical characteristics for VCC are shown in the table below.

<i>Parameter</i>	<i>Mode</i>	<i>Limit</i>
Vcc supply voltage	Nominal	3.6V
	Tolerance including ripple ^a	3.4V - 4.0V
	Over-voltage limit	5.5V
	Maximum ripple	<100mV @ <200kHz; <20mV @ >200kHz
Maximum allowable voltage drop	Burst transmission	200mV
Current drawn, at full TX power		<500mA (average)
		<2A (peak)

a. Measured at system connector pins.

Note! The radio device has no internal capacitance to supply the large current peaks during GSM burst transmission. We recommend you follow these general guidelines:

- Fit a low ESR electrolytic capacitor close to the radio device:
 - > 1,000 μ F;
 - < 100m Ω ESR.
- Make sure power supply to radio device line resistance is < 200m Ω .

5.5 Battery Charging Input (CHG_IN)

For battery powered applications, the radio device has a connection to aid and support battery charging. The typical design where this may be applicable is to power the radio device directly from a battery source connected to VCC (pins 1, 3, 5, 7, 9) and to provide a 5V dc power source (600mA max) to the CHG_IN connection (pin 11). The radio device can control an internal switching FET which creates a charging pathway to the battery. While power is provided at CHG_IN, the battery charge can be maintained. If the power should fail or be removed at CHG_IN, the application will be supported by the battery alone. When CHG_IN voltage returns, the battery charging and maintenance will commence once more.

Caution! Battery charging algorithms are unique to different battery types. Sony Ericsson Mobile Communications will not accept any responsibility or liability for damage, product failures, even death or injury occurring as a result of incompatible battery and charging algorithms being applied without their prior knowledge and consent.

Safety considerations should be taken into account. For example, monitoring the temperature of the battery. If the temperature of the battery exceeds its specification limits, battery charging must be stopped immediately. If the battery temperature continues to rise the application should be suspended or the battery disconnected.

Note! When charging Lithium batteries, the battery pack must have an internal protection circuit in accordance with the manufacturer’s instructions.

www.DataSheet4U.com

5.6 Turning the Radio Device ON/OFF and the External Power Signal

Turning the Radio Device On

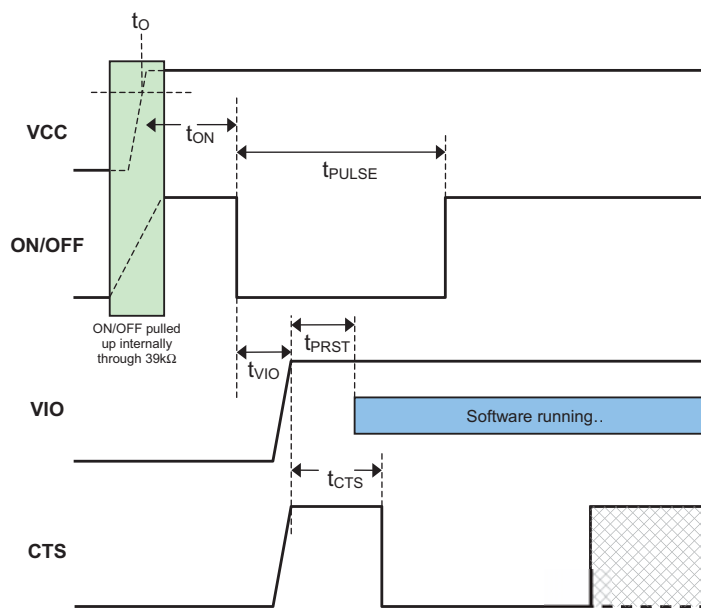

Figure 5.2 On timings and VIO performance

Symbol	Parameters	Conditions	Min.	Typ	Max	Unit
t_0	Reference time when VCC is within working limits ⁽¹⁾	VCC > 3.2V ON/OFF = VCC	-	-	-	-
t_{ON}	Time after t_0 when the ON/OFF pulse can begin	VCC > 3.2V	0	-	-	ms

5. SYSTEM CONNECTOR INTERFACE

t_{VIO}	Time after start of ON/OFF pulse when VIO is active	VCC > 3.2V	-	45.0	-	ms
t_{PULSE}	Application ON/OFF pulse width	ON/OFF held low until detected by software	400	500	-	ms
t_{PRST}	Internal Power-on reset signal initiates software		100	-	200	ms
t_{CTS}	Time when software controlled CTS signal indicates module READY	CTS signal configured for RS232 hardware flow control, not GPIO pin	-	0.35	3.0 ⁽²⁾	s

⁽¹⁾ The GR47 measures the voltage at VCC during the power-up sequence. It is important that both VCC and ON/OFF reach a minimum of 3.2V before the ON/OFF low pulse is initiated.

⁽²⁾ In SERVICE mode.

Turning the Radio Device Off

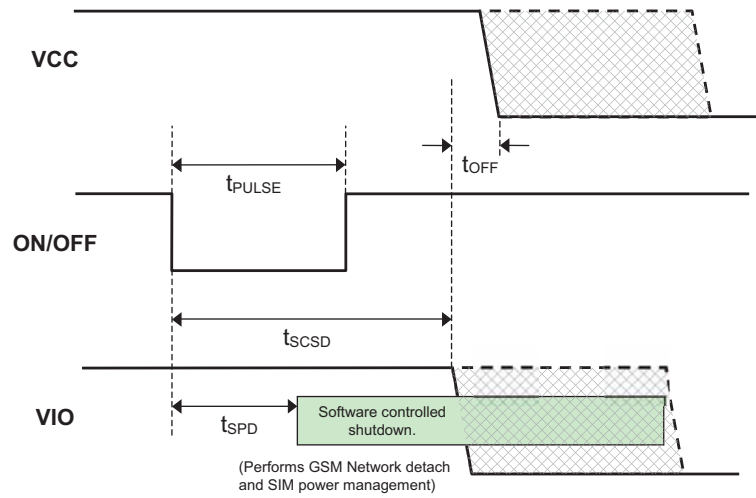
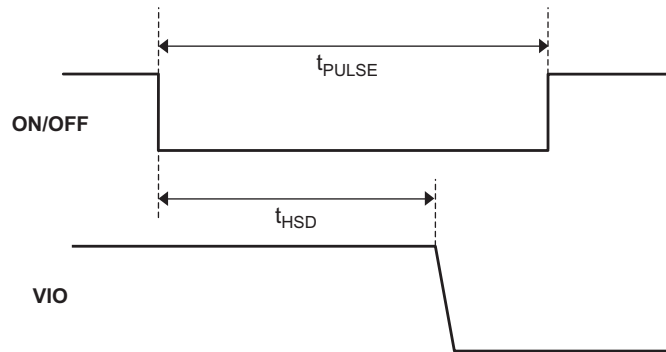

Figure 5.3 Off timings and VIO performance

Symbol	Parameters	Conditions	Min.	Typ	Max	Unit
t_{SPD}	Time for software pulse detection which initiates a software shutdown		800	-	-	ms
t_{PULSE}	Application ON/OFF pulse width		1000	-	-	ms
t_{SCSD}	Software controlled shutdown deactivates VIO (2)		-	2.5	10 ⁽³⁾	s
t_{OFF}	Time when VCC power supply can be disabled	VIO is DISABLED	0	-	-	ms

(2) It is a requirement from most GSM network providers that GSM products properly detach from the network during a power-down sequence. In order to achieve this it is important that the VCC supply is not removed or turned off before VIO has been deactivated by the module.

Hard Shutdown Sequence*Figure 5.4 Hard Shutdown Sequence*

Symbol	Parameters	Conditions	Min.	Typ	Max	Unit
t_{HSD}	Time to complete hardware shutdown		2	-	11	s
$t_{PULSE}^{(4)}$	Application ON/OFF pulse width	ON/OFF low until VIO is disabled	t_{HSD}	10	-	s

(4) To implement the Hard Shutdown of the GR47, the ON/OFF pulse must be held low until the sequence is complete. Ensure that ON/OFF is not released before VIO has been deactivated by the module.

5.6.1 VIO - 2.75V Supply

VIO provides an output voltage derived from an internal 2.75V regulator. Its electrical characteristics are shown below.

Parameter	Min.	Typ.	Max.	Units
Output Voltage ($I_{load} = 50mA$)	2.70	2.75	2.85	V
Load current			75	mA

You can use this output for the following:

- to indicate that the radio device is powered;
- to power interface circuits, external to the radio device.

5.7 Analogue Audio

<i>Pin</i>	<i>Signal</i>	<i>Dir</i>	<i>Description</i>
57	AFMS	O	Audio from mobile station
59	ATMS	I	Audio to mobile station
60	AGND	-	Ground (return) for analogue audio

ATMS is the audio input, and AFMS is the audio output, of the radio device. These signals can be used in car kit mode.

There are three factory-set audio profiles:

- portable handsfree
- handset
- car kit

Portable handsfree is the factory-set default profile. The modification, configuration, manipulation and storage of audio profiles is achieved with the AT*E2EAMS (Audio Profile Modification) and AT*E2APR (Audio Profile).

5.7.1 Audio To Mobile Station - ATMS

ATMS is the analogue audio input to the radio device. Internally, the signal is sent to the CODEC (COder/DECoder), where it is converted to digital audio in PCM (Pulse Code Modulation) format. The encoded audio is sent to PCMOOUT via the internal PCM bus.

ATMS provides a DC bias when it is used as the microphone input in Portable Hands-free applications. All other sources must be a.c.-coupled to avoid attenuation of low frequencies, and to prevent incorrect biasing or damage to the ATMS input. Use a capacitor greater than the value shown in the table below.

The ATMS input is a passive network followed by the transmit part of the CODEC.

<i>Parameter</i>	<i>Limit</i>
Application driving impedance (0.3 - 3.5kHz)	$\leq 300\Omega$
AC coupling capacitance	$\geq 1\mu\text{F}$
Radio device input impedance (0.3 - 3.5kHz)	$> 50\text{k}\Omega$
Low frequency cut-off (-3dB)	$300\text{Hz} \pm 50\text{Hz}$
High frequency cut-off (-3dB)	$> 3500\text{Hz} \pm 50\text{Hz}$
Output d.c. bias level car kit mode	0V
Additional Gain in car kit mode	28.5dB

The following tables show the nominal PGA (programming gain settings). For more information see the relevant AT commands.

Maximum input voltage limit: $245\text{ mV}_{\text{rms}}$

<i>Input</i>	<i>Input (mV_{rms})</i>	<i>TXAGC (dB)</i>	<i>AUX AMP gain</i>	<i>PCMOUT (dBm0)</i>
ATMS	245	0	13	3

Maximum input level at MICI, $61.4\text{ mV}_{\text{rms}}$ output at PCMOUT = 3 dBm0

<i>Input</i>	<i>Differential input (mV_{rms})</i>	<i>TXAGC (dB)</i>	<i>AUX AMP gain</i>	<i>PCMOUT (dBm0)</i>
MICN MICP	61.4	0	25	3

Output at AFMS for 3 dBm0 at PCMIN

<i>Input</i>	<i>dBm0</i>	<i>RXPGA</i>	<i>Volume control (dB)</i>	<i>AFMS (mV_{rms})</i>
PCMIN	3	0	0	436

Output at BEARN/BEARP for 3 dBm0 at PCMIN

<i>Input</i>	<i>dBm0</i>	<i>RXPGA</i>	<i>Volume control (dB)</i>	<i>BEAR (mV_{rms})</i>
PCMIN	3	0	0	388

5.7.2 Audio From Mobile Station - AFMS

AFMS is the analogue audio output from the radio device and may be used to drive a speaker or the ear-piece in a car kit.

PCM digital audio signals, entering the radio device through the PCMIN pin, are translated to analogue signals by the CODEC. See 5.8 PCM Digital Audio, page 33 for further information.

The table below shows the audio signal levels for AFMS.

<i>Parameter</i>	<i>Limit</i>
Speaker impedance	64Ω to 1 kΩ

Parameter	Limit	
Output Capacitance	2.2µF ±10%	
Levels (THD <5%)	Drive capability into 5kΩ (0.3 - 3.5kHz)	>2.4V _{p-p}
	Drive capability into 1.5kΩ (0.3 - 3.5kHz)	>2.2V _{p-p}
	Drive capability into 150Ω (at 1 kHz)	>1.3V _{p-p}

www.DataSheet4U.com

5.7.3 Microphone Signals

Pin	Speaker signals	Dir	Function
53	MICP	I	Microphone positive input
54	MICN	I	Microphone negative input

MICP and MICN are balanced differential microphone input pins. These inputs are compatible with an electret microphone. The microphone contains an FET buffer with an open drain output, which is supplied with at least +2 V relative to ground by the radio device as shown below.

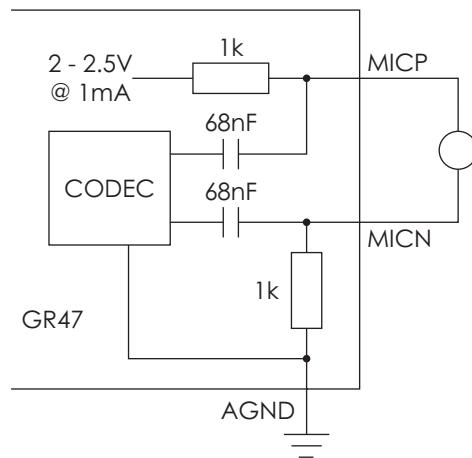

Figure 5.5 Microphone connections to the radio device

5.7.4 Speaker Signals

<i>Pin</i>	<i>Speaker signals</i>	<i>Dir</i>	<i>Function</i>
55	BEARP	○	Speaker positive output
56	BEARN	○	Speaker negative output

BEARP and BEARN are the speaker output pins. These are differential-mode outputs. The electrical characteristics are given in the table below.

<i>Parameter</i>	<i>Limit</i>
Output level (differential)	$\geq 4.0V_{pp}$
Output level (dynamic load = 32Ω)	$\geq 2.8V_{pp}$
Gain PCMIN ⁽⁵⁾ to BEARP/BEARN (differential)	$-9dB \pm 1$
Distortion at 1 kHz and maximum output level	$\leq 5\%$
Offset, BEARP to BEARN	$\pm 30mV$
Ear-piece mute-switch attenuation	$\geq 40dB$

⁽⁵⁾ See PCMIN signal in 5.8 PCM Digital Audio, page 33.

The following table shows the ear piece impedances that can be connected to BEARP and BEARN.

<i>Ear piece model</i>	<i>Impedance</i>	<i>Tolerance</i>
Dynamic ear piece	$(32\Omega + 800\mu H) // 100pF$	$\pm 20\%$
Dynamic ear piece	$(150\Omega + 800\mu H) // 100pF$	$\pm 20\%$
Piezo ear piece	$1k\Omega + 60nF$	$\pm 20\%$

5.8 PCM Digital Audio

Pin	Signal	Dir	Function
52	PCMCLK	O	PCM clock
51	PCMSYNC	O	PCM frame sync
47	PCMULTD	I	PCM audio input to DSP
48	PCMDLD	O	PCM audio output from DSP
50	PCMIN	I	PCM audio input to Codec
49	PCMOUT	O	PCM audio output to Codec

Figure 5.6 shows the PCM (Pulse Code Modulation) digital audio connection for external devices. These connections can be used to process PCM digital audio signals, bypassing the radio device's internal analogue audio CODEC.

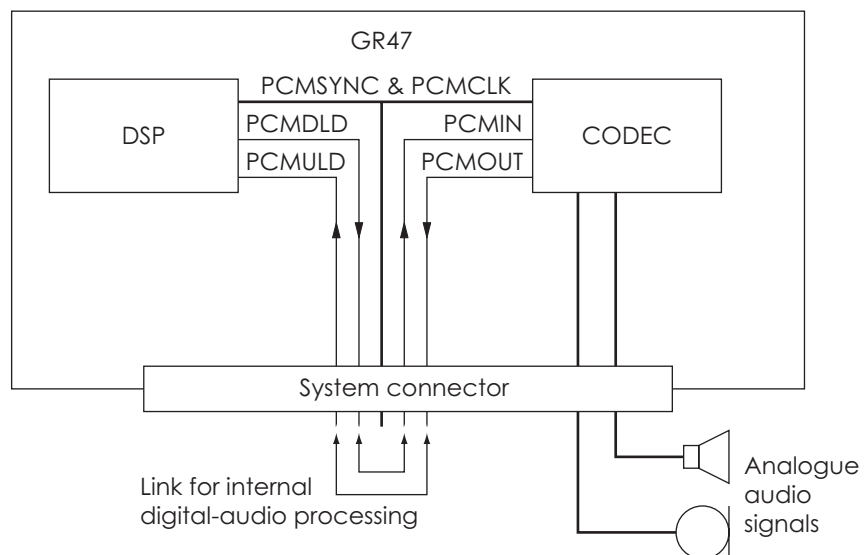

Figure 5.6 Pin connections to digital audio

Note! When no external audio processing is performed, the following pins must be connected together:

- PCMDLD to PCMIN
- PCMULTD to PCMOUT

Electrical characteristics

Digital 2.75 V CMOS input/output electrical characteristics apply.

5.8.1 PCM Data Format

All of the radio device's PCM signals, including signals between its CODEC and DSP conform to the PCM data I/O format of the industry standard DSP from Texas Instruments.

PCMCLK (bit clock) and PCMSYNC (frame synchronisation) are both generated by the DSP within the radio device.

The DSP within the radio device is the master therefore all external PCM clocks and data from external devices must be synchronized to it

13-Bit PCM Mode

Bit	Contents
D15 to D14	Equal to D13
D13 to D1	Two's complement of the 13-bit PCM
D0	LSB, not used

The radio device implements 13-bit PCM with the 13-bit data embedded in a 16-bit word within a 24-bit frame (see Figure 5.8). Each PCM word contains 16-bits: D0 to D15. D13 to D1 is the two's complement value of the 13-bit PCM, with D13 as the sign bit. D14 and D15 are always set to be equivalent with D13. D0, the LSB, is not used as shown in Figure 5.7 below.

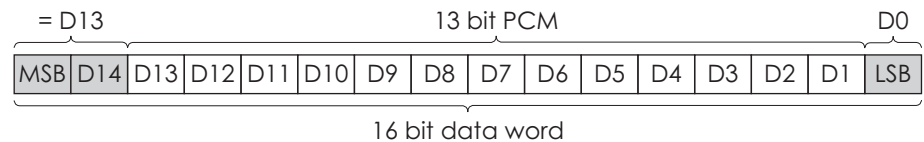

Figure 5.7 16-bit data word format

16-Bit PCM Mode

Bit	Contents
D15 - D0	Two's complement

The frame format is equal to the one shown in Figure 5.7, but with D15, D14 and D0 filled with significant bits. D15 to D0 is the two's complement value of the 16-bit PCM with bit 15 as the sign bit.

PCM Timing Diagrams

The PCM timing is shown in Figure 5.8 below and it is seen that the CPU has $45\ \mu\text{s}$ to serve an interrupt and setup data channels. Data is sent on the falling edge of the sync pulse. The data bits in PCMULD and PCMDLD are aligned so that the MSB in each word occurs on the same clock edge as shown in Figure 5.9.

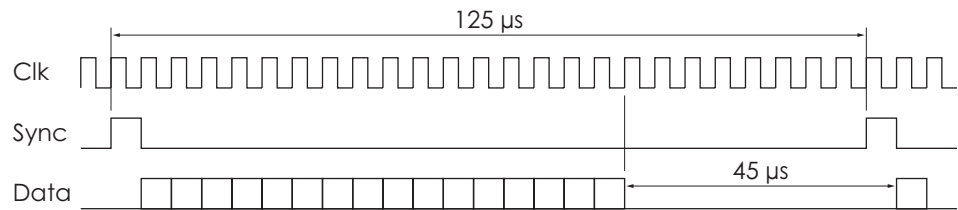

Figure 5.8 16-bit word within 24-bit frame

PCM signal timing is shown in Figure 5.9. The signals characteristics are described in the tables following Figure 5.9.

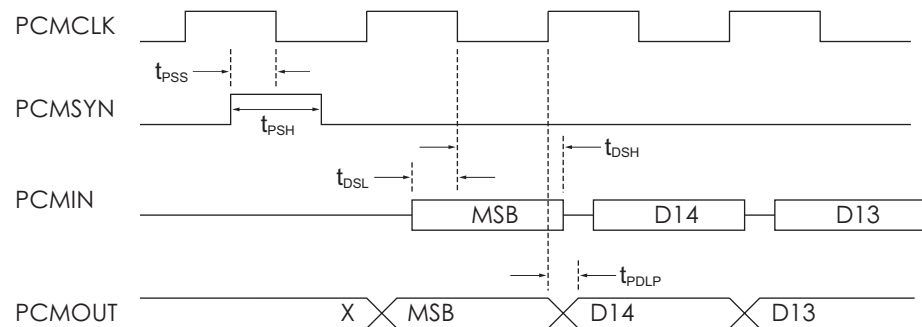

Figure 5.9 PCM Timing Diagram

Name	Description	Typ.	Unit
t_{PSS}	PCMSYN (setup) to PCMCLK (fall)	2.5	μs
t_{PSH}	PCMSYN pulse length	5	μs
t_{DSL}	PCMI (setup) to PCMCLK (fall)	2.5	μs
t_{DSH}	PCMI (hold) from PCMCLK (fall)	2.5	μs
t_{PDLP}	PCMO valid from PCMCLK (rise)	2.5	μs
Name	Description	Typ.	Unit
F_{PCMCLK}	PCM clock frequency	200	kHz
T_{PCMCLK}	PCM clock period with 50/50 mark space ratio	5	μs
F_{PCMSYN}	PCM sync frequency	8	kHz

<i>Typical Rise/Fall times</i>	<i>Rise Time</i>	<i>Fall Time</i>	<i>Unit</i>
PCMCLK	19	18	ns
PCMSYN	19	15	ns
PCMOUT	900	900	ns
PCMDLD	20	19	ns

5.9 Serial Data Interfaces

<i>Pin</i>	<i>Signal</i>	<i>Dir</i>	<i>Description</i>	<i>RS232 CCITT N°</i>
41	TD	I	Serial data to radio device (UART1)	103
42	RD	O	Serial data from radio device (UART1)	104
39	RTS IO9	I I/O	Request To Send (UART1) General purpose input/output 9	105
40	CTS KeyCOL4 O4	O O O	Clear To Send (UART1) Key column 4 General purpose output 4	106
37	DTR KeyROW1 IN1	I I	Data Terminal Ready (UART1) Keyboard row 1 General purpose input 1	108.2
32	DSR KeyCOL3 O3	O O O	Data Set Ready (UART) Key column 3 General purpose output 3	107
38	DCD KeyCOL 1 O1	O O O	Data Carrier Detect (UART1) Key column 1 General purpose output 1	109
36	RI KeyCOL 2 O2	O O O	Ring Indicator (UART1) Key Column 2 General output 2	125
45	TD2	I	Transmitted Data (UART2)	
46	RD2	O	Received Data (UART2)	
43	TD3	I	Transmitted Data (UART3)	
44	RD3	O	Received Data (UART3)	

The serial channels, consisting of three UARTs, are asynchronous communication links to the application or accessory units.

- UART1 has RS-232 functionality and is used for all on- and off -line communication.
- UART2 behaves as a general-purpose serial data link. For example, it can be used for GPS, downloading software and receiving logging information.
- UART3 behaves as a general-purpose serial data link. It can be used by an embedded application.

Digital 2.75 V CMOS input/output electrical characteristics apply.

The standard character format consists of 1 start bit, 8 bit data, no parity and 1 stop bit. In all, there are 10 bits per character.

5.9.1 UART1 (RS232) - RD, TD, RTS, CTS, DTR, DSR, DCD and RI

UART1 signals conform to a 9-pin RS232 (V.24) serial port.

Note!

UART1 signal levels do not match standard RS232 (V.28) levels. The relationship between the levels is shown in the table below.

RS232 level	RD, TD	RTS, CTS, DTR, DSR, DCD, RI	CMOS level
<-3V	1	OFF	>1.93V
>+3V	0	ON	<0.80V

Conversion between the radio device CMOS levels and RS232 levels can be achieved using a standard interface IC, such as the Maxim Integrated Products MAX3237.

5.9.2 Serial Data Signals - RD, TD

The default baud rate is 9.6kbits/s, however higher bit rates of up to 460 kbits/s are supported, set by an AT command. UART1 starts at a rate of 9.6kbits/s in standard AT command mode. The radio device also supports GSM 07.10 multiplexing protocol and starts when the appropriate command is sent.

Serial Data From Radio Device (RD)

RD is an output signal that the radio device uses to send data via UART1 to the application.

Parameter	Limit
Application load resistance	<100k Ω
Application load capacitance	<100pF

Serial Data To Radio Device (TD)

TD is an input signal, used by the application to send data via UART1 to the radio device.

Parameter	Limit
Application driving impedance	<100 Ω
Input capacitance	1nF
Input resistance	100k Ω to 2.75 V

5.9.3 Control Signals - RTS, CTS, DTR, DSR, DCD, RI

UART1 control signals are active low and need a standard interface IC, such as the MAX3237, to generate standard RS232 levels.

UART1 converted signals, together with DGND, RD and TD form a 9-pin RS232 data port.

RTS and CTS are capable of transmitting at $1/10^{\text{th}}$ of the data transmission speed for data rates up to 460kbit/s (byte-oriented flow control mechanism).

Note! When hardware flow control is not used in communications between the application and the radio device, RTS and CTS must be connected to each other at the radio device.

Switching times for RTS and CTS

The table below shows the switching times.

Parameter	Limit
Time from Low to High level	<2 μ s
Time from High to Low level	<2 μ s

Request to Send (RTS)

Used to condition the DCE for data transmission. The default level is high by internal pull up.

The application must pull RTS low to enable data transmission from the radio device. Similarly, the radio device asserts CTS low, indicating it is ready to receive data transmission from the host.

Parameter	Limit
Application driving impedance	<100 Ω
Input capacitance	<2nF
Input resistance (pull-up)	100k Ω to DGND

Clear To Send (CTS)

CTS is asserted by the DCE to indicate that the host (DTE) may transmit data. When CTS is high, the host (DTE) is not permitted to transmit data.

The table below shows the load characteristics for this signal.

Parameter	Limit
Application load capacitance	<500pF
Application load resistance	\geq 1M Ω

Data Terminal Ready (DTR)

DTR indicates that the DTE is ready to receive data. It also acts as a hardware 'hang-up', terminating calls when switched high. The signal is active low. You can define the exact behaviour of DTR with an AT command.

Data Set Ready (DSR)

DSR indicates that the DCE is ready to receive data. The signal is active low.

Data Carrier Detect (DCD)

DCD indicates that the DCE is receiving a valid carrier (data signal) when low.

Ring Indicator (RI)

RI indicates that a ringing signal is being received by the DCE when low. You can define the exact behaviour of RI with an AT command.

5.9.4 UART2 - TD2, RD2

UART 2 consists of a full duplex serial communication port with transmission and reception lines.

This communication port works in a mode called Operation and Maintenance.

Operation and Maintenance mode works in combination with the SERVICE signal. Two events are possible if the SERVICE signal is active when the radio device is turned on. These are:

- the radio device is reprogrammed if UART2 is connected to a computer running Sony Ericsson update software;
- the radio device enters logging mode and sends data to UART2 if no reprogramming information is received.

Timing and electrical signals characteristics are the same as for UART1, TD and RD, except for maximum baud rate which could increase to 921 kbps.

Transmitted Data 2 (TD2)

TD2 is used by the application to send data to the radio device via UART2. It has the same electrical characteristics as TD.

Received Data 2 (RD2)

RD2 is used to send data to the application via UART2. It has the same electrical characteristics as RD.

5.9.5 UART3 - TD3, RD3

UART3 is a full duplex serial communication port with transmission and reception lines. It has the same timing and electrical signal characteristics as UART1, TD and RD.

Transmitted Data 3 (TD3)

TD3 is used by your application to send data to the radio device via UART3.

Received Data 3 (RD3)

RD3 is used to send data to your application via UART3.

5.10 SIM Card Related Signals

<i>Pin</i>	<i>Signal</i>	<i>Dir</i>	<i>Description</i>
15	SIMVCC	-	SIM card power supply
16	SIMPRESENCE	I	SIM card presence
17	SIMRST	O	SIM card reset
19	SIMCLK	O	SIM card clock
18	SIMDATA	I/O	SIM card data

These connections allow you to communicate with the SIM card holder in your application.

Note!

The distance between the SIM card holder and the radio device can be up to 25cm.

This SIM interface allows the use of 3 V and 5 V SIM cards. By default it works on 3 V levels but will automatically switch to 5 V, if a 5 V SIM card is fitted.

SIM voltage levels, as shown in the following table, are dependent on the type of SIM card detected by the radio device.

<i>Signal</i>	<i>Parameter</i>	<i>Mode</i>	<i>Min.</i>	<i>Typ.</i>	<i>Max.</i>	<i>Unit</i>
SIMVCC	SIM supply voltage	3V	2.7	3.0	3.3	V
		5V	4.5	5.0	5.5	V
SIMDAT	High Level Input voltage (V_{IH})	3V	2.1		3.0	V
		5V	3.5		5.0	V
SIMDAT	Low Level Input voltage (V_{IL})	3V	0		0.9	V
		5V	0		1.5	V

Signal	Parameter	Mode	Min.	Typ.	Max.	Unit
SIMDAT	High Level Output voltage (V_{OH})	3V	2.7		3.0	V
		5V	4.7		5.0	V
SIMDAT	Low Level Output voltage (V_{OL})	3V	0		0.2	V
		5V	0		0.2	V
SIMCLK SIMRST	High Level Output voltage (V_{OH})	3V	2.4		3.0	V
		5V	4.4		5.0	V
SIMCLK SIMRST	Low Level Output voltage (V_{OL})	3V	0		0.35	V
		5V	0		0.3	V

5.10.1 SIM Detection - SIMPRESENCE

SIMPRESENCE is used to determine whether a SIM card has been inserted into or removed from the SIM card holder. You should normally wire it to the “card inserted switch” of the SIM card holder, but different implementations are possible.

When left open, an internal pull-up resistor maintains the signal high and means “SIM card missing” to the radio device. When pulled low the radio device assumes a SIM card is inserted.

SIMPRESENCE is a Digital 2.75V CMOS input with the following electrical characteristics.

Parameter	Min.	Typ.	Max.	Units
Pull-up resistance (at 2.75 V)	100			k Ω
Low Level Input voltage (SIM inserted)			0.80	V
High Level Input voltage (SIM missing)	>1.93		2.75	V

Note! To meet regulatory approvals SIMPRESENCE must be implemented.

5.11 Service/Programming

Pin	Signal	Dir	Description
58	SERVICE	I	Flash programming voltage

When the SERVICE input signal is active the radio device will:

- be reprogrammed if data is received through UART2 from a computer running Sony Ericsson reprogramming software;
- or it will output logging data on UART2.

The electrical characteristics are given below. The signal reference is DGND.

Mode	SERVICE Voltage (V)			Drive Capacity
	Min.	Typ.	Max.	
Normal Operation			0.8	-
Service/enable programming	1.9	2.75V	3.6	>1mA
Absolute maximum voltage			13.5	

www.DataSheet4U.com

5.12 Buzzer

Pin	Signal	Dir	Description
31	BUZZER	O	Buzzer output from radio device

Connecting the BUZZER signal to an inverting transistor-buffer followed by a piezoelectric transducer enables the radio device to play pre-programmed melodies or sounds.

5.13 LED

Pin	Signal	Dir	Description
33	LED	O	LED Output from radio device

The LED states shown below, are hard coded.

LED indication	Operational status
No indication	No power or in the OFF state
Green, steady	Power on, not connected to a network
Green, blinking	Power on, connected to a network

The following circuit can be used to connect an LED.

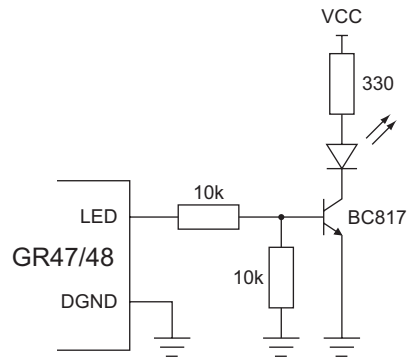

Figure 5.10 Electrical connections for the LED

5.14 General Purpose Digital I/O Ports

Pin	I/O port signal	Default signal	Description
21	IO1	IO1	Programmable Input/Output 1 KEYRow2
22	IO2	IO2	Programmable Input/Output 2 ADC5
23	IO3	IO3	Programmable Input/Output 3 KEYRow3
24	IO4	IO4	Programmable Input/Output 4 KEYRow4
13	IO5	IO5	Programmable Input/Output 5 ADC4
33	IO6	LED	Programmable Input/Output 6/LED
43	IO7	TD3	Programmable Input/Output 7/TD3
44	IO8	RD3	Programmable Input/Output 8/RD3
39	IO9	RTS	Programmable Input/Output 9/RTS
37	IN1	DTR	Programmable Input 1 Data Terminal Ready
32	OUT3	DSR	Programmable Output 3/DSR
36	OUT2	RI	Programmable Output 2/RI Ring Indicator
38	OUT1	DCD	Programmable Output 1/DCD Data Carrier Detect
40	OUT4	CTS	Programmable Input/Output 4/CTS

Signals which have an entry in the Default Signal column in the above table are multiplexed.

The operational modes of multiplexed signals are controlled by AT commands and also by intrinsic functions available to an embedded

The following table gives you the input impedance. These values only apply when the ports are configured as input signals.

<i>Parameter</i>	<i>Min.</i>	<i>Typ.</i>	<i>Max.</i>	<i>Units</i>
Input impedance (pull-up)	50	100	120	k Ω

Notes! I/O6 (LED) doesn't have an internal pull up. If this pin is configured as an input, it should not be left floating.
I/O7 (TD3) has a pull down instead of a pull up.

5.15 Extended I/O capabilities

To increase flexibility and variety of radio device peripherals, the RS232 hardware flow control shares its physical interface with the keypad scanning interface and the extended general purpose I/O capability. This sharing means that it is not feasible to operate all these features concurrently, however, with care, dynamic switching from one feature to another is possible.

Using Embedded Applications

When a particular I/O feature is required, the user sets the state of the relevant I/O blocks by disabling one set before enabling others.

The radio device checks the state of the I/O when the user requests a new function. The new function is rejected if the current function is not released first.

Note! Only the states of I/O1 - I/O5 are retained for the next power up. For example, inputs remain as inputs and outputs remain as outputs. The voltage of a defined output pin will still drop to 0 Volts in the radio device power down state.

5.15.1 LED/I/O6 Capabilities

The LED function pin can be used as a general purpose digital I/O when the flashing LED function is not required. However, this pin does not have an on-board pull-up resistor. It is required that an external pull-up or pull-down resistor be provided by the host circuitry when either not used or when used as a digital input.

5.15.2 I#/O#

If pins labelled I# and O# are not being used for an alternative function they may be used for general purpose inputs or outputs respectively. The inputs have an on-board 100k pull-up resistor and the outputs are driven rail-to-rail at 2.75V levels.

5.15.3 UART3/IO#

www.DataSheet4U.com

The UART3 pins have been given alternative functions as general purpose I/O, both pins may be used for either input or output. However, the TX pin has a 100kΩ pull-down resistor to ground and the RX pin has a 100kΩ pull-up resistor to 2.75V. This must be taken into consideration when designing the host circuit.

5.15.4 IO#/ADC#

To increase analog input capabilities, the radio device optimises the I/O by multiplexing or sharing different features on single pins. There are two digital I/O pins which now have an additional ADC input. When configured as digital I/O, the software will not read the voltages at the two new ADC inputs. When configured as ADC inputs the software will configure the digital I/O pins as input or high impedance tri-state. In this state any applied voltage between 0V and 2.75V can be read as an 8 bit value.

Because the additional ADC inputs (ADC4 and ADC5) are common with digital I/O, the input circuit of the ADC is not the same as for the original circuits ADC1-3. It is important to understand the input structure of the pin so that the correct analog voltage is read by the application.

5.16 General Purpose Analogue I/O Ports

<i>Pin</i>	<i>Signal</i>	<i>Dir</i>	<i>Description</i>
20	DAC	O	Digital to analogue conversion output
26	ADC1	I	Analogue to digital conversion input 1
27	ADC2	I	Analogue to digital conversion input 2
28	ADC3	I	Analogue to digital conversion input 3
13	ADC4 (I/O5)	I (I/O)	Analogue to digital conversion input 4
22	ADC5 (I/O2)	I (I/O)	Analogue to digital conversion input 5

The radio device is able to convert digital to analogue signals and vice versa.

5.16.1 Digital to Analogue Converter - DAC

The DAC is an 8-bit converter. Conversion takes place when an AT command is sent to the radio device. The radio device sends the resulting analogue value to the DAC pin.

Tolerance on this internal voltage is $\pm 5\%$

DAC output electrical characteristics are given in the following table.

Parameter	Limit	Units
Resolution	8	Bits
Output voltage for code = 0	$(2.75^{(6)} \times 0.05) \pm 0.05$	V
Output voltage for code = 255	$(2.75^{(6)} \times 0.95) \pm 0.05$	V
Nominal step size	$(2.75^{(6)} \times 0.9)/256$	mV
Absolute error ⁽⁷⁾	$\leq \pm 0.5$	mV
Output wide-band noise and clock feed-through 0-1.1 MHz	≤ 0.5	mV _{rms}
Power-supply rejection ratio 50Hz - 10kHz	≥ 40	dB
Conversion rate ± 0.5 LSB	≤ 2 (Load A) ⁽⁸⁾	ms
	≤ 50 (Load B) ⁽⁸⁾	ms
Output buffer impedance when disabled	≥ 50	k Ω
Output current source or sink	≥ 1	mA
Current consumption (active)	≤ 1.0	mA

⁽⁶⁾Tolerance on this internal voltage is $\pm 5\%$

⁽⁷⁾Referred to the ideal conversion characteristic.

⁽⁸⁾See Figure 5.11, page 46

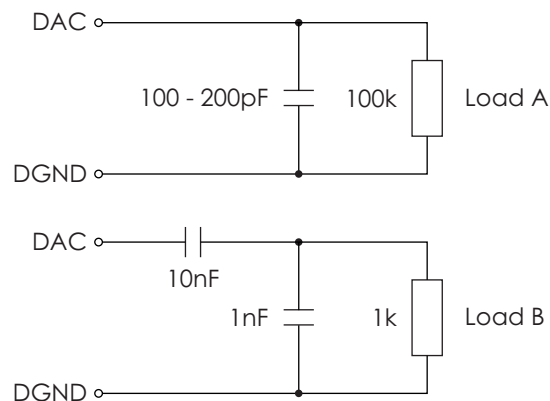

Figure 5.11 DAC loads

5.16.2 Analogue to Digital Converters 1, 2 and 3 - ADCx

The ADC is an 8-bit converter. An analogue value applied to any of the ADC pins is converted and stored in a register inside the radio device. When the appropriate AT command is received by the radio device, the digital value stored in the register is read.

ADC electrical characteristics are shown in the table below.

<i>Parameter</i>	<i>Min.</i>	<i>Max.</i>	<i>Units</i>
Resolution	8	8	Bits
Input voltage for 0000 0000 word	0	0.01 x 2.75 ⁽⁹⁾	V
Input voltage for 1111 1111 word	0.99 x 2.75 ⁽⁹⁾	2.75 ⁽⁹⁾	V
Differential Non-Linearity (DNL)		±0.75	LSB
Overall Non-Linearity (INL)		±0.60	LSB
Absolute accuracy		±1.5	LSB
Input impedance	1		MΩ
Average supply current (continuous conversion)		1	mA
External source impedance		50	kΩ

⁽⁹⁾ Tolerance on this internal voltage is ±5%

5.16.3 Analogue to Digital Converters 4 and 5 - IOx/ADCx

To increase analog input capabilities, the GR47 optimises the I/O by multiplexing or sharing different features on single pins. There are two ADC inputs which share system connector pins with digital I/O signals. When configured as digital I/O, the software will not read the voltages at the two new ADC inputs. When configured as ADC inputs the software will configure the digital I/O pins as input or high impedance tri-state. In this state any applied voltage between 0V and 2.75V can be read as an 8 bit value.

Because the ADC inputs, ADC4 and ADC5, are common with digital I/O, the input circuit of these Adds is not the same as for the circuits ADC1, ADC2 and ADC3. It is important to understand the input structure of the pin so that the correct analog voltage is read by the application (at position 'A' in Figure 5.12 below). The input structure is provided in Figure 5.12. It consists of a 100kΩ pull-up to 2.75V followed by a series 10kΩ and 1nF capacitor to ground which make a low pass filter with a 3dB roll-off at about 16kHz. The input impedance of the analog IC is 1MΩ minimum. At position 'A' in Figure 5.12 below, the input characteristics are the same as for the table above.

Note! If the voltage of the signal to be measured may be altered by the internal circuitry of this shared signal, then the application should use ADC1, ADC2 or ADC3 instead.

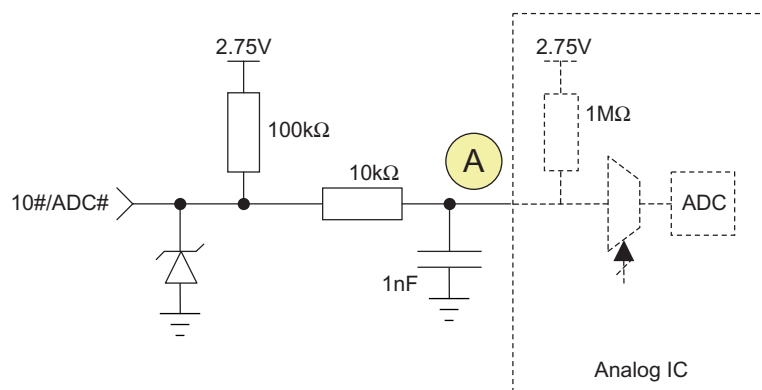

Figure 5.12 Input circuit for combined digital I/O and ADC pins

5.17 External I²C Serial Control Bus

Pin	Signal	Dir	Description
29	SDA	I/O	I ² C serial data
30	SCL	O	I ² C serial clock

The I²C bus is controlled by embedded application script commands.

The external I²C bus consists of two signals, SDA and SCL. This bus is isolated from the radio device's internal I²C bus to ensure proper operation of the radio device, in the event of the external I²C bus being damaged.

The electrical characteristics are shown below.

	Parameter	Min.	Typ.	Max.	Units
Transmit operation	Frequency I ² C CLK	81.25		400	kHz
	High or low I ² C CLK	1.2			μs
	Delay time after falling edge of I ² C CLK	308	308-1230		ns
	Hold time after falling edge of I ² C CLK	0			ns

	Parameter	Min.	Typ.	Max.	Units
Receive operation	Frequency I ² C CLK			400	kHz
	High or low I ² C CLK	1.2			μs
	Delay time after falling edge of I ² C CLK	100			ns
	Hold time after falling edge of I ² C CLK	0			ns

www.DataSheet4U.com

5.18 TX_ON - Burst Transmission

Pin	Signal	Dir	Description
35	TX_ON	O	GSM radio device to transmit

Burst transmission is the time when a GSM transceiver unit is transmitting RF signals. TX_ON indicates the radio device is going into transmission mode.

5.19 Real Time Clock

Pin	Signal	Dir	Description
25	VRTC	-	Voltage for the Real Time Clock

The Real Time Clock (RTC) provides the main microprocessor with a time-of-day calendar and alarm, and a one-hundred-year calendar. Its accuracy is shown in the table below

Parameter	Min.	Typ.	Max.	Units
RTC accuracy	25°C	8 (21)	20 (52)	ppm (s/month)
RTC accuracy	extreme temperatures	89 (231)	101 (262)	ppm (s/month)

The Real Time Clock operates in two modes when connected to a separate power supply:

- RTC normal mode: the radio device is in ON or OFF mode and it is supplied with power (VCC is applied).
- RTC back-up mode: VCC is disconnected and the RTC is maintained by a separate backup power supply connected to the VRTC input (see Figure 5.13 below).

Backup power is provided by a capacitor, golden-capacitor or battery in your application and must be connected to the VRTC pin. During RTC normal operation, the back up source will be charged.

In back-up mode, the back-up source must provide enough power for RTC operation. Refer to the table for the amount of current required.

The following table shows voltage characteristics for both modes.

<i>Parameter</i>	<i>Min.</i>	<i>Typ.</i>	<i>Max.</i>	<i>Units</i>
Supply Voltage RTC (normal mode - charging the capacitor)	1.6	1.8	2.0	V
Supply Voltage RTC (back-up mode - Capacitor provides the current)	1.0	1.8	2.0	V
Current drawn		5.0	10.0	µA

If the voltage drops below 1.0 V in back-up mode, the RTC will stop working. The following diagram shows the RTC connections.

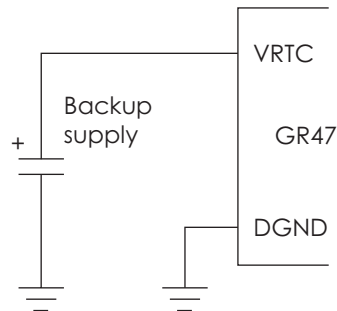

Figure 5.13 RTC connections

6. Antenna Connector

The radio device's antenna connector allows transmission of the radio frequency (RF) signals from the radio device to an external customer-supplied antenna. The connector is a micro-miniature coaxial MMCX surface mounted component. A number of suitable MMCX type, mating plugs are available from the following manufacturers;

- Amphenol;
- Suhner;
- IMS Connector Systems.

The nominal impedance of the antenna interface is 50Ω.

7. Keyboard Interface

To increase I/O capabilities, the radio device optimises the I/O by multiplexing or sharing different features on single pins. The I/O has been extended to allow simple interfacing of a matrix keypad.

7.1 IO#/KEYROW#

www.DataSheet4U.com

When configured for keypad operation the software will configure the digital I/O pins as input or high impedance tri-state. In this state, the keypad matrix row can be read from the KEYROW# inputs. These pins have a 100k Ω pull-up to 2.75V and the rows are considered activated when the voltage is pulled low by the external keypad switches.

7.2 KEYCOL#

The keypad matrix column drivers share functionality with the RS232 hardware flow control signals.

In addition to the keypad column outputs it is possible to use a direct ground connection as an additional column driver, which is interpreted as column zero.

Simply connect one keypad column directly to ground. When a key in this column is depressed KEYROW# is activated.

Thus it is possible to create a variety of keypad matrix sizes from single column to five columns wide.

Finally, a standard keypad matrix directly connects the rows to the columns whenever a key is depressed. In order to avoid short circuits if multiple keys are pressed simultaneously, the column drivers must be open-collector. This must be achieved with external transistors as the logic drive from the radio device is rail-to-rail. Suitable transistors for this interface are of the type with built in bias resistors between base and emitter.

The method of connection is shown below.

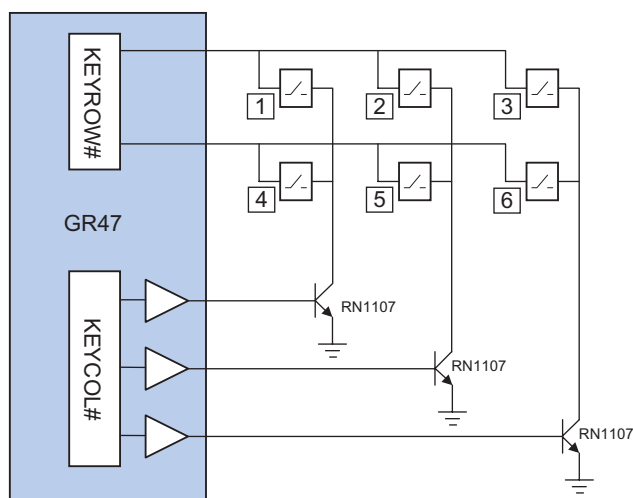

Figure 7.1 Keyboard matrix connections

Note! This matrix pattern may be repeated up to 5 columns and 4 rows (one column will use a ground connection as a virtual column driver).

Examples of suitable transistors are:

Brand	Part Number
Toshiba	RN1107 (as shown)
On SEMI	DTC114YET1
Philips	PDTC114YE
ROHM	DTC114YETL

8. Hints for Integrating the Radio Device

This chapter gives you advice and helpful hints on how to integrate the radio device into your application from a hardware perspective.

Please read and consider the information under the following headings before starting your integration work:

- Safety advice and precautions.
- Installation of the radio device.
- Antenna.

www.DataSheet4U.com

8.1 Safety Advice and Precautions

8.1.1 General

- Always ensure that use of the radio device is permitted. The radio device may present a hazard if used in proximity to personal medical electronic devices. As a rule, the radio device must not be used in hospitals, airports or planes.
- You are responsible for observing your country's safety standards, and where applicable the relevant wiring rules.
- Never use the radio device at a gas station, refuelling point, blasting area or in any other environment where explosives may be present.
- Operating the radio device close to other electronic devices, such as antennas, television sets, and radios may cause electromagnetic interference.
- Never try to dismantle the radio device yourself. There are no components inside the radio device that can be serviced by the user. If you attempt to dismantle the radio device, you may invalidate the warranty.
- To protect the power supply cables and meet the fire safety requirements, it is recommended that the electrical circuits are supplied with a power regulator. The power regulator should be placed as close to the terminals of the power supply as possible.
- Do not connect any incompatible component or product to the radio device.

Note! Sony Ericsson does not warrant against defects, non-conformities or deviations caused thereby.

- The connection/disconnection method for the development board is by means of the DC power jack. For this reason, the mains supply should be situated close to the development board and be easily accessible.

8.1.2 SIM Card

- Before handling the SIM card in your application, ensure that you are not charged with static electricity. Use proper precautions to avoid electrostatic discharges. The radio device must be switched off before the SIM card is installed in your application.
- When the SIM card hatch is opened, the SIM card connectors lie exposed under the SIM card holder. **CAUTION:** Do not touch these connectors! If you do, you may release an electrical discharge that could damage the radio device or the SIM card.
- When designing your application, the SIM card's accessibility should be taken into account. We always recommend that you have the SIM card protected by a PIN code. This will ensure that the SIM card cannot be used by an unauthorized person.

8.1.3 Antenna

- If the antenna is to be mounted outside, consider the risk of lightning. Follow the instructions provided by the antenna manufacturer.
- Never connect more than one radio device to a single antenna. The radio device can be damaged by radio frequency energy from the transmitter of another radio device.
- Like any mobile station, the antenna of the radio device emits radio frequency energy. To avoid EMI (electromagnetic interference), you must determine whether the application itself, or equipment in the application's proximity, needs further protection against radio emission and the disturbances it might cause. Protection is secured either by shielding the surrounding electronics or by moving the antenna away from the electronics and the external signals cable.
- The radio device and antenna may be damaged if either come into contact with ground potentials other than the one in your application. Beware, ground potential are not always what they appear to be.
- In the final application, the antenna must be positioned more than 20cm away from human bodies. When this rule cannot be applied, the application designer is responsible for providing the SAR measurement test report and declaration.
- Even if SAR measurements are not required, it is considered good practice to insert a warning in any manual produced, indicating it is a radio product and that care should be taken.

8.2 Installation of the Radio Device

8.2.1 Where to Install the Radio Device

There are several conditions which need to be taken into consideration when designing your application as they might affect the radio device and its function. They are:

Environmental Conditions

The radio device must be installed so that the environmental conditions stated in the Technical Data chapter, such as temperature, humidity and vibration are satisfied. Additionally, the electrical specifications in the Technical Data section must not be exceeded.

Signal Strength

The radio device has to be placed in a way that ensures sufficient signal strength. To improve signal strength, the antenna can be moved to another position. Signal strength may depend on how close the radio device is to a radio base station. You must ensure that the location at which you intend to use the radio device, is within the network coverage area.

Degradation in signal strength can be the result of a disturbance from another source, for example an electronic device in the immediate vicinity. More information about possible communication disturbances can be found in section 8.3.5, page 59.

When an application is completed, you can verify signal strength by issuing the AT command AT+CSQ. See the AT Commands Manual for further details.

Tip! Before installing the radio device, use an ordinary mobile telephone to check a possible location for it. In determining the location for the radio device and antenna, you should consider signal strength as well as cable length

Connection of Components to Radio Device

The integrator is responsible for the final integrated system. Incorrectly designed or installed, external components may cause radiation limits to be exceeded. For instance, improperly made connections or improperly installed antennas can disturb the network and lead to malfunctions in the radio device or equipment.

Network and Subscription

- Before your application is used, you must ensure that your chosen network provides the necessary telecommunication services. Contact your service provider to obtain the necessary information.

- If you intend to use SMS in the application, ensure this is included in your (voice) subscription.
- Consider the choice of the supplementary services described in section 2.3.2 Short Message Service, page 10.

8.2.2 How to Install the Radio Device

Power Supply

- Use a high-quality power supply cable with low resistance. This ensures that the voltages at the connector pins are within the allowed range, even during the maximum peak current. An electrolytic capacitor should be placed close to the power supply pins of the radio device to supply the peak currents during burst transmission. See 5.4 VCC - Regulated Power Supply Input, page 23.
- See section 5.2.1 General Protection Requirements, page 22.

Grounds

A ground connection is provided at the mounting hole next to the RF connector on the radio device (see Figure 5.1, page 19). Connect this ground point to the DGND pins of the radio device by the shortest, low-impedance path possible. The purpose of this connection is to allow any ESD picked up by the antenna to bypass the radio device's internal ground path.

Note! It is recommended that you use a cable with a maximum resistance of 5 m Ω for the ground connection.

Note! AGND and DGND are connected at a single point inside the radio device. They must *not* be joined together in your application.

Audio

Use a coupling capacitor in ATMS line if the application does not use the radio device's bias voltage. See also Figure 5.5 Microphone connections to the radio device, page 31.

Software Upgrade

To upgrade the software, the system connector must be accessible in your application. The pins SERVICE, TD2, RD2 and the power signals are used for this purpose. Please contact customer support for more details.

8.3 Antenna

8.3.1 General

The antenna is the component in your system that maintains the radio link between the network and the radio device. Since the antenna transmits and receives electromagnetic energy, its efficient function will depend on:

- the type of antenna (for example, circular or directional);
- the placement of the antenna;
- communication disturbances in the vicinity in which the antenna operates.

In the sections below, issues concerning antenna type, antenna placement, antenna cable, and possible communication disturbances are addressed.

In any event, you should contact your local antenna manufacturer for additional information concerning antenna type, cables, connectors, antenna placement, and the surrounding area. You should also determine whether the antenna needs to be grounded or not. Your local antenna manufacturer might be able to design a special antenna suitable for your the application.

8.3.2 Antenna Type

Make sure that you choose the right type of antenna for the radio device. Consider the following requirements:

- the antenna must be designed for the dual frequency bands in use:
E-GSM900/GSM1800 for the GR47 and
GSM850/GSM1900 for the GR48;
- the impedance of the antenna and antenna cable must be 50Ω ;
- the antenna output-power handling must be a minimum of 2 W;
- the VSWR value should be less than 3:1 to avoid damage to the radio device.

8.3.3 Antenna Placement

The antenna should be placed away from electronic devices or other antennas. The recommended minimum distance between adjacent antennas, operating in a similar radio frequency band, is at least 50 cm.

If signal strength is weak, it is useful to face a directional antenna at the closest radio base station. This can increase the strength of the signal received by the radio device.

The radio device's peak output power can reach 2 W. RF field strength varies with antenna type and distance. At 10 cm from the antenna the field strength may be up to 70 V/m and at 1 m it will have reduced to 7 V/m.

In general, CE-marked products for residential and commercial areas, and light industry can withstand a minimum of 3 V/m.

8.3.4 The Antenna Cable

Use 50 Ω impedance low-loss cable and high-quality 50 Ω impedance connectors (frequency range up to 2 GHz) to avoid RF losses. Ensure that the antenna cable is as short as possible.

The Voltage Standing-Wave Ratio (VSWR) may depend on the effectiveness of the antenna, cable and connectors. In addition, if you use an adapter between the antenna cable and the antenna connector, it is crucial that the antenna cable is a high-quality, low-loss cable.

Minimize the use of extension cables, connectors and adapters. Each additional cable, connector or adapter causes a loss of signal power.

8.3.5 Possible Communication Disturbances

Possible communication disturbances include the following:

- **Noise** can be caused by electronic devices and radio transmitters.
- **Path-loss** occurs as the strength of the received signal steadily decreases in proportion to the distance from the transmitter.
- **Shadowing** is a form of environmental attenuation of radio signals caused by hills, buildings, trees or even vehicles. This can be a particular problem inside buildings, especially if the walls are thick and reinforced.
- **Multi-path fading** is a sudden decrease or increase in the signal strength. This is the result of interference caused when direct and reflected signals reach the antenna simultaneously. Surfaces such as buildings, streets, vehicles, etc., can reflect signals.
- **Hand-over** occurs as you move from one cell to another in the GSM network. Your mobile application call is transferred from one cell to the next. Hand-over can briefly interfere with communication and may cause a delay, or at worst, a disruption.

9. Embedded Applications

The radio device has the capability to store and run customer written code in the form of a script during the processor's idle time, through the use of an on board interpreter.

9.1 Features

www.DataSheet4U.com

Main features of embedded applications are as follows.

- C based scripting language (Sony Ericsson specific);
- Over the air upgrade of scripts (NOT GSM software);
- Library of intrinsic functions;
- 2 scripts can be stored in the memory at any time but only 1 can be active.

9.2 Implementation

The radio device has up to 44k of space available for storage of two scripts in the scripting language and 25k of operating RAM. Structures included in this language are:

- If - then - else statements
- While loops
- For loops

All hardware interfaces that are normally available to the radio device through the AT commands are available to the embedded application.

Further drivers have been written such as M bus, keypad, SPI and I²C for use by the embedded application (EA) through the use of the I/O pins.

9.2.1 Limitations

Since the radio device is processing the script using its own memory, limitations are placed onto the scripts that are run.

- A direct comparison cannot be made to a fully compiled C program in terms of size but a gauge of script size is that if each line were 128 characters long in the script then the script could be 350 lines long.
- Processing power is something that needs to be considered as the script is run as a low priority process within the software. However, controller mode stops GSM operation and provides all the processing power for the script to be run. See the M2mpower Application Guide for more details.
- Code cannot be ported directly from an existing application and loaded directly onto the radio device. It must be re written in the Sony Ericsson Mobile script language so that the radio device interpreter can function correctly.

9.2.2 M2mpower IDE (Integrated Development Environment)

The IDE is a Windows based package which allows the user to write, simulate, debug and download the application into a radio device with the embedded application (EA) software. The standard version is designed to run on Windows XP and 2000, other versions are available for 98 if required.

The M2mpower Application Guide is available for implementing applications using the developer's kit and the embedded application (EA) functionality.

This is a required package to be able to implement an embedded application (EA).

For further information please contact Sony Ericsson Mobile Communications customer support.

10. TCP/IP Stack

An on board IP/TCP/UDP stack has been integrated into the software negating the need for the customer to implement one in their own code base.

This is only accessible by using an embedded applications (see section 9) using intrinsic functions.

www.DataSheet4U.com

10.1 Implementation

The following types of commands allow various functions:

- Open/closing IP connection - Negotiates/closes a dynamic IP address with the web server.
- Send/Receive TCP packets - Performs all TCP operations to send and receive packets.
- Send/Receive UDP packets - Performs all UDP operations to send and receive packets.
- Resolve URL to an IP address - Similar to nslookup command in DOS

When the unit is set up and controlled using the embedded applications either the embedded applications or an external application can generate data to be sent and pass it to the radio device for transmission.

This effectively provides a transparent communication link from the application to an internet server over GPRS.

11. Technical Data

Mechanical Specifications

Maximum length	50mm
Maximum width	33mm
Maximum thickness	6.82mm(excluding connector pins and top of antenna connector)
Weight	18.5g

www.DataSheet4U.com

Power supply voltage, normal operation

Voltage	3.6V nominal (3.4V - 4.0V)
Ripple	<100mV @ <200kHz; <20mV @ >200kHz
Voltage must always stay within a normal operating range, ripple included	
Power consumption	Voice/CSD: <250mA (<2A peak)
	Data (GPRS 4+1); <350mA (<2A peak)
	Idle mode: <5mA
	Switched off: <100µA

Radio specifications

Frequency range	GR47: E-GSM 900MHz and GSM 1800MHz (dual band) GR48: GSM 850MHz and GSM 1900MHz (dual band)
Maximum RF output power	GR47: 900MHz, Class 4, 2W; 1800MHz Class 1, 1W GR48: 850MHz, Class 4, 2W; 1900MHz Class 1, 1W
Antenna impedance	50Ω

SIM card

3 V or 5 V	Support of external SIM card
------------	------------------------------

Environmental specifications

Operating temperature range (full specification)	-10°C to +55°C
Operating temperature range (working)	-30°C to +75°C
Storage temperature range	-40°C to +85°C
Maximum relative humidity	95% at +40°C
Stationary vibration, sinusoidal	Displacement: 7.5mm Acceleration amplitude: 20m/s ² and 40m/s ² Frequency range: 2-8Hz, 8-200Hz, 200-500Hz
Stationary vibration, random	Acceleration spectral density (m ² /s ²): 0.96, 2.88, 0.96 Frequency range: 5-10Hz, 10-200Hz, 200-500Hz, 60min/axis
Non-stationary vibration, including shock	Shock response spectrum I, peak acceleration: 3 shocks in each axis and direction; 300m/s ² , 11ms Shock response spectrum II, peak acceleration: 3 shocks in each axis and direction; 1000m/s ² , 6ms
Bump	Acceleration: 250m/s ²
Free fall transportation	1.2m
Rolling pitching transportation	Angle: ±35degrees; period: 8s
Static load	10kPa
Low air pressure/high air pressure	70kPa/106kPa

Data Storage

SMS storage capacity	40 in ME In addition, the unit can handle as many SMS as the SIM can store
Phone book capacity	100

12. Declaration of Conformity

Declaration of Conformity

We, Sony Ericsson Mobile Communications AB of
Nya Vattentornet
S- 221 88 Lund, Sweden

declare under our sole responsibility that our product

Sony Ericsson type 6100511- BV

and in combination with our accessories, to which this declaration relates is in conformity with the appropriate standards 3GPP TS 51.010-1, EN 301489-7 and EN 60950, following the provisions of, Radio Equipment and Telecommunication Terminal Equipment directive 99/5/EC with requirements covering EMC directive 89/336/EEC, and Low Voltage directive 73/23/EEC.

CE 0682

Basingstoke, May 2003
Place & date of issue



Anders Franzén
Corporate Vice President M2M Com

We fulfil the requirements of the R& TTE Directive (99/5/EC).

Developer's Kit

13. Introduction to the Developer's Kit

The developer's kit for the radio devices is designed to get you started quickly. It contains all the hardware you will need to begin the development of an application. The only items you need to provide are; a computer, a SIM card and network subscription, and a knowledge of programming with AT commands.

Note! Before connecting up and using the developer's kit, we strongly recommend you read "Integrating the Radio Device", page 16 and all of this section. There are many switches, jumpers and connector options in the developer's kit. A knowledge of the functionality of the radio device is therefore essential before you start altering the hardware settings.

The main hardware in the developer's kit is a box, containing a board onto which you plug the radio device. Connectors, switches, jumpers and SIM card holder are provided to allow you to configure and access all the functions of the radio device.

13.1 Contents of the Kit

Please take the time to check the contents of your kit against the list shown below. If any of the items are missing contact your supplier immediately.

Developer's kit - Part Number DPY 102 225

<i>Description</i>	<i>Product Number</i>	<i>Qty</i>
Radio Device: GR47 or GR48	DPY 102 220 DPY 102 222	1
GR47/GR48 developer's kit (box and development board)	KRY 101 1919	1
Switched mode PSU 12V d.c.	BML 161 1014	1
UK mains plug	KRY 111 087	1
European mains plug	KRY 111 086	1
USA mains plug	KRY 111 088	1
9 pin serial connector cable	RPM 113 7796	1
Headset	RLF 501 40	1
Quad band antenna	KRE 101 1970	1
Data carrier/CD-ROM containing: Software Manual; Integrator's Manual	LZY 214 2583	1

13.2 General Functioning of the Kit

The following block diagrams are provided to help you understand the general principles of operation of the developer's kit.

You can use the kit's connectors to access and control the radio device (all switches and jumpers in their default positions).

Figure 13.1 shows the various on-board voltages and how they are fed to the radio device and other circuitry. The developer's board is powered by an external power supply connected to VCC, see below. The power to the developer's board circuitry is selectable from internal or external 3V6 source.

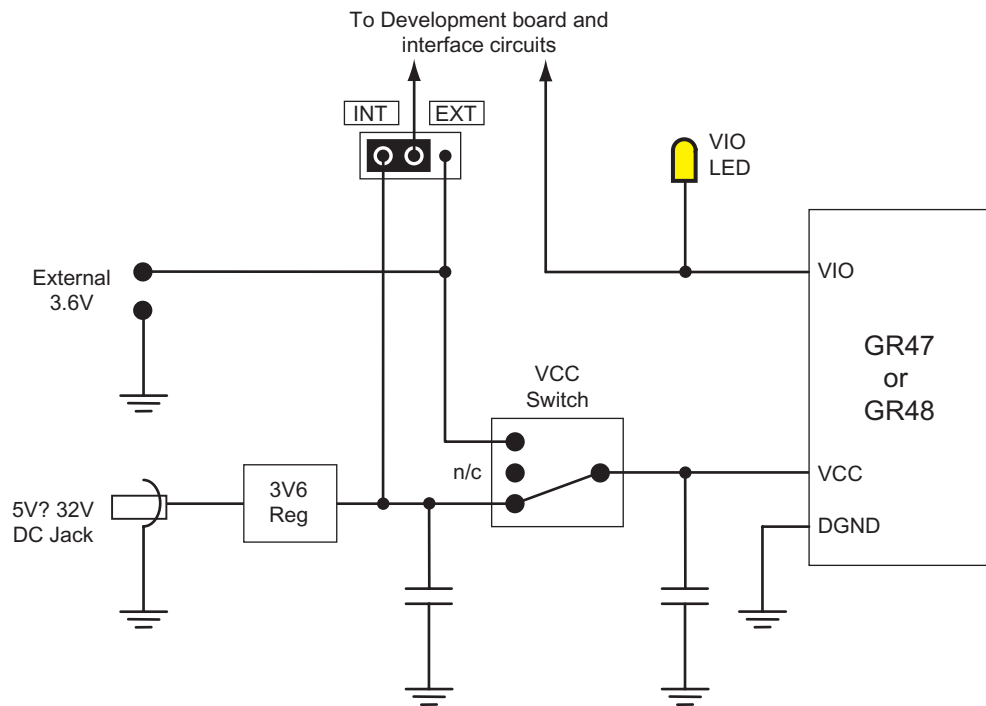

Figure 13.1 Power supply connection and the on-board voltages

Figure 13.2, Figure 13.3 and Figure 13.4 show how various signals are routed on the developer's board. Thicker lines indicate multiple signals.

www.DataSheet4U.com

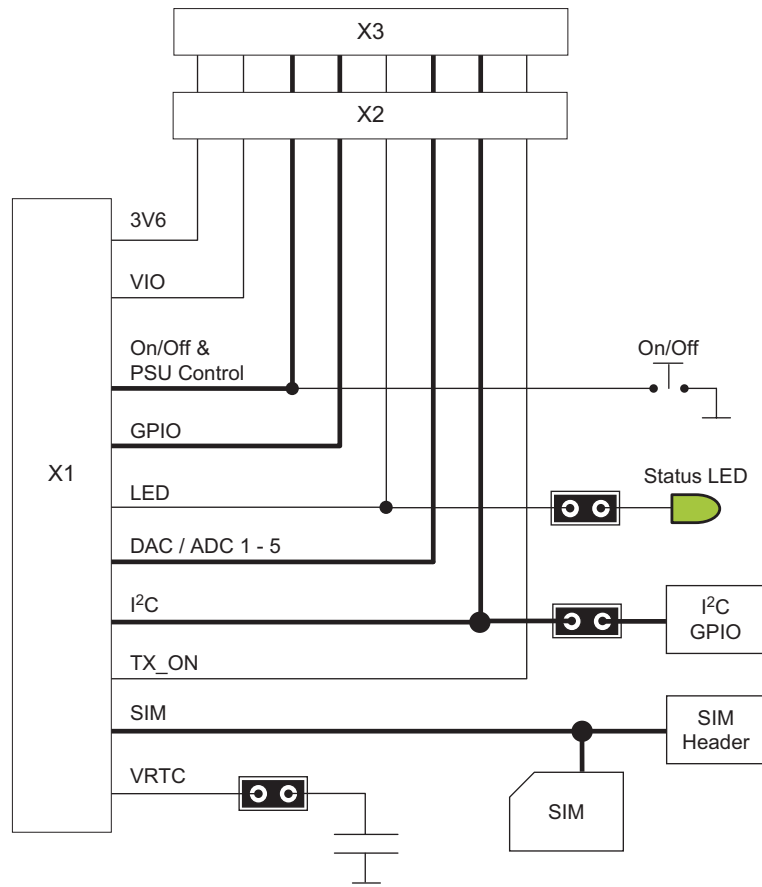

Figure 13.2 Miscellaneous signals, connection and routing

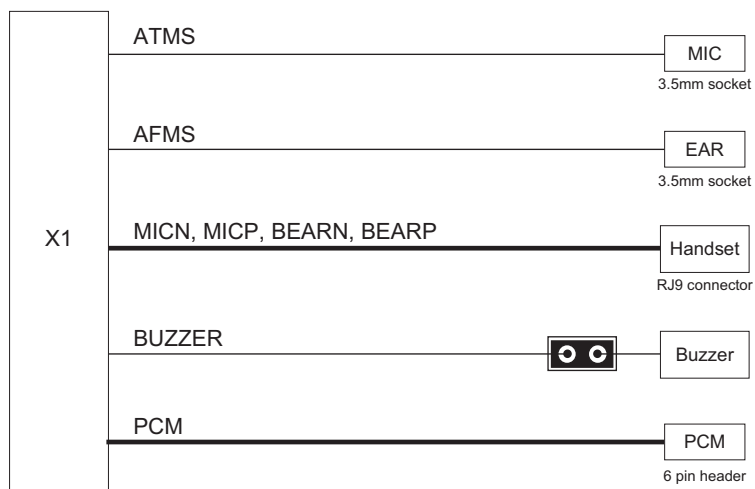

Figure 13.3 Audio signals, connection and routing

www.DataSheet4U.com

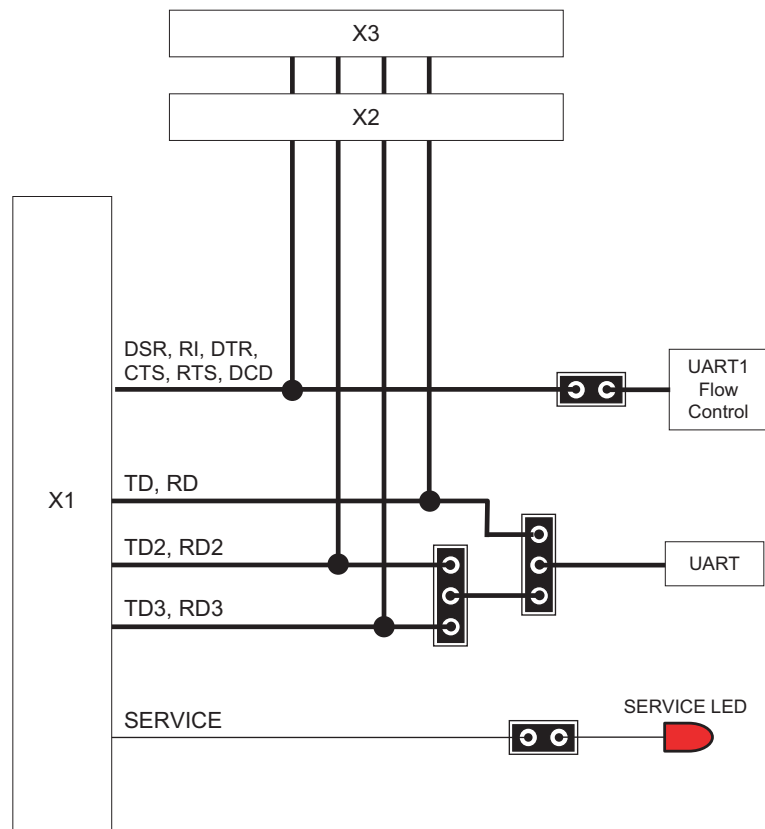

Figure 13.4 Comms signals, connection and routing

14. Using the Developer's Kit

This section provides you with the information needed to setup and use the developer's kit. Before changing switch and jumper settings, refer to "14.3 Jumpers", page 74.

Front and rear views of the developer's kit are shown below. Use a flat blade screwdriver to unhinge the side clips of the kit and lift the plastic lid off to access the inside.

www.DataSheet4U.com

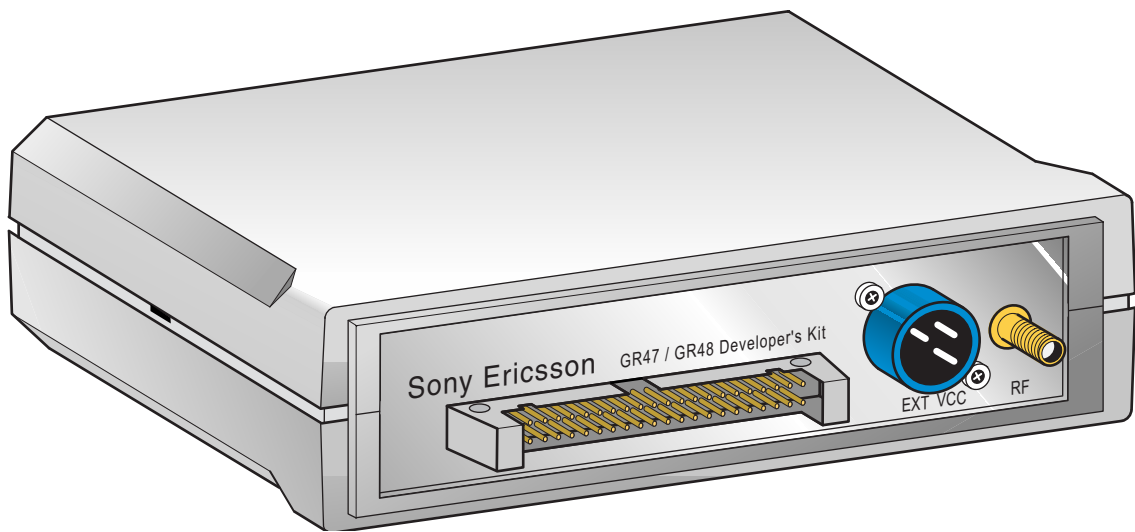

Figure 14.1 Front view

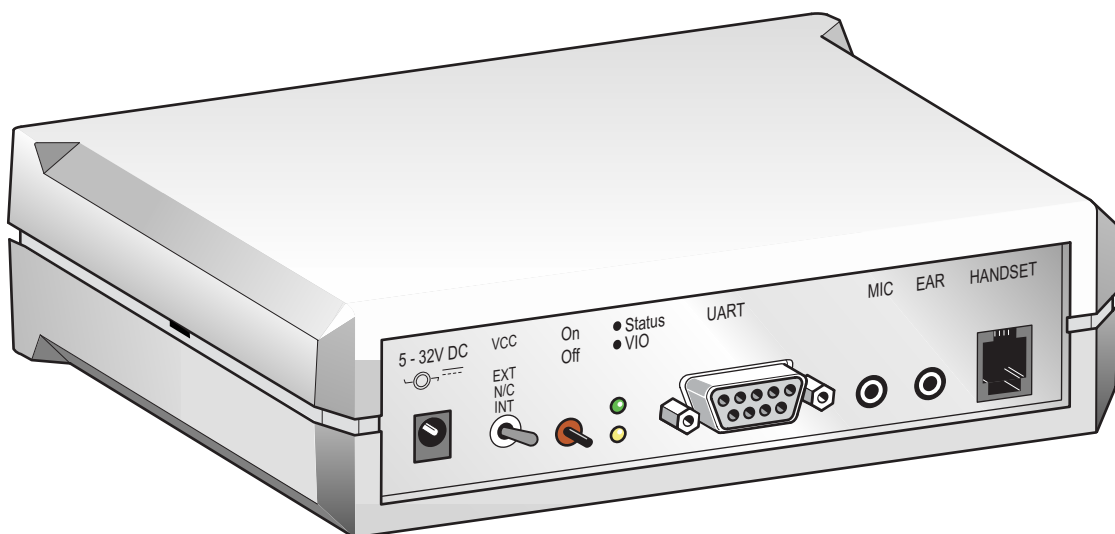

Figure 14.2 Rear view

14.1 Start up Check List

To use the developer's kit in standard format check the following:

- With the case lid removed, make sure the radio device is plugged into X1 and the RF lead is connected to the MMCX socket of the radio device;
- Add your SIM card;
- Check the jumpers are in their default positions. Refer to Figure 14.3;
- Connect the serial cable between your computer and the UART connector on the rear panel;
- Connect the antenna to the RF connector on the front panel;
- Connect the audio equipment if required;
- Plug the external power supply into the socket marked 5-32V DC on the rear panel;
- Switch Vcc to INT;
- Push ON/OFF for at least 2 seconds until the yellow VIO LED is on.

Your developer's kit should now be operational and ready to receive AT commands.

14.2 Developer's Board Overlay

Figure 14.3 shows the developer's board, including the position of all the connectors, switches and jumpers (default positions).

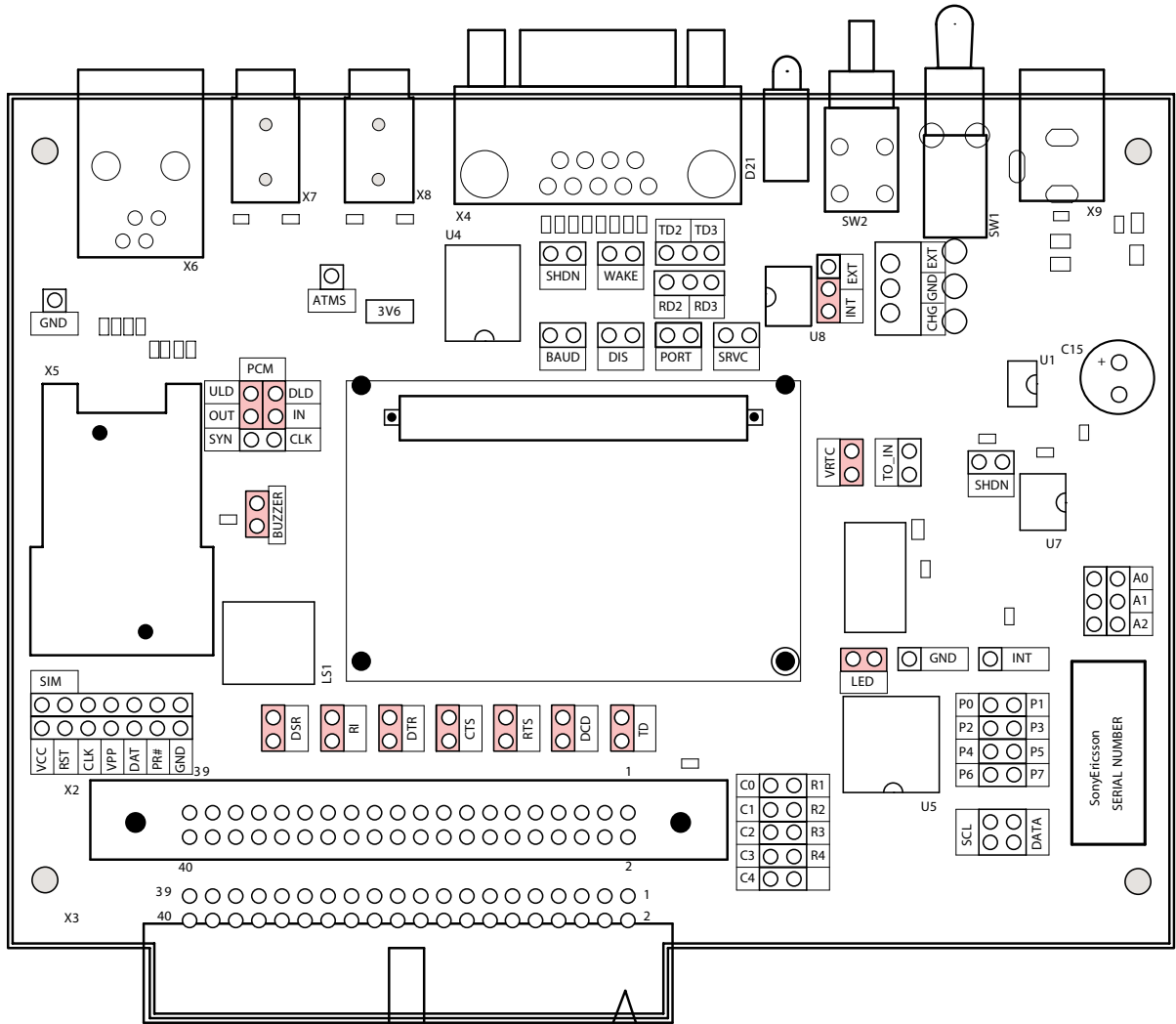

Figure 14.3 Developer's board overlay

14.3 Jumpers

All jumpers are located on the developer's board (see "Developer's board overlay", page 73).

Power and Control

<i>Jumper</i>	<i>Default</i>	<i>Description</i>
INT/EXT	INT	Selects which voltage path supplies the DK support circuitry (not the supply to the radio device). INT selects power from the internal +3.6V DC supply. EXT selects power from the EXT VCC connector.
TO_IN	-	With jumper TO_IN fitted, the DK and the radio device will automatically power-up as soon as power is applied to DC Jack X9.
SHDN	-	With jumper SHDN fitted, the internal +3.6V power supply will be disabled. Note: There is a second jumper labelled 'SHDN' which is in the UART area (by X4).
VRTC	Fitted	This jumper connects the DK real-time-clock backup capacitor to the VRTC pin of the radio device.

UART

<i>Jumper</i>	<i>Default</i>	<i>Description</i>
SRVC	-	When fitted, the module will be operated in 'Service' mode enabling system-status logging from the radio device. The red 'Service' LED will be illuminated.
PORT	-	When fitted, switches the serial port from the 'AT' command port UART1 to UART2/UART3. Note: Use the PORT jumper link in conjunction with links "TD2/TD3" and "RD2/RD3" to select between UART2/UART3.
TD2/TD3	-	This dual jumper selects the TD (Transmit Data) line for either UART2 or UART3 as the alternative serial port when jumper 'PORT' is fitted. The jumper connects TD2 or TD3 to the centre pin to make the selection. See "Connectors", page 80 for more details. Note: When UART2 or UART3 is used via the application connector, the TD2 or TD3 jumper must be removed to avoid circuit conflicts within the DK.
RD2/RD3	-	This dual jumper selects the RD (Receive Data) line for either UART2 or UART3 as the alternative serial port when jumper 'PORT' is fitted. The jumper connects RD2 or RD3 to the centre pin to make the selection. See "Connectors", page 80 for more details. Note: When UART2 or UART3 is used via the application connector, the RD2 or RD3 jumper must be removed to avoid circuit conflicts within the DK.

<i>Jumper</i>	<i>Default</i>	<i>Description</i>
DIS	-	When fitted, the serial port driver IC disables the receiver buffers that normally drive UART signals into the radio device. This will prevent the radio device from receiving data through the serial port.
WAKE	-	When fitted, the radio device will automatically power-up when the UART DTR signal is driven high. This allows a convenient mechanism for an external host computer to switch on the module. The DTR signal must be driven low or negative before the module can be switched off under software command. Note: If DTR is not driven low or negative and the host computer commands the module to shut-down, the DTR signal in its high state will immediately indicate that the module is to switch back on.
BAUD	-	When fitted, this jumper allows the serial port driver IC to operate at baud rates in excess of 250 kbps and up to 1 Mbps. Note: There will be an increase in current consumption with this option selected.
SHDN	-	When fitted, the serial port IC is forced into a low power state with the internal transmitters disabled. In the shut-down state the radio device will still receive commands but any transmission attempts from the radio device will be blocked by the serial port IC. Notes: In the shut-down state all the hardware flow control transmitters will be switched off. In order to send commands to the radio device in this state, the host computer must also have hardware flow control switched off. There is a second jumper labelled 'SHDN' which is in the Power Supply area (adjacent to U7).

Audio and PCM

Jumper	Default	Description
ULD	To OUT	To enable analog audio microphone path ULD must be connected to OUT using the jumper.
OUT	To ULD	To enable analog audio microphone path OUT must be connected to ULD using the jumper.
DLD	To IN	To enable analog audio earpiece path DLD must be connected to IN using the jumper.
In	To DLD	To enable analog audio earpiece path IN must be connected to DLD using the jumper.
SYN	-	This is an output connection for the PCM synchronisation signal from the radio device.
CLK	-	This is an output connection for the PCM clock signal from the radio device.
BUZZER	Fitted	When fitted, this link enables the DK buzzer driver circuitry.

Miscellaneous

Jumper	Default	Description
DSR	Fitted	Connects serial port flow control signal DSR between UART connector X4 and radio device. Note: DSR is a dual function signal from the radio device. When this signal is being used for any other purpose (e.g. Keypad or application specific through X2 or X3), this jumper must be removed.
RI	Fitted	Connects serial port control signal RI between UART connector X4 and radio device. Note: RI is a dual function signal from the radio device. When this signal is being used for any other purpose (e.g. Keypad or application specific through X2 or X3), this jumper must be removed.
DTR	Fitted	Connects serial port flow control signal DTR between UART connector X4 and radio device. Note: DTR is a dual function signal from the radio device. When this signal is being used for any other purpose (e.g. Keypad or application specific through X2 or X3), this jumper must be removed.
CTS	Fitted	Connects serial port flow control signal CTS between UART connector X4 and radio device. Note: CTS is a dual function signal from the radio device. When this signal is being used for any other purpose (e.g. Keypad or application specific through X2 or X3), this jumper must be removed.
RTS	Fitted	Connects serial port flow control signal RTS between UART connector X4 and radio device. Note: RTS is a dual function signal from the radio device. When this signal is being used for any other purpose (e.g. application specific I/O through X2 or X3), this jumper must be removed.

DCD	Fitted	Connects serial port control signal DCD between UART connector X4 and radio device. Note: DCD is a dual function signal from the radio device. When this signal is being used for any other purpose (e.g. Keypad or application specific through X2 or X3), this jumper must be removed.
TD	Fitted	Connects serial port Transmit Data signal TD between UART connector X4 and radio device. Note: It is only valid to have one Transmit Data buffer in the circuit. If TD is driven by the application through connector X2 or X3, this jumper must be removed to avoid circuit conflicts.
LED	Fitted	When fitted, this enables the STATUS LED to be illuminated by signal LED from the radio device. Note: LED is a dual function signal in the radio device. When this signal is being used for any other purpose (e.g. application specific I/O through X2 or X3), it is recommended that this jumper is removed to avoid circuit conflicts or unexpected circuit behavior.
SCL	-	When fitted, connects the I ² C clock signal from the radio device to the GPIO interface IC, U5. Note: Use the address selectors A0-A2 to set GPIO interface I ² C address. Ensure that the selected address is unique to all I ² C devices using SCL and SDA from radio device.
DATA	-	When fitted, connects the I ² C data signal from the radio device to the GPIO interface IC, U5. Note: Use the address selectors A0-A2 to set GPIO interface I ² C address. Ensure that the selected address is unique to all I ² C devices using SCL and SDA from radio device.
A0	-	When fitted, connects address pin A0 of IC U5 to logic high. When the jumper is not fitted, address A0 is held to logic low by the DK. Note: IC U5 address range is 0x70 to 0x7F.
A1	-	When fitted, connects address pin A1 of IC U5 to logic high. When the jumper is not fitted, address A1 is held to logic low by the DK. Note: IC U5 address range is 0x70 to 0x7F.
A2	-	When fitted, connects address pin A2 of IC U5 to logic high. When the jumper is not fitted, address A2 is held to logic low by the DK. Note: IC U5 address range is 0x70 to 0x7F.

14.4 Switches

All switches are mounted on the front panel of the developer's box.

Switch	Default	Description
Vcc (SW1)	N/C	<p>This switch chooses the voltage source that the radio device will use. The default state N/C makes the voltage path to the radio device open circuit. Choosing INT connects the internal +3.6V DC supply to the VCC pins of the radio device. Choosing EXT connects the external +3.6V DC supply to the VCC pins of the radio device.</p> <p>Note: The external +3.6V DC supply is a user provided source through the EXT VCC connector.</p>
ON/OFF (SW2)	-	<p>This is a momentary push-button switch to enable the user to manually turn the module on and off. The radio device is turned on by pressing and holding the ON/OFF switch for at least 1 second before releasing. The radio device is turned off by pressing and holding the ON/OFF switch for at least 2 second before releasing. The module will detect the OFF request and the software will perform all the necessary shutdown tasks (e.g. SIM power management and network detach) before the VIO LED is extinguished.</p> <p>Note: In the event of the radio device locking up and being unrecoverable under software control, the ON/OFF switch provides an alternative HARD SHUTDOWN control. To initiate the HARD SHUTDOWN feature press and hold the ON/OFF switch for at least 10 seconds or until the module powers down and VIO LED is no longer illuminated.</p>

14.5 Headers

Header	Connections	Description
PCM	ULD, DLD, OUT, IN, SYN, CLK	Carries digital audio PCM signals for access by user application. Note: In order for analog audio to be created internally by the radio device, signal ULD must be connected to OUT for the MIC path and signal DLD must be connected to IN for the EAR path.
SIM	VCC, RST, CLK, VPP, DAT, PR#, GND	This connector allows access to the SIM interface signals. These test points are connected in parallel with SIM connector 'X5'. Note: If this header is used to attach to an external SIM, an internal SIM fitted into connector 'X5' must be removed.
KEYPAD	C0, C1, C2, C3, C4, R1, R2, R3, R4	This header provides all the connections required to connect to a standard 20 key (5 columns x 4 rows) keypad matrix. 'C#' are output drivers to connect to keypad columns. 'R#' are input receivers to connect to keypad rows. Note: C0 is a virtual keypad column driver and is simply a connection to ground. C0 therefore does not appear on the radio device as a keypad driver output. The keypad interface recognises when the rows (R1-R4) are connected logic 'low'. If this is registered while the columns (C1-C4) are idle then it is accepted that the 'active' column is C0 (column zero).
I ² C GPIO	P0, P1, P2, P3, P4, P5, P6, P7, INT	This header provides a general purpose I/O port from the I ² C to GPIO interface. P0-P7 are the 8 bits of the data port. INT is the interrupt output of the interface. The interface IC which drives these signals is part number PCF8574AT from Philips Semiconductor.
ATMS	ATMS	In addition to being able to feed in a microphone signal from an alternative source, this pin can be used to answer an incoming telephone call. By momentarily connecting this signal to GND when an incoming call is 'ringing', the radio device will 'answer' the call.
GND	GND	These two headers can be used as the signal reference ground for test and measurement.

14.6 Connectors

Connector	Type	Description
RADIO DEVICE 'X1'	60 PinDual Row0.05" pitch	The radio device is 'plugged-in' to the development kit. This allows direct connection of the module to the development board.
APPLICATION 'X2'	40 PinDual Row0.1" pitch	This 40-pin connector is compatible with standard 0.1" pitch mating connectors and with 0.05" pitch IDC ribbon cable connectors. This allows the user a range of connection methods to interface to the application. This connector is wired in parallel with application connector 'X3', which can be used for test probing or to wire patch alternative signals into the four 'N/C' pins.
APPLICATION 'X3'	40 PinDual Row0.1" pitch	This 40-pin connector is compatible with standard 0.1" pitch mating connectors and with 0.05" pitch IDC ribbon cable connectors. This allows the user a range of connection methods to interface to the application. This connector is wired in parallel with application connector 'X2', which can be used for test probing or to wire patch alternative signals into the four 'N/C' pins.
UART 'X4'	9-pin D Female Socket	<p>This is a full 9-pin RS232 compatible communication port. Using jumpers on the DK, this connector may be used for UART1, UART2 or UART3 of the radio device.</p> <p>Note: UART2 and UART3 of the radio device are considered 3-wire interface only. The hardware flow and other control signals which are passed through this connector are only relevant when used with UART1.</p>
SIM 'X5'	Latch and lift style holder with integral SIM detect contact	This is a standard holder for a GSM SIM card. The top piece slides towards "Open" and then lifts to release or insert the SIM card using the integral guide rails. To close, lower the pivoting top piece flush with the bottom piece and slide the top towards "Lock".

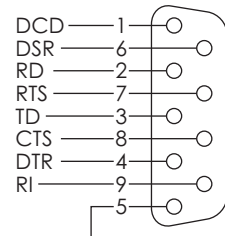

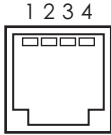
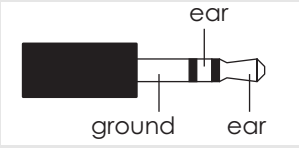
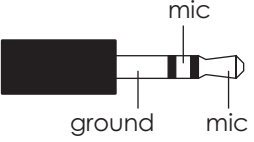
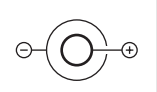
Connector	Type	Description
Handset 'X6'	RJ9 socket	 <p>Connector for a standard telephone handset. Carries signals from the balanced outputs BEARN and BEARP and to the balanced inputs MICN and MICP. To enable an analog audio link it is necessary to link PCM signals "ULD to OUT" and "DLD to IN" using jumper links on the PCM header.</p> <p>Note: The PCM links to enable analog audio are fitted by default but may have been removed during customer development. There will be no analog audio without these links. Please check carefully.</p>
EAR 'X7'	3.5mm Stereo JackSocket	<p>This is a standard unbalanced audio output (AFMS) which is compatible with a standard PC-style stereo headset.</p> <p>Note: This MONO audio signal is fed to both left and right channels of the stereo connector. To enable this analog audio link it is necessary to link PCM signal DLD to signal IN using a jumper link on the PCM header.</p> <p>Note: The PCM links to enable analog audio are fitted by default but may have been removed during customer development. There will be no analog audio without these links. Please check carefully.</p> 
MIC 'X8'	3.5mm Stereo JackSocket	<p>This is a standard unbalanced audio input (ATMS) which is compatible with a standard PC-style microphone.</p> <p>Note: Microphone bias voltage is provided through this connector in the range 2.0VDC to 2.5VDC. To enable this analog audio link it is necessary to link PCM signal ULD to signal IN using a jumper link on the PCM header.</p> <p>Note: The PCM links to enable analog audio are fitted by default but may have been removed during customer development. There will be no analog audio without these links. Please check carefully.</p> 
5 - 32V DC 'X9'	2.1mm DC Jack Socket	<p>Allows connection of an external power supply in the voltage range +5.0VDC to +32.0VDC at 4 Watts.</p> 

Connector	Type	Description
EXT VCC	3 pin Circular	<p>This connector carries three signals: EXT VCC (1); CHG_IN (3); GND (2). (These signals are wired into PCB holes labelled EXT, CHG, GND respectively). EXT VCC must be a +3.6VDC source capable of supplying up to 2.0A. This can be a battery source. CHG_IN can be a +5.0VDC source capable of supplying 600mA maximum. GND is the ground reference to be used by the external supplies.</p> <p>Note: If battery charging is enabled the charging source must be capable of supplying the required charging current but the charging current must not exceed 500mA.</p>
RF	SMA Panel Socket	Connect the supplied antenna.



14.7 LED Indicators

LED (Colour)	Location	Description
Status (Green)	Front Panel	<p>This LED is enabled by fitting the "LED" jumper link (located between the internal power supply and the keypad header). The LED is driven on by a signal from the radio device pin 33 (LED/IO6). When the radio device connection "LED/IO6" is configured as the LED driver this LED signifies the module and network status as follows: ON - Module cannot connect to a network. FLASHING - MODULE has SIM fitted and is locked onto a valid GSM network.</p>
VIO (Yellow)	Front Panel	This LED is illuminated when the radio device is switched on. The module outputs +2.75VDC on signal VIO (pin 34).
SRVC (Red)	PCB	When the SRVC jumper link is fitted and the DK has +3.6VDC power, this LED illuminates to indicate that SERVICE mode is activated.
3V6 (Green)	PCB	<p>When the DK has +3.6VDC power, this LED will illuminate. Note: The DK +3.6V and the radio device VCC inputs are connected through switch VCC (SW1) on the front panel. The 3V6 LED does NOT indicate that the module has power applied to its VCC connections.</p>

14.8 System Connector Pin Assignments

Refer to the table below when monitoring signals on, or connecting to, X1. The table shows the system-connector pin assignments for the radio devices. See “System Connector Interface”, page 19 for more details.

1	VCC	DGND	2
3	VCC	DGND	4
5	VCC	DGND	6
7	VCC	DGND	8
9	VCC	DGND	10
11	CHG_IN	DGND	12
13	IO5/ADC4	ON/OFF	14
15	SIMVCC	SIMPRESENCE	16
17	SIMRST	SIMDAT	18
19	SIMCLK	DAC	20
21	IO1/KEYROW2	IO2/ADC5	22
23	IO3/KEYROW3	IO4/KEYROW4	24
25	VRTC	ADC1	26
27	ADC2	ADC3	28
29	SDA	SCL	30
31	BUZZER	DSR/O3/KEYCOL3	32
33	LED/IO6	VIO	34
35	TX_ON	RI/O2/KEYCOL2	36
37	DTR/IN1/KEYROW1	DCD/O1/KEYCOL1	38
39	RTS/IO9	CTS/O4/KEYCOL4	40
41	TD	RD	42
43	TD3/IO7	RD3/IO8	44
45	TD2	RD2	46
47	PCMULTD	PCMDLD	48
49	PCMOUT	PCMIN	50
51	PCMSYNC	PCMCLK	52
53	MICP	MICN	54
55	BEARP	BEARN	56
57	AFMS	SERVICE	58
59	ATMS	AGND	60

Figure 14.4 System connector pin assignments

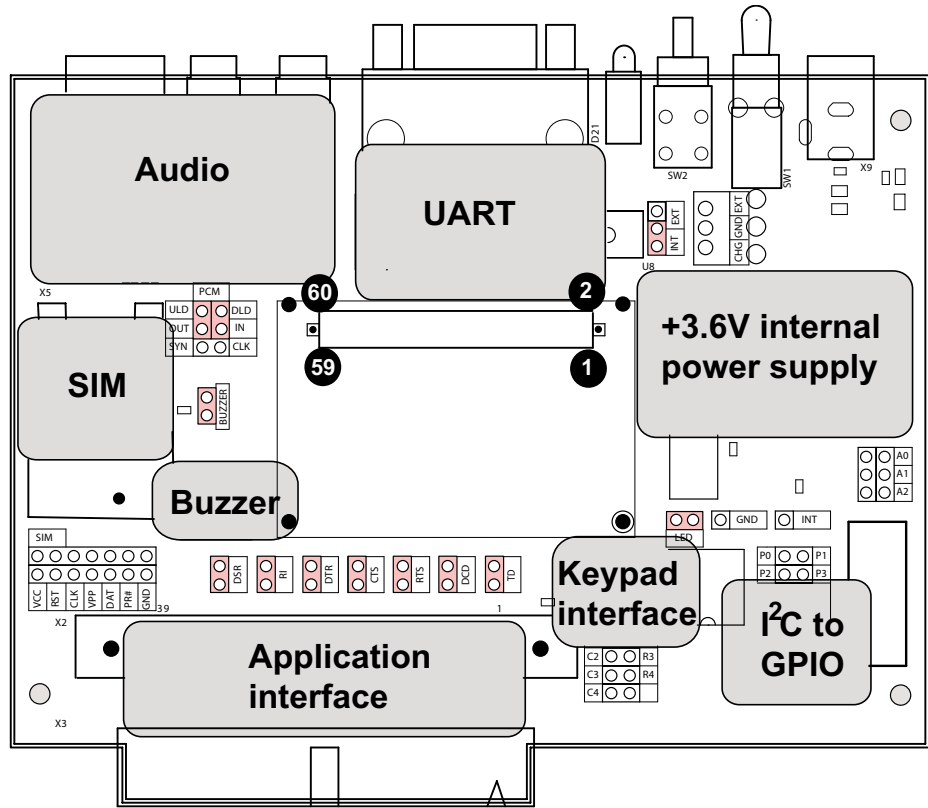

X1 pin numbering viewed from the front of the developer's kit.

Figure 14.5 Pin Orientation and Board assignments

VCC	1	2	VCC
DGND	3	4	DGND
ON/OFF	5	6	TO IN
HR_IN	7	8	n/c
IO1 / KEYROW2	9	10	IO2 / ADC5
IO3 / KEYROW3	11	12	IO4 / KEYROW4
VIO	13	14	DGND
IO5 / ADC4	15	16	ADC1
ADC2	17	18	ADC3
DAC	19	20	DGND
LED / IO6	21	22	TXON
SDA	23	24	SCL
DGND	25	26	n/c
RX	27	28	TX
RTS / IO9	29	30	CTS / KEYCOL4 / OUT4
DSR / KEYCOL3 / OUT3	31	32	RI / KEYCOL2 / OUT2
DCD / KEYCOL1 / OUT1	33	34	DTR / KEYROW1
TX2	35	36	RX2
TX3	37	38	RX3
n/c	39	40	n/c

Figure 14.6 Application Interface Connector (X2 and X3) - Pin Assignment