

Self-oscillating Half-bridge Power IC

Features

- Integrated half-bridge 440V power MOSFET
- Floating channel designed for bootstrap operation
- Noise immunity of transient voltage
- Under-voltage lockout
- Programmable oscillator frequency
- Matched propagation delay for both channels
- Ultra low startup current of 75uA
- Shutdown function turns off both channels
- Low side output in phase with R_T

Applications

- Compact fluorescent lamps (CFL)
- Cathode compact fluorescent lamp (CCFL)

Description

GR6953 is a high voltage monolithic IC with integrated 440V half-bridge power MOSFET. Proprietary HVIC and latch immune CMOS technologies enable ruggedized monolithic construction. The front end features a programmable oscillator which is similar to the 555 timer. The output drivers feature a high pulse current buffer stage and an internal dead time designed for minimum driver cross-conduction. Propagation delays for the two channels are matched to simplify use in 50% duty cycle applications.

Ordering and Marking Information

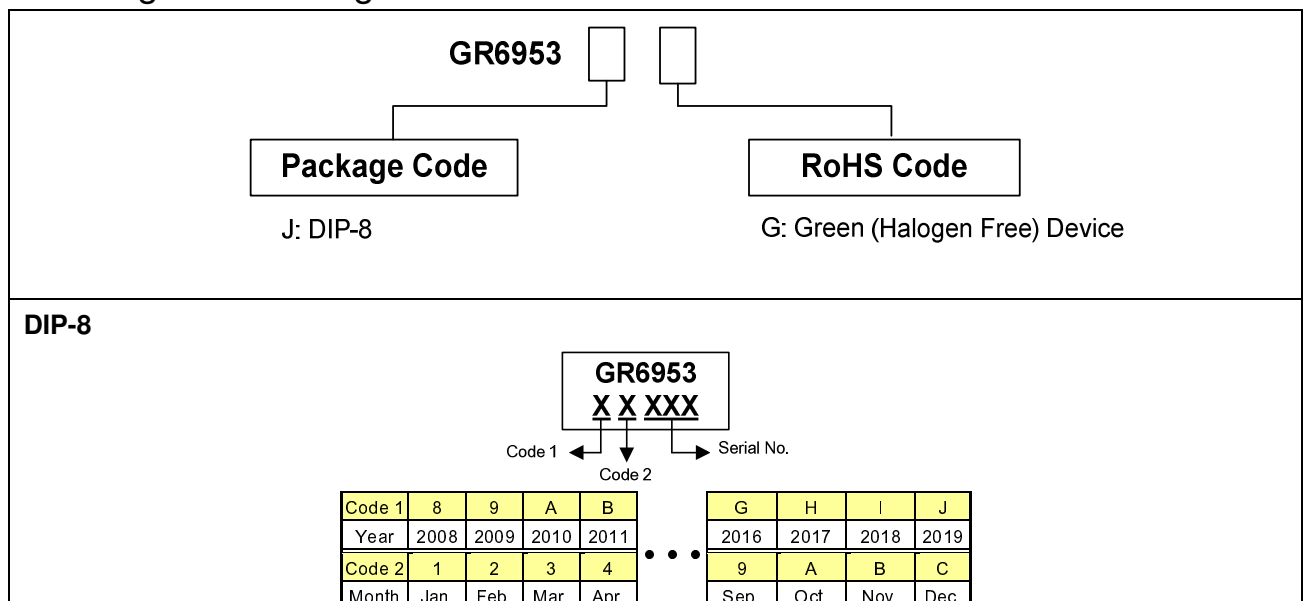

Greenergy OPTO Inc. reserves the right to make changes to improve reliability or manufacture ability without notice, and advise customers to obtain the latest version of relevant information to verify before placing orders.

Pin Configuration

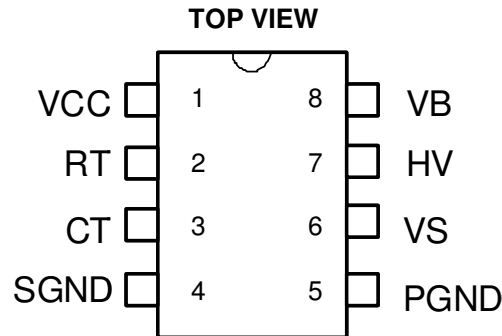

Pin Description

Pin No.	Name	Function
1	VCC	Low side and logic fixed supply
2	RT	Oscillator timing resistor input, in phase with HO for normal IC operation
3	CT	Oscillator timing capacitor input, the oscillator frequency according to the following equation: $f = 0.7213 / (RT \times CT)$
4	SGND	Signal ground
5	PGND	Low side MOSFET source
6	VS	High side floating supply return and power output
7	HV	High side MOSFET drain
8	VB	High side floating supply

Block Diagram

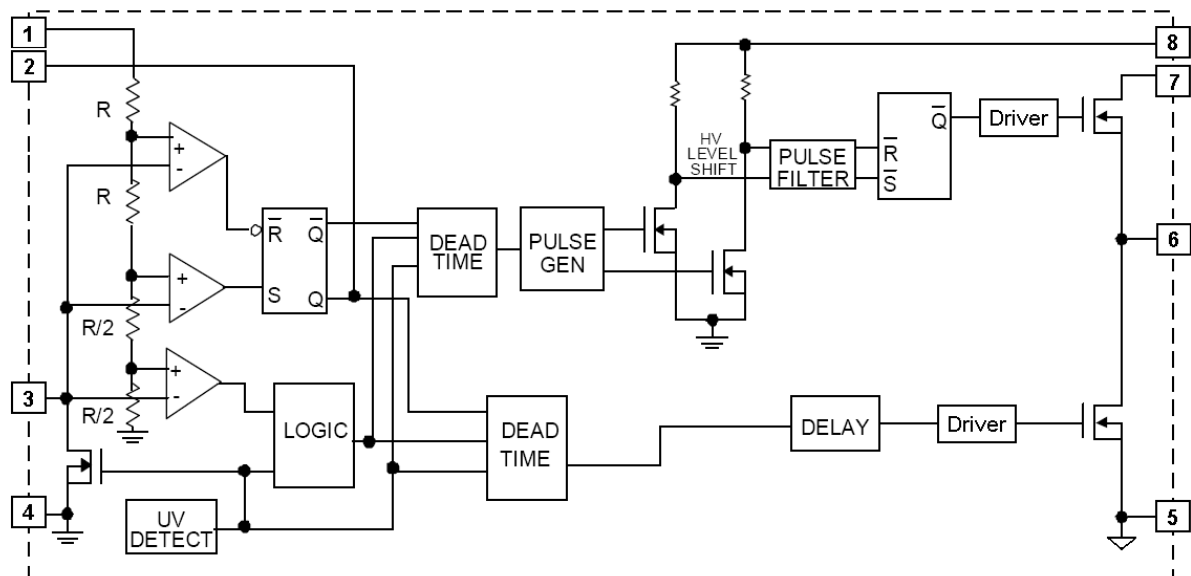

Absolute Maximum Ratings

Supply voltage VCC	-----	19V
VB	-----	-0.3V ~ 440V
VS	-----	VB-25V ~ VB+0.3V
HV	-----	VS-0.3V ~ VB+0.3V
RT, CT	-----	-0.3V ~ VCC+0.3V
Junction temperature	-----	150°C
Operating ambient temperature	-----	-20°C ~ 85°C
Storage temperature range	-----	-65°C ~ 150°C
DIP-8 package thermal resistance	-----	100°C/W
Power dissipation (DIP-8, at ambient temperature = 85°C)	-----	650mW
Lead temperature (All Pb free packages, soldering, 10sec)	-----	260°C
ESD voltage protection, human body model	-----	2KV
ESD voltage protection, machine model	-----	200V

Recommended Operating Conditions

Item	Min.	Max.	Unit
Supply voltage VCC	10	18	V
Supply voltage VBS	VCC-0.7	18	V
Supply voltage HV		400	V
CFL (Input power)		23	W

Electrical Characteristics

(VCC = 12V, HV = 12V, Cboot = 0.1uF, CL = 1nF, CT = 1nF, Dboot is a ultra fast diode, and Ta = 25°C, unless otherwise specified. The VIN, VTH and IIN parameters are referenced to SGND = PGND = 0V)

Parameter	Conditions	Symbol	Min.	Typ.	Max.	Unit
-----------	------------	--------	------	------	------	------

LOW VOLTAGE SUPPLY CHARACTERISTICS

Rising VCC under-voltage lockout threshold		V _{CCUV+}	8.1	9.0	9.9	V
Falling VCC under-voltage lockout threshold		V _{CCUV-}	7.2	8.0	8.8	V
VCC under-voltage lockout Hysteresis		V _{CCUVH}	0.5	1.0	1.5	V
Micropower startup VCC supply current	V _{CC} ≤ V _{CCUV}	I _{QCCUV}	—	50	100	μA
Quiescent VCC supply current		I _{QCC}	—	160	300	μA
VCC operating voltage		V _{op}	10	12	18	V

OSCILLATOR I/O CHARACTERISTICS

Oscillator frequency (CT=1nF)	RT = 36k	f _{osc}	19.4	20	20.6	kHz
	RT = 7.2k		94	100	106	kHz
RT pin duty cycle	f _{osc} < 100kHz	d	48	50	52	%
CT pin current		I _{CT}	—	0.001	1.0	uA
UV-mode CT pin pulldown current	V _{CC} = 7V	I _{CTUV}	0.25	0.30	0.5	mA
Upper CT ramp voltage threshold		V _{CT+}	—	8.0	—	V
Lower CT ramp voltage threshold		V _{CT-}	—	4.0	—	V
CT voltage shutdown threshold		V _{CTSD}	4.0	4.1	4.2	V
High-level RT output voltage, VCC - VRT	I _{RT} = 100uA	V _{RT+}	—	10	50	mV
	I _{RT} = 1mA		—	100	300	mV
Low-level RT output voltage	I _{RT} = 100uA	V _{RT-}	—	10	50	mV
	I _{RT} = 1mA		—	100	300	mV
UV-mode RT output voltage	V _{CC} ≤ V _{CCUV}	V _{RTUV}	—	0	100	mV
SD-Mode RT output voltage, VCC - VRT	I _{RT} = 100uA	V _{RTSD}	—	10	50	mV
	V _{CT} = 0V		—	100	300	mV
	I _{RT} = 1mA		—	10	50	mV
	V _{CT} = 0V		—	100	300	mV

Electrical Characteristics (Cont.)
BUILT-IN MOSFET CHARACTERISTICS

Parameter	Conditions	Symbol	Min.	Typ.	Max.	Unit
Drain – source break down voltage	$V_{GS} = 0V, I_D = 250\mu A$	BV_{DSS}	440			V
Peak drain current @ $V_{GS}=10V$	$T_a = 25^\circ C$	I_D			1.5	A
Drain - source on state resistance	$V_{GS}=10V, I_D=0.2A$	$R_{ds(on)}$		3.0	3.5	Ω
Drain – source leakage current	$V_{DS} = 400V, V_{GS} = 0V,$ $T_j = 25^\circ C$	I_{DSS}			25	μA
	$V_{DS} = 400V, V_{GS} = 0V,$ $T_j = 125^\circ C$				250	
Gate threshold voltage	$V_{DS} = V_{GS},$ $I_D = 250\mu A$	V_{TH}	2	3	4	V
Diode forward voltage	$V_{DS} = 0V,$ $I_D = 0.3A$	V_{SD}			1.0	V

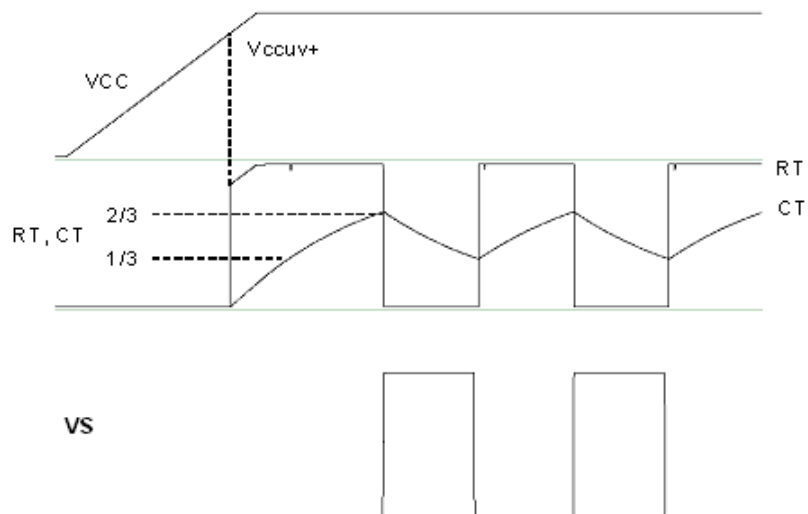
Input / Output Timing Diagram

$$f_{osc} = 0.7213 / (R_T \times C_T) \quad (\text{kHz})$$

Typical Performance Characteristics

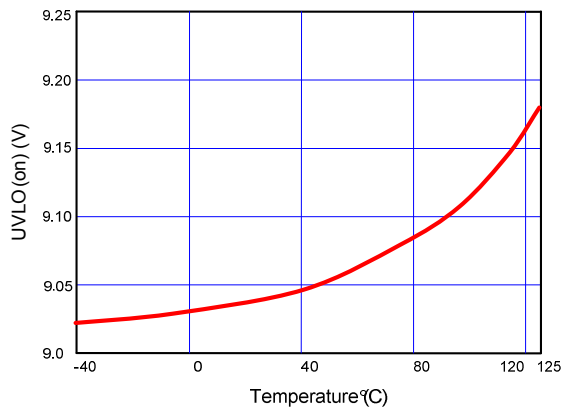

Fig. 1 UVLO(on) vs. Temperature

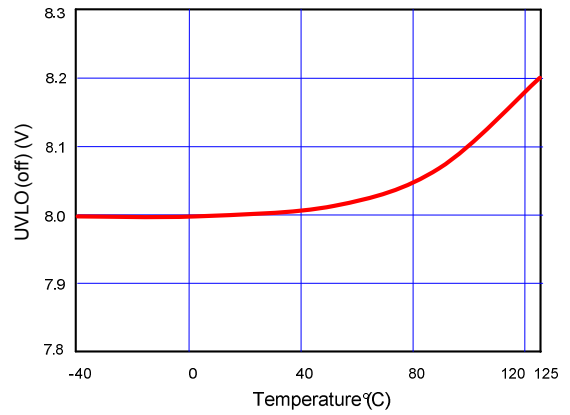

Fig. 2 UVLO(off) vs. Temperature

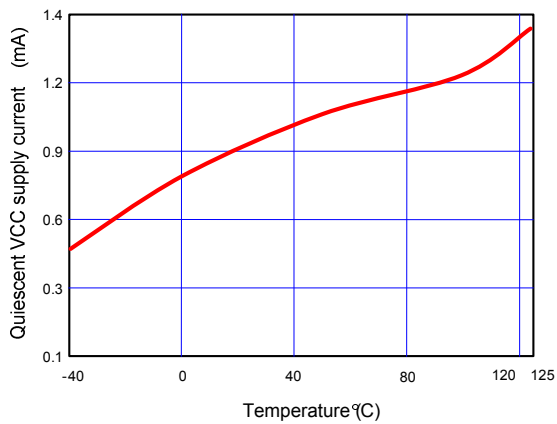

Fig. 3 Quiescent VCC supply current vs. Temperature

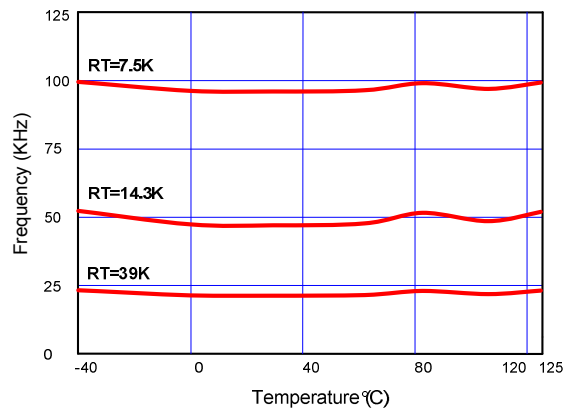

Fig. 4 Frequency vs. Temperature

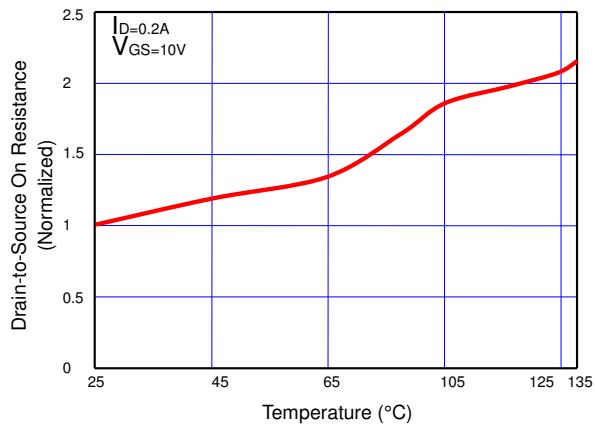
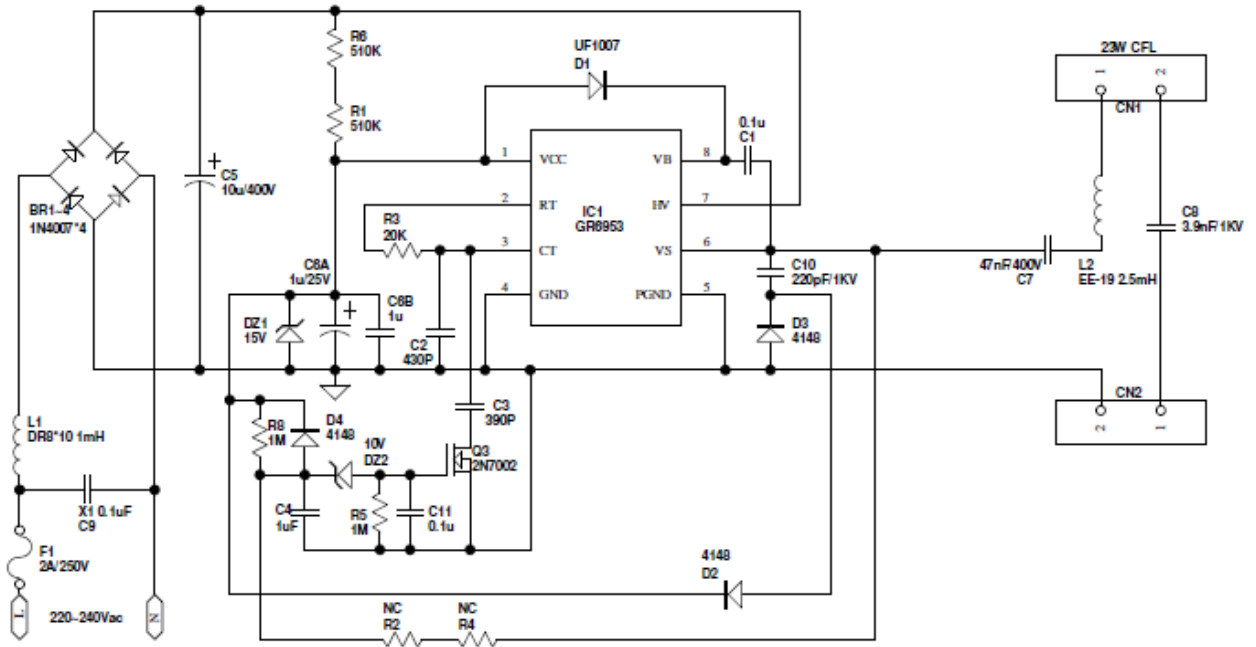
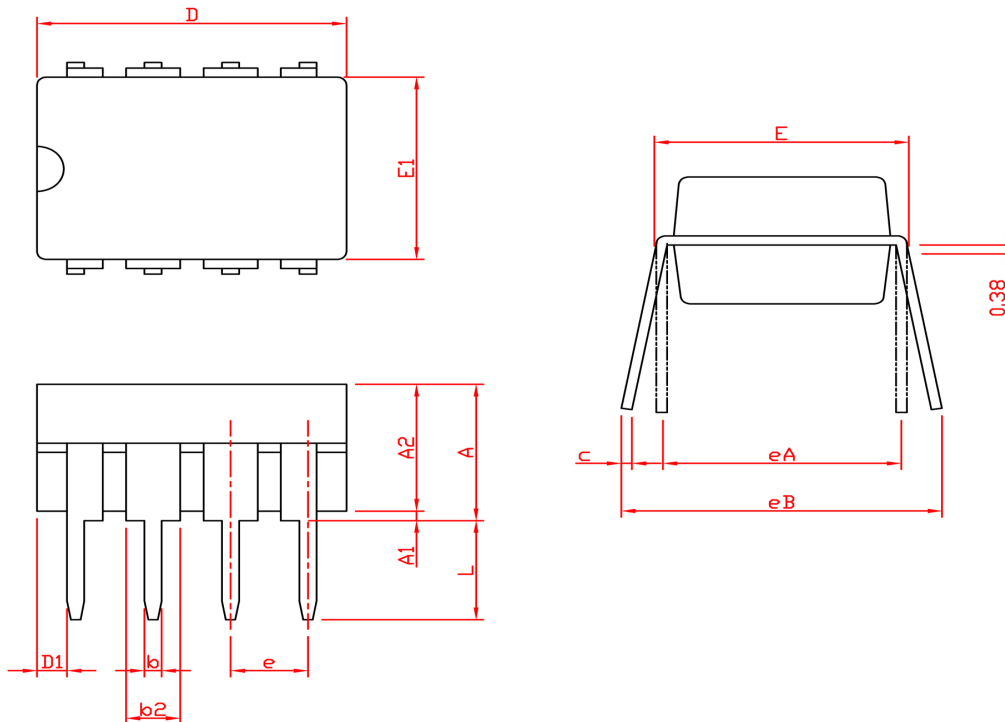

Fig. 5 Rds(on) vs. Temperature

Typical Application Circuit (220~240Vac 23W CFL)

Package Information

SYMBOL	DIP-8			
	MILLIMETERS		INCHES	
	MIN.	MAX.	MIN.	MAX.
A		5.33		0.210
A1	0.38		0.015	
A2	2.92	4.95	0.115	0.195
b	0.36	0.56	0.014	0.022
b2	1.14	1.78	0.045	0.070
c	0.20	0.35	0.008	0.014
D	9.01	10.16	0.355	0.400
D1	0.13		0.005	
E	7.62	8.26	0.300	0.325
E1	6.10	7.11	0.240	0.280
e	2.54 BSC		0.100 BSC	
eA	7.62 BSC		0.300 BSC	
eB		10.92		0.430
L	2.92	3.81	0.115	0.150

Note : 1. Followed from JEDEC MS-001 BA

2. Dimension D, D1 and E1 do not include mold flash or protrusions. Mold flash or protrusions shall not exceed 10 mil.

Greenergy OPTO, Inc. reserves the right to make corrections, modifications, enhancements, improvements, and other changes to its products and services at any time and to discontinue any product or service without notice. Customers should obtain the latest relevant information before placing orders and should verify that such information is current and complete.