

## LCD Module Technical Specification

Part No. : GS-GG1286463FFWJ/R

Customer :

Customer Approved

Approved	Checked	Prepared
		



Genda Technology (Shenzhen) Ltd.

ADDRESS: *Friendship Industrial Building, 71 District,  
Baoan, Shenzhen, P.R. China.*

POST CODE: 518101  
 TEL: 86-755-27865012  
 FAX: 86-755-27865217  
 E-MAIL: gme.43@gendalcd.com

## **CONTENTS**

1. RECORD OF REVISION
2. GENERAL SPECIFICATION
3. DISPLAY CONTENT AND MECHANICAL CHARACTERISTIC
4. MODULE DRAWING
5. BLOCK DIAGRAM
6. APPLICATION CIRCUIT
7. INTERFACE DESCRIPTION
8. ELECTRICAL CHARACTERISTICS
9. ABSOLUTE MAXIMUM RATINGS
10. ELECTRO-OPTICAL CHARACTERISTICS
11. RELIABILITY OF LCD MODULE
12. AC CHARACTERISTICS
13. COMMANDS TABLE
14. LCD MODULE QUALITY STANDARD
15. HANDLING PRECAUTIONS
16. PACKING SPECIFICATIONS

**1. RECORD OF REVISION**

Date	Ver.	Description	Page	Design by
2011-02-24	00	First issue	20	LSX

## 2. GENERAL SPECIFICATION

### 2.1 GENERAL SPECIFICATION

PLEASE REFER TO:

- a. "CUSTOMER ACCEPTANCE STANDARD SPECIFICATIONS (LCD MOUDLE QUALITY STANDARD) "
- b. "CUSTOMER ACCEPTANCE STANDARD SPECIFICATIONS (IC-SPLC501C)"

**2.2** This individual specification is prior to general specifications.

**2.3** Assemblies shall comply with RoHS requirements.

## 3. DISPLAY CONTENT AND MECHANICAL CHARACTERISTIC

ITEM	STANDARD VALUE	UNIT
Number of dots	128*64 Dots	----
Module dimension	93.7(L)*52.4(W)*5.5(H)	mm
View display area	70.7(L) x 38.8(W)	mm
Dot size	0.5(L) x 0.5(W)	mm
Dot pitch	0.52(L) x 0.52(W)	mm
Operating temp	-20~70	°C
Storage temp	-30~80	°C
Driving Method	1/ 65 DUTY, 1/9 BIAS, VOP=8.7V	
Viewing direction	6 O'CLOCK	
Display mode	FSTN	
Display type	TRANSFLECTIVE / POSITIVE	
Driver IC	SPLC501C	
Backlight	WHITE	

4. MODULE DRAWING

此处在LCD超出背光部分

BACK OF BACKLIGHT

DETAIL B

DISPLAY PATTREN

A---A

LED CIRCUIT DIAGRAM: 1#~4# (PCS)

NO	SYMBOL
1	/CS1
2	/RESET
3	A0
4	/WR
5	/RD
6	D0
7	D1
8	D2
9	D3
10	D4
11	D5
12	D6(SCL)
13	D7(S)
14	VDD
15	VSS
16	VOUT
17	CAP3N
18	CAP1P
19	CAP1N
20	CAP2N
21	CAP2P
22	V1
23	V2
24	V3
25	V4
26	V5

PIN CONNECTION

**NOTES:**

1. DISPLAY TYPE: FSTN, TRANSFLECTIVE/ POSITIVE.
2. DRIVE METHOD: 1/65DUTY, 1/9BIAS, VOP=8.7V, VDD=3.3V
3. VIEWING DIRECTION: 6 O'CLOCK.
4. IC DRIVER: SPLC501C.
5. OPERATING TEMP: -20°C ~ 70°C.
6. STORAGE TEMP: -30°C ~ 80°C.
7. BACKLIGHT: WHITE, I=80mA, VLED=2.9~3.5V.
8. "\*" CRITICAL DIMENSION.
9. ALL UNMARKED TOLERANCES: ±0.2.
10. RoHS COMPLIANT.

CUSTOMER APVL	DATE	TITLE	MODULE
DRAWN 刘顺祥	20101130	SCALE	
DFTG CHK		UNIT	mm
ENGR CHK		MODEL	GS-GG1286463FFWJ/R
APPROVAL		DWG NO	00
GENDA TECHNOLOGY LTD		PAGE	1/5

VERSION	MODIFY/CONTENT
---------	----------------

5. BLOCK DIAGRAM

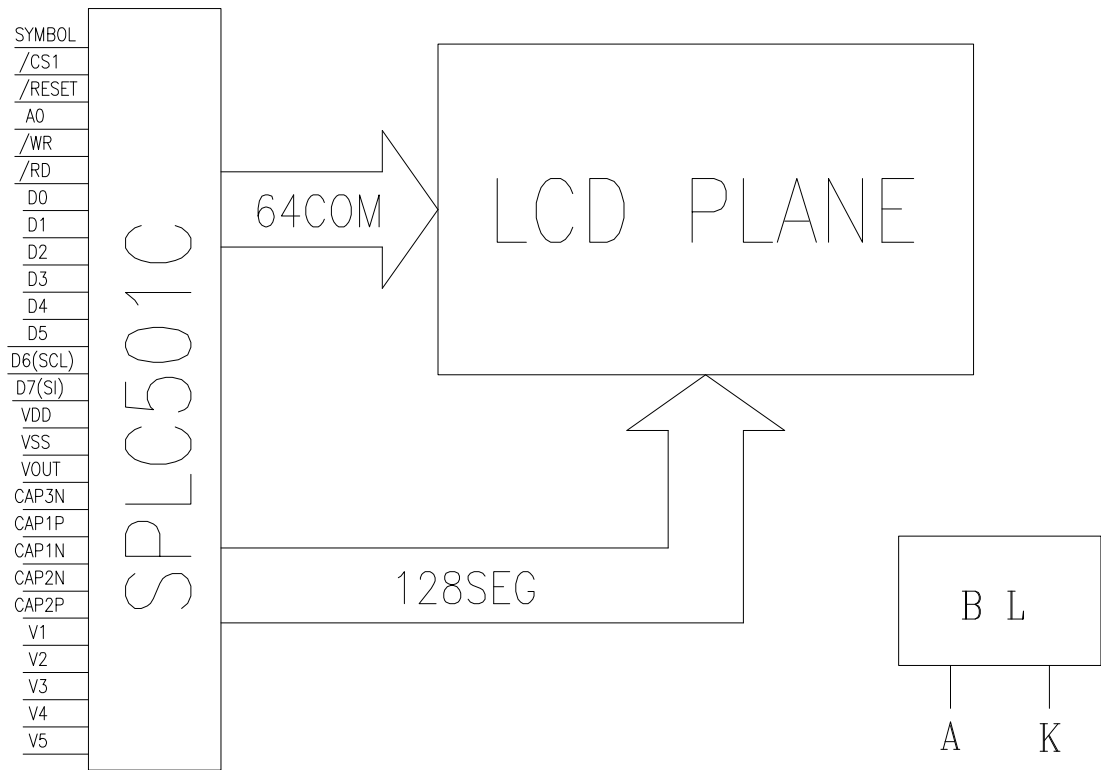

6. APPLICATION CIRCUIT

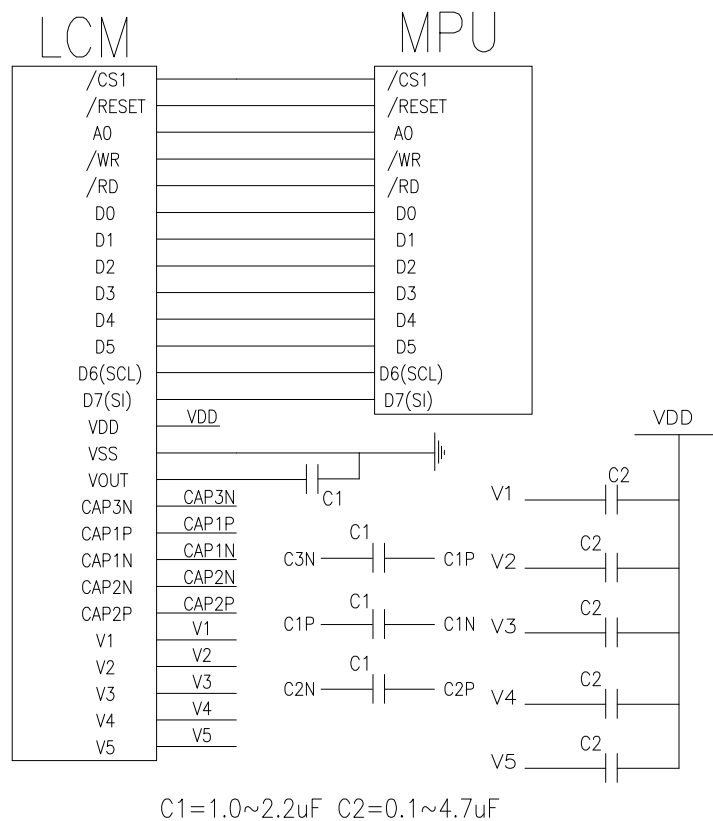

7.INTERFACE DESCRIPTION

No.	Symbol	Function
1	/CS	Chip select pin
2	/REST	External reset pin
3	A0	Select registers
4	/WR	Write signal
5	/RD	Read signal
6	D0	DATA BUS
7	D1	
8	D2	
9	D3	
10	D4	
11	D5	
12	D6(SCL)	
13	D7(SI)	
14	VDD	Power supply
15	VSS	Ground
16	VOUT	DC/DC voltage converter.
17	CAP3N	DC/DC voltage converter
18	CAP1P	
19	CAP1N	
20	CAP2N	
21	CAP2P	
22	V1	LCD driver supplies voltages
23	V2	
24	V3	
25	V4	
26	V5	

## 8. ELECTRICAL CHARACTERISTICS

ITEM	SYMBOL	CONDITIONS	STANDARD VALUE			UNIT
			MIN	TYP	MAX	
POWER SUPPLY VOLTAGE FOR <b>LCM</b>	VDD—VSS	Ta= +25℃	---	3.3	--	V
POWER SUPPLY FOR <b>LCD</b> DRIVING	V0—VSS	Ta= +25℃	8.5	8.7	8.9	V
POWER SUPPLY VOLTAGE FOR <b>LED</b>	VA-VK	Ta= +25℃	--	--	--	V
FORWARD CURRENT FOR <b>LED</b>	VA-VK	Ta= +25℃	--	--	--	MA
INPUT VOLTAGE “H” LEVEL	VIH	—	0.8VDD	—	VDD	V
INPUT VOLTAGE “L” LEVEL	VIL	—	VSS	—	0.2VDD	V
OUTPUT VOLTAGE “H” LEVEL	VOH	IOH=-0.5mA	0.8VDD	—	VDD	V
OUTPUT VOLTAGE “L” LEVEL	VOL	IOL=-0.5mA	VSS	—	0.2VDD	V

## 9. ABSOLUTE MAXIMUM RATINGS

Characteristic	Symbol	value	Unit
Power Supply Voltage	VDD	-0.3To 7.0	V
Power Supply Voltage(VDD Standard)	V5,VOUT	-12 To +0.3	V
Power Supply Voltage(VDD Standard)	V1,V2,V3,V4	V5To+0.3V	V
Operating temperature	TOPR	-20~70	℃
Storage temperature	TSTR	-30~80	℃

## 10. ELECTRO-OPTICAL CHARACTERISTICS

DUTY= 1/65 ; BIAS= 1/9

Item	Symbol	Measurement Temperature	Min	Type	Max	Unit	Remark	Note
Operating Voltage Range(LCD)	Vop	25℃	8.5	8.7	8.9	V		2
Vth	Vth1	25℃	0.7VDD	---	VDD	V		1
	Vth2	25℃	VSS	----	0.3VDD	V		
Response Time	Rise Time	25℃	----	200	----	ms		2
	Fall Time	25℃	----	250	----			
Contrast Ratio	Cr	25℃	3	5	---			3
Viewing Angle 视角 (6 o'clock)	θ 1	25℃	--	25	--	Deg	φ=0°	4
	θ 2	25℃	--	35	--		φ=180°	
	θ 3	25℃	--	30	--		φ=90°	
	θ 4	25℃	--	30	--		φ=270°	



Note1: Threshold Voltage:  $V_{th}$

Note2: Operating voltage and frequency:  $V_{op}$  Fr  
Response time  $T_r$ 、 $T_f$

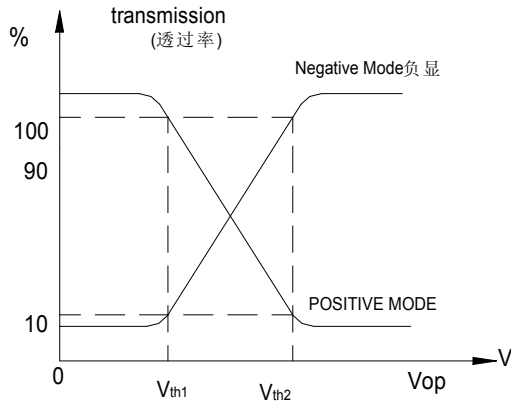

Note3: Contrast Ratio

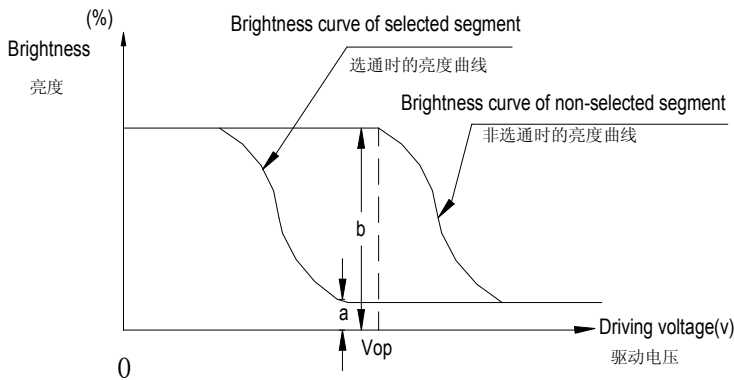

$$\text{Contrast Ratio} = \frac{\text{Brightness in OFF Static } b}{\text{Brightness in ON Static } a}$$

$\theta$  Viewing Angle  
 $\varnothing$  Direction Angle

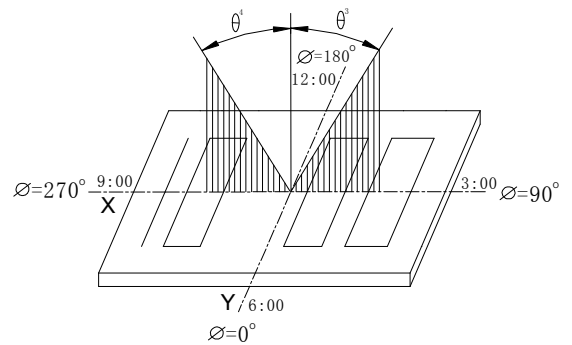
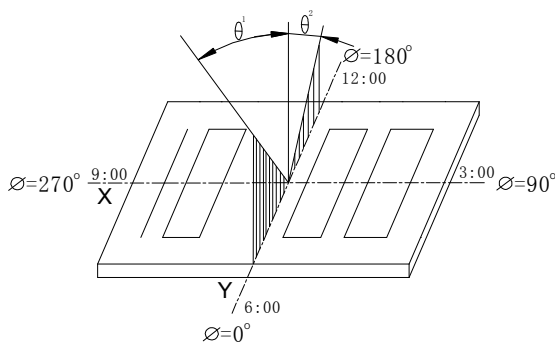

11. RELIABILITY OF LCD MODULE

ITEM	Test condition	Time
High temperature operating	70°C	72hours
Low temperature operating	-20°C	72hours
High temperature storage	80°C	72hours
Low temperature storage	-30°C	72hours
Temperature-humidity storage	40°C90%R. H.	96hours
Temperature cycling	-20°C to 25°C to 70°C to 25°C (30min/30min/30min30min)	10 cycle
Vibration Test at LCM Level	Freq 10-55Hz,Sweep rate:10-55-10 at 1 min, Sweep mode Linear Displacement: 1.5 mm p-p 1 hour each for X,Y,Z	30 Minutes
FPC of LCD bending Test	Try 20 times for bending FPC along the LCD as the bending radius is at least 0.5mm.	
<p>Criteria of judgment:</p> <ol style="list-style-type: none"> <li>1、 All of the segments shall not be blurred;</li> <li>2、 All segments shall be usually displayed;</li> </ol> <p>Judgment shall be made after exposure in room temperature condition for 2 hours;</p>		

12. AC Characteristics

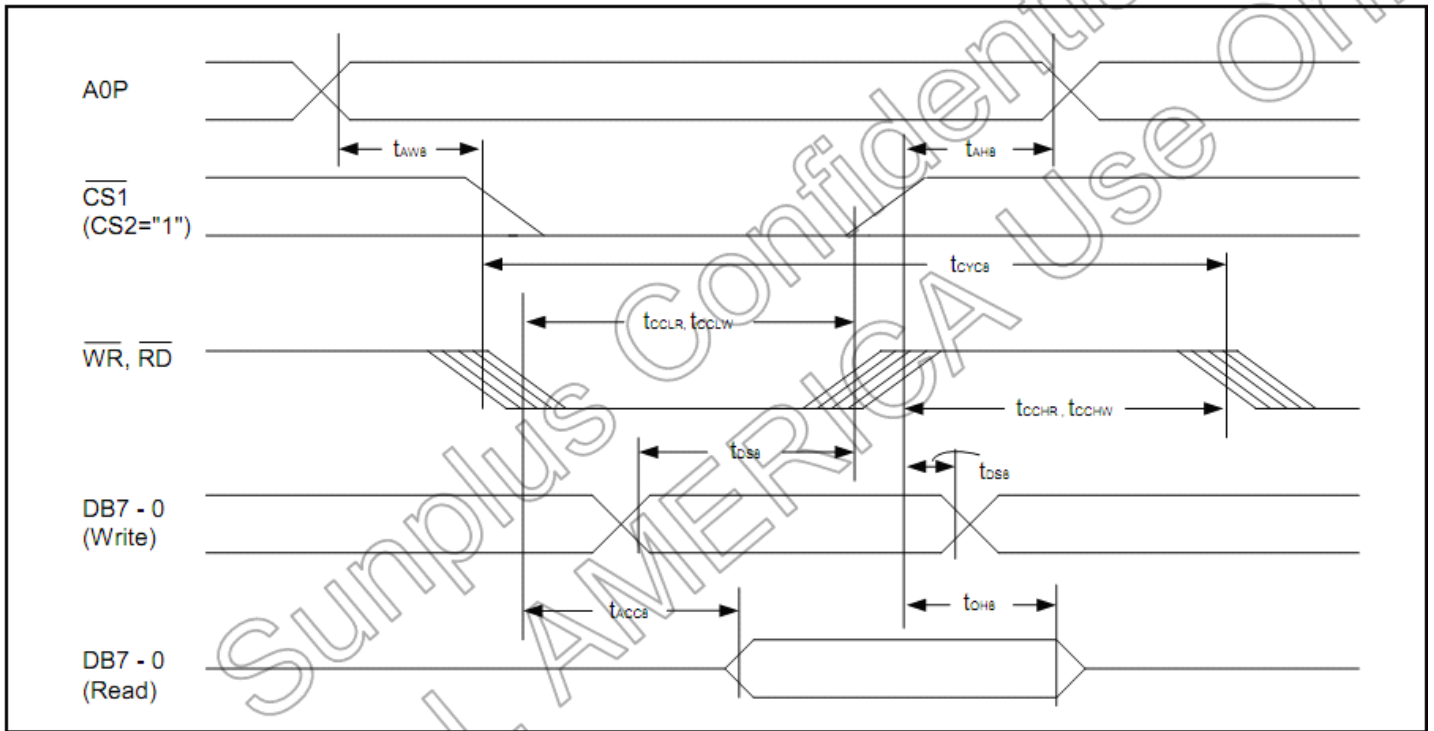

Item	Signal	Symbol	Condition	Rating		Units
				Min.	Max.	
Address hold time	A0P	t <sub>AHB</sub>		0	-	ns
Address setup time	A0P	t <sub>AWB</sub>		0	-	ns
System cycle time	A0P	t <sub>CYCB</sub>		300	-	ns
Control L pulse width ( WR )	WR	t <sub>OCLW</sub>		60	-	ns
Control L pulse width ( RD )	RD	t <sub>OCLR</sub>		120	-	ns
Control H pulse width ( WR )	WR	t <sub>OCHW</sub>		60	-	ns
Control H pulse width ( RD )	RD	t <sub>OCHR</sub>		60	-	ns
Data setup time	DB7 - 0	t <sub>DSE</sub>		40	-	ns
Address hold time		t <sub>DHE</sub>		15	-	ns
RD access time		t <sub>ACC8</sub>	C <sub>L</sub> = 100pF	-	140	ns
Output disable time		t <sub>O88</sub>		10	100	ns

13.COMMANDS TABLE

Command	Command Code										Function	
	A0P	RD	WR	DB7	DB6	DB5	DB4	DB3	DB2	DB1		DB0
1). Display ON/OFF	0	1	0	1	0	1	0	1	1	1	0	LCD display ON/OFF 0: OFF, 1: ON
2). Display start line set	0	1	0	0	1	Display start address					1	Sets the display RAM display start line address
3). Page address set	0	1	0	1	0	1	1	Page address				Sets the display RAM page address
4). Column address set upper bit	0	1	0	0	0	0	1	Most significant column address				Sets the most significant 4 bits of the display RAM column address.
Column address set lower bit	0	1	0	0	0	0	0	Least significant column address				Set the least significant 4 bits of the display RAM column address.
5). Status read	0	0	1	Status				0	0	0	0	Reads the status data
6). Display data write	1	1	0	Write data								Writes to the display RAM
7). Display data read	1	0	1	Read data								Reads from the display RAM
8). ADC select	0	1	0	1	0	1	0	0	0	0	0	Sets the display RAM address SEG output correspondence 0: normal, 1:reverse
9). Display normal/reverse	0	1	0	1	0	1	0	0	1	1	0	Sets the LCD display normal/ reverse 0: normal, 1:reverse
10). Display all points ON/OFF	0	1	0	1	0	1	0	0	1	0	0	Display all points 0: normal display 1: all points ON
11). LCD bias set	0	1	0	1	0	1	0	0	0	1	0	Sets the LCD driver voltage bias ratio SPLC501C.....0:1/9, 1:1/7
12). Read/modify/write	0	1	0	1	1	1	0	0	0	0	0	Column address increment At write: +1 At read: 0
13). End	0	1	0	1	1	1	0	1	1	1	0	Clear read/modify/write
14). Reset	0	1	0	1	1	1	0	0	0	1	0	Internal reset
15). Common output mode select	0	1	0	1	1	0	0	0	*	*	*	Select COM output scan direction 0: normal direction, 1: reverse direction
16). Power control set	0	1	0	0	0	1	0	1	Operating mode			Select internal power supply operating mode
17). V <sub>s</sub> voltage regulator internal resistor ratio set	0	1	0	0	0	1	0	0	Resistor ratio			Select internal resistor ratio (Rb/Ra) mode
18). Electronic volume mode set	0	1	0	1	0	0	0	0	0	0	1	Set the V <sub>s</sub> output voltage electronic volume register
Electronic volume register set	0	1	0	*	*	Electronic volume value						

19). Static indicator ON/OFF Static indicator Register set	0 1 0 0 1 0	1 0 1 0 1 1 0 0 * * * * * Mode	0: OFF, 1: ON 1 Set the flashing mode
20). Page Blink Page selection	0 1 0 0 1 0	1 1 0 1 0 1 0 1 P7 P6 P5 P4 P3 P2 P1 P0	P7 - 0: 1 - blinking page 0 - no blinking, normal display
21). Driving Mode Set Mode selection	0 1 0 0 1 0	1 1 0 1 0 0 1 0 D1 D0 0 0 0 0 0 0	Set the driving mode register Driving capability (D1, D0): (1,1)>(0,0)>(0,1)>(1,0)
22). Power saver			Display OFF and display all points ON compound command
23). NOP	0 1 0	1 1 1 0 0 0 1 1	Command for non-operation
24). Test	0 1 0	1 1 1 1 * * * * 1 1 0 1 0 1 0 0	Command for IC test. Do not use this command

**14.LCD MOUDLE QUALITY STANDARD**

**14.1** Inspection level:

Sampling procedure: General inspection levels II and single sampling plans for normal inspection of ISO2859.

Item	Indication	AQL
Major Nonconformity (MA)	Function	0.4
	Size	
Minor Nonconformity (MI)	Effects on LCD appearance but not on function	1.0

**14.2** Inspection condition:

**14.2.1** The inspection should be done under 40W fluorescent light and visual inspection distance is 30cm.

**14.2.2** Back-Lights or reflective boards should be adopted for inspecting transmissive LCDs.

**14.2.3** The visual direction should be viewing angle range

**14.2.4** This kind of situation will be judged qualificatory one that defecion of product in B area won't effect customer's assembly and product quality

**14.3** Definition of Application Zone:

A zone:Display area (VIEW)

B zone:Non-display area of the LCD

C zone:I/F area & Backlight area

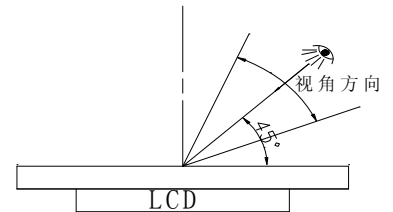
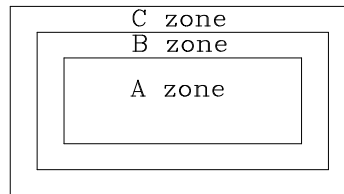

**14.4 LCD Appearance Standard:**

NO	Item		Specifications	Application zone		
				A	B	C
1	Glass	Chipping	There Should not be noticeable defect	○	○	-
2	Black spots/lines Dappled color	Black spots	$\varnothing < 0.15\text{mm}$ disregard $0.3\text{mm} \leq \varnothing$ n=0 $0.15 \leq \varnothing < 0.3$ n=3 $\varnothing$ :average diameter	○	-	-
		Black lines	(1) $W \leq 0.02\text{mm}$ disregard (2) $L \leq 3\text{mm}$ $W \leq 0.03\text{mm}$ (3) $L \leq 2.5\text{mm}$ $W \leq 0.05\text{mm}$ (2)+(3) $\leq 4\text{pcs}$ (4) $W > 0.05\text{mm}$ ...Refer to the round specification	○	-	-
		Dappled color	There should not be distinct dappled color	○	-	-
3	Contrast spots		$\varnothing \leq 0.2\text{mm}$ disregard $0.2\text{mm} < \varnothing \leq 1.0\text{mm}$ n $\leq 1$ $1.0\text{mm} < \varnothing$ n=0 $\varnothing$ :average diameter	○	-	-
4	Polarizer	Bubbles	$\varnothing \leq 0.2\text{mm}$ disregard $0.3\text{mm} < \varnothing \leq 0.5\text{mm}$ n $\leq 1$ $0.2\text{mm} < \varnothing \leq 0.3\text{mm}$ n=2 $\varnothing$ :average diameter	○	-	-
		Peeling	The polarizer should not peel	○	-	-
		Scratches	There should not be distinct scratch	○	-	-
		Protective film	Bubbles are acceptable	○	○	-

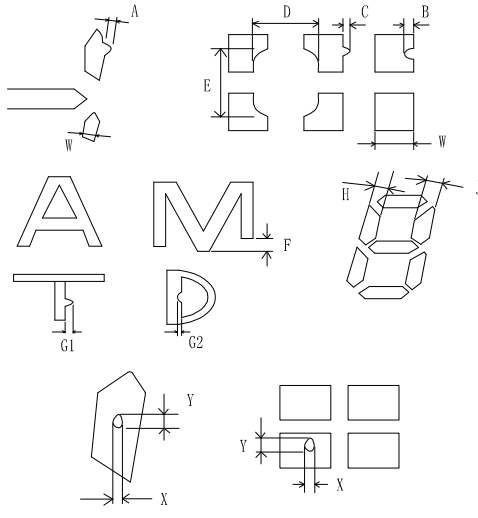
5	LCD pattern	Display pattern	There should not be distinct deformation in each segment character or dot on visual inspection	○	-	-
		Deformation(projection notch or pinhole) W: pattern width in the spec sheet	 <p> <math>A \leq 0.2</math> and <math>A \leq (1/3)W</math>  <math>B \leq 0.2</math> and <math>A \leq (1/2)W</math>            C: pattern should not touch to the adjacent dots.  <math>(D+E)/2 \leq 0.2</math> <math>F \leq 0.25</math>  <math>G1 \leq 0.15</math> and <math>G1 \leq (1/3)W</math>  <math>G2 \leq 0.15</math> and <math>G2 \leq (1/2)W</math>  <math> H-J  \leq 0.25</math> <math>(X+Y)/2 \leq 0.2</math>            Maximum quantity of defects(deformation notch and pinhole)                less than 1 per dot                less than 1 per segment                less than 5 per LCD            More than half of the area of each dot should be remained            Defects smaller than 0.1 shall be disregarded         </p>			
		Open Short	There should not be open or short	○	○	-
6	Surface of the LCD	Dust Stains or defects	Round $\varnothing < 0.3\text{mm}$ disregard $0.3\text{mm} \leq \varnothing$ $n=0$ $\varnothing$ : average diameter Filamentous 1) $W \leq 0.02\text{mm}$ diameter 2) $L \leq 2.5\text{mm}$ $W \leq 0.03\text{mm}$ 3) $L \leq 1.5\text{mm}$ $W \leq 0.5\text{mm}$ 2)+3) $\leq 6\text{pcs}$ 4) $W > 0.05\text{mm}$ ...Refer to the round specification Dust that can be blown away by airblow and stains that can be Wiped off lightly by cloth shall be disregarded	-	-	○

**14.5 PCB/COB Appearance Standard:**

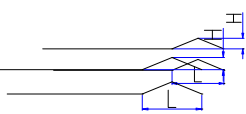
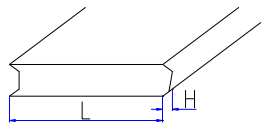
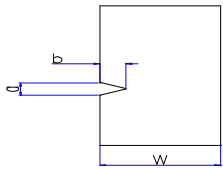
1	PCB deformity 	L	H		
		$\leq 6.0\text{mm}$	$\leq 1.5\text{mm}$	Accept	
		$< 6.0\text{mm}$	$\leq 1.5\text{mm}$	Reject	MIN
		$< 6.0\text{mm}$	$> 1.5\text{mm}$	Reject	MIN
		$> 6.0\text{mm}$	$> 1.5\text{mm}$	Reject	MIN
2	Deformity at PCB edge,damage circuit			Reject	MAJ
3	Convex at PCB edge 	L	H		
		$\leq 6.0\text{mm}$	$\leq 1.5\text{mm}$	Accept	MIN
		$< 6.0\text{mm}$	$\leq 1.5\text{mm}$	Reject	MIN
		$< 6.0\text{mm}$	$> 1.5\text{mm}$	Reject	MIN
		$> 6.0\text{mm}$	$> 1.5\text{mm}$	Reject	MIN
4	Damage excess 2x2mm at the PCB corner			Reject	MIN
5	Scratch on PCB surface			See sample	MIN
6	Scratch on PCB coat/leakage coat on PCB surface			Reject	MAJ
7	Open circuit			Reject	MAJ
8	PCB PTH open			Reject	MAJ
9	Repair PCB PTH		QTY $\leq 2\text{PCS}$	Accept	
			QTY $\geq 3\text{PCS}$	Reject	MAJ
10	Color different from one side to another side			Reject	MIN
11	Repaired solder mask area		$\leq 30\text{m}^2$	Accept	
			$\geq 30\text{m}^2$	Reject	MIN
12	Scratch circuit,damage Circuit 		$a \leq 1/2w$ or $b < w$	Accept	
			$a > 1/2w$ or $b > w$		
				Reject	

**14.6 Bezel Appearance Standard:**

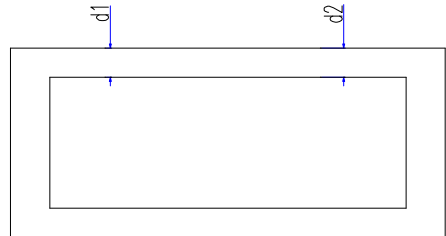

1	Wrong Materials				MAJ	
2	Incorrect dimension				MAJ	
3	Bezel broken				MAJ	
4	Rust on Bezel				MAJ	
5	Hole or dirty on oil Paint surface	Top surface	Size	cm <sup>2</sup> /per		
			$\phi \leq 0.3$	2	Accept	
			$0.3 < \phi \leq 0.5$	1	Accept	
		Side	$\phi > 0.5$	0	Reject	MIN
			$\phi \leq 0.5$	2	Accept	
			$0.5 < \phi \leq 0.8$	1	Accept	
6	Bezel bow or twist		$h \leq 0.01\text{mm/mm}$	Accept		
7			$h > 0.01\text{mm/mm}$	Reject	MIN	
			$D1-d2 \leq \text{tolerance}$	Accept		
			$D1-d2 > \text{tolerance}$	Reject	MIN	
8	Scratch on bezel	Face	Accept QTY			

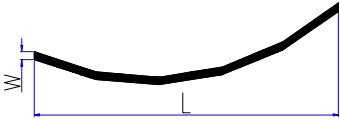
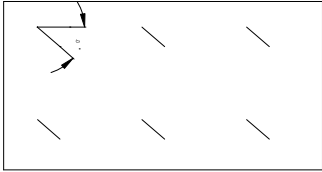
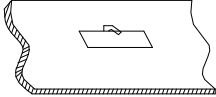

	L	W	Not defined	See Sample
	-	$W \leq 0.15$		
	$L \leq 3$	$W \leq 0.20$	2	
	$L \leq 2$	$W \leq 0.3$	2	
	-	$W > 0.3$		
	side		Accept QTY	
	L	W		See Sample
	-	$W \leq 0.2$	except	
$L \leq 3$	$W \leq 0.25$	2		
$L \leq 2$	$W \leq 0.3$	2		
9	Twist angle		Accept	
10	Void gap between bezel and PCB		Reject	MIN
11	Bezel clip incorrectly	 NG	Reject	MIN

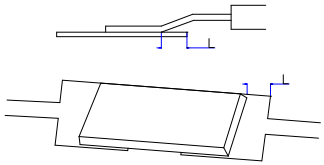
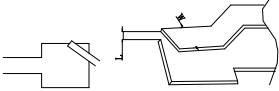
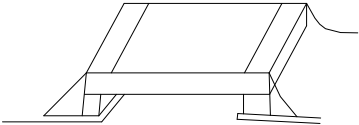
**14.7 Solder Appearance Standard:**

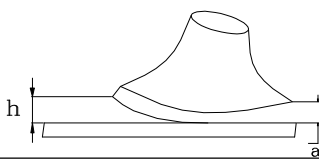
1	Wrong component		Reject	MAJ
2	Broken component		Reject	MAJ
3	Mis alignment 	Component legs extend beyond the Legs > pad distance (w) on solder area > W <sup>2</sup>	Accept	
		Component legs extend beyond the pad and Legs > pad distance (w) on solder area > W <sup>2</sup>	Reject	MIN
3	Component Offset 	Solder legs offset distance $L < \text{solder legs } 1/4W$	Accept	
		Solder legs offset $L > 1/4W$	Reject	MIN
4	Component assembly defect 		Reject	MIN
5	CHIP components hoist $\leq 0.5\text{mm}$		Accept	
6	CHIP components hoist $> 0.5\text{mm}$		Reject	MIN
7	Components hoist	$h \leq 2.0\text{mm}$	Accept	
		$h > 2.0\text{mm}$	Reject	MIN
8	Switch (socket) hoist	$h \leq 0.5\text{mm}$	Accept	
		$h > 0.5\text{mm}$	Reject	MIN
9	Components cold solder or incomplete solder		Reject	MAJ

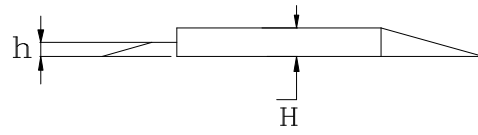
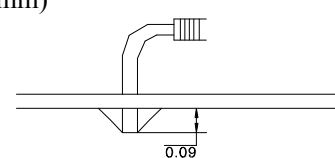
10	Solder PAD tilt up but height (h) less than Solder PAD thickness (a) Solder PAD thickness (a)		Accept	
11	Excess solder above components		Reject	MIN
12	Insufficient solder below components or less than diameter		Reject	MIN
13	Solder area less than soldering PAD Area by 2/3		Reject	MIN
14	Trimmed pin length beyond 0.09inch(2.3mm)		Reject	MIN

**14.8 Cable Dimensions and Backlight Appearance Standard:**

NO	Item	Specifications	Application zone		
			A	B	C
1	I/F cable	Open Short	-	-	○
		Scratches	-	-	○
		Peeling	-	-	○
		Sharp bending	-	-	○
2	Dimensions	Outline dimensions Display area	○	○	○
3	Backlight	Dust Stains or scratches	-	-	○

## 15. HANDLING PRECAUTIONS

### 15.1 CAUTION OF LCD HANDLING & CLEANING

Use soft cloth with solvent (recommended below) to clean Isopropyl alcohol, ethyl alcohol, trichlorotrifluoroethane  
Do not wipe the display surface with dry or hard materials that will damage the polarizer surface. Do not use the following solvent:

-water, ketone, aromatics

### 15.2 CAUTION AGAINST STATIC CHARGE

The LCD modules use CMOS LSI drivers, so customers are recommended that any unused input terminal would be connected to VDD or VSS, do not input any signals before power is turned on, and ground your body, work/assembly areas, assembly equipment to protect against static electricity. Remove the protective film slowly and, if possible, under ESD control device like ion blower and humidity of working room should be kept over 50%RH to reduce risk of static charge.

### 15.3 PACKAGING

Avoid intense shock and falls from a height and do not operate or store them exposed direct to sunshine or high temperature/humidity.

### 15.4 CAUTION FOR OPERATION

It is an indispensable condition to drive LCD's within the specified voltage limit since the higher voltage than the limit causes the shorter LCD life. The use of direct current drive should be avoided because an electrochemical action due to direct current causes LCD's undesirable deterioration. Response time will be extremely delayed at low temperature, and LCD's show dark color at high temperature. However those phenomena do not mean malfunction or out of order with LCD's. Some font will be abnormally displayed when the display area is pushed hard during operation. But it resumes normal condition after turning off once.

### 15.5 SAFETY

For crash damaged or unnecessary LCD's, it is recommended to wash off liquid crystal by either of solvents such as acetone and ethanol and should be burned up later. When any liquid leaked out of a damaged glass cell comes in contact with your hands, wash it off with soap and water.

**16. PACKING SPECIFICATIONS**

A. Put LCM into package

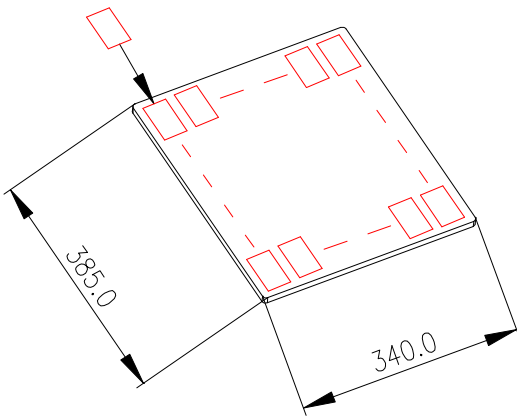

B. Then put 1pcs Soft-thing.

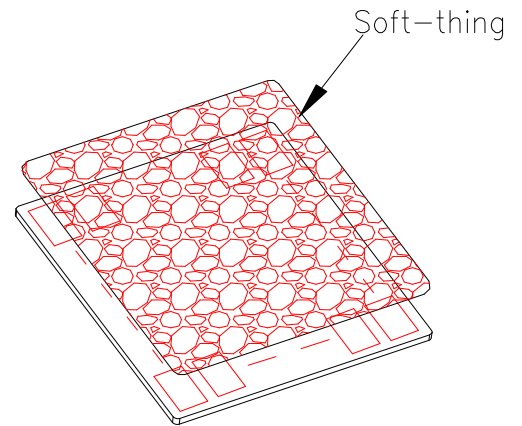

D. Put the "C" into the long cardboard.

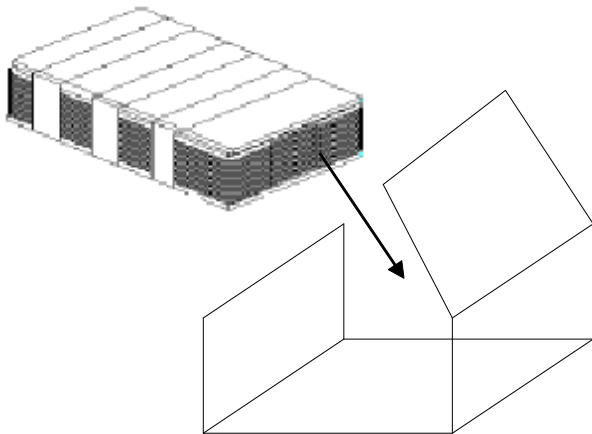

C. Every group between bubble flakes

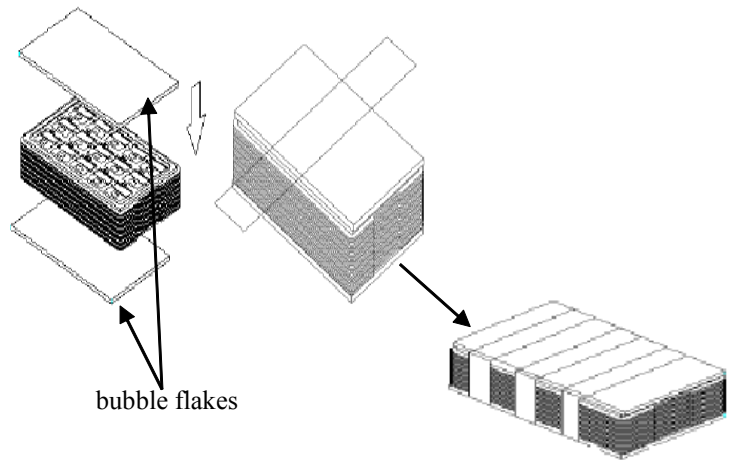

E. Put "D" into the carton box

