

GS1185L

3A Low Dropout Voltage Regulator

Product Description

The GS1185L is a low drop voltage regulator able to provide up to 3A output current. The dropout voltage of the device is guaranteed at a maximum 1.3V at the maximum output current, decreasing at lower loads.

The GS1185L is pin compatible with older 3-terminal adjustable regulators, but has better performances in term of drop and output tolerance.

Features

- Three Terminal Adjustable or Fixed Output Voltages 1.5V, 1.8V, 2.5V, 3.3V and 5V
- Guaranteed Output Current up to 3A
- Typical Dropout 1.3V (at 3A)
- Output Tolerance: $\pm 2\%$ at 25 °C
- Wide Operating Temperature Range: -40°C to 125 °C
- Ultra low current consumption (0.35mA typ.)
- Ultra low Adjustment Current (6 μ A typ.)
- Package Available: TO-220, TO-263, TO-252, and SOT-223
- Suitable for use with MLCC capacitors
- RoHS Compliant, 100%Pb & Halogen Free

Applications

- Post Regulators for Switching Supply
- Battery-Powered Circuitry
- Low Voltage Logic Supplies
- High efficiency linear regulators
- Adjustable power supply

Block Diagram

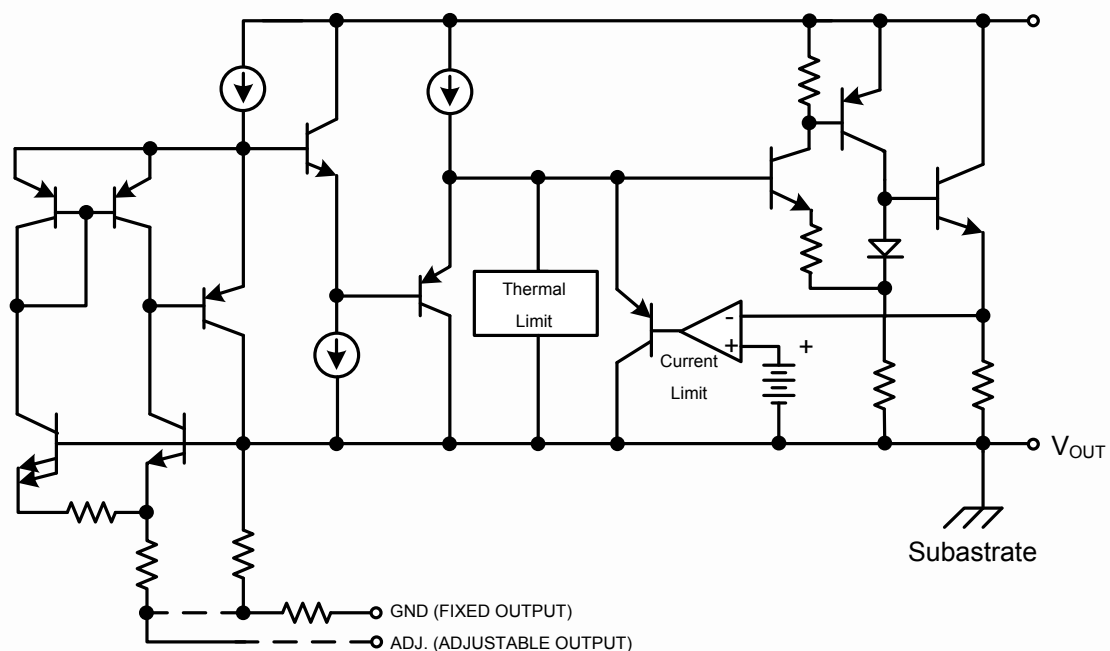

Packages & Pin Assignments

GS1185LT (TO-220)		GS1185LM (TO-263)		GS1185LD (TO-252)		GS1185LX (SOT-223)	
1	GND/ADJ	1	GND/ADJ	1	GND/ADJ	1	GND/ADJ
2	V _{OUT}	2	V _{OUT}	2	V _{OUT}	2	V _{OUT}
3	V _{IN}	3	V _{IN}	3	V _{IN}	3	V _{IN}

Ordering Information

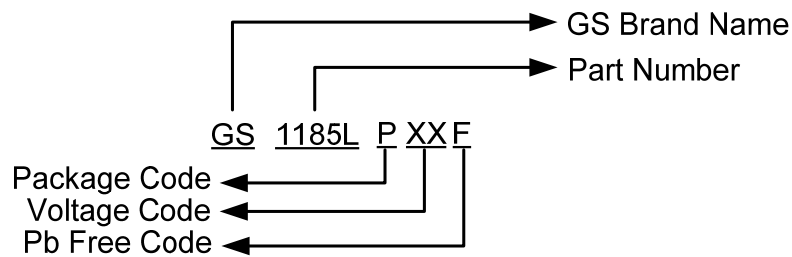

TO-220	TO-263	TO-252	SOT-223	Output
GS1185LT	GS1185LM	GS1185LD	GS1185LX	ADJ
GS1185LT15	GS1185LM15	GS1185LD15	GS1185LX15	1.5V
GS1185LT18	GS1185LM18	GS1185LD18	GS1185LX18	1.8V
GS1185LT25	GS1185LM25	GS1185LD25	GS1185LX25	2.5V
GS1185LT33	GS1185LM33	GS1185LD33	GS1185LX33	3.3V
GS1185LT50	GS1185LM50	GS1185LD50	GS1185LX50	5.0V

Adjustable Version does not need Voltage Code.

Marking Information

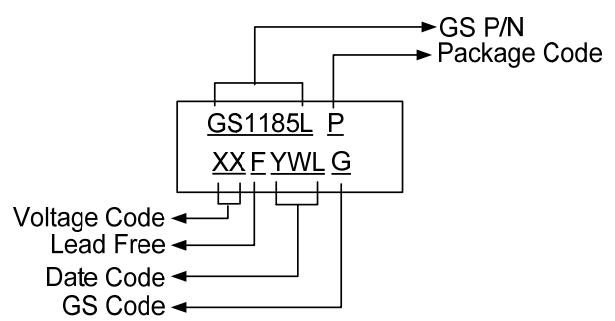
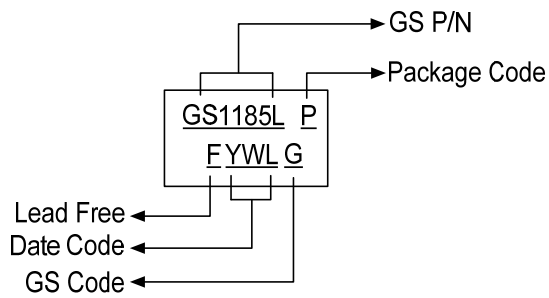

Absolute Maximum Ratings

Symbol	Parameter	Maximum Ratings	Units
V_{IN}	Input Voltage	15	V
θ_{JC}	Thermal Resistance (Junction to Case)	TO-220	3
		TO-263	3
		TO-252	5
		SOT-223	8
θ_{JA}	Thermal Resistance (Junction to Ambient)	TO-220	62.5
		TO-263	62.5
		TO-252	104
		SOT-223	138
P_D	Internal Power Dissipation	TO-220	2
		TO-263	2
		TO-252	1.2
		SOT-223	0.9
T_J	Operating Junction Temperature	-40 to 125	°C
T_{STG}	Storage Range	-65 to 150	°C
T_{LEAD}	Lead Temperature (Soldering 10sec)	300	°C

Caution: Stress above the listed absolute maximum rating may cause permanent damage to the device

Electrical Characteristics

$I_{OUT} = 0$ mA, and $T_J = +25^\circ\text{C}$, unless otherwise noted

Parameter	Device	Conditions	Min	Typ	Max	Units
Reference Voltage ₍₁₎	GS1185L	$V_{IN}=2.75\text{V}$, $I_o=10\text{mA}$	1.238	1.250	1.263	V
		$V_{IN}=2.7$ to 7V , $I_o=10\text{mA}$ to 3A	1.225	1.250	1.275	V
Output Voltage	GS1185L-1.5	$V_{IN}=4.0\text{V}$ $V_{IN}=3.0\text{V}$, $I_o=0\text{mA}$ to 3A	1.485 1.470	1.500 1.500	1.515 1.530	V V
	GS1185L-1.8	$V_{IN}=4.3\text{V}$ $V_{IN}=3.3\text{V}$, $I_o=0\text{mA}$ to 3A	1.782 1.764	1.800 1.800	1.818 1.836	V V
	GS1185L-2.5	$V_{IN}=5.0\text{V}$ $V_{IN}=4.0\text{V}$, $I_o=0\text{mA}$ to 3A	2.475 2.450	2.500 2.500	2.525 2.550	V V
	GS1185L-3.3	$V_{IN}=5.8\text{V}$ $V_{IN}=4.8\text{V}$, $I_o=0\text{mA}$ to 3A	3.267 3.234	3.300 3.300	3.333 3.366	V V
	GS1185L-5.0	$V_{IN}=7.5\text{V}$ $V_{IN}=6.5\text{V}$, $I_o=0\text{mA}$ to 3A	4.950 4.900	5.000 5.000	5.050 5.100	V V
Line Regulation ₍₁₎	All	$I_o = 10\text{mA}$ $(V_o+1.5\text{V}) \leq V_{IN} \leq 7\text{V}$		0.04	0.2	%
Load Regulation ₍₁₎	All	$V_{IN}=V_o+2.5\text{V}$, $I_o=0\text{mA}$ to 3A		0.08	0.4	%
Dropout Voltage ($V_{IN} - V_{OUT}$) _{(1),(3)}	All	ΔV_{OUT} , $\Delta V_{REF} = 1\%$, $I_{OUT} = 3\text{A}$		1.1	1.3	V
Current Limit ₍₁₎	All		3	5	6.5	A
Quiescent Current	All	$V_{IN} = 5\text{V}$		0.35	1	mA
Ripple Rejection ₍₁₎	All	$f = 120\text{Hz}$, $C_{OUT} = 25\mu\text{F}$, $I_{OUT} = 3\text{A}$, $(V_{IN}-V_{OUT}) = 3\text{V}$, $C_{ADJ} = 25\mu\text{F}$	60	75		dB
Adjust Pin Current ₍₁₎	GS1185L			6.0	12	μA
Minimum Load Current				0.35	1	mA
Temperature Stability				0.5	1	%
Long Term Stability		$T_A = 25^\circ\text{C}$, 1000Hrs		0.03	1	%
Thermal shutdown			130	150	170	$^\circ\text{C}$
Current Limit Response Time	All			10	100	μs
Pulse Current		Pulse Time=100us			13	A

Note 1: For GS1185L(adjustable) $V_{ADJ}=0\text{V}$

Note 2: For the adjustable device the minimum load current is the minimum current required to maintain regulation. Normally the current in the resistor divider used to set the output voltage is selected to meet the minimum load current requirement.

Note 3: The specification represents the minimum input/output voltage required to maintain 1% regulation.

Typical Applications

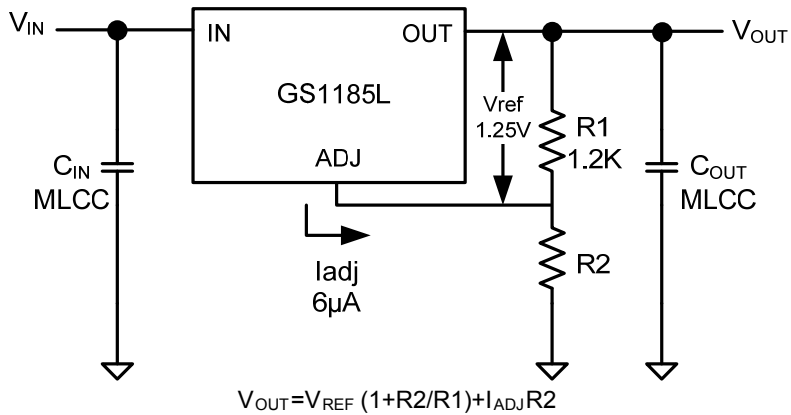

Figure1. Adjustable Voltage Regulator

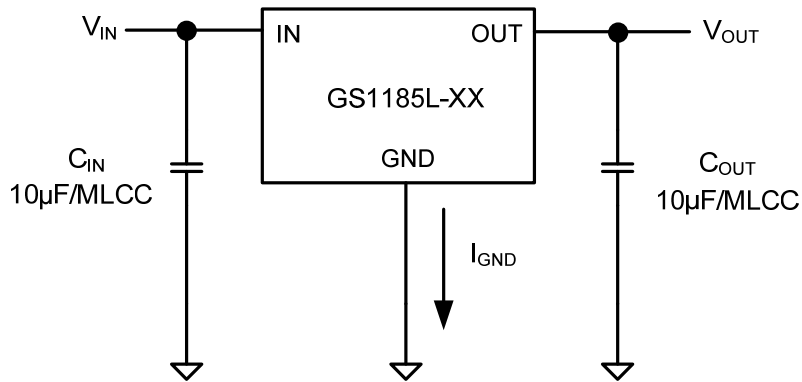
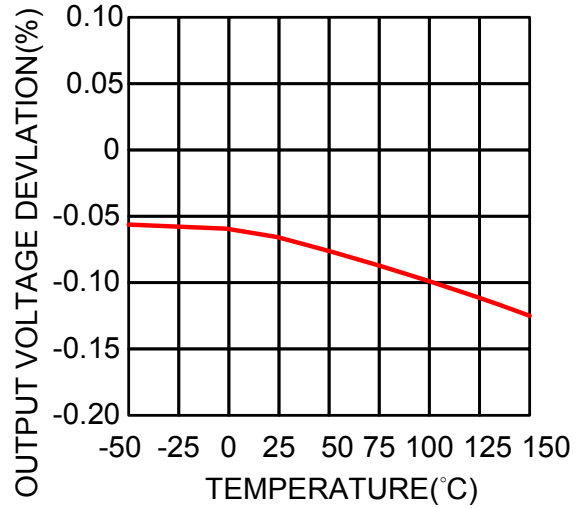
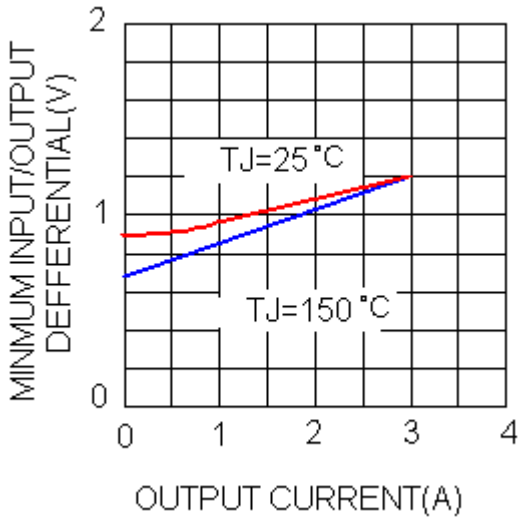

Figure2. Fixed Voltage Regulator

Typical Performance Characteristics

Dropt Voltage

Load Regulation



Typical Performance Characteristics(Continue)

Temperature Stability

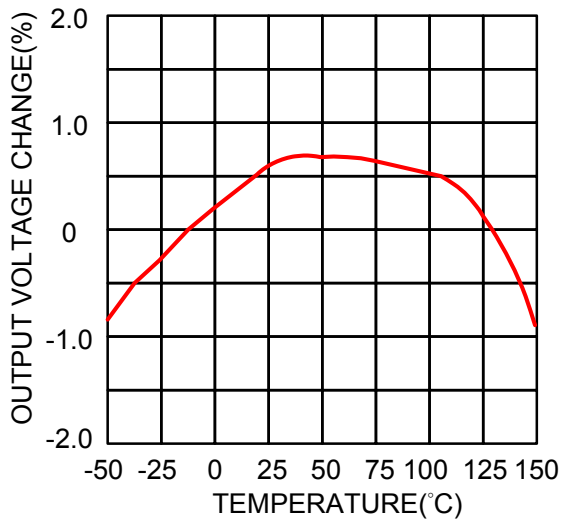

Ripple Rejection vs. Current

Ripple Rejection

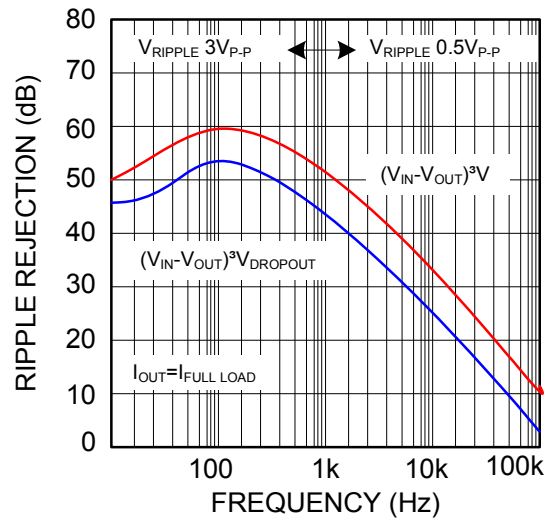

Short-Circuit Current

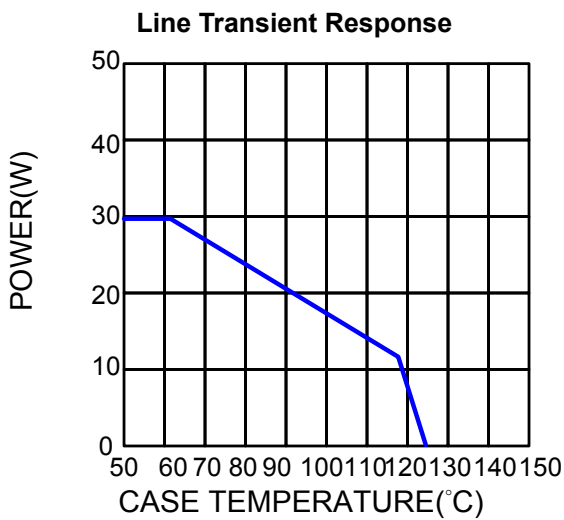
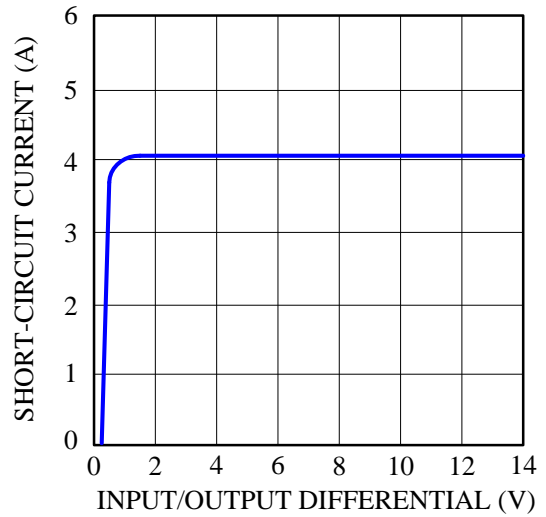
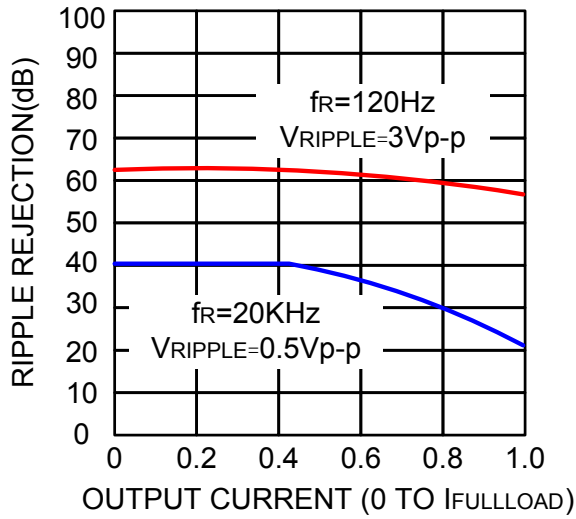

*AS LIMITED BY MAXIMUM JUNCTION TEMPERATURE

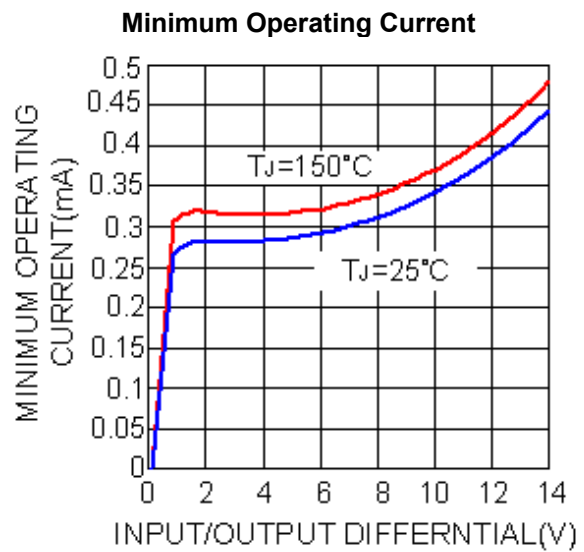

Typical Performance Characteristics(Continue)

Adjust Pin Current

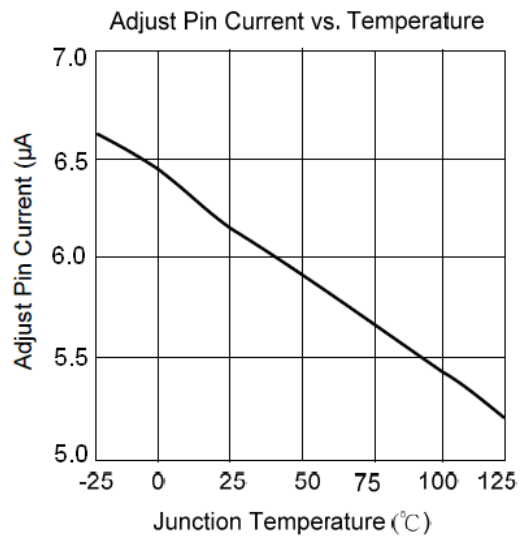

Package Dimension

TO-220 PLASTIC PACKAGE

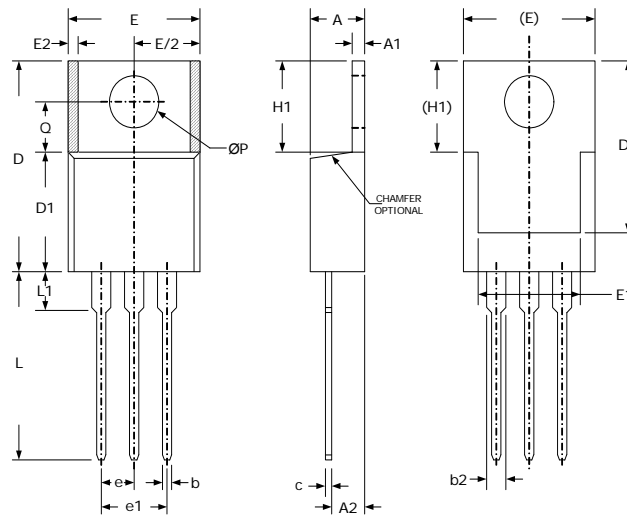

Dimensions

SYMBOL	Millimeters		Inches	
	MIN	MAX	MIN	MAX
A	3.56	4.83	.140	.190
A1	0.51	1.40	.020	.055
A2	2.03	2.92	.080	.115
b	0.38	1.02	.015	.040
b2	1.14	1.78	.045	.070
C	0.36	0.61	.014	.024
D	14.2	16.5	.560	.650
D1	8.38	9.02	.330	.355
D2	12.19	12.88	.480	.507
E	9.65	10.67	.380	.420
E1	6.86	8.89	.270	.350
E2	-	0.76	-	.030
e	2.54 (TYP)		.100 (TYP)	
e1	5.08 (TYP)		.200 (TYP)	
H1	5.84	6.86	.230	.270
L	12.70	14.73	.500	.580
L1	-	6.35	-	.250
ØP	3.53	4.09	.139	.161
Q	2.54	3.43	.100	.135

TO-263 PLASTIC PACKAGE

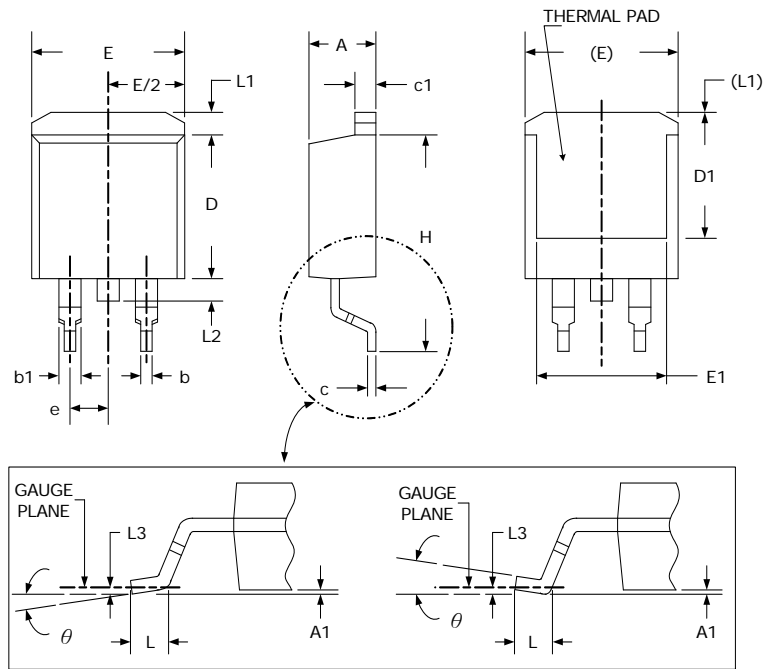

Dimensions

SYMBOL	Millimeters		Inches	
	MIN	MAX	MIN	MAX
A	4.06	4.83	.160	.190
A1	0	0.25	.000	.010
b	0.51	0.99	.020	.039
b1	1.14	1.78	.045	.070
c	0.38	0.74	.015	.029
c1	1.14	1.65	.045	.065
D	8.38	9.65	.330	.380
D1	6.86	-	.270	-
E	9.65	10.67	.380	.420
E1	6.22	-	.245	-
e	2.54 (TYP)		.100 (TYP)	
H	14.61	15.88	.575	.625
L	1.78	2.79	.070	.110
L1	-	1.68	-	.066
L2	-	1.78	-	.070
L3	0.25 (TYP)		.010 (TYP)	
θ	0°	8°	0°	8°

TO-252 PLASTIC PACKAGE

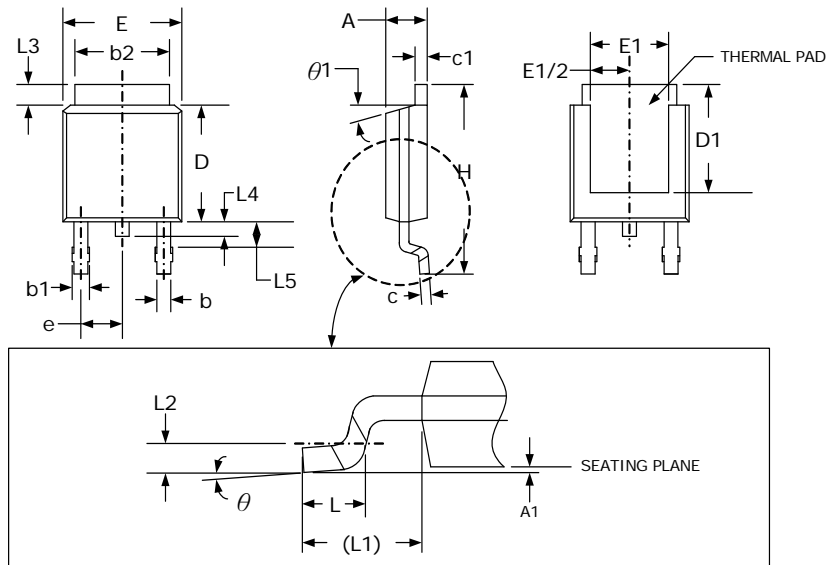

Dimensions

SYMBOL	Millimeters		Inches	
	MIN	MAX	MIN	MAX
A	2.18	2.39	.086	.094
A1	-	0.13	-	.005
b	0.64	0.89	.025	.035
b1	0.76	1.14	.030	.045
b2	4.95	5.46	.195	.215
C	0.46	0.61	.018	.024
C1	0.46	0.89	.018	.035
D	5.97	6.22	.235	.245
D1	5.21	-	.205	-
E	6.35	6.73	.250	.265
E1	4.32	-	.170	-
e	2.29 (TYP)		.090 (TYP)	
H	9.40	10.41	.370	.410
L	1.40	1.78	.055	.070
L1	2.74 (TYP)		.108 (TYP)	
L2	0.51 (TYP)		.020 (TYP)	
L3	0.89	1.27	.035	.050
L4	-	1.02	-	.040
L5	1.14	1.52	.045	.060
θ	0°	10°	0°	10°
θ1	0°	15°	0°	15°

SOT-223-3L PLASTIC PACKAGE

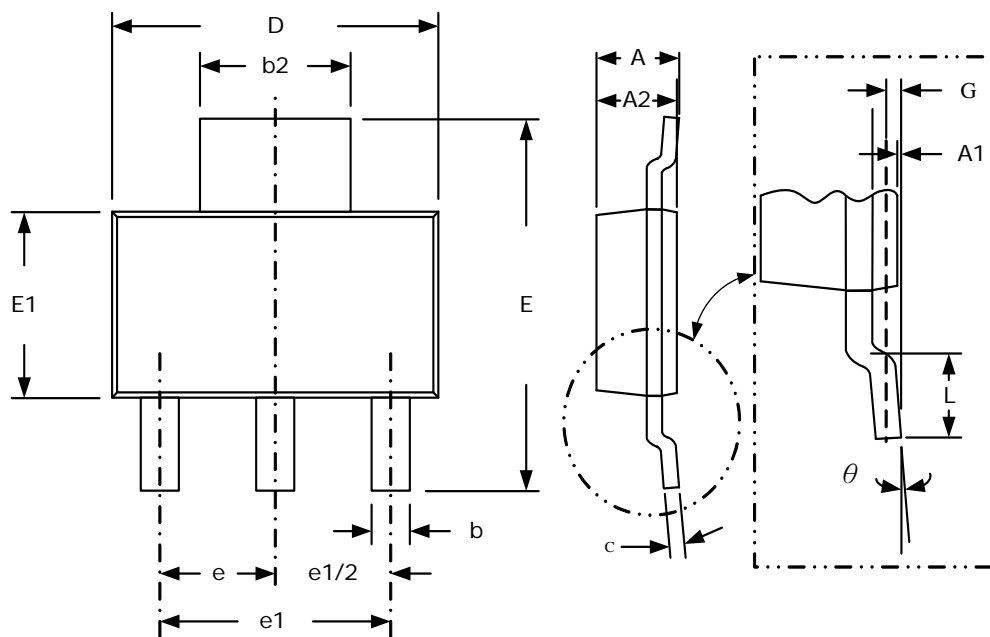











Dimensions

SYMBOL	Millimeters		Inches	
	MIN	MAX	MIN	MAX
A	-	1.80	-	.071
A1	0.02	0.10	.001	.004
A2	1.55	1.65	.061	.065
b	0.66	0.84	.026	.033
b2	2.90	3.10	.114	.122
c	0.23	0.33	.009	.013
D	6.30	6.70	.248	.264
E	6.70	7.30	.264	.288
E1	3.30	3.70	.130	.146
e	2.30 (TYP)		.091 (TYP)	
e1	4.60 (TYP)		.181 (TYP)	
L	0.90	-	.035	-
G	0.25 (TYP)		.010 (TYP)	
θ	0°	8°	0°	8°

NOTICE

Information furnished is believed to be accurate and reliable. However Globaltech Semiconductor assumes no responsibility for the consequences of use of such information nor for any infringement of patents or other rights of third parties, which may result from its use. No license is granted by implication or otherwise under any patent or patent rights of Globaltech Semiconductor. Specifications mentioned in this publication are subject to change without notice. This publication supersedes and replaces all information without express written approval of Globaltech Semiconductor.

CONTACT US

GS Headquarter	
	4F.,No.43-1,Lane11,Sec.6,Minquan E.Rd Neihu District Taipei City 114, Taiwan (R.O.C)
	886-2-2657-9980
	886-2-2657-3630
	sales_twn@gs-power.com
Wu-Xi Branch	
	No.21 Changjiang Rd., WND, Wuxi, Jiangsu, China (INFO. & TECH. Science Park Building A 210 Room)
	86-510-85217051
	86-510-85211238
	sales_cn@gs-power.com
RD Division	
	824 Bolton Drive Milpitas. CA. 95035
	1-408-457-0587