

52kHz 3A Step-Down Voltage Regulator

Product Description

The GS2576 series of regulators are monolithic integrated circuits that provide all the active functions for a step-down switching regulator, capable of driving 3A load with excellent line and load regulation. This device is available in fixed output voltages of 3.3V, 5V and an adjustable output version.

Requiring a minimum number of external components, these regulators are simple to use and include internal frequency compensation and a fixed-frequency oscillator.

The GS2576 series offers a high-efficiency replacement for popular three-terminal linear regulators. It substantially reduces the size of the heat sink, and in some cases no heat sink is required.

A standard series of inductors optimized for use with the GS2576. This feature greatly simplifies the design of switch-mode power supplies.

Other features include a guaranteed $\pm 4\%$ tolerance on output voltage within specified input voltages and output load conditions, and $\pm 10\%$ on the oscillator frequency. External shutdown is included, featuring 50 μ A (typical) standby current. The output switch includes cycle-by-cycle current limiting, as well as thermal shutdown for full protection under fault conditions..

Features

- 3.3V, 5V and adjustable output versions
- Adjustable version output voltage range, 1.23V to 37V
- $\pm 4\%$ max over line and load conditions
- Guaranteed 3A output current
- 40V wide input voltage range
- Requires only 4 external components
- 52 kHz fixed frequency oscillator
- TTL shutdown capability, low power standby mode
- High efficiency
- Uses readily available standard inductors
- Thermal shutdown and current limit protection

Applications

- Simple high-efficiency step-down regulator
- On-card switching regulators
- Positive to negative converter
- Efficient pre-regulator for linear regulators

Block Diagram

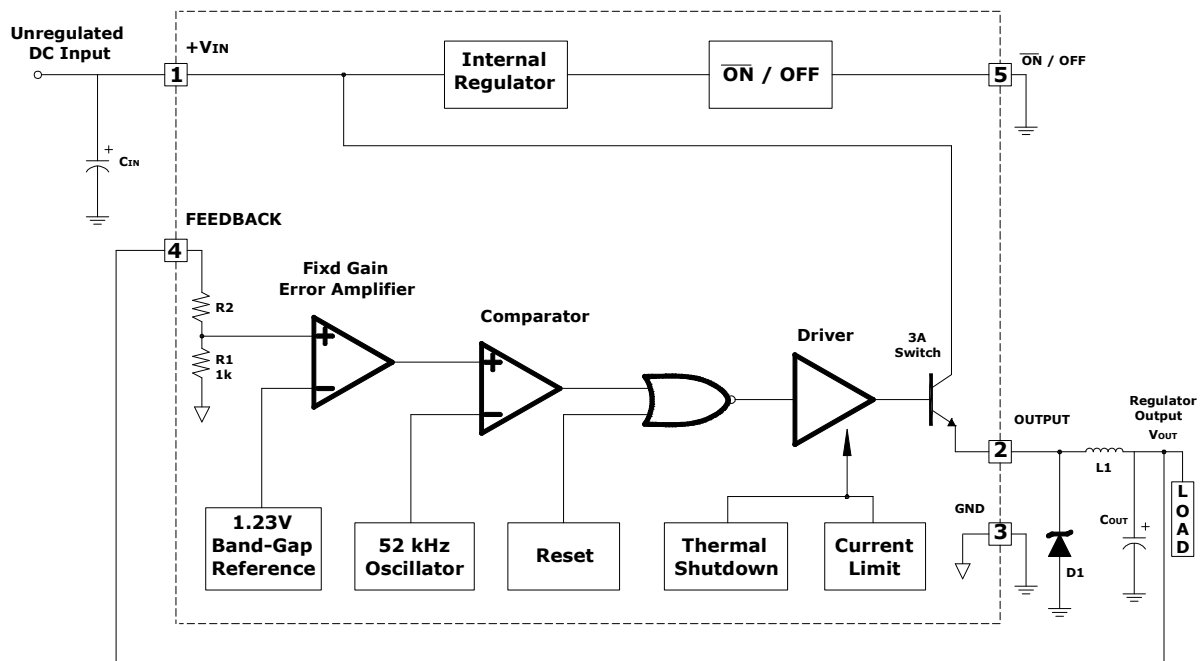

Packages & Pin Assignments

GS2576TF (TO-220)		GS2576MF (TO-263)		GS2576DF (TO-252)	
1	INPUT	1	INPUT	1	INPUT
2	OUTPOT	2	OUTPOT	2	OUTPOT
3	GND	3	GND	3	GND
4	Feedback	4	Feedback	4	Feedback
5	ON/OFF	5	ON/OFF	5	ON/OFF

Ordering Information

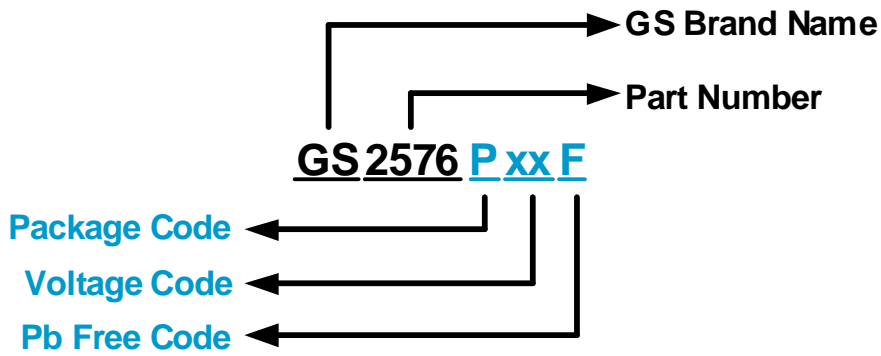

(TO-220)	(TO-263)	(TO-252)	Output Voltage
GS2576TF	GS2576MF	GS2576DF	ADJ
GS2576T33F	GS2576M33F	GS2576D33F	3.3v
GS2576T50F	GS2576M50F	GS2576D50F	5.0v

*For other voltages, please contact factory.

Marking Information

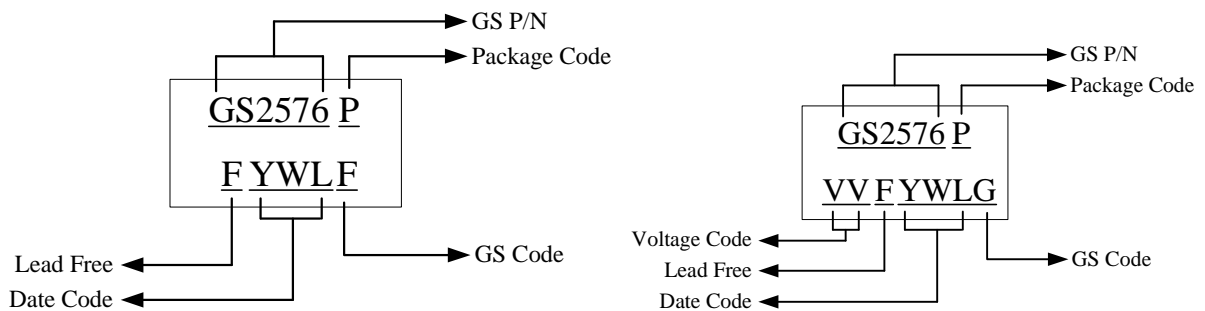

Absolute Maximum Ratings

Parameter	Symbol	Max	Units
Maximum Supply Voltage	V_{IN}	40	V
Thermal Resistance Junction to Ambient ₍₁₎	θ_{JA}	TO-220	62.5
		TO-263	62.5
		TO-252	104
Power Dissipation	P_D	TO-220	2
		TO-263	2
		TO-252	1.2
ON/OFF Pin Input Voltage	V_{SW}	$-0.3V \leq V \leq +V_{IN}$	V
Output Voltage to Ground (Steady State)	V_{OUT}	-1	V
Storage Temperature Range	T_{STG}	-65 to +150	°C
Operating Junction Temperature	T_A	-40°C to 125°C	°C
Lead Temperature (Soldering, 10 Seconds)	T_{LEAD}	260	°C
Minimum ESD Rating (C=100pF, R=1.5KΩ)	ESD	2	kV

Note:

Stresses above those listed under “Absolute Maximum Ratings” may cause permanent damage to the device. These are stress ratings only and functional operation of the device at these or any other conditions above those indicated in the operation sections of the specifications is not implied.

Exposure to Absolute Maximum Ratings conditions for extended periods may affect device reliability.

Electrical Characteristics

GS2576-3.3

Parameter	Symbol	Conditions	MIN	TYP	MAX	Unit
Output Voltage	V_{OUT}	$V_{IN}=12V, I_{LOAD}=0.5A, T_J=25^\circ C$	3.234	3.3	3.366	V
		$6V \leq V_{IN} \leq 40V, 0.5A \leq I_{LOAD} \leq 3A$				
		$T_J=25^\circ C$	3.168	3.3	3.432	
		$T_J=-40^\circ C$ to $125^\circ C$	3.135	3.3	3.465	
Efficiency	η	$V_{IN}=12V, I_{LOAD}=3A$		75		%

GS2576-5.0

Parameter	Symbol	Conditions	MIN	TYP	MAX	Unit
Output Voltage	V_{OUT}	$V_{IN}=12V, I_{LOAD}=0.5A, T_J=25^\circ C$	4.90	5.0	5.10	V
		$8V \leq V_{IN} \leq 40V, 0.5A \leq I_{LOAD} \leq 3A$				
		$T_J=25^\circ C$	4.80	5.0	5.2	
		$T_J=-40^\circ C$ to $125^\circ C$	4.75	5.0	5.25	
Efficiency	η	$V_{IN}=12V, I_{LOAD}=3A$		77		%

GS2576-ADJ

Parameter	Symbol	Conditions	MIN	TYP	MAX	Unit
Output Voltage	V_{OUT}	$V_{IN}=12V, I_{LOAD}=0.5A, V_{OUT}=5V, T_J=25^\circ C$	1.217	1.23	1.243	V
		$6V \leq V_{IN} \leq 40V, 0.5A \leq I_{LOAD} \leq 3A$				
		$T_J=25^\circ C$	1.193	1.23	1.267	
		$T_J=-40^\circ C$ to $125^\circ C$	1.180	1.23	1.280	
Efficiency	η	$V_{IN}=12V, I_{LOAD}=3A, V_{OUT}=5V$		77		%

Note 1:

External components such as the catch diode, inductor, input and output capacitors can affect switching regulator system performance. When the GS2576 is used as shown in the Figure 7 test circuit, system performance will be shown in system parameters section.

Electrical Characteristics (Continued)

(Test circuit of figure 1)

Unless otherwise specified, $V_{IN} = 12V$ for the 3.3V, 5V, and Adjustable version, $I_{LOAD} = 500mA$. For typical values $T_J = 25^\circ C$, for min/max values T_J is the operating junction temperature range that applied [Note 2], unless otherwise noted.)

Parameter	Symbol	Conditions	MIN	TYP	MAX	Unit
Device Parameters						
Feedback Bias Current	I_B	$V_{OUT} = 5V$ (Adjustable Version Only)				
		$T_J = 25^\circ C$	-	50	100	nA
		$T_J = -40^\circ C$ to $125^\circ C$	-	-	500	nA
Oscillator Frequency	F_{OSC}	$T_J = 25^\circ C$ (Note 3)	-	52	-	kHz
		$T_J = 0^\circ C$ to $125^\circ C$	47	-	58	kHz
		$T_J = -40^\circ C$ to $125^\circ C$	42	-	63	kHz
Saturation Voltage	V_{SAT}	$I_{OUT} = 3A$ (Note 4)				
		$T_J = 25^\circ C$	-	1.4	1.8	V
		$T_J = -40^\circ C$ to $125^\circ C$	-	-	2.0	V
Max Duty Cycle (ON)	DC	(Note 5)	93	98	-	%
Current Limit	I_{CL}	(Notes 3, 4)				
		$T_J = 25^\circ C$	4.2	5.8	6.9	A
		$T_J = -40^\circ C$ to $125^\circ C$	3.5	-	7.5	A
Output Leakage Current	I_L	$T_J = 25^\circ C$ (Notes 6, 7)				
		Output = 0V	-	0.8	2.0	mA
		Output = -1V	-	7.5	30	mA
Quiescent Current	I_Q	(Note 6) $T_J = 25^\circ C$	-	5	10	mA
Standby Quiescent Current	I_{STBY}	$\overline{ON/OFF}$ Pin=5V(OFF), $T_J = 25^\circ C$	-	50	200	μA
ON/OFF Control						
ON/OFF Pin Logic Input Level	V_{IH}	$V_{OUT} = 0V$, $T_J = 25^\circ C$	2.2	1.4	-	V
		$V_{OUT} = 0V$, $T_J = -40^\circ C$ to $125^\circ C$	2.4	-	-	V
ON/OFF Pin Logic Input Level	V_{IL}	$V_{OUT} = \text{Nominal Output Voltage}$				
		$T_J = 25^\circ C$	-	1.2	1.0	V
		$T_J = -40^\circ C$ to $125^\circ C$	-	-	0.8	V
ON/OFF Pin Input Current	I_{IH}	$\overline{ON/OFF}$ Pin=5V(OFF), $T_J = 25^\circ C$	-	12	30	μA
ON/OFF Pin Input Current	I_{IL}	$\overline{ON/OFF}$ Pin=0V(ON), $T_J = 25^\circ C$	-	0	10	μA

Note 2: Test junction temperature range for the GS2576: $T_{LOW} = -40^\circ C$ $T_{HIGH} = +125^\circ C$

Note 3: The oscillator frequency reduces to approximately 18kHz in the event of an output short or an overload which causes the regulated output voltage to drop approximately 40% from the nominal output voltage. The self-protection feature lowers the average dissipation of the IC by lowering the minimum duty cycle from 5% down to approximately 2%.

Note 4: Output (Pin 2) sourcing current. No diode, inductor or capacitor connected to output pin.

Note 5: Feedback (Pin 4) removed from output and connected to 0V.

Note 6: Feedback (Pin 4) removed from output and connected to +12V for the Adjustable, 3.3V and 5V versions, and +25V for the 12V version, to force the output transistor "OFF".

Note 7: $V_{IN} = 40V$.

Typical Applications

As in any switching regulator, the layout of the printed board (PCB) is very important. Rapidly switching currents associated with wiring inductance, stray capacitance and parasitic inductance of the printed circuit board traces can generate voltage transients, which can generate electromagnetic interferences (EMI) and affect the desired operation. As indicated in the Figure 1, to minimize inductance and ground loops, the length of the leads indicated by heavy lines should be kept as short as possible.

For best results, single-point grounding (as indicated) or ground plane construction should be used.

On the other hand, the PCB area connected to the Pin 2 (emitter of the internal switch) of the GS2576 should be kept to a minimum in order to minimize coupling to sensitive circuitry.

Another sensitive part of the circuit is the feedback. It is important to keep the sensitive feedback wiring short. To assure this, physically locate the programming resistors near to the regulator, when using the Adjustable version of the GS2576 regulator.

Fixed Output Voltage Versions (Figure 1a)

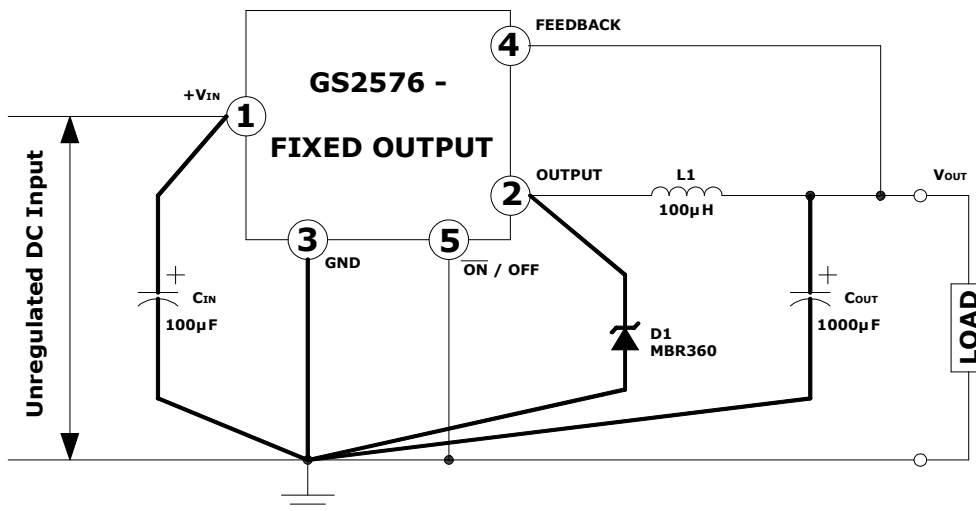

Adjustable Output Voltage Version (Figure 1b)

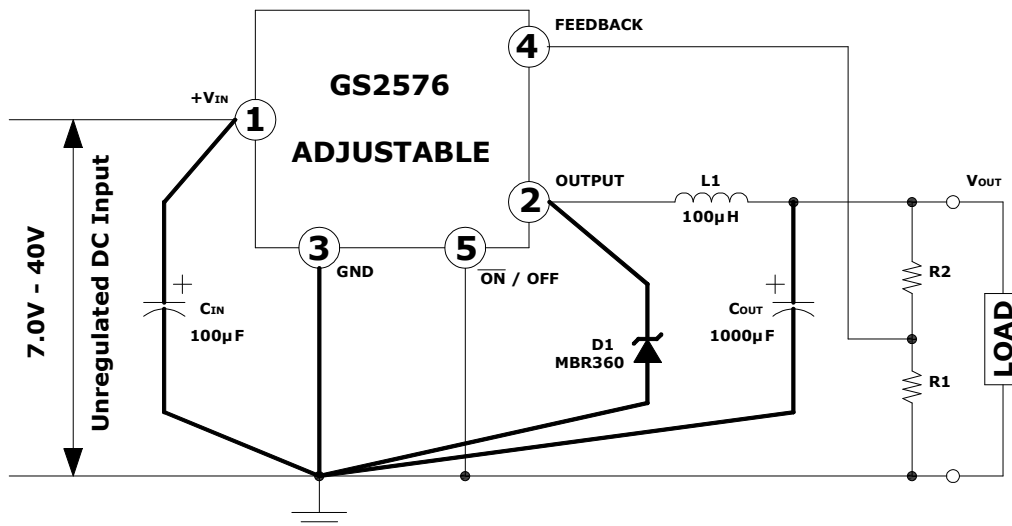

C_{IN} —100µF, 75V Aluminum Electrolytic

C_{OUT} —1000µF, 25V, Aluminum Electrolytic

D1—Schottky, MBR360

L_1 —100 µH

R1—2.0k, 0.1%

R2—6.12k, 0.1%

$V_{OUT} = V_{REF} (1 + R_2/R_1)$, $R_2 = R_1 (V_{OUT} / V_{REF} - 1)$, where $V_{REF} = 1.23V$, R1 between 1k and 5k

Typical Performance Characteristics

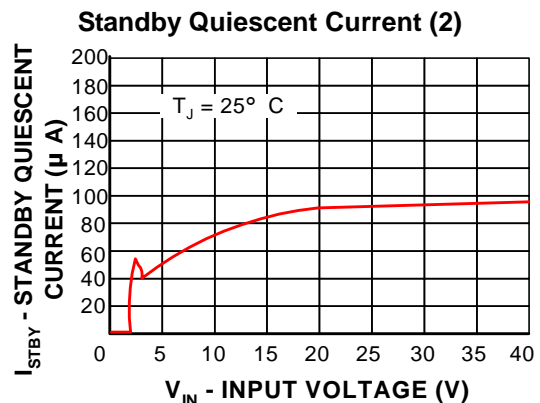
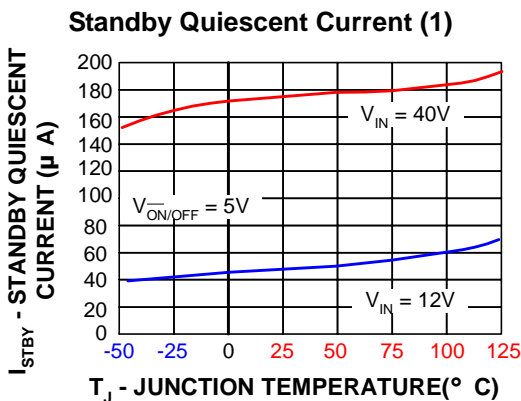
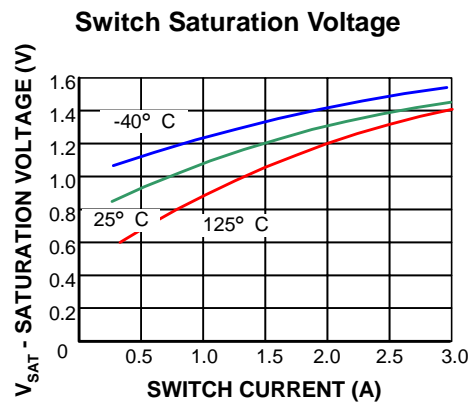
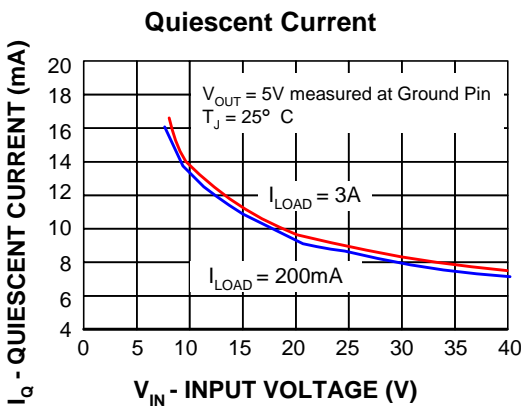
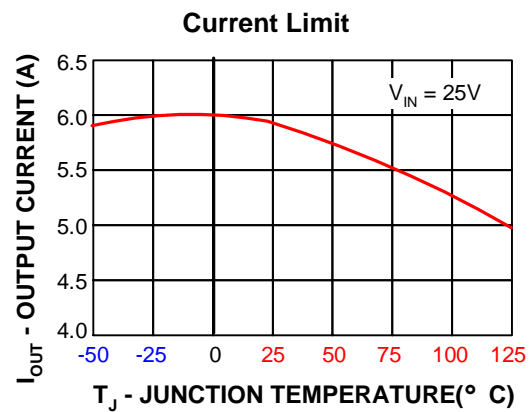
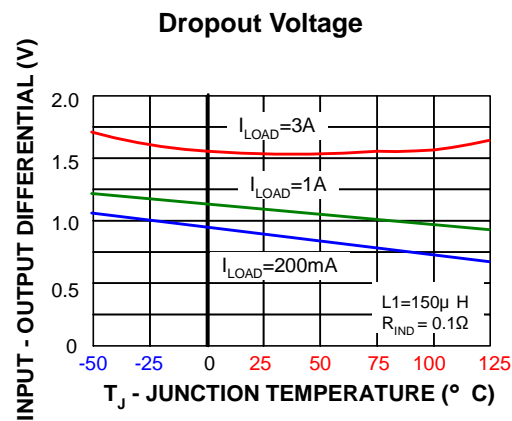
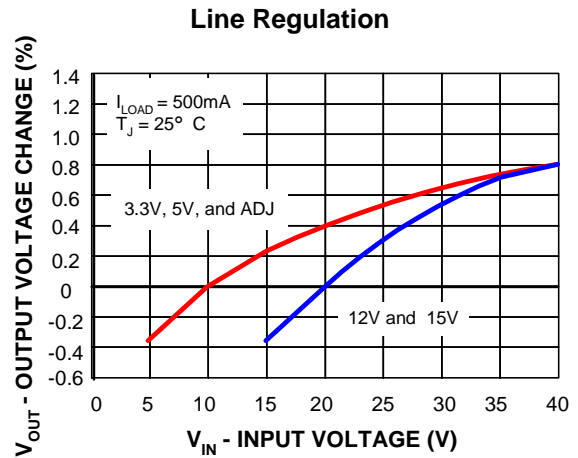
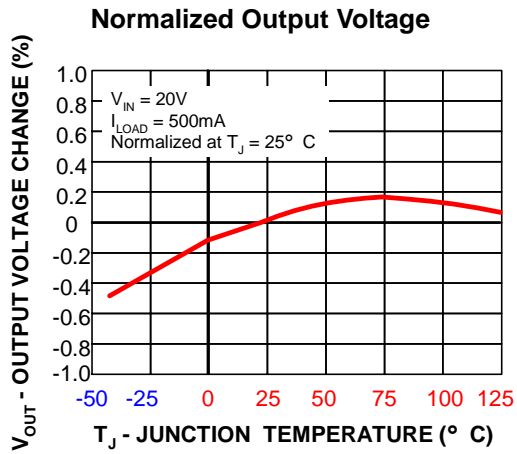

Typical Performance Characteristics (Continue)

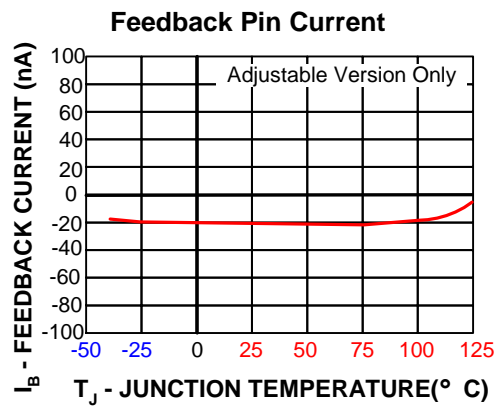
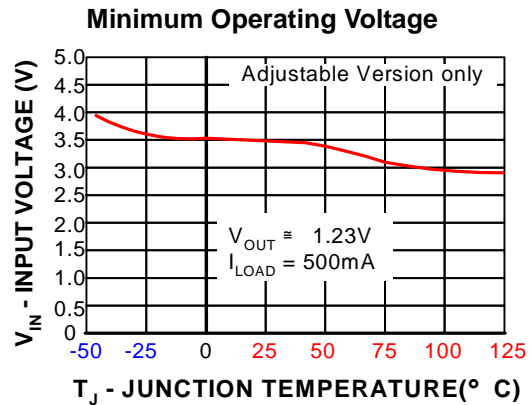
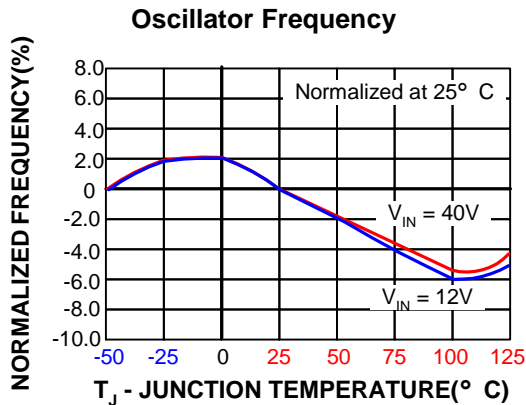

Design Procedure

PROCEDURE (Fixed Output Voltage Versions)	EXAMPLE (Fixed Output Voltage Versions)
<p>Given:</p> <p>V_{OUT} = Regulated Output Voltage (3.3V, 5V, 12V, or 15V)</p> <p>$V_{IN}(\text{Max})$ = Maximum Input Voltage</p> <p>$I_{LOAD}(\text{Max})$ = Maximum Load Current</p> <p>1. Inductor Selection (L1)</p> <p>A. Select the correct Inductor value selection guide from Figures 3, 4, 5 or Figure 6. (Output voltages of 3.3V, 5V, 12V or 15V respectively). For other output voltages, see the design procedure for the adjustable version.</p> <p>B. From the inductor value selection guide, identify the inductance region intersected by $V_{IN}(\text{Max})$ and $I_{LOAD}(\text{Max})$, and note the inductor code for that region.</p> <p>C. The inductor chosen must be rated for operation at the GS2576 switching frequency (52 kHz) and for a current rating of $1.15 \times I_{LOAD}$. For additional inductor information, see the inductor section in the Application Hints section of this data sheet.</p>	<p>Given:</p> <p>$V_{OUT} = 5V$</p> <p>$V_{IN}(\text{Max}) = 15V$</p> <p>$I_{LOAD}(\text{Max}) = 3A$</p> <p>1. Inductor Selection (L1)</p> <p>A. Use the selection guide shown in Figure 4.</p> <p>B. From the selection guide, the inductance area intersected by the 15V line and 3A line is L100.</p> <p>C. Inductor value required is 100 μH.</p>

Design Procedure (Continue)

<p>2. Output Capacitor Selection (C_{OUT})</p> <p>A. The value of the output capacitor together with the inductor defines the dominate pole-pair of the switching regulator loop. For stable operation and an acceptable output ripple voltage, (approximately 1% of the output voltage) a value between 100 μF and 470 μF is recommended.</p> <p>B. The capacitor's voltage rating should be at least 1.5 times greater than the output voltage. For a 5V regulator, a rating of at least 8V is appropriate, and a 10V or 15V rating is recommended. Higher voltage electrolytic capacitors generally have lower ESR numbers, and for this reason it may be necessary to select a capacitor rated for a higher voltage than would normally be needed.</p>	<p>2. Output Capacitor Selection (C_{OUT})</p> <p>A. C_{OUT} = 680 μF to 2000 μF standard aluminum electrolytic.</p> <p>B. Capacitor voltage rating = 20V.</p>
<p>3. Catch Diode Selection (D1)</p> <p>A. The catch-diode current rating must be at least 1.2 times greater than the maximum load current. Also, if the power supply design must withstand a continuous output short, the diode should have a current rating equal to the maximum current limit of the GS2576. The most stressful condition for this diode is an overload or shorted output condition.</p> <p>B. The reverse voltage rating of the diode should be at least 1.25 times the maximum input voltage.</p>	<p>3. Catch Diode Selection (D1)</p> <p>A. For this example, a 3A current rating is adequate.</p> <p>B. Use a 20V 1N5823 or SR302 Schottky diode.</p>
<p>4. Input Capacitor (C_{IN})</p> <p>An aluminum or tantalum electrolytic bypass capacitor located close to the regulator is needed for stable operation.</p>	<p>4. Input Capacitor (C_{IN})</p> <p>A 100 μF, 25V aluminum electrolytic capacitor located near the input and ground pins provides sufficient bypassing.</p>
<p>PROCEDURE (Adjustable Output Version)</p>	<p>EXAMPLE (Adjustable Output Version)</p>
<p>Given:</p> <p>V_{OUT} = Regulated Output Voltage V_{IN (Max)} = Maximum Input Voltage I_{LOAD (Max)} = Maximum Load Current F = Switching Frequency (Fixed at 52 kHz)</p>	<p>Given:</p> <p>V_{OUT} = 10V V_{IN (Max)} = 25V I_{LOAD (Max)} = 3A F = 52 kHz</p>
<p>1. Programming Output Voltage (Selecting R₁ and R₂, as shown in Figure 1)</p> <p>Use the following formula to select the appropriate resistor values.</p> $V_{OUT} = V_{REF} \left(1 + \frac{R_2}{R_1}\right) \quad \text{where } V_{REF} = 1.23V$ <p>R₁ can be between 1k and 5k. (For best temperature coefficient and stability with time, use 1% metal film resistors)</p> $R_2 = R_1 \left(\frac{V_{OUT}}{V_{REF}} - 1\right)$	<p>1. Programming Output Voltage (Selecting R₁ and R₂)</p> $V_{OUT} = 1.23 \left(1 + \frac{R_2}{R_1}\right) \quad \text{Select } R_1 = 1k$ $R_2 = R_1 \left(\frac{V_{OUT}}{V_{REF}} - 1\right) = 1k \left(\frac{10V}{1.23V} - 1\right)$ <p>R₂ = 1k (8.13 - 1) = 7.13k, closest 1% value is 7.15k</p>
<p>2. Inductor Selection (L1)</p> <p>A. Calculate the inductor Volt • microsecond constant, E • T (V • μs), from the following formula:</p> $E \cdot T = (V_{IN} - V_{OUT}) \frac{V_{OUT}}{V_{IN}} \cdot \frac{1000}{F(\text{in kHz})} \quad (V \cdot \mu s)$ <p>B. Use the E • T value from the previous formula and match it with the E • T number on the vertical axis of the Inductor Value Selection Guide</p>	<p>2. Inductor Selection (L1)</p> <p>A. Calculate E • T (V • μs)</p> $E \cdot T = (25 - 10) \cdot \frac{10}{25} \cdot \frac{1000}{52} = 115 \quad (V \cdot \mu s)$ <p>B. E • T = 115 V • μs C. I_{LOAD (Max)} = 3A D. Inductance Region = H150 E. Inductor Value = 150 μH</p>

Design Procedure (Continue)

<p>C. On the horizontal axis, select the maximum load current.</p> <p>D. Identify the inductance region intersected by the E • T value and the maximum load current value, and note the inductor code for that region.</p> <p>E. The inductor chosen must be rated for operation at the GS2576 switching frequency (52 kHz) and for a current rating of $1.15 \times I_{LOAD}$. For additional inductor information, see the inductor section in the application hints section of this data sheet.</p>	
<p>3. Output Capacitor Selection (C_{OUT})</p> <p>A. The value of the output capacitor together with the inductor defines the dominate pole-pair of the switching regulator loop. For stable operation, the capacitor must satisfy the following requirement:</p> $C_{OUT} \geq 13,300 \frac{V_{IN(MAX)}}{V_{OUT} \cdot L(\mu H)} (\mu F)$ <p>The above formula yields capacitor values between 10 μF and 2200 μF that will satisfy the loop requirements for stable operation. But to achieve an acceptable output ripple voltage, (approximately 1% of the output voltage) and transient response, the output capacitor may need to be several times larger than the above formula yields.</p> <p>B. The capacitor's voltage rating should be at last 1.5 times greater than the output voltage. For a 10V regulator, a rating of at least 15V or more is recommended. Higher voltage electrolytic capacitors generally have lower ESR numbers, and for this reason it may be necessary to select a capacitor rate for a higher voltage than would normally be needed.</p>	<p>3. Output Capacitor Selection (C_{OUT})</p> $C_{OUT} > 13,300 \frac{25}{10 \cdot 150} = 22.2(\mu F)$ <p>However, for acceptable output ripple voltage select $C_{OUT} \geq 680 \mu F$ $C_{OUT} = 680 \mu F$ electrolytic capacitor</p>
<p>4. Catch Diode Selection (D1)</p> <p>A. The catch-diode current rating must be at least 1.2 times greater than the maximum load current. Also, if the power supply design must withstand a continuous output short, the diode should have a current rating equal to the maximum current limit of the GS2576. The most stressful condition for this diode is an overload or shorted output.</p> <p>B. The reverse voltage rating of the diode should be at least 1.25 times the maximum input voltage.</p>	<p>4. Catch Diode Selection (D1)</p> <p>A. For this example, a 3.3A current rating is adequate.</p> <p>B. Use a 30V 31DQ03 Schottky diode.</p>
<p>5. Input Capacitor (C_{IN})</p> <p>An aluminum or tantalum electrolytic bypass capacitor located close to the regulator is needed for stable operation.</p>	<p>5. Input Capacitor (C_{IN})</p> <p>A 100μF aluminum electrolytic capacitor located near the input and ground pins provides sufficient bypassing.</p>

Application Information (Continue)

INPUT CAPACITOR (C_{IN})

To maintain stability, the regulator input pin must be bypassed with at least a 100 μF electrolytic capacitor. The capacitor's leads must be kept short, and located near the regulator.

If the operating temperature range includes temperatures below -25°C, the input capacitor value may need to be larger. With most electrolytic capacitors, the capacitance value decreases and the ESR increases with lower temperatures and age. Paralleling a ceramic or solid tantalum capacitor will increase the regulator stability at cold temperatures. For maximum capacitor operating lifetime, the capacitor's RMS ripple current rating should be greater than

$$1.2 \times \left(\frac{t_{ON}}{T} \right) \times I_{LOAD}$$

where $\frac{t_{ON}}{T} = \frac{V_{OUT}}{V_{IN}}$ for a buck regulator

and $\frac{t_{ON}}{T} = \frac{|V_{OUT}|}{|V_{OUT}| + V_{IN}}$ for a buck-boost regulator.

INDUCTOR SELECTION

All switching regulators have two basic modes of operation: continuous and discontinuous. The difference between the two types relates to the inductor current, whether it is flowing continuously, or if it drops to zero for a period of time in the normal switching cycle. Each mode has distinctively different operating characteristics, which can affect the regulator performance and requirements.

The GS2576 can be used for both continuous and discontinuous modes of operation.

The inductor value were designed for buck regulator designs of the continuous inductor current type. When using inductor values shown in the inductor selection guide, the peak-to-peak inductor ripple current will be approximately 20% to 30% of the maximum DC current. With relatively heavy load currents, the circuit operates in the continuous mode (inductor current always flowing), but under light load conditions, the circuit will be forced to the discontinuous mode (inductor current falls to zero for a period of time). This discontinuous mode of operation is perfectly acceptable. For light loads (less than approximately 300 mA) it may be desirable to operate the regulator in the discontinuous mode, primarily because of the lower inductor values required for the discontinuous mode.

The selection guide chooses inductor values suitable for continuous mode operation, but if the inductor value chosen is prohibitively high, the designer should investigate the possibility of discontinuous operation.

Inductors are available in different styles such as pot core, toroid, E-frame, bobbin core, etc., as well as different core materials, such as ferrites and powdered iron. The least expensive, the bobbin core type, consists of wire wrapped on a ferrite rod core. This type of construction makes for an inexpensive inductor, but since the magnetic flux is not completely contained within the core, it generates more electromagnetic interference (EMI). This EMI can cause problems in sensitive circuits, or can give incorrect scope readings because of induced voltages in the scope probe.

The inductors listed in the selection chart include ferrite pot core construction for AIE, powdered iron toroid for Pulse Engineering, and ferrite bobbin core for Renco.

An inductor should not be operated beyond its maximum rated current because it may saturate. When an inductor begins to saturate, the inductance decreases rapidly and the inductor begins to look mainly resistive (the DC resistance of the winding). This will cause the switch current to rise very rapidly. Different inductor types have different saturation characteristics, and this should be kept in mind when selecting an inductor.

The inductor manufacturer's data sheets include current and energy limits to avoid inductor saturation.

Application Information (Continue)

Inductor Ripple Current

When the switcher is operating in the continuous mode, the inductor current waveform ranges from a triangular to a sawtooth type of waveform (depending on the input voltage). For a given input voltage and output voltage, the peak-to-peak amplitude of this inductor current waveform remains constant. As the load current rises or falls, the entire sawtooth current waveform also rises or falls. The average DC value of this waveform is equal to the DC load current (in the buck regulator configuration).

If the load current drops to a low enough level, the bottom of the sawtooth current waveform will reach zero, and the switcher will change to a discontinuous mode of operation. This is a perfectly acceptable mode of operation. Any buck switching regulator (no matter how large the inductor value is) will be forced to run discontinuous if the load current is light enough.

Output Capacitor

An output capacitor is required to filter the output voltage and is needed for loop stability. The capacitor should be located near the GS2576 using short pc board traces. Standard aluminum electrolytics are usually adequate, but low ESR types are recommended for low output ripple voltage and good stability. The ESR of a capacitor depends on many factors, some which are: the value, the voltage rating, physical size and the type of construction. In general, low value or low voltage (less than 12V) electrolytic capacitors usually have higher ESR numbers.

The amount of output ripple voltage is primarily a function of the ESR (Equivalent Series Resistance) of the output capacitor and the amplitude of the inductor ripple current (ΔI_{IND}). See the section on inductor ripple current in Application Hints.

The lower capacitor values (220 μ F–1000 μ F) will allow typically 50 mV to 150 mV of output ripple voltage, while larger-value capacitors will reduce the ripple to approximately 20 mV to 50 mV.

Output Ripple Voltage = (ΔI_{IND}) (ESR of C_{OUT})

To further reduce the output ripple voltage, several standard electrolytic capacitors may be paralleled, or a higher-grade capacitor may be used. Such capacitors are often called “high-frequency,” “low-inductance,” or “low-ESR.” These will reduce the output ripple to 10 mV or 20 mV. However, when operating in the continuous mode, reducing the ESR below 0.03W can cause instability in the regulator. Tantalum capacitors can have a very low ESR, and should be carefully evaluated if it is the only output capacitor. Because of their good low temperature characteristics, a tantalum can be used in parallel with aluminum electrolytic, with the tantalum making up 10% or 20% of the total capacitance. The capacitor's ripple current rating at 52 kHz should be at least 50% higher than the peak-to-peak inductor ripple current.

Catch Diode

Buck regulators require a diode to provide a return path for the inductor current when the switch is off. This diode should be located close to the GS2576 using short leads and short printed circuit traces.

Because of their fast switching speed and low forward voltage drop, Schottky diodes provide the best efficiency, especially in low output voltage switching regulators (less than 5V). Fast-Recovery, High-Efficiency, or Ultra-Fast Recovery diodes are also suitable, but some types with an abrupt turn-off characteristic may cause instability and EMI problems. A fast-recovery diode with soft recovery characteristics is a better choice. Standard 60 Hz diodes (e.g., 1N4001 or 1N5400, etc.) are also **not suitable**.

Output Voltage Ripple and Transients

The output voltage of a switching power supply will contain a sawtooth ripple voltage at the switcher frequency, typically about 1% of the output voltage, and may also contain short voltage spikes at the peaks of the sawtooth waveform.

The output ripple voltage is due mainly to the inductor sawtooth ripple current multiplied by the ESR of the output capacitor. (See the inductor selection in the application hints.) The voltage spikes are present because of the fast switching action of the output switch, and the parasitic inductance of the output filter capacitor. To minimize these voltage spikes, special low inductance capacitors can be used, and their lead lengths must be kept short. Wiring inductance, stray capacitance, as well as the scope probe used to evaluate these transients, all contribute to the amplitude of these spikes.

An additional small LC filter (20 μ H & 100 μ F) can be added to the output (as shown in Figure 7) to further reduce the amount of output ripple and transients. A 10 x reduction in output ripple voltage and transients is possible with this filter.

Application Information (Continue)

Feedback Connection

The GS2576 (fixed voltage versions) feedback pin must be wired to the output voltage point of the switching power supply. When using the adjustable version, physically locate both output voltage programming resistors near the GS2576 to avoid picking up unwanted noise. Avoid using resistors greater than 100 k Ω because of the increased chance of noise pickup.

On /Off Input

For normal operation, the ON/OFF pin should be grounded or driven with a low-level TTL voltage (typically below 1.6V). To put the regulator into standby mode, drive this pin with a high-level TTL or CMOS signal. The ON /OFF pin can be safely pulled up to +VIN without a resistor in series with it. The ON/OFF pin should not be left open.

Grounding

To maintain output voltage stability, the power ground connections must be low-impedance (see Figure 1). For the 5-lead TO-220 and TO-263 style package, both the tab and pin 3 are ground and either connection may be used, as they are both part of the same copper lead frame.

Heat Sink/Thermal Considerations

In many cases, only a small heat sink is required to keep the GS2576 junction temperature within the allowed operating range. For each application, to determine whether or not a heat sink will be required, the following must be identified:

1. Maximum ambient temperature (in the application).
2. Maximum regulator power dissipation (in application).
3. Maximum allowed junction temperature (125°C for the GS2576). For a safe, conservative design, an approximately 15°C cooler than the maximum temperatures should be selected.

4. GS2576 package thermal resistances θ_{JA} and θ_{JC} .

Total power dissipated by the GS2576 can be estimated as follows:

$$P_D = (V_{IN})(I_Q) + (V_O/V_{IN})(I_{LOAD})(V_{SAT})$$

where I_Q (quiescent current) and V_{SAT} can be found in the Characteristic Curves shown previously, V_{IN} is the applied minimum input voltage, V_O is the regulated output voltage, and I_{LOAD} is the load current. The dynamic losses during turn-on and turn-off are negligible if an Schottky type catch diode is used.

When no heat sink is used, the junction temperature rise can be determined by the following:

$$\Delta T_J = (P_D) (\theta_{JA})$$

To arrive at the actual operating junction temperature, add the junction temperature rise to the maximum ambient temperature.

$$T_J = \Delta T_J + T_A$$

If the actual operating junction temperature is greater than the selected safe operating junction temperature determined in step 3, then a heat sink is required.

When using a heat sink, the junction temperature rise can be determined by the following:

$$\Delta T_J = (P_D) (\theta_{JC} + \theta_{interface} + \theta_{Heat\ sink})$$

The operating junction temperature will be:

$$T_J = T_A + \Delta T_J$$

As above, if the actual operating junction temperature is greater than the selected safe operating junction temperature, then a larger heat sink is required (one that has a lower thermal resistance).

Additional Applications

Inverting Regulator

Figure 2 shows a GS2576-12 in a buck-boost configuration to generate a negative 12V output from a positive input voltage. This circuit bootstraps the regulator's ground pin to the negative output voltage, then by grounding the feedback pin; the regulator senses the inverted output voltage and regulates it to -12V.

For an input voltage of 12V or more, the maximum available output current in this configuration is approximately 700 mA. At lighter loads, the minimum input voltage required drops to approximately 4.7V.

The switch currents in this buck-boost configuration are higher than in the standard buck-mode design, thus lowering the available output current. Also, the start-up input current of the buck-boost converter is higher than the standard buck-mode regulator, and this may overload an input power source with a current limit less than 5A. Using a delayed turn-on or an undervoltage lockout circuit (described in the next section) would allow the input voltage to rise to a high enough level before the switcher would be allowed to turn on.

Because of the structural differences between the buck and the buck-boost regulator topologies, the buck regulator design procedure section can not be used to select the inductor or the output capacitor. The recommended range of inductor values for the buck-boost design is between 68 μ H and 220 μ H, and the output capacitor values must be larger than what is normally required for buck designs. Low input voltages or high output currents require a large value output capacitor (in the thousands of micro Farads).

The peak inductor current, which is the same as the peak switch current, can be calculated from the following formula:

$$I_P \approx \frac{I_{LOAD} (V_{IN} + |V_O|)}{V_{IN}} + \frac{V_{IN} |V_O|}{V_{IN} + |V_O|} \times \frac{1}{2L_1 f_{osc}}$$

Where $f_{osc} = 52$ kHz. Under normal continuous inductor current operating conditions, the minimum V_{IN} represents the worst case. Select an inductor that is rated for the peak current anticipated.

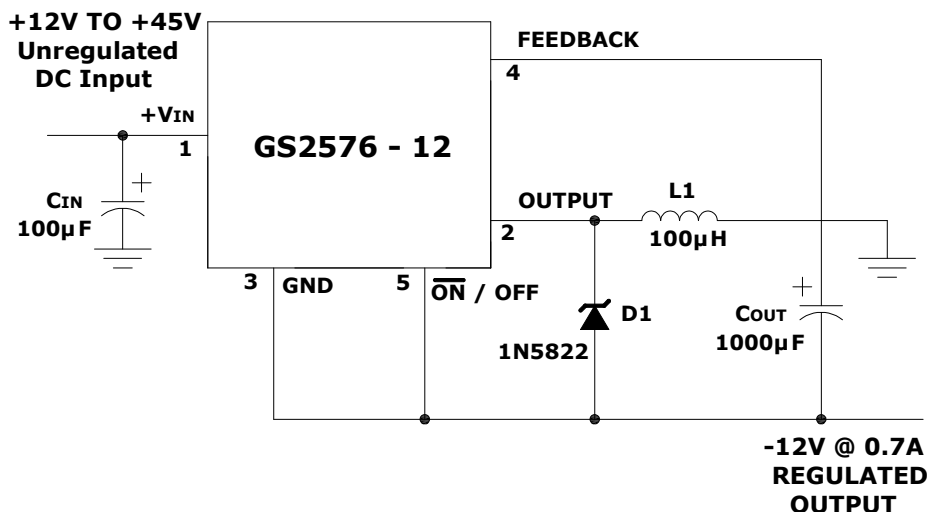

FIGURE 2. Inverting Buck-Boost Develops - 12V

Also, the maximum voltage appearing across the regulator is the absolute sum of the input and output voltage. For a -12V output, the maximum input voltage for the GS2576 is +28V.

Negative Boost Regulator

Another variation on the buck-boost topology is the negative boost configuration. The circuit in Figure 3 accepts an input voltage ranging from -5V to -12V and provides a regulated -12V output. Input voltages greater than -12V will cause the output to rise above -12V, but will not damage the regulator.

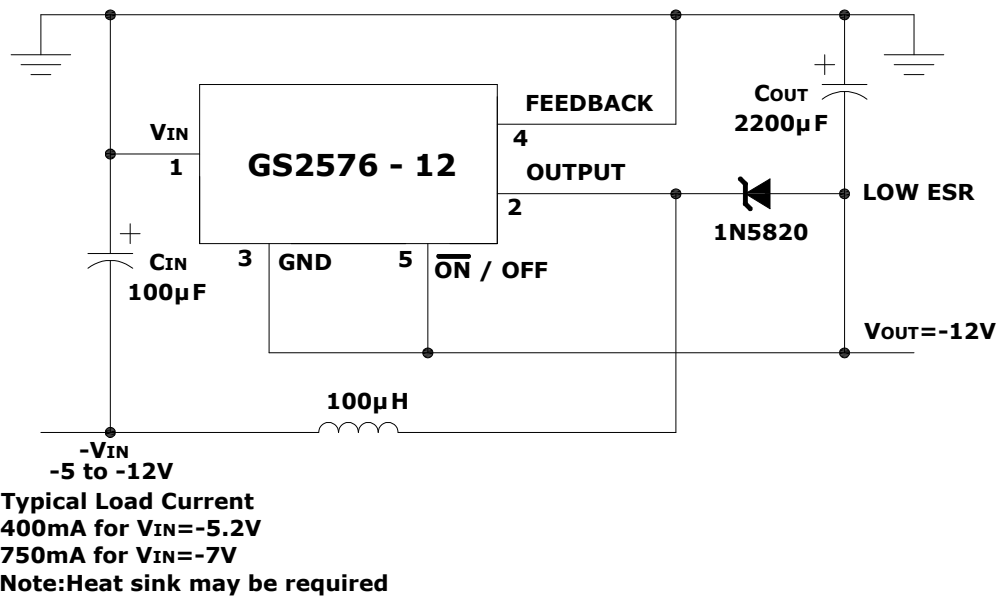

FIGURE 3. Negative Boost

Because of the boosting function of this type of regulator, the switch current is relatively high, especially at low input voltages. Output load current limitations are a result of the maximum current rating of the switch. Also, boost regulators can not provide current limiting load protection in the event of a shorted load, so some other means (such as a fuse) may be necessary.

Undervoltage Lockout

In some applications it is desirable to keep the regulator off until the input voltage reaches a certain threshold. An undervoltage lockout circuit that accomplishes this task is shown in Figure 4, while Figure 5 shows the same circuit applied to a buck-boost configuration. These circuits keep the regulator off until the input voltage reaches a predetermined level.

$$V_{TH} \approx V_{Z1} + 2V_{BE}(Q1)$$

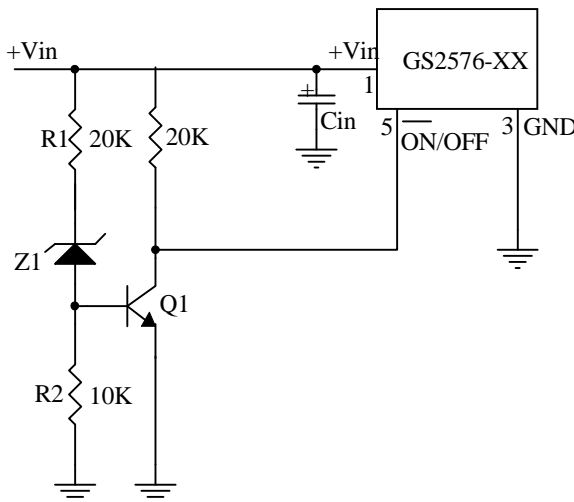

Note:Complete circuit not shown

FIGURE 4. Undervoltage Lockout for Buck Circuit

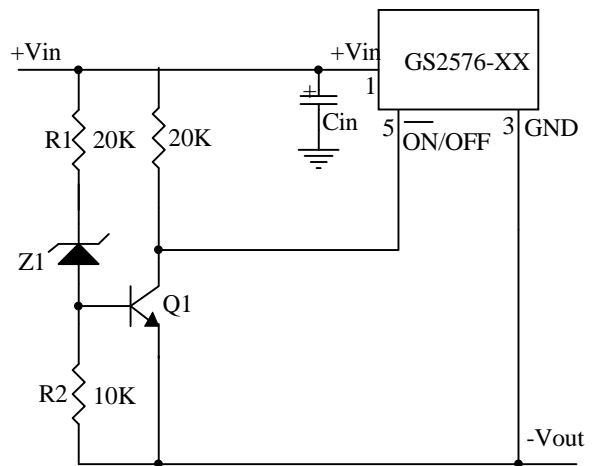

Note:Complete circuit not shown(see Figure 10)

FIGURE 5. Undervoltage Lockout for Buck-Boost Circuit

Delayed Startup

The ON /OFF pin can be used to provide a delayed startup feature as shown in Figure 6. With an input voltage of 20V and for the part values shown, the circuit provides approximately 10 ms of delay time before the circuit begins switching. Increasing the RC time constant can provide longer delay times. But excessively large RC time constants can cause problems with input voltages that are high in 60 Hz or 120 Hz ripple, by coupling the ripple into the ON /OFF pin.

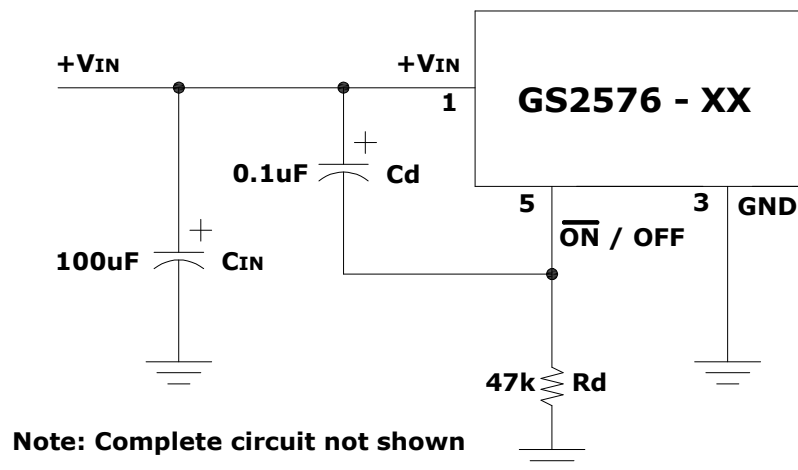

FIGURE 6. Delayed Startup

Adjustable Output, Low-Ripple Power Supply

A 3A power supply that features an adjustable output voltage is shown in Figure 7. An additional L-C filter that reduces the output ripple by a factor of 10 or more is included in this circuit.

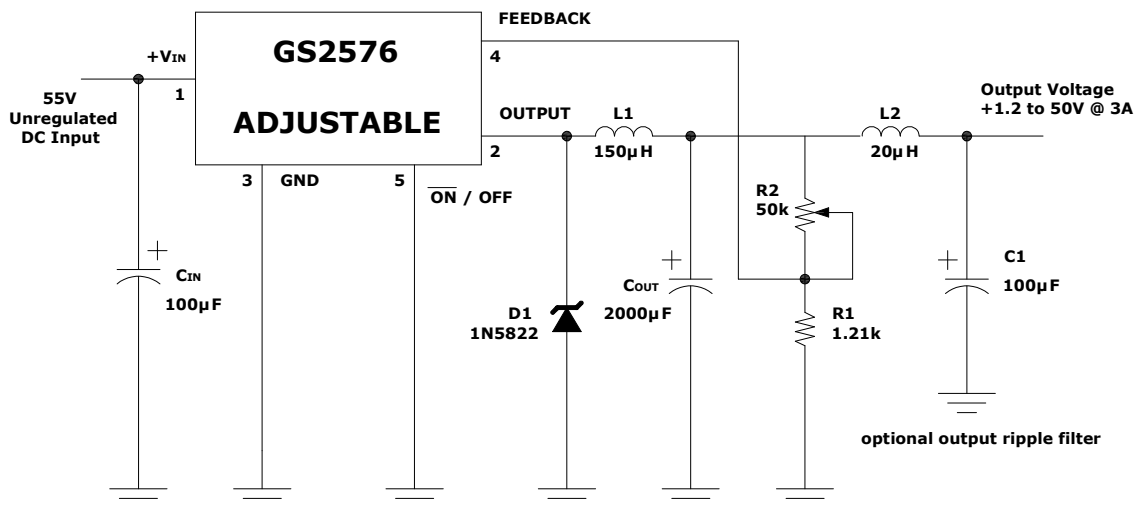

FIGURE 7. 1.2V to 55V Adjustable 3A Power Supply with Low Output Ripple

Definition of Terms

Buck Regulator

A switching regulator topology in which a higher voltage is converted to a lower voltage. Also known as a step-down switching regulator.

Buck-Boost Regulator

A switching regulator topology in which a positive voltage is converted to a negative voltage without a transformer.

Duty Cycle (D)

Ratio of the output switch's on-time to the oscillator period.

$$\text{for buck regulator } D = \frac{t_{\text{ON}}}{T} = \frac{V_{\text{OUT}}}{V_{\text{IN}}}$$

$$\text{for buck-boost regulator } D = \frac{t_{\text{ON}}}{T} = \frac{|V_{\text{O}}|}{|V_{\text{O}}| + V_{\text{IN}}}$$

Catch Diode or Current Steering Diode

The diode, which provides a return path for the load current when the GS2576 switch is OFF.

Efficiency (η)

The proportion of input power actually delivered to the load.

$$\eta = \frac{P_{\text{OUT}}}{P_{\text{IN}}} = \frac{P_{\text{OUT}}}{P_{\text{OUT}} + P_{\text{LOSS}}}$$

Capacitor Equivalent Series Resistance (ESR)

The purely resistive component of a real capacitor's impedance (see Figure 8). It causes power loss resulting in capacitor heating, which directly affects the capacitor's operating lifetime. When used as a switching regulator output filter, higher ESR values result in higher output ripple voltages.

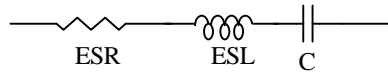

FIGURE 8. Simple Model of a Real Capacitor

Most standard aluminum electrolytic capacitors in the 100 μF –1000 μF range have 0.5 Ω to 0.1 Ω ESR. Higher-grade capacitors (“low-ESR”, “high-frequency”, or “low-inductance”) in the 100 μF –1000 μF range generally have ESR of less than 0.15 Ω .

Equivalent Series Inductance (ESL)

The pure inductance component of a capacitor (see Figure 8). The amount of inductance is determined to a large extent on the capacitor's construction. In a buck regulator, this unwanted inductance causes voltage spikes to appear on the output.

Output Ripple Voltage

The AC component of the switching regulator's output voltage. It is usually dominated by the output capacitor's ESR multiplied by the inductor's ripple current (DIIND). The peak-to-peak value of this sawtooth ripple current can be determined by reading the Inductor Ripple Current section of the Application hints.

Capacitor Ripple Current

RMS value of the maximum allowable alternating current at which a capacitor can be operated continuously at a specified temperature.

Standby Quiescent Current (I_{STBY})

Supply current required by the GS2576 when in the standby mode (ON /OFF pin is driven to TTL-high voltage, thus turning the output switch OFF).

Definition of Terms (Continue)**Inductor Ripple Current (ΔI_{IND})**

The peak-to-peak value of the inductor current waveform, typically a sawtooth waveform when the regulator is operating in the continuous mode (vs. discontinuous mode).

Continuous/Discontinuous Mode Operation

Relates to the inductor current. In the continuous mode, the inductor current is always flowing and never drops to zero, vs. the discontinuous mode, where the inductor current drops to zero for a period of time in the normal switching cycle.

Inductor Saturation

The condition, which exists when an inductor cannot hold any more magnetic flux. When an inductor saturates, the inductor appears less inductive and the resistive component dominates. Inductor current is then limited only by the DC resistance of the wire and the available source current.

Operating Volt Microsecond Constant ($E \cdot Top$)

The product (in Volt $\cdot\mu$ s) of the voltage applied to the inductor and the time the voltage is applied. This $E \cdot Top$ constant is a measure of the energy handling capability of an inductor and is dependent upon the type of core, the core area, the number of turns, and the duty cycle.

Package Dimension

TO-220-5L PLASTIC PACKAGE

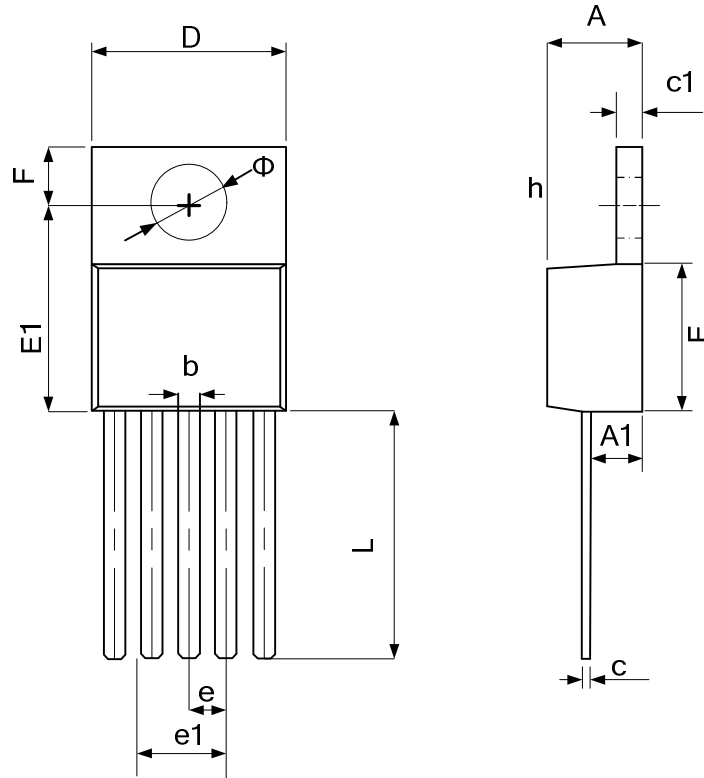

Dimensions				
SYMBOL	Millimeters		Inches	
	MIN	MAX	MIN	MAX
A	4.47	4.67	.176	.184
A1	2.52	2.82	.099	.111
b	0.71	0.91	.028	.036
c	0.31	0.53	.012	.021
c1	1.17	1.37	.046	.054
D	9.85	10.15	.388	.400
E	8.20	8.60	.323	.339
E1	11.76	12.16	.463	.479
e	1.70 (TYP)		0.067(TYP)	
e1	6.70	6.90	.264	.272
F	2.59	2.89	.102	.114
L	13.50	13.90	.531	.547
Φ	3.79	3.89	.149	.153

TO-263-5L PLASTIC PACKAGE

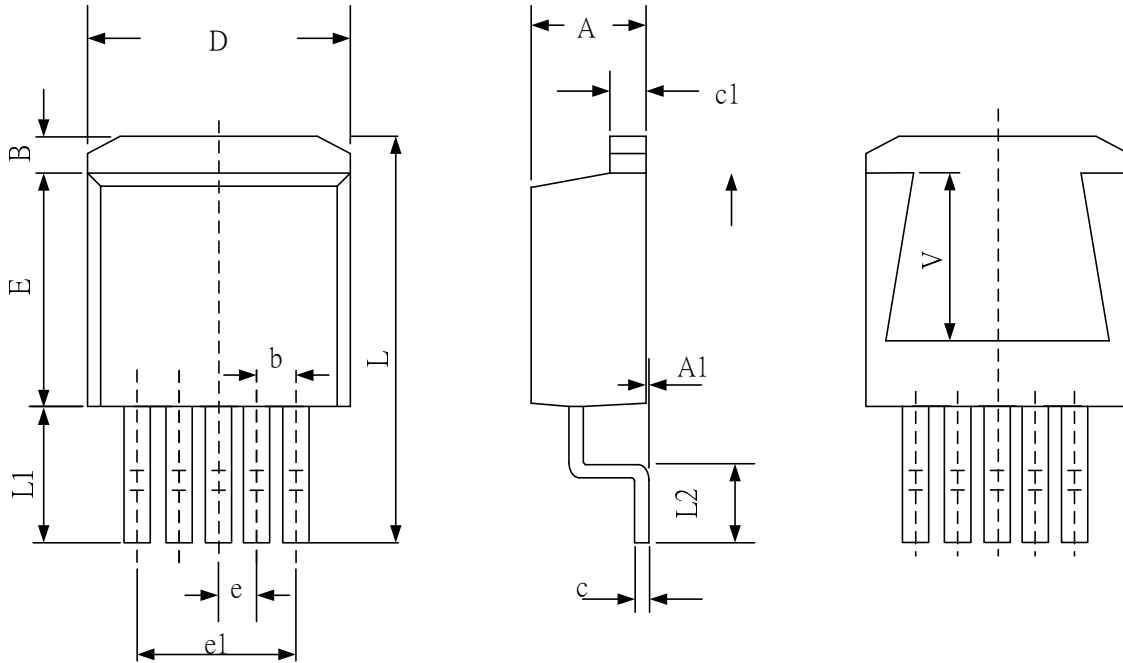

Symbol	Dimensions In Millimeters		Dimensions In Inches	
	Min	Max	Min	Max
A	4.470	4.670	0.176	0.184
A1	0.000	0.150	0.000	0.006
B	1.560	1.760	0.061	0.069
b	0.710	0.910	0.028	0.036
c	0.310	0.530	0.012	0.021
c1	1.170	1.370	0.046	0.054
D	9.880	10.180	0.389	0.401
E	8.200	8.600	0.323	0.339
e	1.700TYP		0.067TYP	
e1	6.700	6.900	0.264	0.272
L	15.140	15.540	0.596	0.612
L1	5.080	5.480	0.200	0.216
L2	2.340	2.740	0.092	0.108
V	5.600 REF		0.220 REF	

TO-252-5L PLASTIC PACKAGE

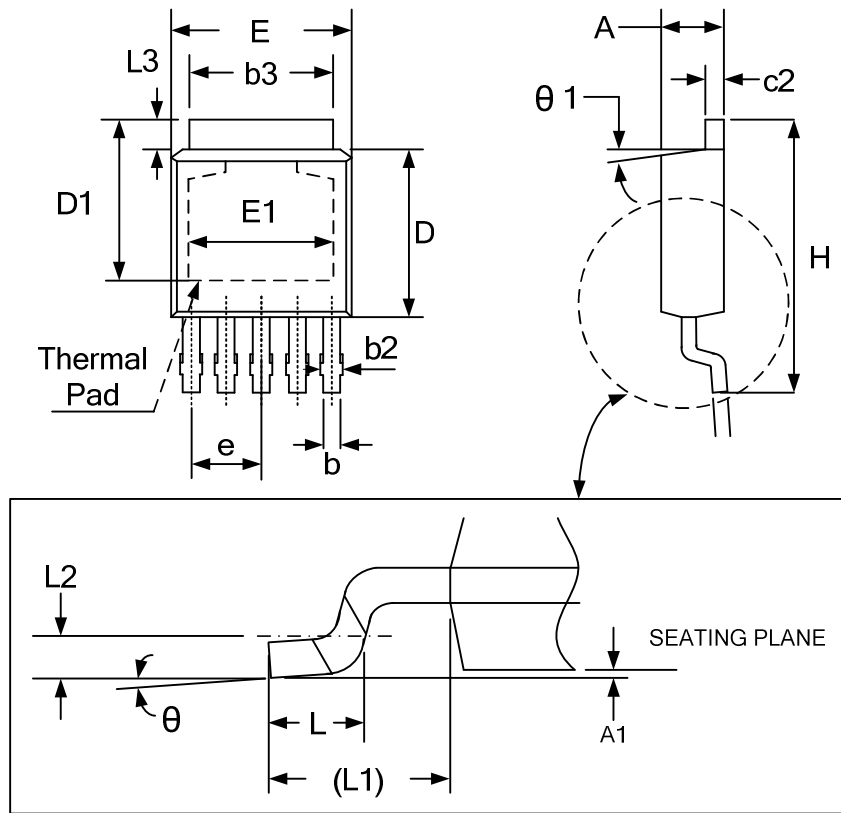

Symbol	Dimensions In Millimeters		Dimensions In Inches	
	Min	Max	Min	Max
A	2.210	2.387	.087	.094
A1	0.010	0.127	.0004	.005
b	0.584	0.660	.023	.026
b1	0.559	0.635	.022	.025
b2	0.635	0.787	.025	.031
b3	5.232	5.436	.206	.214
C	0.509	0.559	.020	.022
C1	0.457	0.533	.018	.021
C2	0.483	0.584	.019	.023
D	6.000	6.200	.236	.244
D1	5.415	5.515	.213	.217
E	6.400	6.604	.252	.260
E1	4.902	5.004	.193	.197
e	1.27 BSC		.050 BSC	
H	9.601	10.210	.378	.402
L	1.391	1.651	.055	.065
L1	2.743 REF		.108 REF	
L2	0.508 REF		.020 REF	
L3	1.100 REF		.043 REF	
θ	0°	8°	0°	8°
$\theta 1$	7° REF		7° REF	

NOTICE

Information furnished is believed to be accurate and reliable. However Globaltech Semiconductor assumes no responsibility for the consequences of use of such information nor for any infringement of patents or other rights of third parties, which may result from its use. No license is granted by implication or otherwise under any patent or patent rights of Globaltech Semiconductor. Specifications mentioned in this publication are subject to change without notice. This publication supersedes and replaces all information without express written approval of Globaltech Semiconductor.

(Revise Date:2007/11/13 Version_1.0)
