FEATURES

- **CIC suitable package size**
- **8:1 compression ratio**
- **38 dB maximum system gain, adjustable over a 38 dB range**
- **output compression threshold, adjustable over 16 dB range**
- **designed to drive a class D integrated receiver**
- **averaging detector**

STANDARD PACKAGING

Hybrid typical dimensions:

 0.162 in x 0.094 in x 0.070 in
 (4.11 mm x 2.39 mm x 1.78 mm)

DESCRIPTION

The GS3026 CIC hybrid features AGC-O capability for low distortion output limiting and offers a package size suitable for CIC instruments. The circuit consists of a newly designed AGC preamplifier and output stage, capable of driving the class D integrated receiver. The compression control circuit varies the current controlled resistance, connected between the input and output of the AGC preamplifier. The compression circuit operates with an 8:1 compression ratio and uses an averaging detector with a time constant of 270 ms, selected to provide optimal sound quality over the full range of sound and listening environments. The actual attack and release times are typically 40 ms and 150 ms respectively when the circuit is fully in the compression region of operation (measured times will vary depending on gain and threshold settings).

The system gain and compression control can be adjusted by the choice of two independent resistors. Maximum system gain is 38 dB and it can be adjusted within a 38 dB range. The output compression threshold can be adjusted within a 16 dB range.

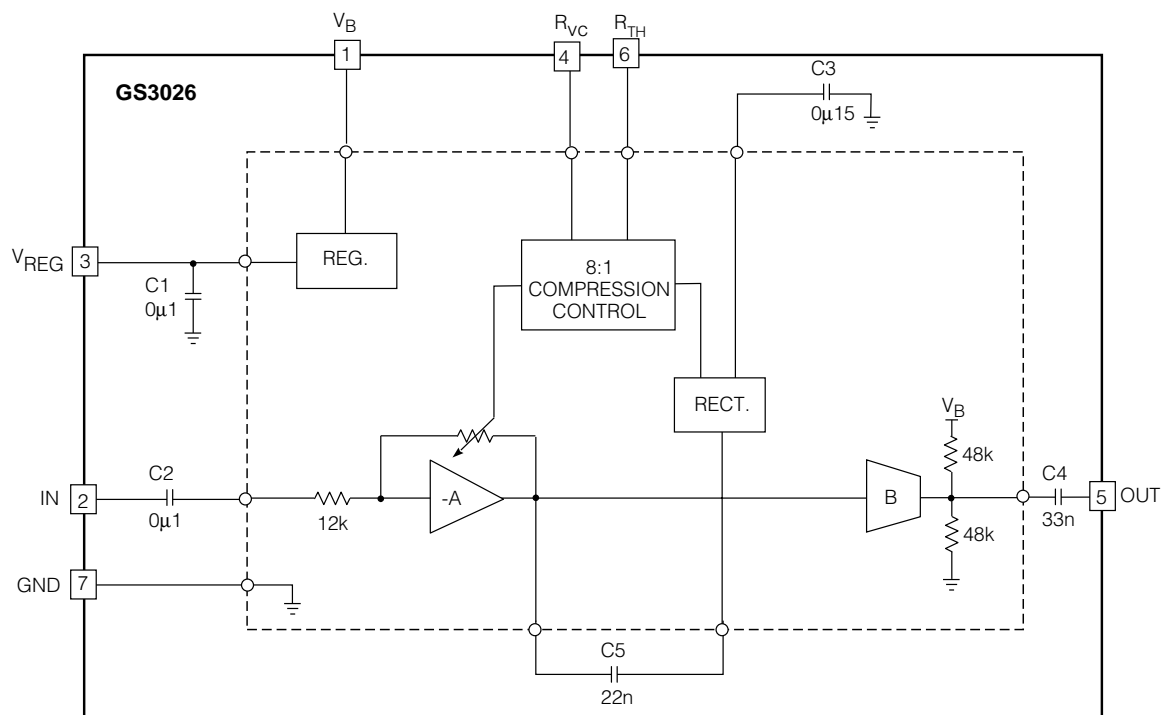

All resistors in ohms, all capacitors in farads unless otherwise stated.

BLOCK DIAGRAM

ABSOLUTE MAXIMUM RATINGS

PARAMETER	VALUE / UNITS
Supply Voltage	3 VDC
Power Dissipation	25 mW
Operating Temperature Range	-10° C to 40° C
Storage Temperature Range	-20° C to 70° C

CAUTION
CLASS 1 ESD SENSITIVITY

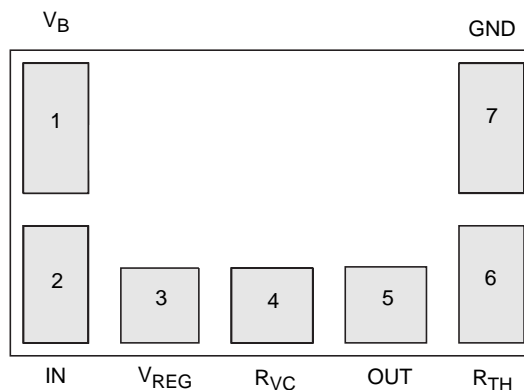
**PAD CONNECTION****ELECTRICAL CHARACTERISTICS**

Conditions: Frequency = 1 kHz, Temperature = 25°C, Supply Voltage $V_B = 1.3$ V

PARAMETER	SYMBOL	CONDITIONS	MIN	TYP	MAX	UNITS
Hybrid Current	I_{AMP}		-	165	240	μ A
Minimum Voltage	V_B		-	1.1	-	V
Total Harmonic Distortion	THD	$V_{IN} = -60$ dBV	-	0.5	1	%
Input Referred Noise	IRN	A weighted	-	2	2.5	μ VRMS
Total System Gain	A_V	$V_{IN} = -70$ dBV	35	38	41	dB
Regulator Voltage	V_{REG}		890	950	1000	mV
Power Supply Rejection Ratio	PSRR		49	57	-	dB
AGC						
Maximum Threshold (Output Referred)	TH_{MAX}	$V_{IN} = -60$ dBV Note 2	-43	-41	-39	dBV
Minimum Threshold (Output Referred)	TH_{MIN}	$V_{IN} = -70$ dBV $R_{TH} = 200$ k Note 2	-59	-57	-55	dBV
VC Gain Range	ΔA_{VC}	$R_{VC} = 200$ k Ω to 0Ω	35	38	41	dB
Compression Ratio High Threshold	CMP-H	$V_{IN} = -60$ dBV to -30 dBV $R_{TH} = 0$	8	9.0	10	ratio
Compression Ratio Low Threshold	CMP-L	$V_{IN} = -70$ dBV to -40 dBV $R_{TH} = 200$ k	6.5	7.3	9	ratio
Stage A Gain	A_A	$V_{IN} = -70$ dBV	24	27	30	dB
Compression Gain Range	A_{RANGE}	$R_{TH} = 200$ k; Note 1	47	50	55	dB
AGC Time Constant	τ_{AGC}		-	270	-	ms
OUTPUT STAGE						
Gain	A_B		9	11	13	dB
Output Resistance			20	24	28	k Ω

All parameters and switches remain as shown in the Test Circuit unless otherwise stated in CONDITIONS column.

Note 1. $A_{RANGE} = A_A - A_A [V_{IN} = -20$ dBV]

2. Measured at output of Stage A

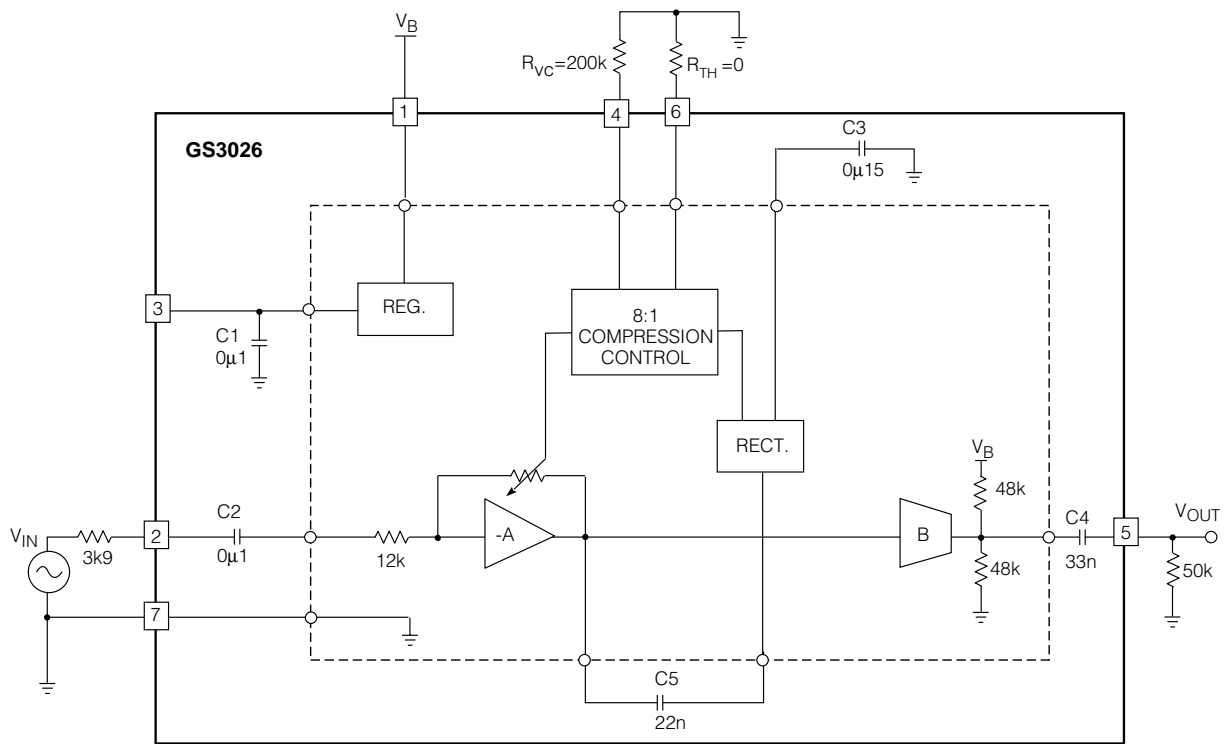

All resistors in ohms, all capacitors in farads unless otherwise stated.

Fig. 1 Production Test Circuit

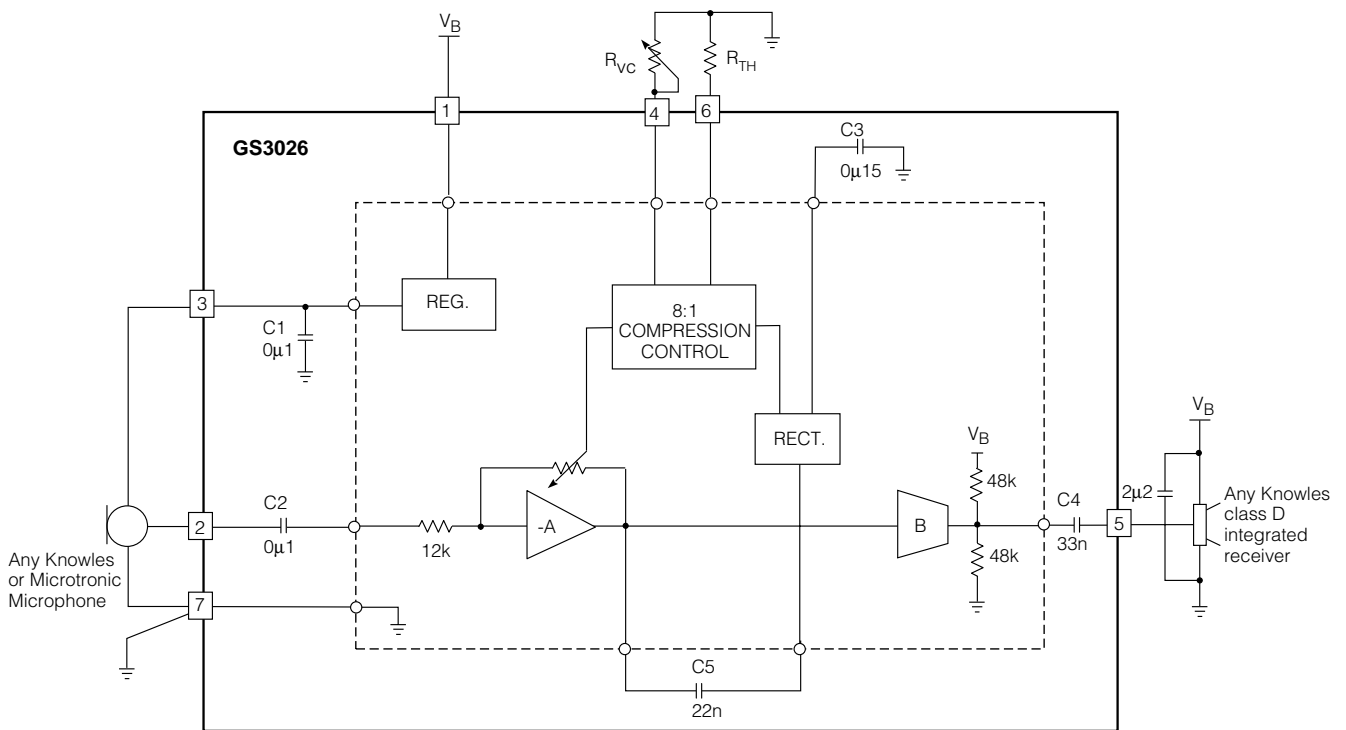

All resistors in ohms, all capacitors in farads unless otherwise stated.

Fig. 2 Typical Hearing Instrument Application

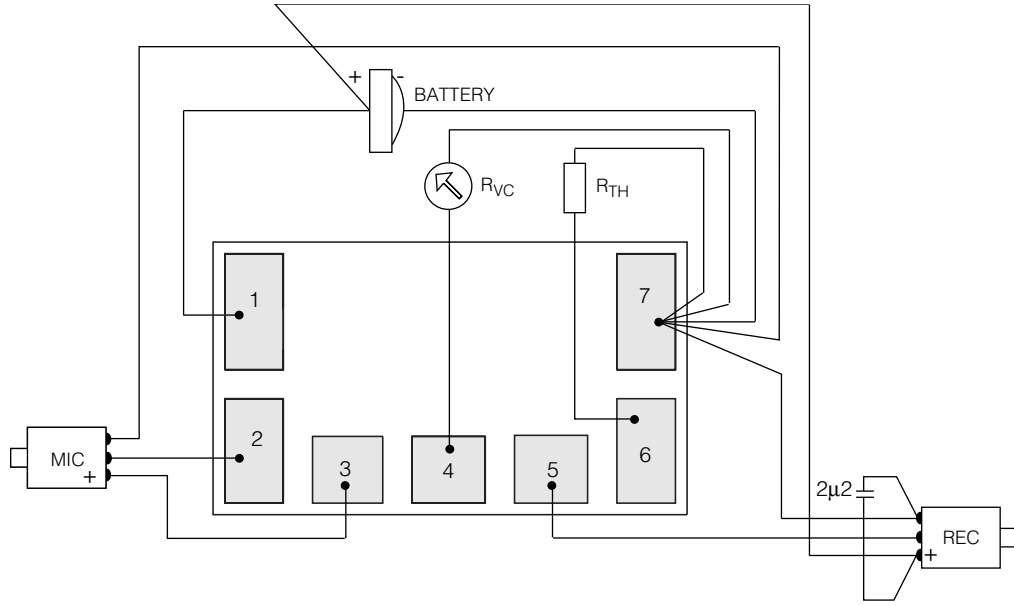
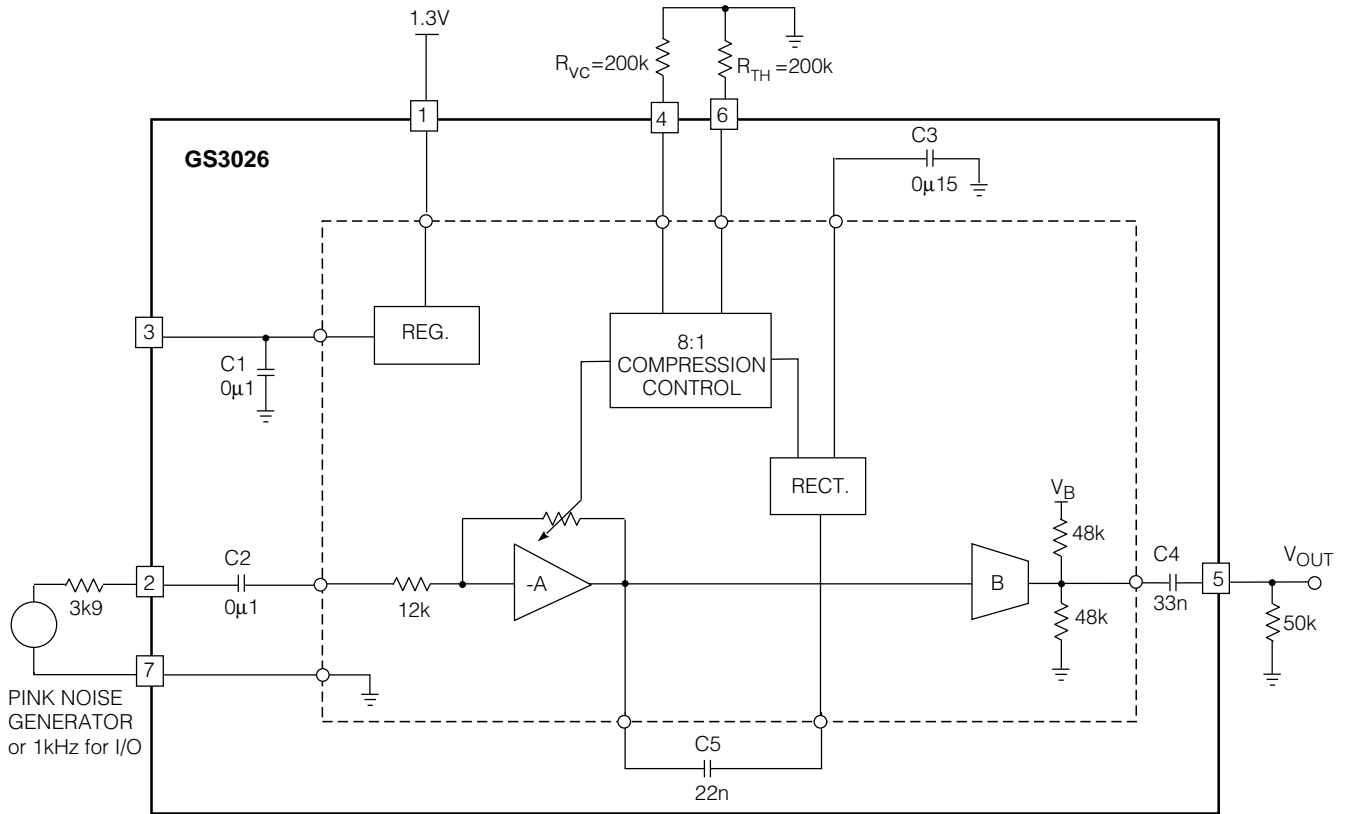

Fig. 3 Typical Hearing Instrument Assembly Diagram



All resistors in ohms, all capacitors in farads unless otherwise stated.

Fig. 4 Characterization Circuit (used to generate Typical Curves)

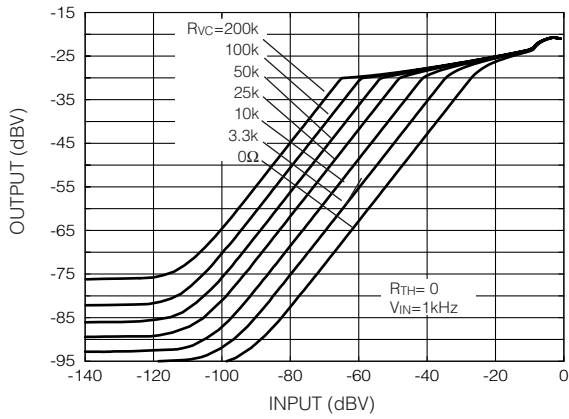

Fig. 5 Input vs Output Volume Control Settings

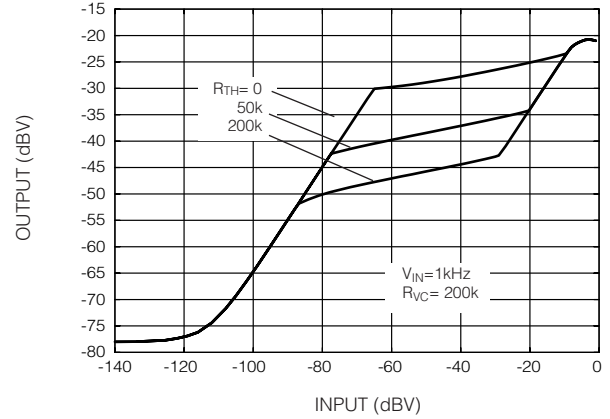

Fig. 6 Input vs Output Threshold Settings

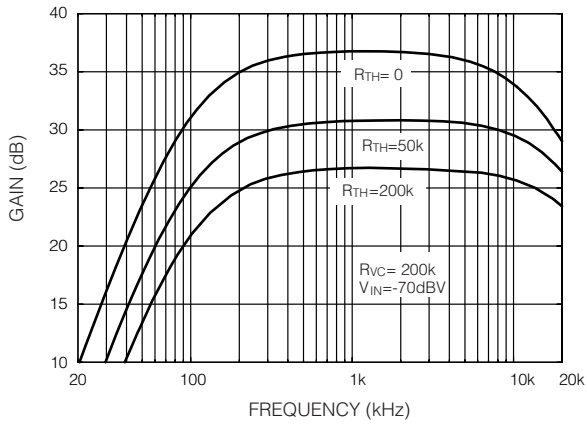

Fig. 7 Frequency Response vs R_{TH}

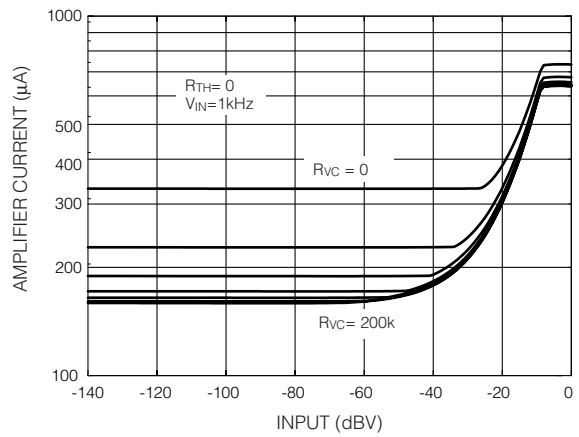

Fig. 8 Amplifier Current vs R_{VC}

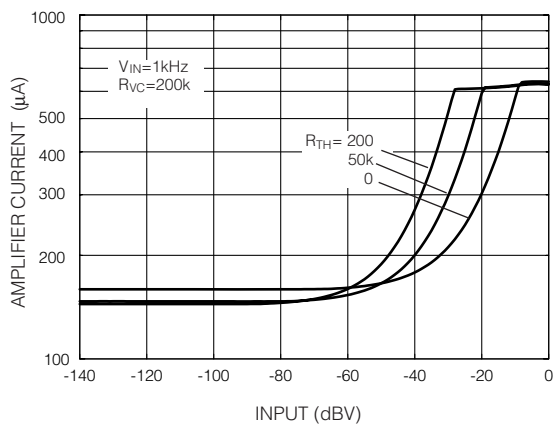

Fig. 9 Amplifier Current vs R_{TH}

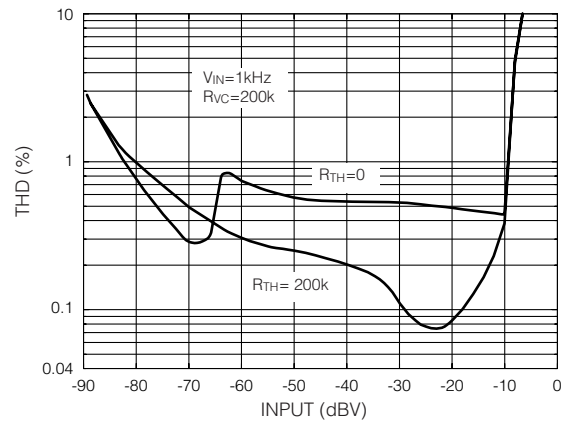

Fig. 10 THD vs Input

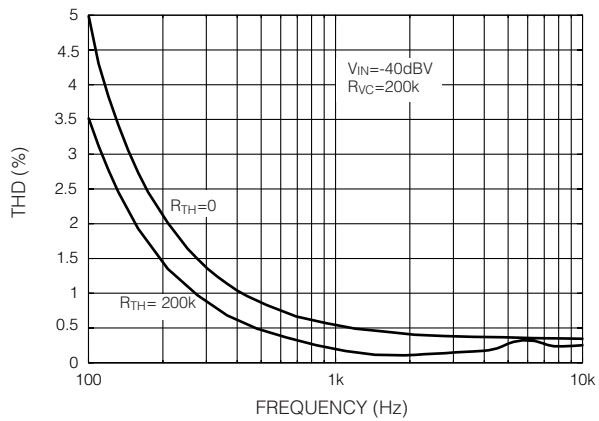

Fig. 11 THD vs Frequency

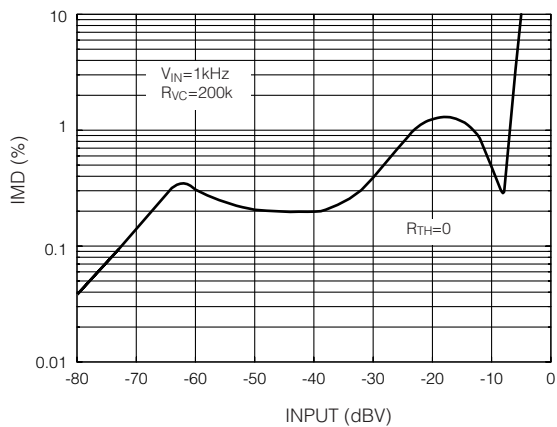

Fig. 12 Intermodulation Distortion vs Input

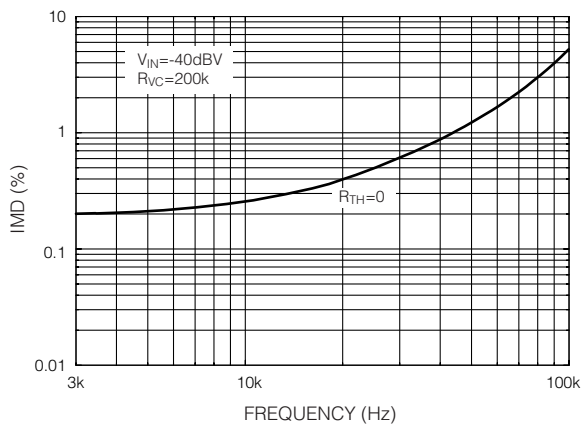
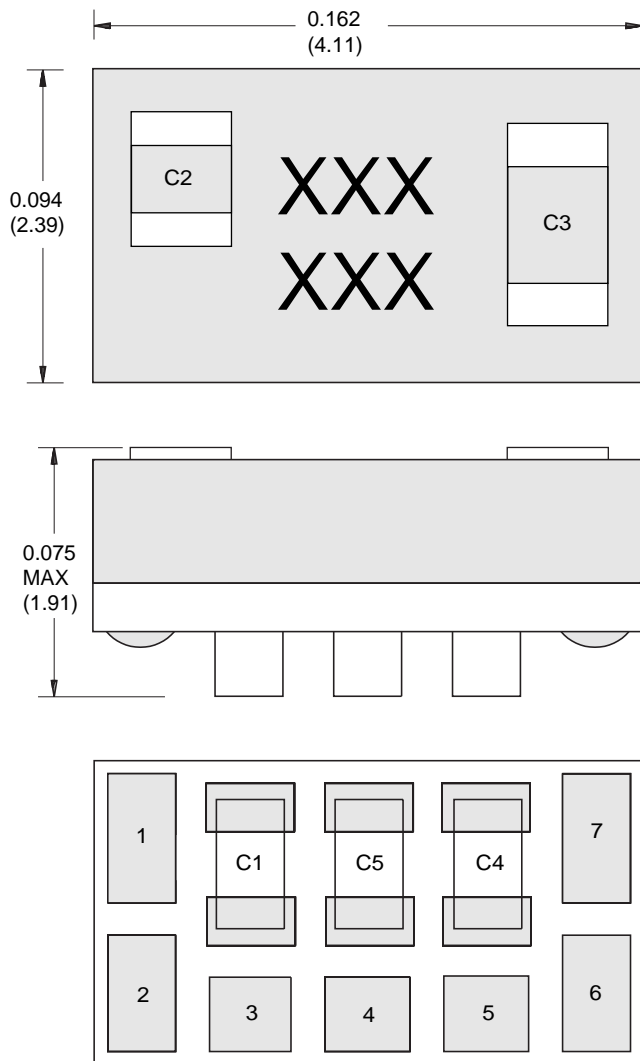

Fig. 13 Intermodulation Distortion vs Frequency



Dimensioning units are inches.
 Dimensions shown in parenthesis are in millimetres, converted from inches and include minor round off errors.
 1.0000 inches = 25.400mm.
 Dimension tolerances ± 0.003 (+0.08) unless otherwise stated.
 Pad numbers and capacitor numbers for illustration only.
 Smallest pad sizes 0.024 x 0.023 (0.61 x 0.58).
 Largest pad size 0.020 x 0.040 (0.51 x 1.02).
 XXXXXX - work order number.
 This hybrid is designed for point to point manual soldering.
 For more information contact Gennum Corporation.

Fig. 14 Hybrid Layout and Dimensions

DOCUMENT IDENTIFICATION: DATA SHEET
 The product is in production. Gennum reserves the right to make changes at any time to improve reliability, function or design, in order to provide the best product possible.

REVISION NOTES:
 Updated to Data sheet, corrections to TH_{MAX} and TH_{MIN}