

Features

- Ultra Low Quiescent Current: 11uA (Typ.)
- Wide Operating Voltage: 6~40V
- ±2% Initial Voltage Accuracy
- Fixed Output Voltage: 1.8V ~ 13V or Adjustable Voltage
- Programmable Discharge
- Programmable Soft-Start
- Build-In OTP
- Build-In OCP
- Short Circuit Current Fold-back
- PSOP-8, SOT-23-5, SOT-23-6, SOT-89-3, TDFN6-2x2 package
- Green Product (RoHS, Lead-Free, Halogen-Free Compliant)

General Description

The GS7138 is a low quiescent current CMOS linear regulator, which operates with input voltage from 6V to 40V and delivers output current up to 150mA. The linear regulator includes essential features for the applications of portable devices with high voltage batteries, especially for supplying the always-on, keep-alive power circuitries.

Applications

- Portable/battery powered equipments
- Electronic sensors
- Microcontroller power
- Real time clock backup power

Typical Application

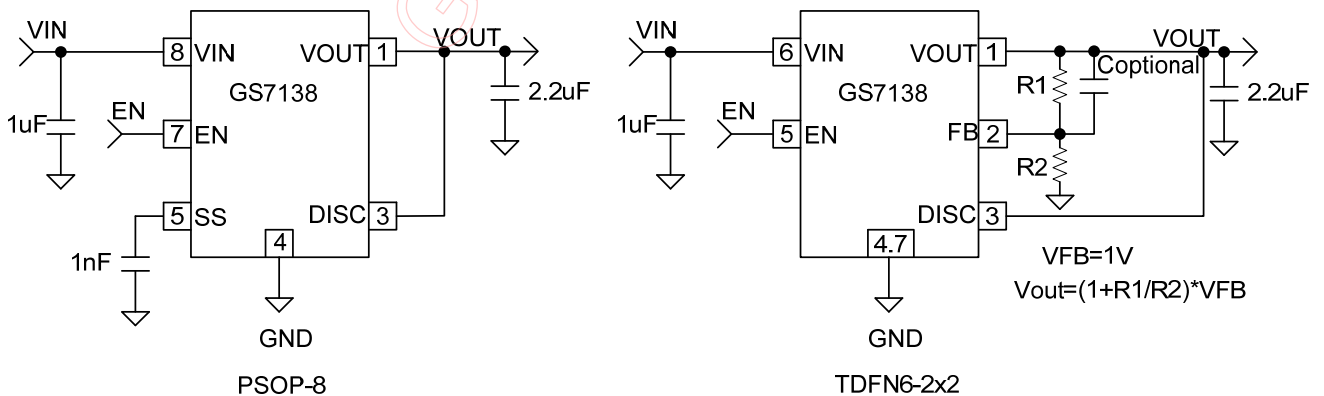
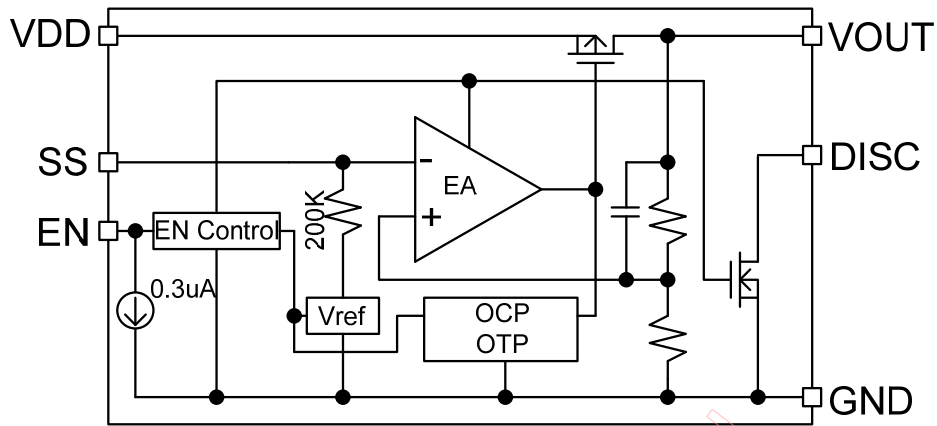

Figure 1 Typical Application of GS7138

This document is GStek's confidential information. Anyone having confidential obligation to GStek shall keep this document confidential. Any unauthorized disclosure or use beyond authorized purpose will be considered as violation of confidentiality and criminal and civil liability will be asserted.

Function Block Diagram



(a) FIX Output Voltage

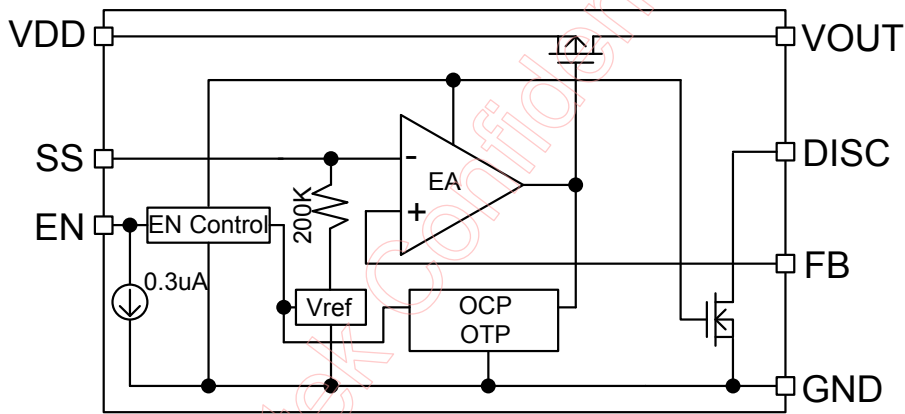

(b) ADJ Output Voltage

Figure 2 Function Block Diagram

Pin Configuration

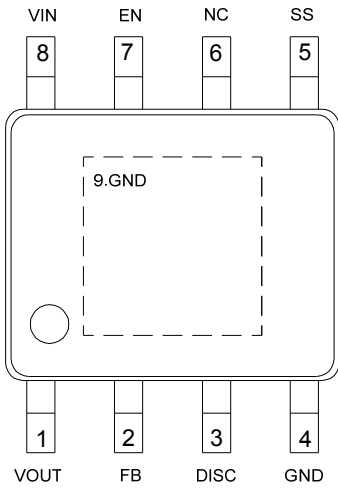

Figure 3a PSOP-8 package

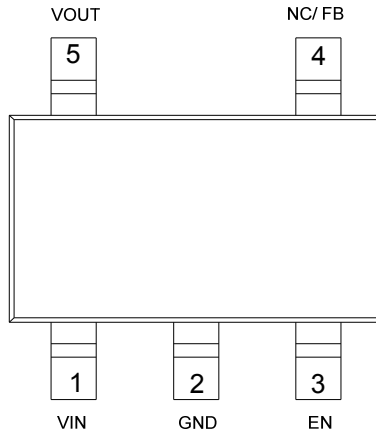

Figure 3b SOT-23-5(S5) package

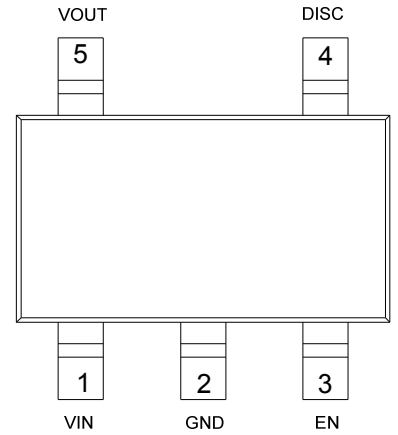

Figure 3c SOT-23-5(S2) package

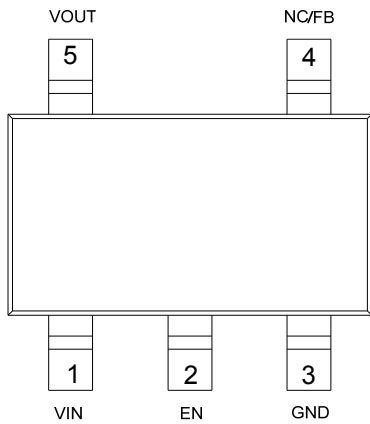

Figure 3d SOT-23-5(S3) package

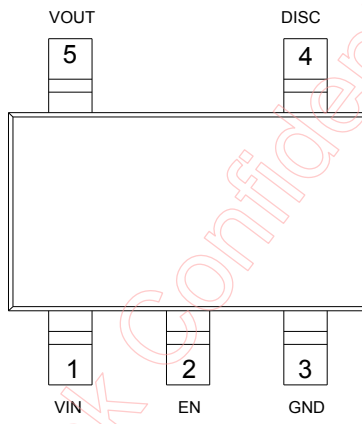

Figure 3e SOT-23-5(S1) package

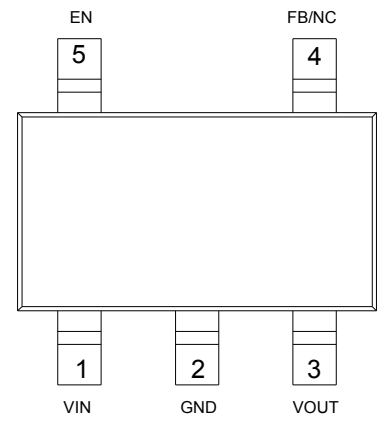

Figure 3f SOT-23-5(SX) package

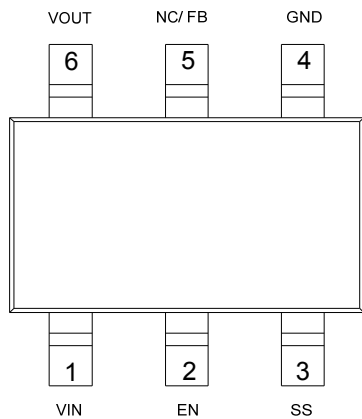

Figure 3g SOT-23-6(ST) package

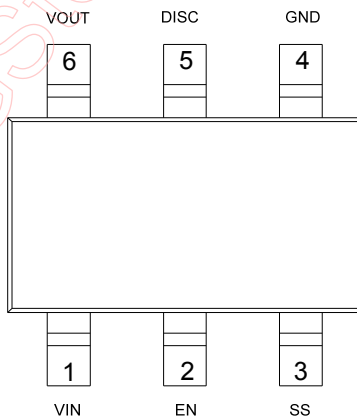

Figure 3h SOT-23-6(S6) package

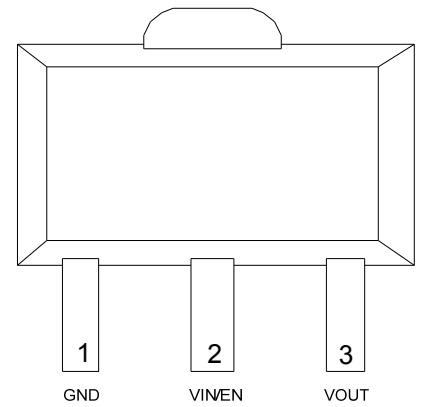

Figure 3i SOT-89-3(S9) package

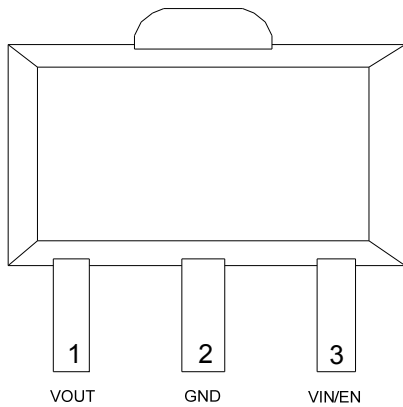

Figure 3j SOT-89-3(S8) package

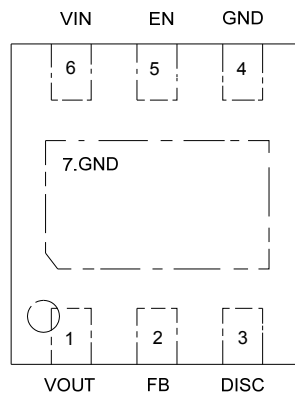

Figure 3kTDFN6-2x2(TD) package

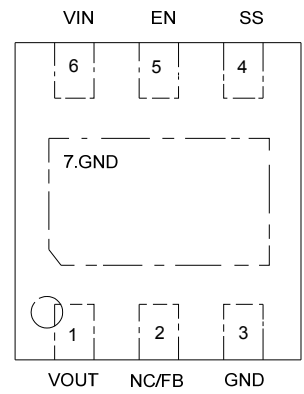

Figure 3lTDFN6-2x2(D6) package

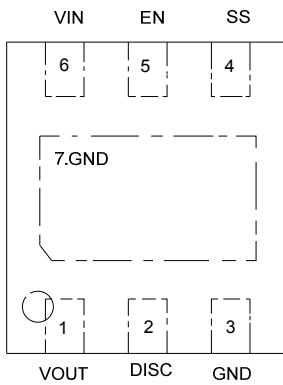
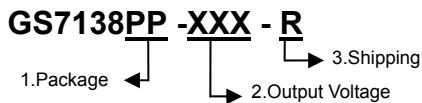

Figure 3mTDFN6-2x2(D2) package

Pin Descriptions

PSOP-8	No.												Name	I/O type	Pin Function
	SOT-23-5					SOT-23-6		SOT-89-3		TDFN6-2x2					
	S1	S2	S3	S5	SX	ST	S6	S8	S9	TD	D2	D6			
1	5	5	5	5	3	6	6	1	3	1	1	1	VOUT	O	Output Voltage
2			4	4	4	5				2		2	FB	I	Feedback Voltage
3	4	4					5			3	2		DISC	O	Auto-Discharge, connect to VOUT
4,9	3	2	3	2	2	4	4	2	1	4,7	3,7	3,7	GND	I/O	Ground
5						3	3				4	4	SS	O	Soft start
6			4	4	4	5						2	NC		
7	2	3	2	3	5	2	2	3	2	5	5	5	EN	I	Chip Enable, Active High
8	1	1	1	1	1	1	1	3	2	6	6	6	VIN	I	Power Input

Ordering Information



No	Item	Contents
1	Package	SO: PSOP-8 S1:SOT-23-5 S2:SOT-23-5 S3:SOT-23-5 S5:SOT-23-5 SX:SOT-23-5 ST:SOT-23-6 S6:SOT-23-6 S8:SOT-89-3 S9:SOT-89-3 TD:TDFN6-2x2 D6:TDFN6-2x2 D2:TDFN6-2x2
2	Output Voltage	ADJ: ADJ, 3P3: 3.3V, 3P5: 3.5V, 5P0: 5V, 012:12V, 013:13V
3	Shipping	R: Tape & Reel

Example: GS7138 PSOP-8 ADJ Tape & Reel ordering information is “GS7138SO-ADJ-R”

Absolute Maximum Rating (Note 1)

Parameter	Symbol	Limits	Units
VIN to GND	V _{IN}	-0.3 ~ 43	V
Output Voltage	V _{OUT}	-0.3 ~ 43	V
FB and SS Voltage		-0.3 ~ 6	V
EN and DISC Voltage		-0.3 ~ 43	V
Package Power Dissipation at T _A ≤ 25°C	P _{D_PSOP-8}	1333	mW
Package Power Dissipation at T _A ≤ 25°C	P _{D_SOT-23-5}	400	mW
Package Power Dissipation at T _A ≤ 25°C	P _{D_SOT-23-6}	420	mW
Package Power Dissipation at T _A ≤ 25°C	P _{D_SOT-89-3}	571	mW
Package Power Dissipation at T _A ≤ 25°C	P _{D_TDFN6-2x2}	1087	mW

Junction Temperature	T_J	- 45 ~ 150	°C
Storage Temperature	T_{STG}	- 65 ~ 150	°C
Lead Temperature (Soldering) 10S	T_{LEAD}	260	°C
ESD (Human Body Mode) (Note 2)	V_{ESD_HBM}	2K	V
ESD (Machine Mode) (Note 2)	V_{ESD_MM}	200	V

Thermal Information (Note 2)

Parameter	Symbol	Limits	Units
Thermal Resistance Junction to Ambient	θ_{JA_PSOP-8}	75	°C/W
Thermal Resistance Junction to Ambient	$\theta_{JA_SOT-23-5}$	250	°C/W
Thermal Resistance Junction to Ambient	$\theta_{JA_SOT-23-6}$	238	°C/W
Thermal Resistance Junction to Ambient	$\theta_{JA_SOT-89-3}$	182	°C/W
Thermal Resistance Junction to Ambient	$\theta_{JA_TDFN6-2x2}$	92	°C/W

Recommend Operating Condition (Note 3)

Parameter	Symbol	Limits	Units
VIN to GND	V_{IN}	6 ~ 40	V
VOOUT to GND	V_{OUT}	1.8 ~ 30	V
FB and SS to GND		0 ~ 5.5	V
EN and Disc to GND		0 ~ 40	V
Junction Temperature	T_J	- 40 ~ 125	°C
Ambient Temperature	T_A	- 40 ~ 85	°C

Electrical Characteristics

($C_{IN}=1\mu F$, $C_O=2.2\mu F$, $V_{IN}=\text{MAX}\{V_{O(NOM)}+2.5V, 6V\}$, $T_A = 25^\circ C$, $I_O=1mA$, unless otherwise specified)

Parameter	Symbol	Test Conditions	Min	Typ	Max	Units	
Input Voltage	V_{IN}	$I_O=20mA, V_{O(NOM)}=3.3V$	6.0		40	V	
		$I_O=50mA, V_{O(NOM)}=3.3V$	7.2		40		
		$I_O=100mA, V_{O(NOM)}=3.3V$	8.6		40		
		$I_O=150mA, V_{O(NOM)}=3.3V$	9.8		40		
Output Voltage Range		FIX	1.8		13	V	
Output Voltage Accuracy	V_{out}		-2		+2	%	
Reference Voltage	V_{ref}		0.98	1	1.02	V	
Quiescent Current	I_Q	$V_{IN}=\text{MAX}\{V_{O(NOM)}+2.5V, 6V\}, I_O=1mA$		11	22	μA	
Load Current Range	I_{out}	$V_{IN}>9V$	0		150	mA	
Load Regulation	REG load	$1mA < I_O < 150mA$, $V_{IN}=\text{MAX}\{V_{O(NOM)}+2.5V, 10V\}$		0.1	1	%	
Line Regulation	REG line	$V_{IN}=\text{MAX}\{V_{O(NOM)}+2.5V, 6V\}$ to 40V, $I_O=1mA$		0.01	0.2	%	
Dropout Voltage (Note 4)	V_{DROP}	$I_O=20mA$	$V_{O(NOM)}=3.3V$		1.93	2.70	V
			$V_{O(NOM)}=5.0V$		0.65	1.10	V
			$V_{O(NOM)}=12.0V$		0.19	0.25	V
		$I_O=50mA$	$V_{O(NOM)}=3.3V$		2.86	3.90	V
			$V_{O(NOM)}=5.0V$		1.54	2.20	V
			$V_{O(NOM)}=12.0V$		0.51	0.60	V
		$I_O=100mA$	$V_{O(NOM)}=3.3V$		4.02	5.30	V
			$V_{O(NOM)}=5.0V$		2.86	3.50	V
			$V_{O(NOM)}=12.0V$		1.00	1.20	V
		$I_O=150mA$	$V_{O(NOM)}=3.3V$		4.97	6.50	V
			$V_{O(NOM)}=5.0V$		3.63	4.60	V
			$V_{O(NOM)}=12.0V$		1.61	1.80	V
Circuit Current Limit	I_{limit}	$V_{IN} = \text{MAX}\{V_{O(NOM)}+2.5V, 10V\}$	180	320	450	mA	
Short Current	I_{short}	$V_O < 0.5 * V_{O(NOM)}$		26		mA	
Power supply rejection	PSRR	$V_{ripple}=0.1V, I_O=20mA, f=100Hz$		50		dB	
Thermal shutdown	OTP			170		$^\circ C$	
Return temperature	OTH			125		$^\circ C$	
Soft-Start Interval (Figure 4)	T_{ss}	From enable start to $0.9 * V_{O(NOM)}$ (FIX), $C_{SS}=NC$	0.3	0.7	1.5	ms	
Input High Voltage	V_{ENH}		2.5			V	
Input Low Voltage	V_{ENL}				0.6	V	
EN Pin Input Bias Current	I_{EN}	$V_{EN}=25V$		0.3	0.9	μA	
Shutdown Supply Current	I_{qshut}	$V_{EN}=0, V_{IN}=40V$		0.1	1	μA	
Auto-Discharge Resistance	R_{dischg}	$V_{EN}=0, V_{IN}=20V$	75	83	115	Ω	

Note 1. Stresses listed as the above “Absolute Maximum Ratings” may cause permanent damage to the device. These are for stress ratings. Functional operation of the device at these or any other conditions beyond those indicated in the operational sections of the specifications is not implied. Exposure to absolute maximum rating conditions for extended periods may remain possibility to affect device reliability.

Note 2. Devices are ESD sensitive. Handling precaution recommended.

Note 3. The device is not guaranteed to function outside its operating conditions.

Note 4. The dropout voltage is defined as $V_{IN}-V_{OUT}$, which is measured when V_{OUT} is $98\% \times V_{O}$.

The dropout voltage is measured at constant junction temperature by using a 2ms current pulse.

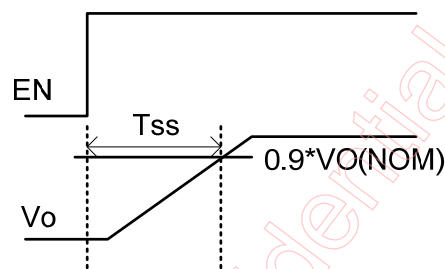
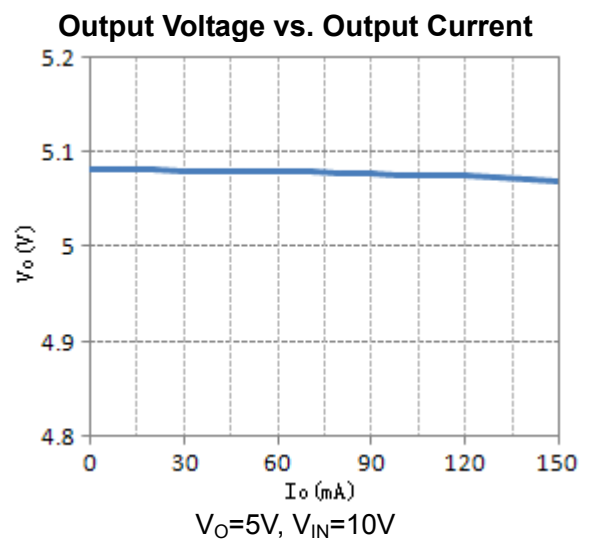
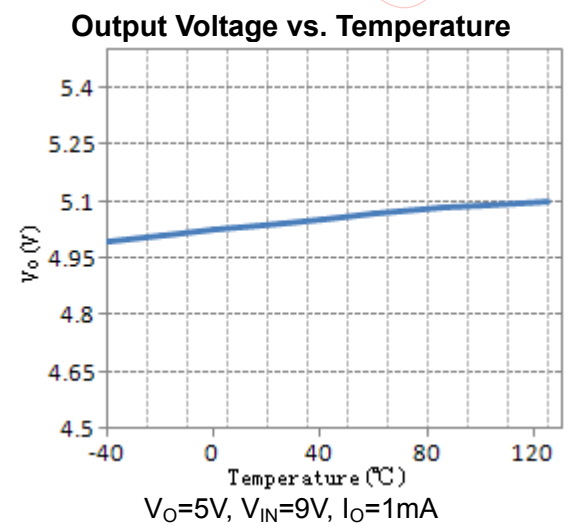
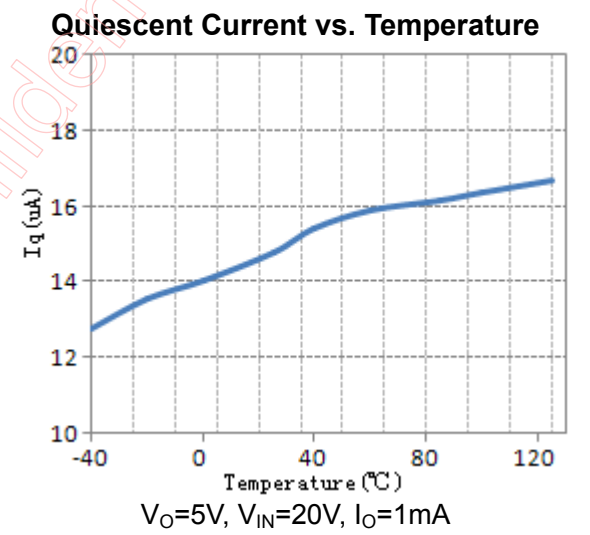
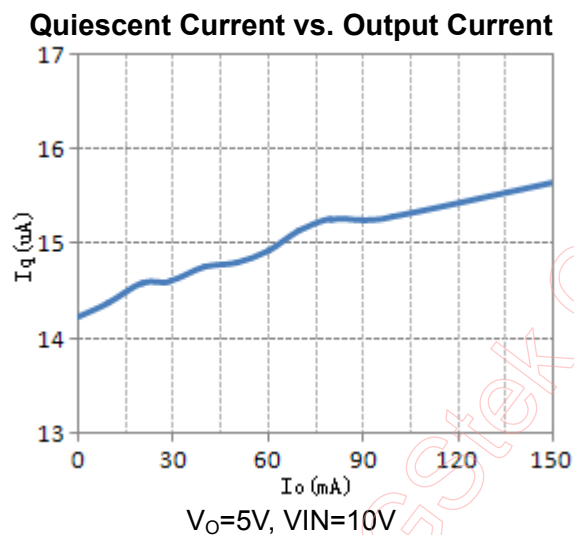
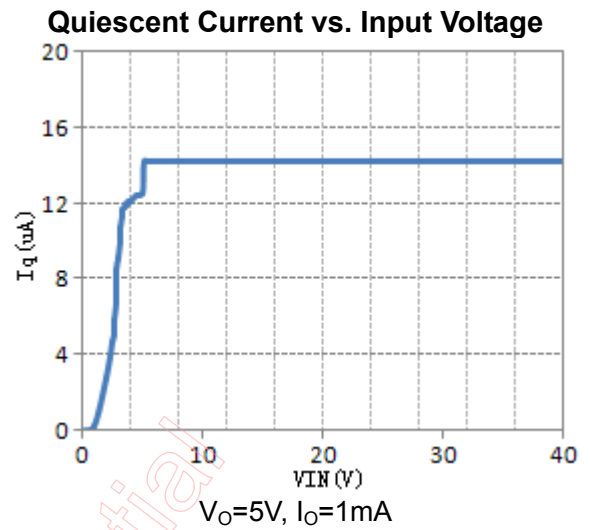
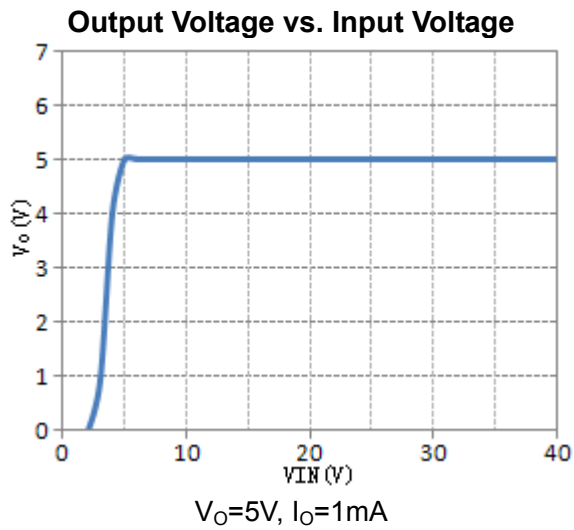
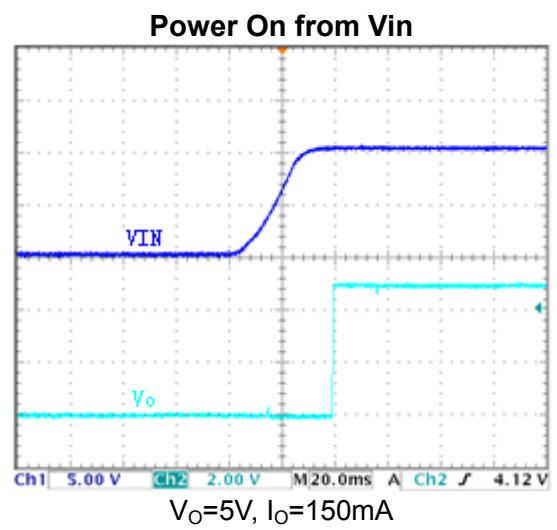
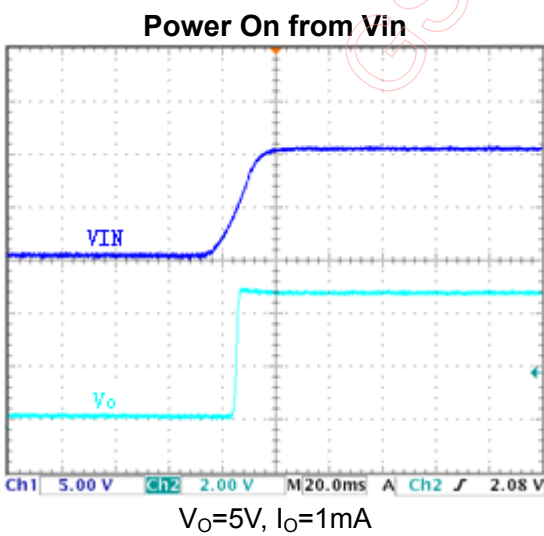
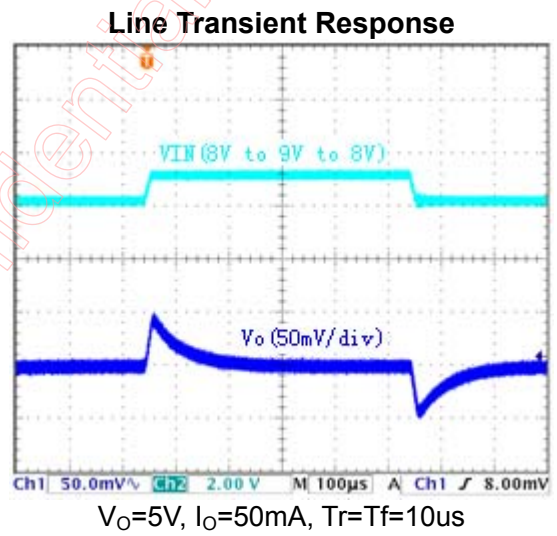
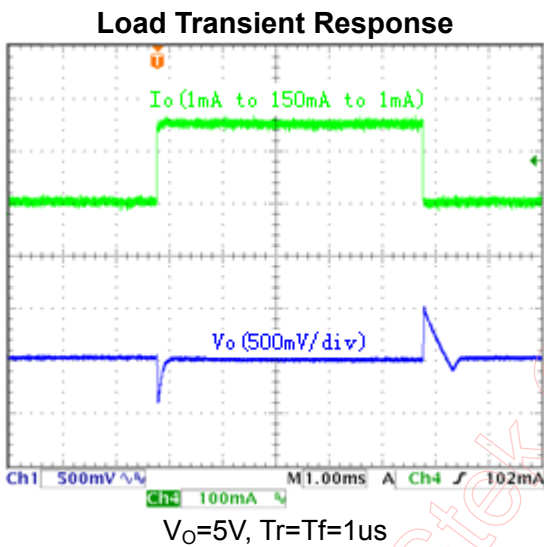
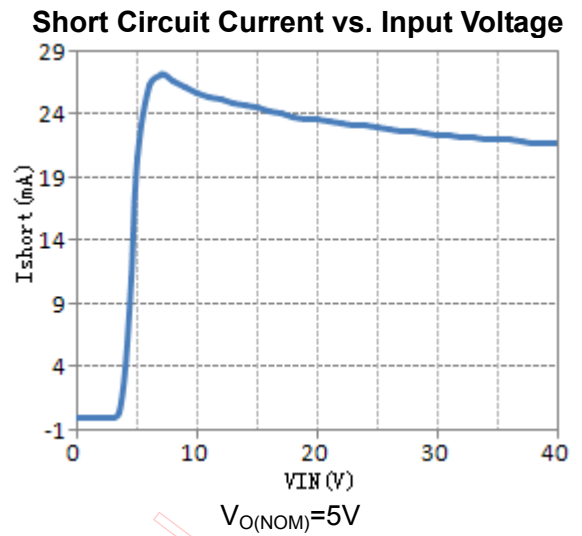
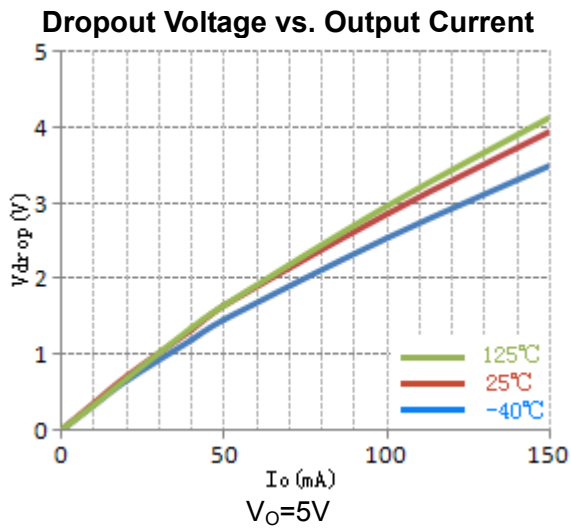

Figure 4 Soft-Start Interval

Typical Characteristics

($V_{IN} = \text{MAX}\{V_{O(NOM)} + 2.5V, 10V\}$, $I_O = 1mA$, $C_{IN} = 1\mu F$, $C_O = 2.2\mu F$, $T_A = 25^\circ C$ unless otherwise specified)





Power On from EN

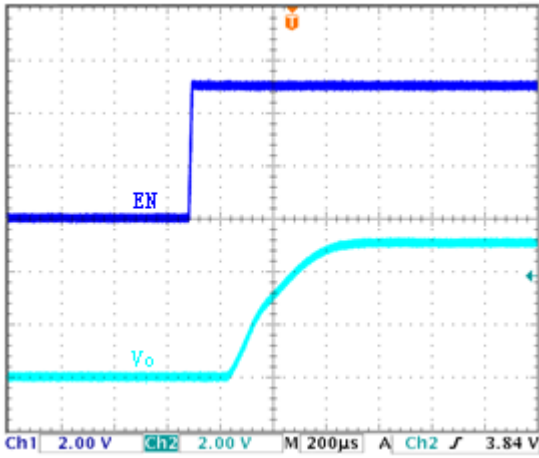

$V_o=5V, I_o=1mA$

Power On from EN

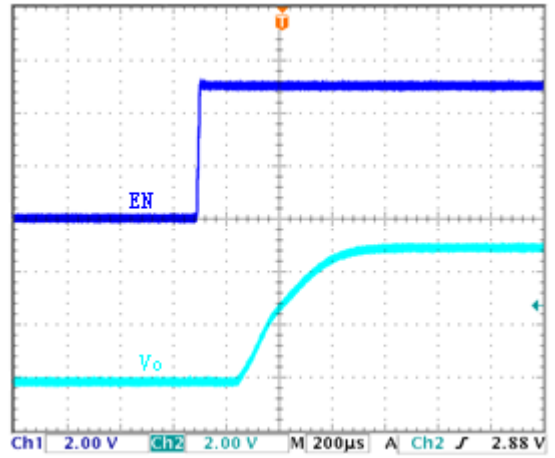

$V_o=5V, I_o=150mA$

Power Off from EN

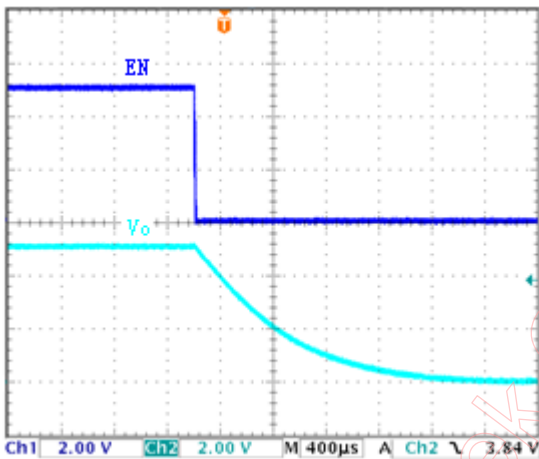

$V_o=5V, I_o=1mA$

Power Off from EN

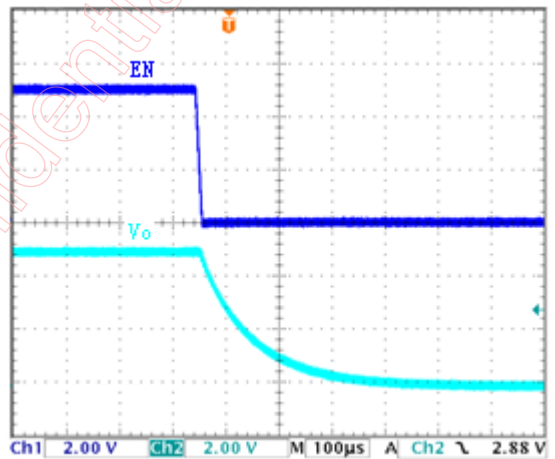

$V_o=5V, I_o=150mA$

Application Information

Enable

The GS7138 has a dedicated enable pin(EN). When the EN pin is in the logic low ($V_{EN}<0.6V$), the regulator will be turned off, reducing the supply current to less than 1uA.

When the EN pin is in the logic high ($V_{EN}>2.5V$), the regulator will be turned on and undergoes a new soft-start cycle. Left open, the EN pin is pulled down by a internal current source to shut down the regulator.

Build-In Soft-Start

An internal soft-start function controls rise rate of the output voltage to limit the current surge at start-up. The Soft-start interval from Enable start to $0.9 \times V_{O(NOM)}$, as Figure 4.

For ADJ output voltage application, Tss Calculator as Follow

	$C_{SS} \leq 1.5nF$	$C_{SS} > 1.5nF$	Unit
T_{SS}	0.7	$4.75 \times 10^8 \times C_{SS}$	ms

For FIX output voltage application, Tss Calculator as Follow

	$C_{SS} \leq 1.3nF$	$C_{SS} > 1.3nF$	Unit
T_{SS}	0.7	$5.25 \times 10^8 \times C_{SS}$	ms

Current Limit

The GS7138 contains a foldback over current protection function. It allows the output current to reach the maximum value of 320mA. Then further decreases in the load resistance reduce both the load current and the load voltage. The main advantage of foldback limiting is less power dissipation in the pass transistor under shorted-load conditions. During startup, the current limit value is set to a high value, thus GS7138 can operate in full load condition. After startup, the current limit value is set to a normal value, so the pass transistor can be protected well.

Thermal-Shutdown Protection

Thermal Shutdown protects GS7138 from excessive power dissipation. If the die temperature exceeds 150°C, the pass transistor is shut off. 25°C of hysteresis prevents the regulator from turning on until the die temperature drops to 125°C.

Output Capacitor selection

The GS7138 is specifically designed to employ ceramic output capacitors as low as 2.2uF. Place the capacitors physically as close as possible to the device with wide and direct PCB traces.

Input Capacitor selection

Bypass V_{IN} to ground with a 1uF or greater capacitor. Place the capacitors physically as close as possible to the device with wide and direct PCB traces.

Thermal Considerations

Although internal thermal limiting function is integrated in GS7138, continuously keeping the junction near the thermal shutdown temperature may possibly affect device reliability. For continuous operation, it is highly recommended to keep the junction temperature below the maximum operation junction temperature 125°C for maximum reliability. The power dissipation definition in device is:

$$P_D = (V_{IN} - V_{OUT}) \times I_{OUT} + V_{IN} \times I_Q$$

The maximum power dissipation depends on the thermal resistance of IC package, PCB layout, the rate of surroundings airflow and temperature difference between junction to ambient. The maximum power dissipation can be calculated by following formula:

$$P_{D(MAX)} = (T_{J(MAX)} - T_A) / \theta_{JA}$$

Where $T_{J(MAX)}$ is the maximum operation junction temperature $125^{\circ}C$, T_A is the ambient temperature and the θ_{JA} is the junction to ambient thermal resistance.

For recommended operating conditions specification of GS7138, where $T_{J(MAX)}$ is the maximum junction temperature of the die ($125^{\circ}C$) and T_A is the maximum ambient temperature. The junction to ambient thermal resistance (θ_{JA} is layout dependent) for SOT-89-3 package is $162^{\circ}C/W$ and SOT-23-5 package is $250^{\circ}C/W$ on standard JEDEC 51-3 thermal test board. The maximum power dissipation at $T_A = 25^{\circ}C$ can be calculated by following formula:

$$P_{D(MAX)} = (125^{\circ}C - 25^{\circ}C)/162 = 617mW \text{ (SOT-89-3)}$$

$$P_{D(MAX)} = (125^{\circ}C - 25^{\circ}C)/250 = 400mW \text{ (SOT-23-5)}$$

The maximum power dissipation depends on operating ambient temperature or fixed $T_{J(MAX)}$ and thermal resistance θ_{JA} . For GS7138 packages, the Figure 5. of derating curves allows the designer to see the effect of rising ambient temperature on the maximum power allowed.

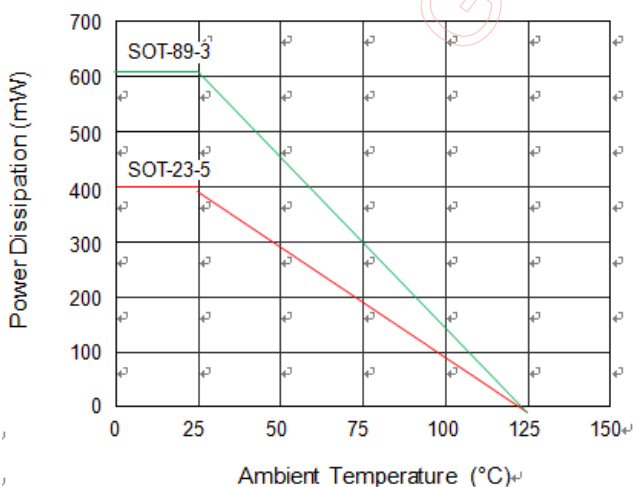
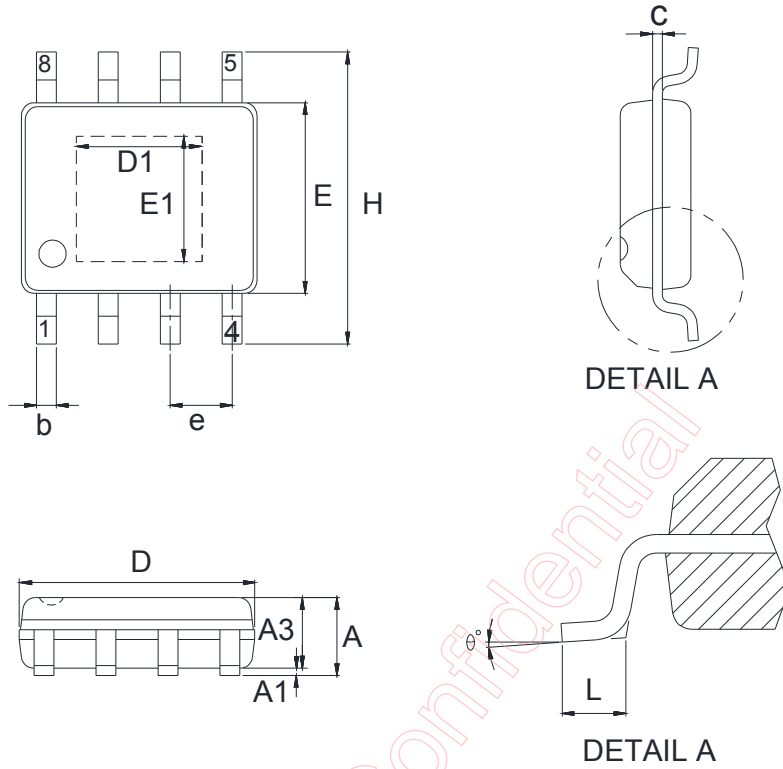

Figure 5 Derating Curve for Packages

Package Dimensions, PSOP-8(B)



Symbol	Dimensions in Millimeters	
	Min.	Max.
A	1.30	1.80
A1	-	0.15
A3	1.25	-
b	0.31	0.51
c	0.17	0.25
e	1.27 REF.	
D	4.70	5.10
E	3.80	4.00
D1	3.1 REF.	
E1	2.3 REF.	
H	5.80	6.20
L	0.40	1.27
θ	0°	8°

Note:

- 1. Min.: Minimum dimension specified.
- 2. Max.: Maximum dimension specified.
- 3. REF.: Reference. Normal/Regular dimension specified for reference.

Package Dimensions, SOT-23-5

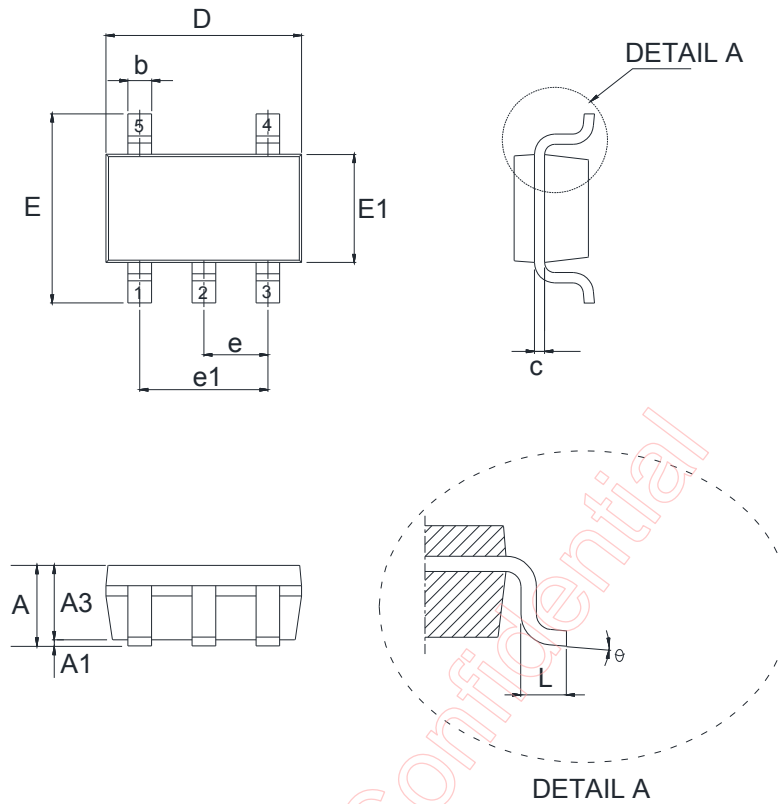

Symbol	Dimensions in Millimeters	
	Min.	Max.
A	0.90	1.45
A1	0.00	0.15
A3	0.90	1.30
b	0.30	0.50
c	0.08	0.25
e	0.95 REF.	
e1	1.90 REF.	
D	2.90 REF.	
E	2.80 REF.	
E1	1.60 REF.	
L	0.30	0.60
θ	0°	8°

Note

- 1.Min.: Minimum dimension specified.
- 2.Max.: Maximum dimension specified.
- 3.REF.: Reference. Normal/Regular dimension specified for reference.

Package Dimensions, SOT-23-6

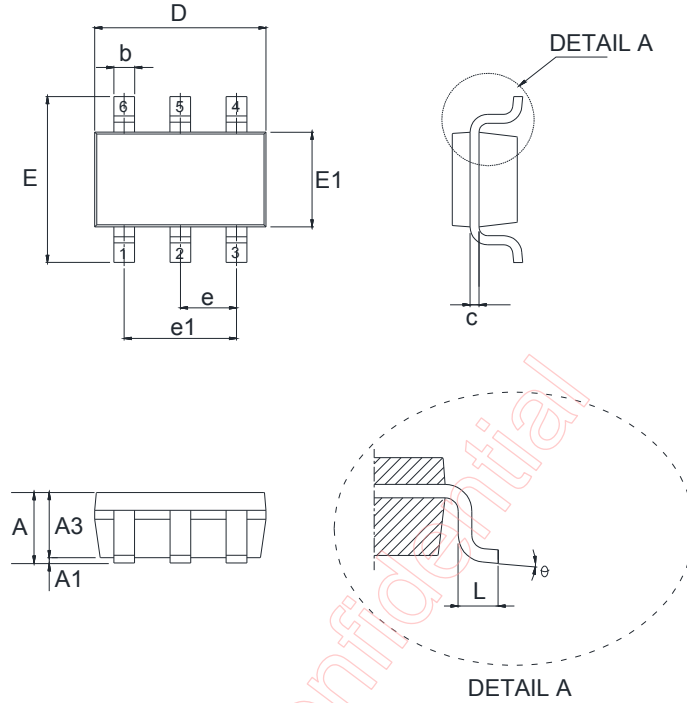

Symbol	Dimensions in Millimeters	
	Min.	Max.
A	0.90	1.45
A1	0.00	0.15
A3	0.90	1.30
b	0.30	0.50
c	0.08	0.25
e	0.95 REF.	
e1	1.90 REF.	
D	2.90 REF.	
E	2.80 REF.	
E1	1.60 REF.	
L	0.30	0.60
θ	0°	8°

Note

- 1.Min.: Minimum dimension specified.
- 2.Max.: Maximum dimension specified.
- 3.REF.: Reference. Normal/Regular dimension specified for reference.

Package Dimensions, TDFN6-2x2

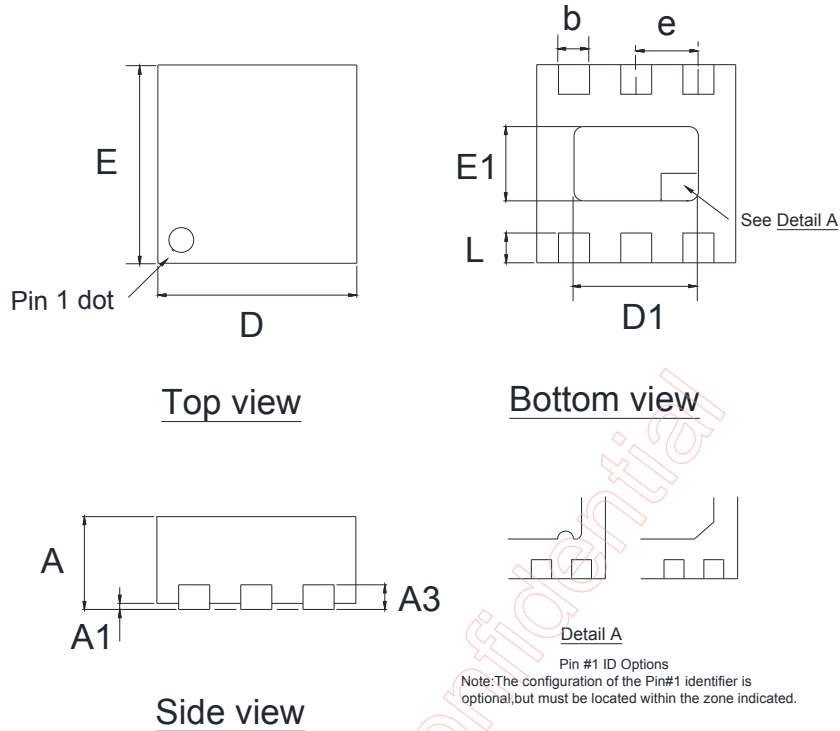

Symbol	Dimensions in Millimeters	
	Min.	Max.
A	0.70	0.80
A1	0.00	0.05
A3	0.203 REF.	
b	0.18	0.35
e	0.65 REF.	
D	1.90	2.10
E	1.90	2.10
D1	1.00	1.45
E1	0.50	0.85
L	0.25	0.45

Note:

1. Min.: Minimum dimension specified.
2. Max.: Maximum dimension specified.
3. REF.: Reference. Normal/Regular dimension specified for reference.

Package Dimensions, SOT-89-3

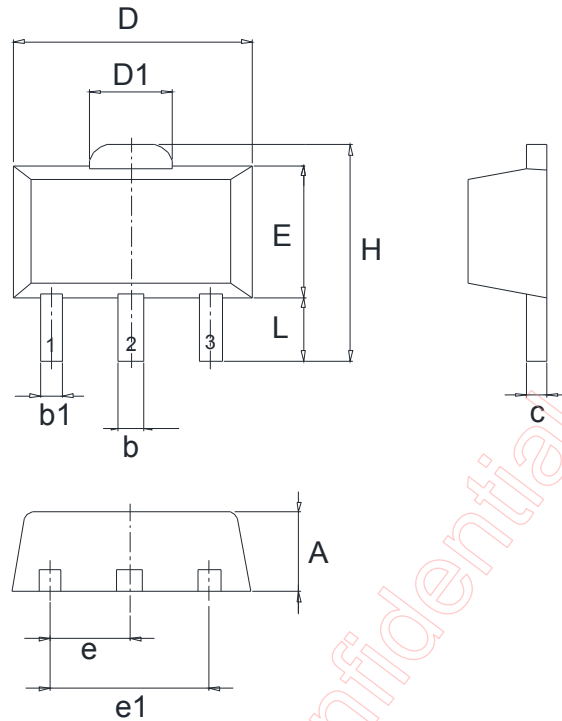

Symbol	Dimensions in Millimeters	
	Min.	Max.
A	1.40	1.60
b	0.40	0.58
b1	0.32	0.52
c	0.35	0.44
e	1.50 REF.	
e1	3.00 REF.	
D	4.40	4.60
D1	1.60 REF.	
E	2.29	2.60
H	3.94	4.25
L	0.80	1.20

Note

- 1.Min.: Minimum dimension specified.
- 2.Max.: Maximum dimension specified.
- 3.REF.: Reference. Normal/Regular dimension specified for reference.

DISCLAIMERS

Please read the notice stated in this preamble carefully before Admission e accessing any contents of the document attached. Admission of GSTek's statement therein is presumed once the document is released to the receiver.

Notice:

Firstly, GREEN SOLUTION CO., LTD. (GStek) reserves the right to make corrections, modifications, enhancements, improvements, and other changes to its information herein without notice.. And the aforesaid information does not form any part or parts of any quotation or contract between GStek and the information receiver.

Further, no responsibility is assumed for the usage of the aforesaid information. GStek makes no representation that the interconnect of its circuits as described herein will not infringe on exiting or future patent rights and other intellectual property rights, nor do the descriptions contained herein express or imply that any licenses under any GStek patent right, copyright, mask work right, or other GStek intellectual property right relating to any combination, machine, or process in which GStek products or services are used.

Besides, the product in this document is not designed for use in life support appliances, devices, or systems where malfunction of this product can reasonably be expected to result in personal injury. GStek customers' using or selling this product for use in such applications shall do so at their own risk and agree to fully indemnify GStek for any damage resulting from such improper use or sale.

At last, the information furnished in this document is the property of GStek and shall be treated as highly confidentiality; any kind of distribution, disclosure, copying, transformation or use of whole or parts of this document without duly authorization from GStek by prior written consent is strictly prohibited. The receiver shall fully compensate GStek without any reservation for any losses thereof due to its violation of GStek's confidential request. The receiver is deemed to agree on GStek's confidential request therein suppose that said receiver receives this document without making any expressly opposition. In the condition that aforesaid opposition is made, the receiver shall return this document to GStek immediately without any delay.