

Features

- 10V~36V Input Voltage Range
- Fixed 5.1V Output Voltage
- Programmable Operation Frequency from 50KHz~300KHz
- Dual Channel Accurate OCP
- COT Control with Internal ripple injection
- Programmable Protection Auto-restart Time
- Build-in Wire Drop Compensation
- Selectable CCM/DEM Operation
- Output Short-Circuit Protection
- Output Over-Voltage Protection
- Output Under-Voltage Protection
- Over Temperature Protection
- QFN23-4x4 Package
- Green Product (RoHS, Lead-Free, Halogen-Free Compliant)

Applications

- Car Charger
- Portable Charger Devices
- Automotive Power Application
- General-Purposed DC-DC Converters

General Description

The GS92D2 is a synchronous Buck converter. Features include wide input voltage range, dual channel accurate OCP, build-in wire drop compensation and auto-restart after protections.

The GS92D2 has fast dynamic transient response with COT control scheme and also has good line and load regulation with internal ripple injection.

The GS92D2 provide dual channel accurate OCP.

When OCP is detected in channel, the output is disabled until ART timing is over, and then the chip will restart automatically, which make sure the safety of whole system. Wire drop compensation is also provided to compensate the voltage loss in cable transmission.

Other protections include over-voltage protection, under-voltage protection, short-circuit protection and over-temperature protection.

The GS92D2 is available in QFN23-4x4 package.

Typical Application

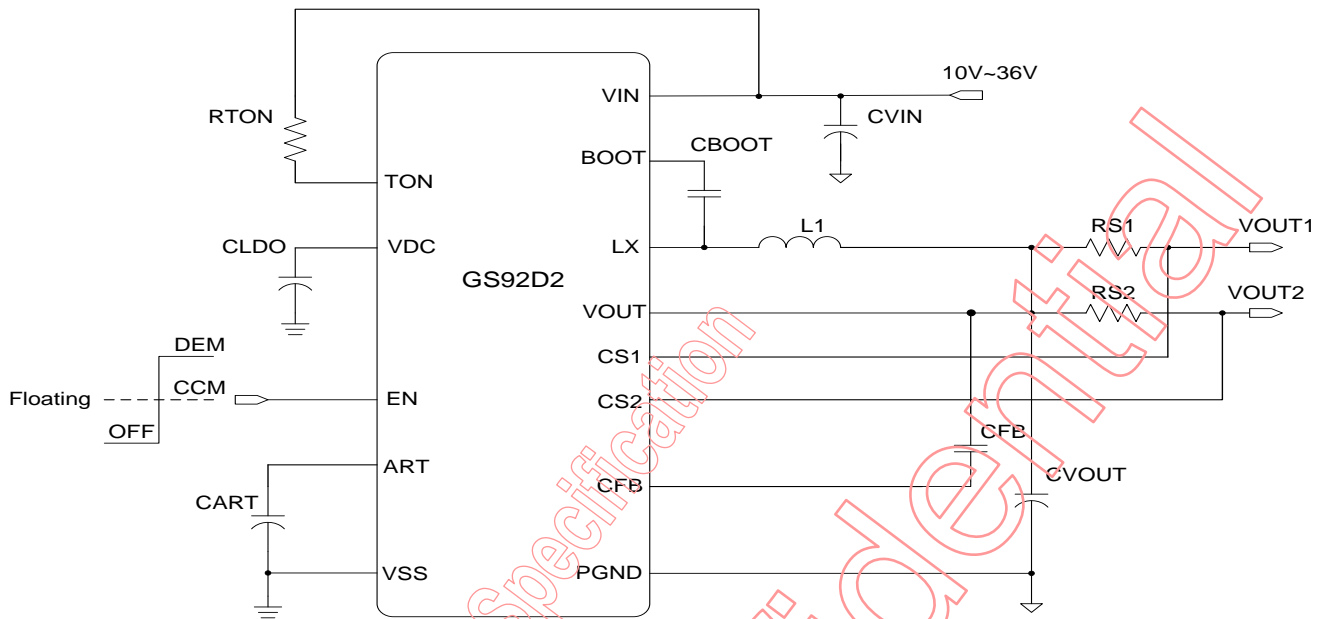

Figure 1 Typical Application of GS92D2

Function Block Diagram

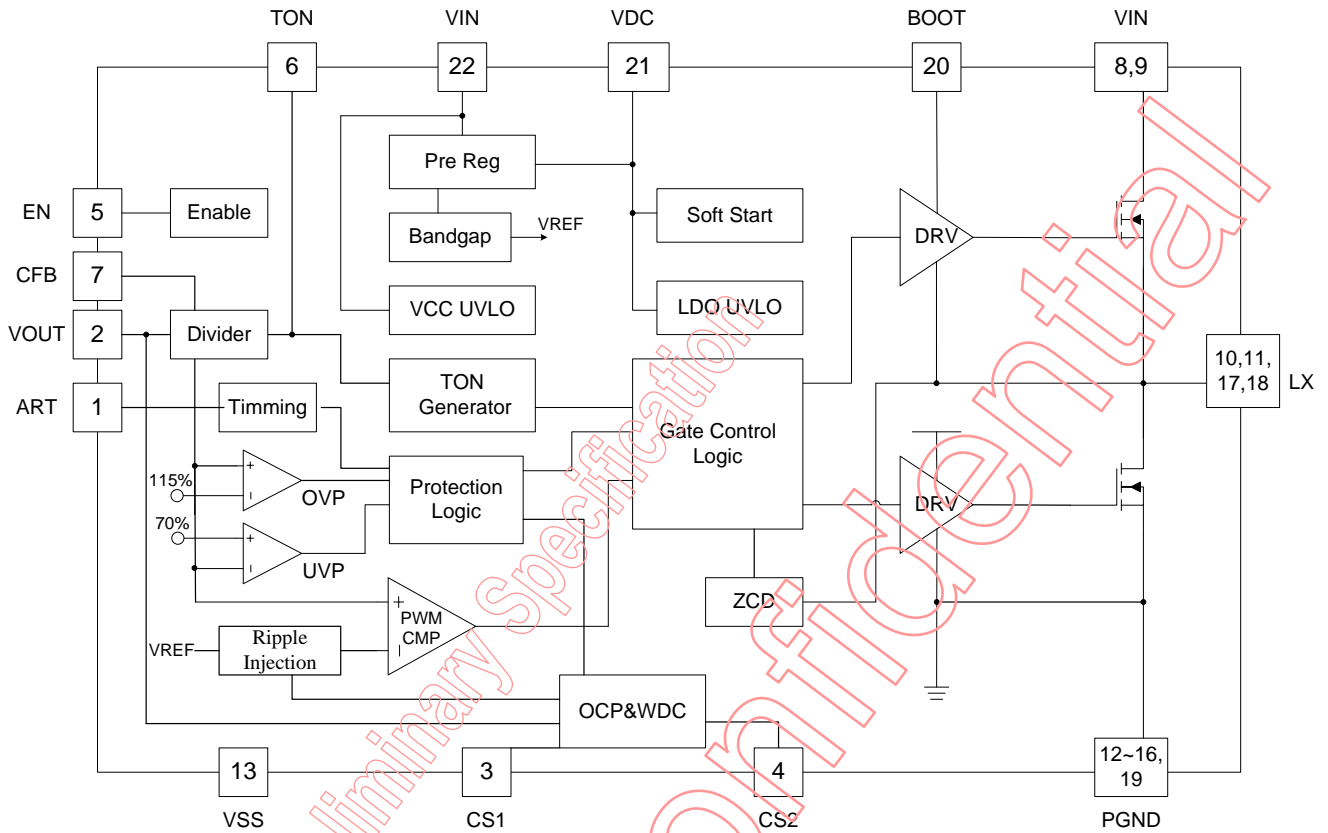
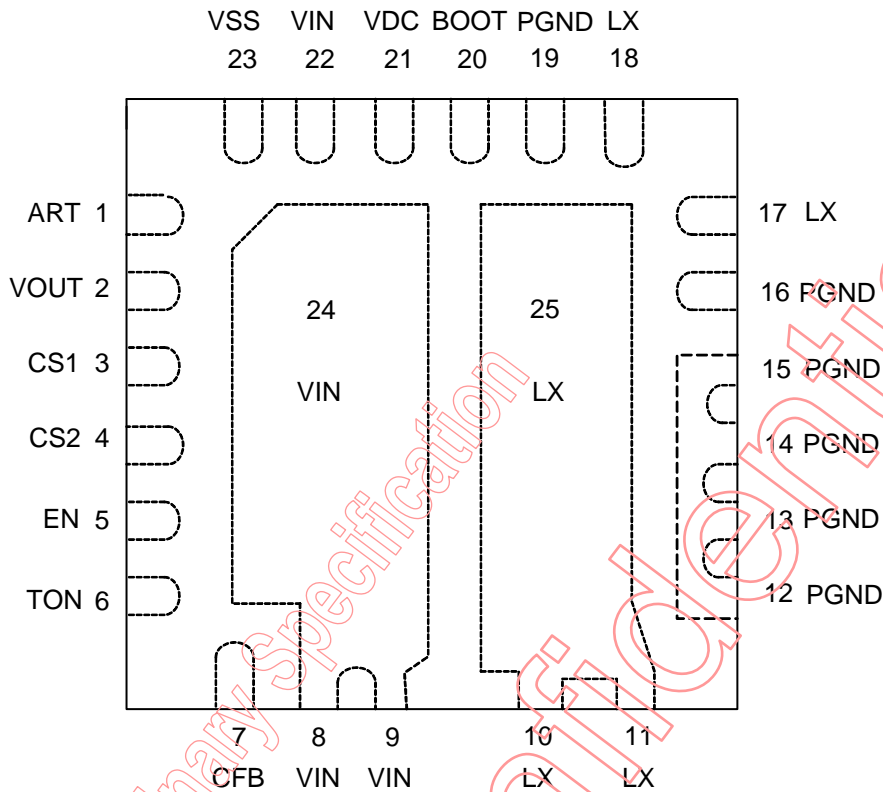

Figure 2 Function Block Diagram

Pin Configuration



(Top view)

Figure 3 QFN23-4x4 Package

Pin Descriptions

No.	Name	I/O	Description
1	ART	I	Setting auto-restart time. Connect a capacitor to VSS
2	VOUT	I/O	Output voltage feedback pin. Connect to output capacitor.
3	CS1	I	Channel 1 current sense.
4	CS2	I	Channel 2 current sense.
5	EN	I	Enable Control Pin. EN=Low, Shutdown; EN=High, Auto-DEM Mode; EN=Floating, Forced CCM.
6	TON	I	On time setting. Connect a resistor to VIN.
7	CFB	I	Feedback pin.
8,9,22,24	VIN	I	Chip power supply for Power MOSFET.
10,11,17,18,25	LX	I	Upper driver floating ground and used to sense the current of inductor.
12~16,19	PGND	I	Power ground for Power MOSFET.

20	BOOT	I/O	Power supply for high-side driver. Connect a 0.1uF capacitor between BOOT and LX.
21	VDC	I/O	Internal output regulator. Connect a capacitor to VSS
23	VSS	I/O	Ground pin for internal circuit.

Ordering Information



No	Item	Contents
1	Package	QF: QFN23-4x4
2	Shipping	R: Tape & Reel

Example: GS92D2 QFN23-4x4 Tape & Reel ordering information is "GS92D2QF-R"

Absolute Maximum Rating (Note 1)

Parameter	Symbol	Limits	Units
VIN to GND	V_{IN}	-0.3 ~ 40	V
TON to GND	V_{TON}	-0.3 ~ 40	V
CS to GND	$V_{CS1,2}$	-0.3 ~ 6	V
VDC to GND	V_{DC}	-0.3 ~ 6	V
ART to GND	V_{ART}	-0.3 ~ 6	V
EN to GND	V_{EN}	-0.3 ~ 40	V
VOOUT/VFB to GND	$V_{OUT/VFB}$	-0.3 ~ 6	V
BOOT Voltage	$V_{BOOT-GND}$	-0.3 ~ 46	V
BOOT to LX Voltage	$V_{BOOT-LX}$	-0.3 ~ 6	V
LX to GND	V_{LX}	-0.7V~40V (DC) -8V~40V(<200nS)	V
Package Power Dissipation at $T_A \leq 25^\circ\text{C}$	$P_{D_QFN23-4x4}$	3546	mW
Junction Temperature	T_J	- 45 ~ 150	°C
Storage Temperature	T_{STG}	- 55 ~ 150	°C
Lead Temperature (Soldering) 10S	T_{LEAD}	260	°C
ESD (Human Body Mode) (Note 2)	V_{ESD_HBM}	2K	V
ESD (Machine Mode) (Note 2)	V_{ESD_MM}	200	V

Thermal Information (Note 3)

Parameter	Symbol	Limits	Units
Thermal Resistance Junction to Ambient	$\theta_{JA_QFN23-4x4}$	28.2	°C/W

Recommend Operating Condition (Note 4)

Parameter	Symbol	Limits	Units
VIN to GND (Note 5)	V_{IN}	10~36	V
VDC to GND	V_{DC}	4.5~5.5	V
EN to GND	V_{EN}	$V_{EN} = V_{IN}$	V
Junction Temperature	T_J	-40 ~125	°C
Ambient Temperature	T_A	-40 ~ 85	°C

Electrical Characteristics

($R_{TON}=1\text{MEGOhm}$, $V_{IN}=12\text{V}$, $EN=\text{Floating}$, $T_A=25^\circ\text{C}$, unless otherwise specified)

Parameter	Symbol	Conditions	Min	Typ	Max	Units
Supply Voltage (VIN)						
Under voltage lock out (Rising)	V_{IN_UVLO}			9		V
UVLO Hysteresis	$V_{IN_UVLOHYS}$			0.7		V
5V Pre-regulator (VDC)						
Output Voltage	V_{DC}			5.15		V
Under voltage lock out (Rising)	V_{VDC_UVLO}			4.3		V
UVLO Hysteresis	$V_{VDC_UVLOHYS}$			0.3		V
Vout Section						
Vout Reference Voltage	V_{OUT_R}			5.1		V
Vout Operation Current	I_{OUT_OP}			70		uA
Vout Discharge Current	I_{OUT_DIS}			10		mA
EN Logic						
EN Logic Low Voltage	V_{EN_L}	EN Falling			0.6	V
EN Floating Voltage	V_{EN_F}	EN Rising		1.7		V
EN Logic High Voltage	V_{EN_H}	PFM Falling	3.1			V
EN Logic High Input Current	I_{EN_H}	PFM Rising		14		uA
EN Logic Low Input Current	I_{EN_L}		-2	-1		uA
Accurate OCP(CS1/CS2)						
OCP Threshold	V_{OCP}		100.5	108	115.5	mV
OCP Delay	T_{OCP}			5		us
CS Sinking Current	I_{CS_OFF}	EN=0			0.01	uA
	I_{CS_ON}	EN=Floating		2.2		uA
Current Parameters(VIN)						
Quiescent Current	I_Q	$V_{OUT}=5.5\text{V}, V_{IN}=12\text{V}$		760		uA
Shutdown Current	I_{OFF}	EN=0, $V_{IN}=12\text{V}$		4		uA
System Time						
On-Time	T_{ON}	$V_{IN}=12\text{V}, V_{OUT}=4.8\text{V}$		3.9		us

TON Current	I_{TON_OFF}	$V_{IN}=12V, EN=0V$			0.01	uA
	I_{TON_ON}	$V_{IN}=12V, EN=12V$		11.3		
Minimum Off-Time	T_{OFFMIN}	$V_{IN}=12V, V_{OUT}=4.8V$		450		ns
Softstart Time						
Internal Softstart Time	T_{SS}			2.6		ms
Auto Restart Section						
Auto-restart Threshold Voltage	V_{ART}			2		V
ART charging Current	I_{ART_CHG}			2		uA
ART discharging Current	I_{ART_DIS}	$V_{ART}=1.8V$		1.5		mA
Driver Section						
High Side MOS RDSON	R_{DSH}	BOOT-LX=5V		25		mohms
High Side Leakage	I_{LEAKH}			10		uA
Low Side MOS RDSON	R_{DSL}	VDC-GND=5V		11		mohms
Low Side Leakage	I_{LEAKL}			10		uA
LX Current Sensing						
Current Limit	I_{LIM}	GND-LX ; $F_{SW}=100K, L=10uH$		6.3		A
Zero Crossing Threshold	V_{ZCD}	GND-LX		-10	10	mV
Voltage Fault Protection						
UV Threshold	V_{UV_TH}			70		%
UV Fault Delay	T_{UV_D}			20		us
OVP Threshold	V_{OV_TH}			115		%
OVP Delay	T_{OV_D}			20		us
Over Temperature Shutdown						
Thermal Shutdown Threshold	T_{TSDN}			150		°C
Thermal Shutdown Hysteresis	T_{HYS_TSDN}			20		°C
Bootstrap Diode						
Internal Boost Charging Switch On-Resistance	R_{BT_D}	VIN to BOOT, 10mA		80		ohms

Wire Drop Compensation						
Wire Drop Compensation Rate	R_{WDC}	$V_{ART}=1V$ ($V_{OUT}-V_{CS}=100mV$)		120		mv
Short Protection When Start Up						
Short Protection Delay Time	T_{SP}	$V_{OUT}=0.4V$		1		ms

Note 1. Stresses listed as the above “Absolute Maximum Ratings” may cause permanent damage to the device. These are for stress ratings. Functional operation of the device at these or any other conditions beyond those indicated in the operational sections of the specifications is not implied. Exposure to absolute maximum rating conditions for extended periods may remain possibility to affect device reliability.

Note 2. Devices are ESD sensitive. Handling precaution recommended.

Note 3. θ_{JA} is measured in the natural convection at $T_A=25^\circ C$ on a high effective thermal conductivity test board (4 Layers, 2S2P) of JEDEC 51-7 thermal measurement standard.

Note 4. The device is not guaranteed to function outside its operating conditions.

Note 5. Recommend the Pulse time < 100ns when V_{IN} over than 40V.

Note 6. If $V(BOOT)-V(LX)<4V$, a boot diode is recommended.

Application Information

The GS92D2 is a synchronous Buck Converter with COT control scheme. Features include wide input voltage range, dual channel accurate OCP, wire drop compensation and programmable timing of auto-restart after protections.

System Clock Generator and PWM Control

The on-time of GS92D2 can be set by an external setting resistor from VIN to TON, thus the GS92D2 based Buck converter has a relative constant operation frequency over wide input voltage range.

At the beginning of each switching cycle, upper power MOSFET is turned on, after typical fixed on-time, the upper MOSFET is turned off, and then lower power MOSFET is turned on after internal dead time. The upper MOSFET will not be turned on at the beginning of next cycle until output voltage falls down below the preset voltage.

To avoid the surge inductor current during large load transient, a minimum Off-time is added. Typical minimum off-time is around 450ns.

High Side Switch On-Time Count

The on-time is decided by the external setting resistor, and the input voltage. Looking at the TON pin, the input voltage is converted to current which is inversely proportional to itself by dividing the external setting resistor. The TON current is used to charge an internal capacitor and when the voltage of the capacitor reaches the internal voltage which is proportional to output voltage, on-time one-shot pulse is generated, and then upper power MOSFET is turned off and lower power MOSFET is turned on.

We can count the on-time and switching frequency according to the equations below:

$$T_{ON} = (V_{OUT} \times R_{TON} \times 8.93p) / (V_{IN} - 0.8)$$

Then, the switching frequency is:

$$F_{sw} = V_{OUT} / (V_{IN} \times T_{ON})$$

R_{TON} is a resistor connected from input voltage (VIN)

to TON pin.

For heavy load application, due to ground bounced and the high impedance of R_{TON} , the TON pin should always be bypassed to AGND using a several nF-order ceramic capacitor for reliable system operation.

EN Control and Mode Selection

The EN pin enables the power supply. When EN is tied to VIN, the GS92D2 is enabled and operated in diode-emulated mode (DEM, which is power-saving). When EN is floating, the GS92D2 is also enabled but operated in CCM.

In DEM mode, when the load turns light, the GS92D2 maintains the on-time and extend the off-time, which decrease the system clock frequency to skip PWM pulses for better efficiency. When DEM is enabled, the GS92D2 zero crossing detector will sense the inductor current from LX pin and judge its value by comparing the LX pin voltage to ground. Once the LX node voltage is equal to the PGND node voltage, the converter will turn off the low side power MOSFET and enter DEM. As the load current decrease, it takes longer time to discharge the output capacitor to the level that required to start the next switching cycle. The on-time is kept the same as in the heavy-load operation.

If the EN pin is pulled low, the GS92D2 will be shut down and discharge the output capacitor through the VOUT pin. Since this is a soft discharge, there is no dangerous negative voltage excursion to be concerned about. In order to maintain the correct function of the soft-discharge module, the chip power supply must be online.

Accurate Over Current Protection

The accurate OCP is implemented by the CS1 and CS2 pins. OCP is triggered and shuts down UG and LG if $(V_{OUT} - V_{CS1})$ or $(V_{OUT} - V_{CS2})$ is higher than 108mV (Typical), thus the OCP threshold can be set by the following equation:

$$I_{OCP}=108\text{mv}/R_S$$

R_S is the sense resistor connected between VOUT pin and CS pin. The OCP has 5us de-bounce time.

When OCP is triggered, the GS92D2 will enter a auto-restart procedure: delay a time period and rebuild the output from soft start. The delay time can be set by ART pin.

Auto-restart Setting

The GS92D2 will auto-restart when protections occurred. Before restart, a delay time period can be set by connecting a capacitor from ART pin to VSS pin. A current will charge the capacitor from ground level to a preset level. The delay time is calculated by the following equation:

$$T_{ART}=1E6*C_{ART}$$

Wire Drop Compensation

The GS92D2 will compensate the cable voltage drop due to the output current. The output current is sensed by CS1 pin and CS2 pin as mentioned before. The GS92D2 will choose the larger output current to compensate if the current of two channels are different.

Current Limit

The GS92D2 uses the on-state resistance of the low-side power MOSFET as a current-sense resistor to sense the inductor current. In this case, the GS92D2 build in a cycle-by-cycle current limit. The current limit circuit regulates the inductor valley current that means if the valley value of the inductor current exceeded a preset level the PWM is not allowed to initiate a new switching cycle.

During soft-start, the GS92D2 will linearly release the current limit according to the internal soft-start ramp. The current limit will be fully released about 1ms after soft start begun.

Output Over-Voltage Protection

When the VOUT voltage rises up to 115% of the normal operating voltage, the internal fault-logic

module delays about 20us and turns on the low-side Power MOSFET. The state is maintained until the ART timing is over, and the GS92D2 will restart.

Output Under-Voltage Protection

When the VOUT voltage falls down to 70% of the normal operating voltage, the internal fault-logic module will delay about 20us and turns on the low-side Power MOSFETs. The state is maintained until the ART timing is over, and the GS92D2 will restart. UVP is disabled during soft start.

VDC and VIN UVLO

An internal under voltage lockout (UVLO) module is used to sense the VDC power supply. The PWM converter is forbidden by the under voltage lockout module. When VDC rises above 4.3V, the GS92D2 will initial the control logic circuitries and soft-start ramping generator, and then allows switching to occur. When VDC falls below 4.0V, the PWM converter is forbidden. When VIN rises above 9V, the LDO output voltage (VDC) of GS92D2 enables and regulates a 5.15V voltage. After VIN falls below 8.3V the LDO (VDC) will turn off.

Short Circuit Protection

During soft start, if short circuit occurs, the output current will increase rapidly to current limit and the state maintained until soft start finished, which makes the external components endure a big stress. The GS92D2 offers rapid protections when short circuit occurred during soft start.

VOUT Pin

The VOUT pin offers feedback information of output voltage, which makes the ton more accurate, so the switching frequency variation is very small even when the GS92D2 operates in a very wide input voltage range. When any fault condition occurs, the VOUT pin provides a discharge path from output to ground.

Choose Inductor

Set the ripple current approximately 1/4 to 1/2 of the

maximum output current. 1/3 is recommended.

$$L_{IND} = \frac{1}{I_{IND(ripple)} \times f} \times \frac{(V_{IN(max)} - V_{OUT}) \times V_{OUT}}{V_{IN(max)}}$$

$$L_{IND} = \frac{3}{I_{IOUT(max)} \times f} \times \frac{(V_{IN(max)} - V_{OUT}) \times V_{OUT}}{V_{IN(max)}}$$

For applications that require fast transient response with minimum VOUT overshoot, consider a smaller inductance than above. The cost of a small inductance value is higher steady state ripple, larger line regulation, and higher switching loss.

The inductor also needs to have low DCR to achieve good efficiency, as well as enough room above peak inductor current before saturation. The peak inductor current can be estimate as follows.

$$L_{IND(peak)} = \frac{1}{L \times f} \times \frac{(V_{IN(max)} - V_{OUT}) \times V_{OUT}}{V_{IN(max)}} + \frac{V_{CL}}{R_{DS(on)}}$$

Choose Output Capacitors

$$RESR = \frac{1}{I_{ripple}} \times 0.038$$

$$\approx \frac{3}{I_{OUT(max)}} \times 0.038$$

$$RESR \approx \frac{V_{OUT}}{I_{OUT(max)}} \times 114(mohm)$$

Organic semiconductor capacitors or specialty polymer capacitors are recommended.

Package Dimensions, QFN23-4x4

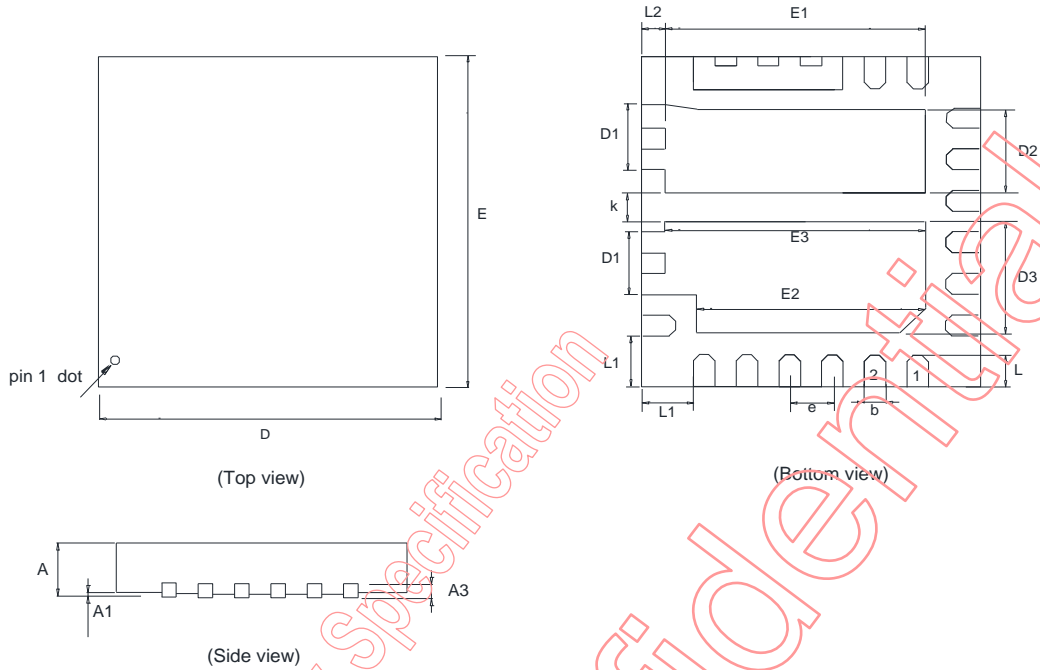

Symbol	Dimensions in Millimeters	
	Min.	Max.
A	0.80	0.90
A1	0.00	0.05
A3	0.203 REF.	
b	0.20	0.30
D	3.90	4.10
D1	0.65	0.85
D2	0.85	1.05
D3	1.24	1.44
E	3.90	4.10
E1	2.95	3.15
E2	2.60	2.70
E3	2.95	3.15
L	0.35	0.45
L1	0.57	0.67
L2	0.23	0.33
e	0.50 REF.	
k	0.33	-

Note

1. Min.: Minimum dimension specified.
2. Max.: Maximum dimension specified.
3. REF.: Reference. Normal/Regular dimension specified for reference.

DISCLAIMERS

Please read the notice stated in this preamble carefully before Admission e accessing any contents of the document attached. Admission of GStek's statement therein is presumed once the document is released to the receiver.

Notice:

Firstly, GREEN SOLUTION CO., LTD. (GStek) reserves the right to make corrections, modifications, enhancements, improvements, and other changes to its information herein without notice. And the aforesaid information does not form any part or parts of any quotation or contract between GStek and the information receiver.

Further, no responsibility is assumed for the usage of the aforesaid information. GStek makes no representation that the interconnect of its circuits as described herein will not infringe on exiting or future patent rights and other intellectual property rights, nor do the descriptions contained herein express or imply that any licenses under any GStek patent right, copyright, mask work right, or other GStek intellectual property right relating to any combination, machine, or process in which GStek products or services are used.

Besides, the product in this document is not designed for use in life support appliances, devices, or systems where malfunction of this product can reasonably be expected to result in personal injury. GStek customers' using or selling this product for use in such applications shall do so at their own risk and agree to fully indemnify GStek for any damage resulting from such improper use or sale.

At last, the information furnished in this document is the property of GStek and shall be treated as highly confidentiality; any kind of distribution, disclosure, copying, transformation or use of whole or parts of this document without duly authorization from GStek by prior written consent is strictly prohibited. The receiver shall fully compensate GStek without any reservation for any losses thereof due to its violation of GStek's confidential request. The receiver is deemed to agree on GStek's confidential request therein suppose that said receiver receives this document without making any expressly opposition. In the condition that aforesaid opposition is made, the receiver shall return this document to GStek immediately without any delay.