

GSCLM317L

100mA ADJUSTABLE VOLTAGE REGULATOR

Description

The GSCLM317L is a monolithic integral circuit, designed for use as positive adjustable voltage regulator. It is designed to supply unit 100mA of load current with an output voltage adjustable over a 1.25V to 37V range.

Features

- Output voltage adjustable from 1.25V to 37V
- Output current in excess of 100mA
- Thermal overload protection
- Short circuit protection
- Output transistor save area compensation
- Floating operation for high voltage applications

Package Dimensions

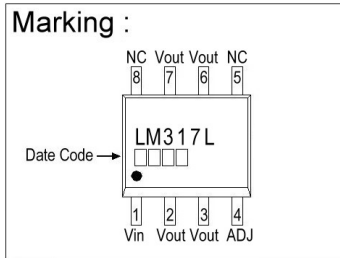
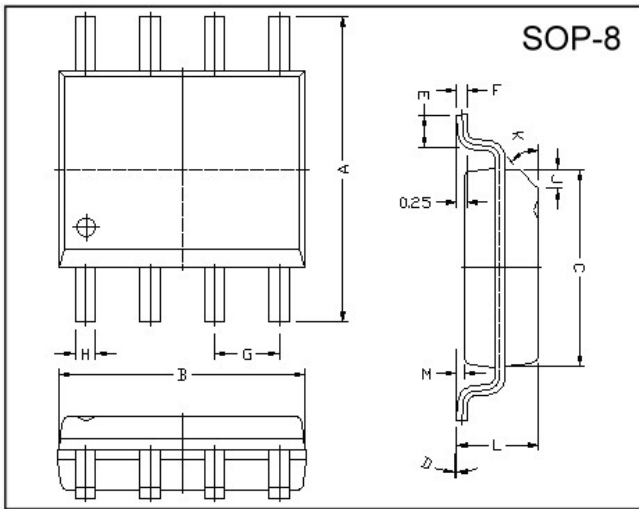

REF.	Millimeter		REF.	Millimeter	
	Min.	Max.		Min.	Max.
A	5.80	6.20	M	0.10	0.25
B	4.80	5.00	H	0.35	0.49
C	3.80	4.00	L	1.35	1.75
D	0°	8°	J	0.375 REF.	
E	0.40	0.90	K	45°	
F	0.19	0.25	G	1.27 TYP.	

Block Diagram

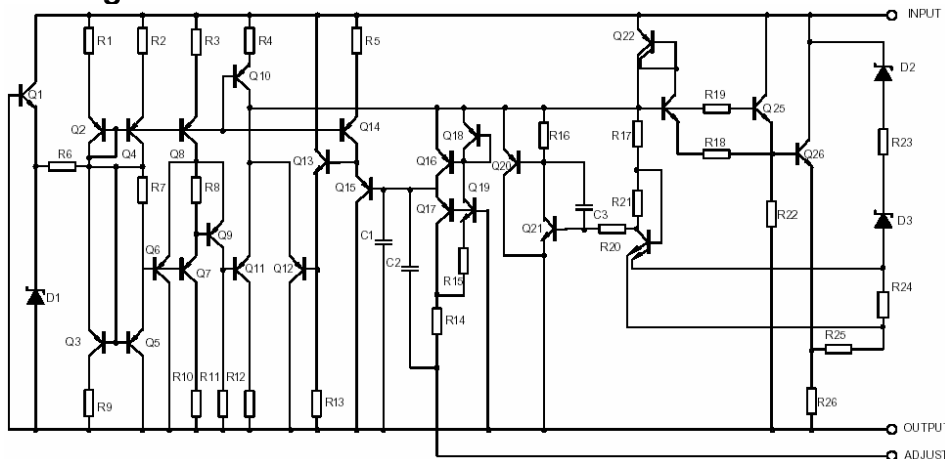

Test Circuit

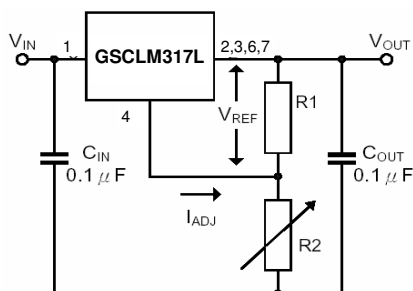

Absolute Maximum Ratings at Ta = 25°C

Parameter	Symbol	Ratings	Unit
Input-Output Voltage Difference	$V_{IN} - V_{OUT}$	40	V
Power Dissipation	P_D	625	mW
Junction Temperature	T_J	+125	°C
Operating Junction Temperature	T_{OPR}	0 ~ +70	°C
Storage Temperature Range	T_{STR}	-40 ~ +150	°C

Note 1. Absolute maximum ratings are those values beyond which the device could be permanently damaged. Absolute maximum ratings are stress ratings only and functional device operation is not implied.

Note 2. The device is guaranteed to meet performance specification within 0°C ~ 70°C operating temperature range and assured by design from -20°C ~ 85°C.

Electrical Characteristics

($V_{IN} - V_{OUT}=5V$, $0^\circ C \leq T_J \leq 125^\circ C$, $I_O=40mA$, unless otherwise specified)

Parameter	Symbol	Test Conditions	Min	TYP	Max	Unit	
Line Regulation	REGLINE	$V_{IN} - V_{OUT}=3\sim 40V$ $I_O < 20mA$	$T_J=25^\circ C$	-	0.01	0.04	%/V
			$0^\circ C \leq T_J \leq 125^\circ C$	-	0.02	0.07	%/V
Load Regulation	REGLOAD	$I_O=5\sim 100mA$ $V_{OUT} \leq 5V$	$T_J=25^\circ C$	-	5	25	mV
			$0^\circ C \leq T_J \leq 125^\circ C$	-	20	70	mV
		$I_O=5\sim 100mA$ $V_{OUT} \geq 5V$	$T_J=25^\circ C$	-	0.1	0.5	%/V _{OUT}
			$0^\circ C \leq T_J \leq 125^\circ C$	-	0.3	1.5	
Adjustable Pin Current	I_{ADJ}		-	50	100	μA	
Adjustable Pin Current Change	ΔI_{ADJ}	$V_{IN} - V_{OUT}=3\sim 40V$ $I_O=5\sim 100mA$, $P_D < 625mW$	-	0.2	5	μA	
Reference Voltage	V_{REF}	$V_{IN} - V_{OUT}=3\sim 40V$ $I_O=5\sim 100mA$, $P_D < 625mW$	1.2	1.25	1.3	V	
Output Voltage Temperature Stability	$\Delta V_{OUT}/V_{OUT}$		-	0.7	-	%	
Minimum Load Current	$I_{LOAD(Min)}$	$V_{IN} - V_{OUT}=40V$	-	3.5	5	mA	
Maximum Output Current	$I_{OUT(Max)}$	$V_{IN} - V_{OUT}=3\sim 13V$	100	200	-	mA	
		$V_{IN} - V_{OUT}=40V$	25	50	-		
Output Noise Voltage (% of V _{OUT})	eN	$f=10Hz \sim 10KHz$, $T_J=25^\circ C$	-	0.003	-	%/V _{OUT}	
Ripple Rejection	RR	$T_J=25^\circ C$, $f=120Hz$	$C_{ADJ}=0$	-	65	-	dB
			$C_{ADJ}=10\mu F$	66	80	-	

Note: C_{ADJ} is connected between Adjust pin and Ground.

Characteristics Curve

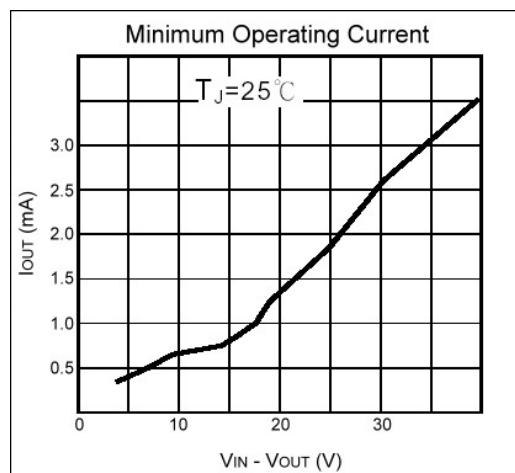
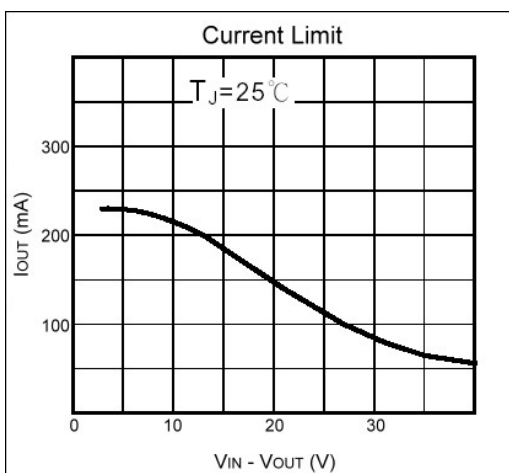

Application Information and Circuits

The GSCLM317L provides an internal reference voltage of 1.25V between the output and adjustments terminals. This is used to set a constant current flow across an external resistor driver, giving an output voltage V_{OUT} of:

$$V_{OUT} = V_{REF} * (1 + R2 / R1) + I_{ADJ} * R2$$

The device is designed to minimize the term I_{ADJ} (100uA max) and to maintain it very constant with line and load changes. Usually, the error term $I_{ADJ} * R2$ can be neglected. To obtain the previous requirement, all the regulator quiescent current is returned to the output terminal, imposing a minimum load current condition. If the load is insufficient, the output voltage will rise. The GSCLM317L is a floating regulator, input-output differential voltage, supplies of very high voltage with respect to ground can be regulated as long as the maximum input-output differential is not exceeded. Furthermore, programmable regulators are easily obtainable and, by connecting a fixed resistor between the adjustment and output, the device can be used as a precision current regulator.

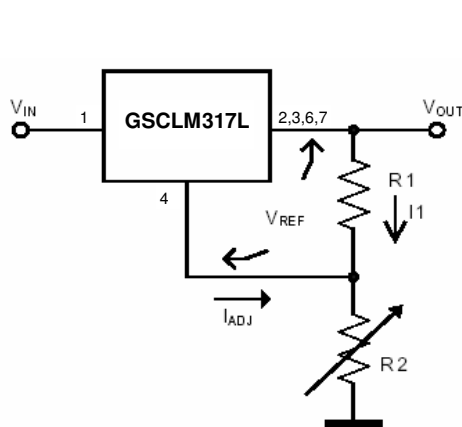

Fig 1. Basic Adjustable Regulator

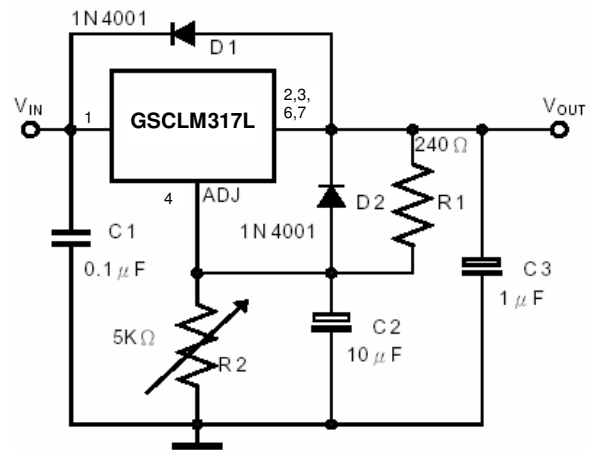

Fig 2. Voltage Regulator with Protection Diodes

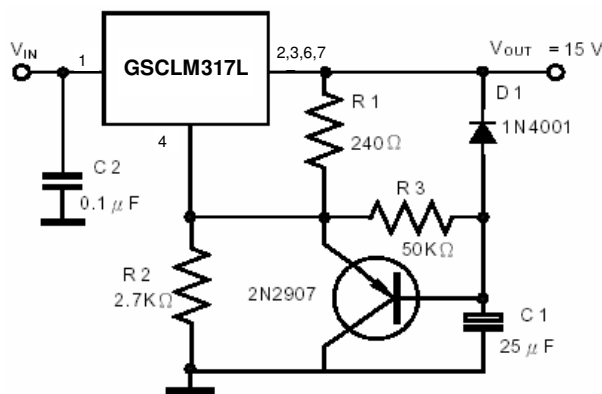

Fig 3. Slow Turn-On 15V Regulator

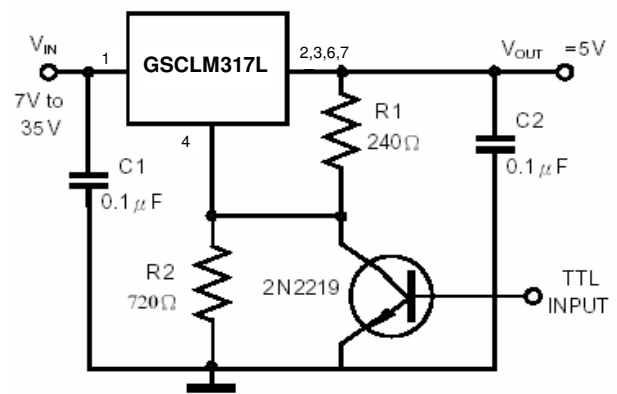

Fig 4. 5V Electronic Shut-Down Regulator

Important Notice:

- All rights are reserved. Reproduction in whole or in part is prohibited without the prior written approval of GTM.
- GTM reserves the right to make changes to its products without notice.
- GTM semiconductor products are not warranted to be suitable for use in life-support Applications, or systems.
- GTM assumes no liability for any consequence of customer product design, infringement of patents, or application assistance.

Head Office And Factory:

- **Taiwan:** No. 17-1 Tatung Rd. Fu Kou Hsin-Chu Industrial Park, Hsin-Chu, Taiwan, R. O. C.
- **TEL :** 886-3-597-7061 **FAX :** 886-3-597-9220, 597-0785
- **China:** (201203) No.255, Jang-Jiang Tsai-Lueng RD. , Pu-Dung-Hsin District, Shang-Hai City, China
- **TEL :** 86-21-5895-7671 ~ 4 **FAX :** 86-21-38950165