

GSCLP2951

100mA Low-Dropout Voltage Regulator

Description

The GSCLP2951 is a low power voltage regulator. This device excellent choice for use in battery powered application such as cordless telephone, radio control systems, and portable computers. The device features very low quiescent current (75uA Typ.) and very low drop output voltage (Typ. 40mV at light load and 380mV at 100mA). This includes a tight initial tolerance of 0.5% typ., extremely good load and line regulation of 0.05% typ., and very low output temperature coefficient, marking the part useful as a low-power voltage reference. The error flag output feature is used as power-on reset for warns of a low output voltage, due to following batteries on input. Other feature is the logic-compatible shutdown input which enable the regulator to be switched on and off. The regulator output voltage may be pin-strapped for fixed output voltage or programmed from 1.24V to 29V with external pair of resistors.

Features

- High accuracy output voltage
- Extremely low quiescent current and dropout voltage
- Extremely tight load and line regulation
- Current and thermal Limiting
- Very low temperature coefficient
- Error flag warns of output dropout
- Logic-Controlled electronic shutdown

Applications

- Battery powered equipment
- Cellular Phones
- Portable/Palm top/Notebook computers

Package Dimensions

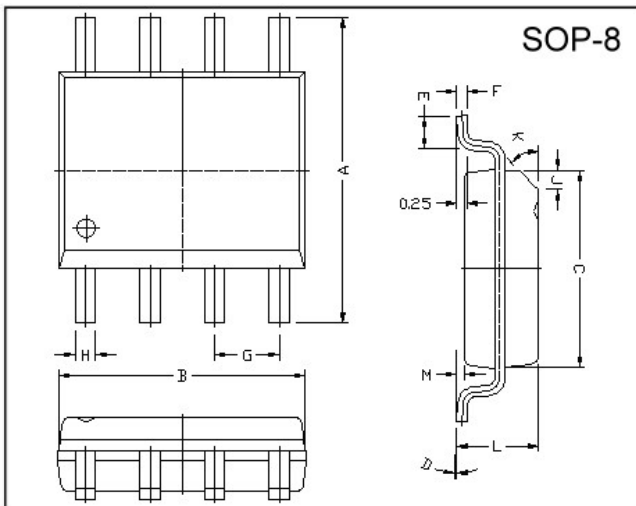

Marking :

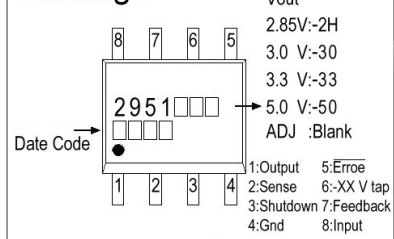

REF.	Millimeter		REF.	Millimeter	
	Min.	Max.		Min.	Max.
A	5.80	6.20	M	0.10	0.25
B	4.80	5.00	H	0.35	0.49
C	3.80	4.00	L	1.35	1.75
D	0°	8°	J	0.375 REF.	
E	0.40	0.90	K	45°	
F	0.19	0.25	G	1.27 TYP.	

Block Diagram and Typical Applications

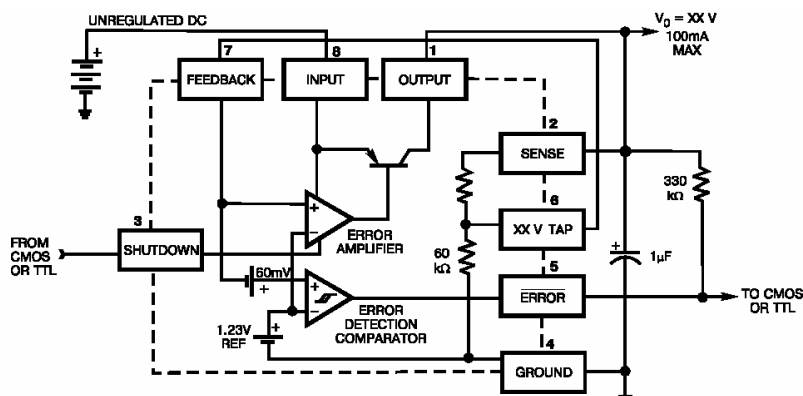

Absolute Maximum Ratings

Parameter	Symbol	Ratings	Unit
Input Voltage	V _{CC}	-0.3 ~ +30	V
Output Current	I _{OUT}	100	mA
Feedback Input Voltage	V _{FB}	-1.5 ~ +30	V
Shutdown Input Voltage	V _{SD}	-0.3 ~ +30	V
Error Comparator Output	V _{CO}	-0.3 ~ +30	V
Storage Temperature	T _{stg}	-65 ~ +150	°C
Maximum Junction Temperature	T _{jmax}	150	°C
Operating Junction Temperature	T _j	-55 ~ +150	°C

Electrical Characteristics (T_a=25°C, V_{IN}=15V, unless otherwise specified) (Note2)

Parameter	Condition	Min	TYP	Max	Unit
Output Voltage	GLP2950-2H	2.793	2.85	2.907	V
	GLP2950-30	2.940	3.00	3.060	
	GLP2950-33	3.234	3.30	3.366	
	GLP2950-50	4.900	5.00	5.100	
Line Regulation (Note3)	V _O +1≤V _{IN} ≤30V (Note4)	-	0.04	0.4	%
Load Regulation (Note3)	100μA≤I _O ≤100mA	-	0.1	0.3	%
Current Limit	V _{OUT} =0	-	160	200	mA
Output Voltage Temperature Coefficient	(Note1)	-	50	150	ppm/°C
Dropout Voltage (Note5)	I _O =100μA	-	50	80	mV
	I _O =100mA	-	380	450	
Ground Current	I _O =100μA	-	75	120	μA
	I _O =100mA	-	8	12	mA
Dropout Ground Current	V _{IN} =V _O -0.5V, I _O =100μA	-	110	170	μA
Thermal Regulator		-	0.05	0.2	%/W
Output Voltage Noise f=10Hz~100kHz	C _L =1μF	-	430	-	μVrms
	C _L =200μF	-	160	-	
	C _L =3.3μF (Bypass=0.01μF pins 7 to 1)	-	100	-	
Reference Voltage		1.210	1.235	1.260	V
Reference Voltage	Over Temperature(Note6)	1.185		1.285	V
Feedback pin Bias Current		-	20	40	nA
Reference Voltage Temperature Coefficient	(Note1)	-	50	-	ppm/°C
Feedback pin Bias Current Temperature Coefficient		-	0.1	-	nA/°C
Error Comparator					
Output Leakage Current	V _{OH} =30V	-	0.01	1.0	μA
Output Low Voltage	V _{IN} =4.5V, I _{OL} =400μA	-	150	250	mV
Upper Threshold Voltage	(Note7)	40	60	-	mV
Low Threshold Voltage	(Note7)	-	75	95	mV
Hysteresis	(Note7)	-	15	-	mV
Shutdown Input					
Input Logic Voltage	Low (Regulator ON)	-	1.3	0.7	V
	High (Regulator OFF)	2	-	-	
Shutdown pin Input Current	V _S =2.4V	-	30	50	μA
	V _S =30V	-	450	600	
Regulator Output Current in Shutdown (Note8)	V _{OUT} =5.0V	-	3	10	μA
	3.3V≤V _{OUT} <5.0V	-	-	20	
	2.0V≤V _{OUT} <3.30V	-	-	30	

Note 1: Output or reference voltage temperature coefficient is defined as the worst case voltage change divided by the total temperature range.

Note 2: Unless otherwise specified all limits guaranteed for $T_j=25^{\circ}\text{C}$, $V_{in}=V_o+1\text{V}$, $I_L=100\mu\text{A}$ and $C_L=1\mu\text{F}$. Additional conditions are feedback tied to GSCLP2951-XX tap and output tied to Sense ($V_{out}=XX\text{V}$) and $V_{shutdown}\leq 0.8\text{V}$.

Note 3: Regulations is measured at constant junction temperature, using pulse testing with a low duty cycle. Changes in output voltage due to heating effects are covered under the specification for thermal regulation.

Note 4: Line regulation for GSCLP2951-XX is tested at 150°C for $I_L=1\text{mA}$. For $I_L=100\mu\text{A}$ and $T_j=125^{\circ}\text{C}$, line regulation is guaranteed by design to 0.2%. See typical performance characteristics for line regulation versus temperature and load current.

Note 5: Dropout voltage is defined as the input to output differential at which the output voltage drops 100mV below its nominal value measured at 1V differential. At very low values of programmed output voltage, the minimum input supply voltage of 2V (2.3V over temperature) must be taken into account.

Note 6: $V_{ref}\leq V_{out}\leq (V_{in}-1\text{V})$, $2.3\text{V}\leq V_{in}\leq 30\text{V}$, $100\mu\text{A}\leq I_L\leq 100\text{mA}$, $T_j\leq T_{jmax}$.

Note 7: Comparator thresholds are expressed in terms of a voltage differential at the feedback terminal below the nominal reference voltage measured at $V_o+1\text{V}$ input. To express these thresholds in terms of output voltage change, multiply by the error amplifier gain $= V_{out}/V_{ref} = (R1+R2)/R2$. For example, at a programmed output voltage of 5V, the error output is guaranteed to go low when the output drops by $95\text{mV} \times 5\text{V}/1.235\text{V}=384\text{mV}$. Thresholds remain constant as a percent of V_{out} as V_{out} is varied, with the dropout warning occurring at typical 5% below nominal, 7.5% guaranteed.

Note 8: $V_{shutdown}\geq 2\text{V}$, $V_{in}\leq 30\text{V}$, $V_{out}=0$, Feed-back pin tied to -XX V Tap.

Characteristics Curve

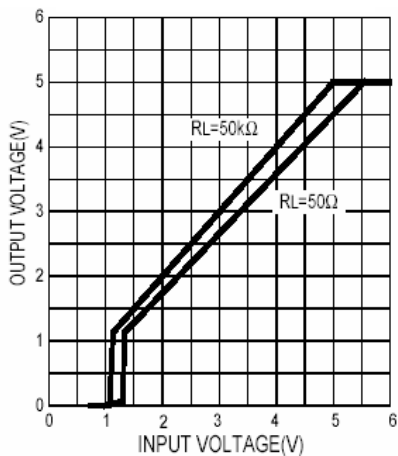

Fig 1. Dropout Characteristics

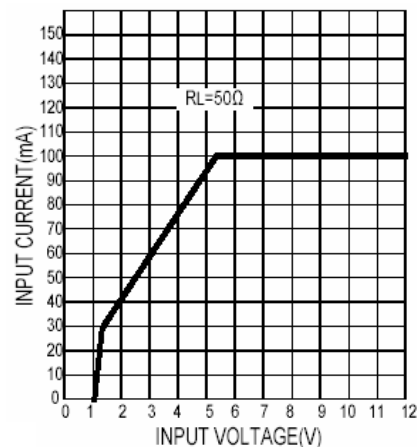

Fig 2. Input Current

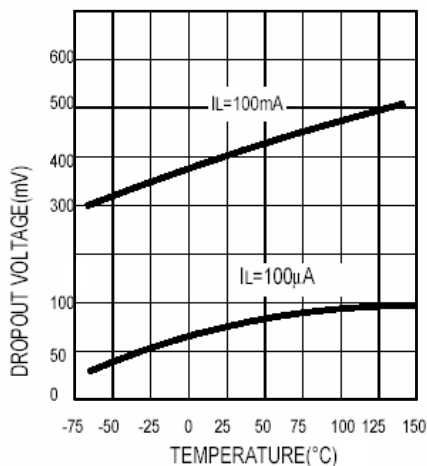

Fig 3. Dropout Voltage

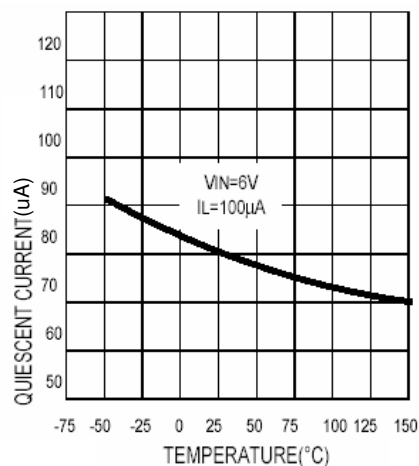

Fig 4. Ground Pin Current

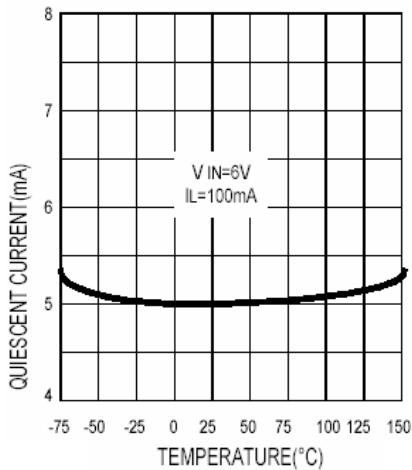

Fig 5. Ground Pin Current

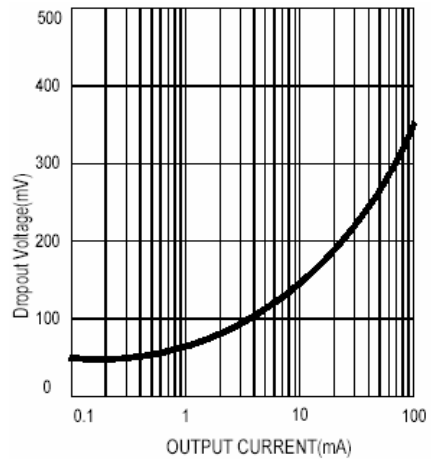

Fig 6. Dropout Voltage

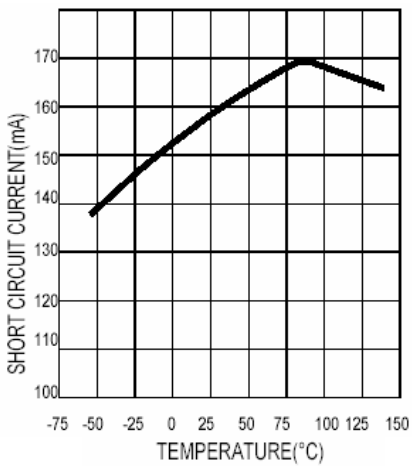

Fig 7. Short Circuit Current

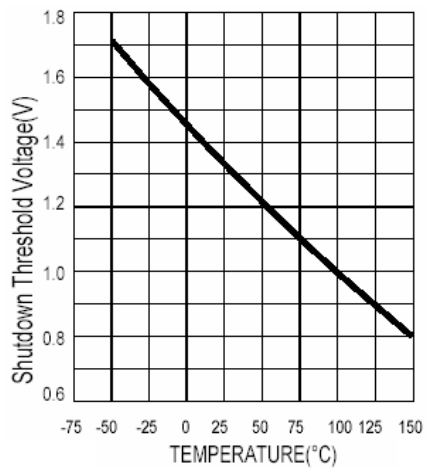

Fig 8. Shutdown Threshold Voltage

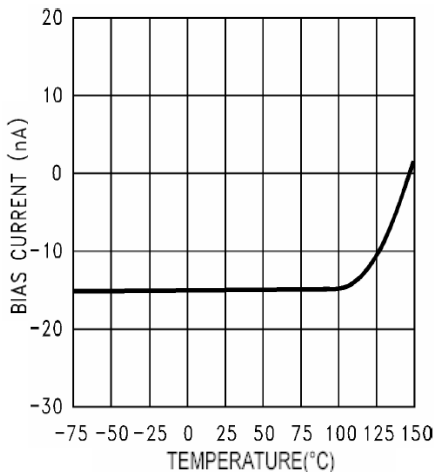

Fig 9. Feedback Bias Current

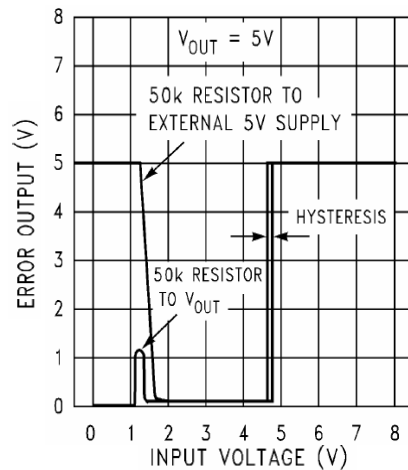

Fig 10. Error Comparator Output

Important Notice:

- All rights are reserved. Reproduction in whole or in part is prohibited without the prior written approval of GTM.
- GTM reserves the right to make changes to its products without notice.
- GTM semiconductor products are not warranted to be suitable for use in life-support Applications, or systems.
- GTM assumes no liability for any consequence of customer product design, infringement of patents, or application assistance.

Head Office And Factory:

- **Taiwan:** No. 17-1 Tatung Rd. Fu Kou Hsin-Chu Industrial Park, Hsin-Chu, Taiwan, R. O. C.
- TEL : 886-3-597-7061 FAX : 886-3-597-9220, 597-0785
- **China:** (201203) No.255, Jang-Jiang Tsai-Lueng RD. , Pu-Dung-Hsin District, Shang-Hai City, China
- TEL : 86-21-5895-7671 ~ 4 FAX : 86-21-38950165