

# GSM0910P

## 100V N-Channel MOSFETs

### Product Description

These N-Channel enhancement mode power field effect transistors are using trench DMOS technology. This advanced technology has been especially tailored to minimize on-state resistance, provide superior switching performance, and withstand high energy pulse in the avalanche and commutation mode.

These devices are well suited for high efficiency fast switching applications.

### Features

- 100V, 2A,  $R_{DS(ON)}=200m\Omega@V_{GS}=10V$
- Improved dv/dt capability
- Fast switching
- 100% EAS Guaranteed
- Green Device Available
- SOT-23 package design

### Applications

- Notebook
- Load Switch
- LED applications

### Packages & Pin Assignments

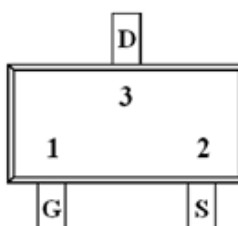
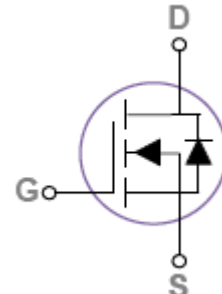
GSM0910PJZF (SOT-23)	
 <p>Top Views</p>	
	
Pin	Description
1	Gate
2	Source
3	Drain

### Ordering Information

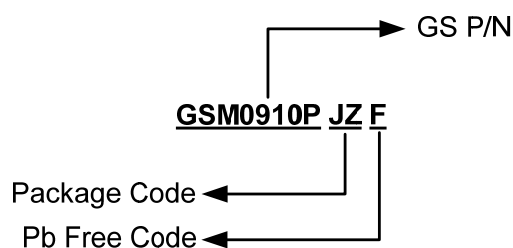

## Marking Information

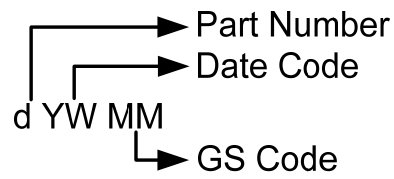

Part Number	Package	Part Marking	Quantity
GSM0910PJZF	SOT-23	dYWMM	3000pcs

## Absolute Maximum Ratings

$T_A=25^\circ\text{C}$  Unless otherwise noted

Symbol	Parameter	Typical	Unit
$V_{DS}$	Drain-Source Voltage	100	V
$V_{GS}$	Gate-Source Voltage	$\pm 20$	V
$I_D$	Continuous Drain Current	$T_A=25^\circ\text{C}$	2
		$T_A=100^\circ\text{C}$	1.3
$I_{DM}$	Pulsed Drain Current	8	A
$P_D$	Power Dissipation ( $T_A=25^\circ\text{C}$ )	1.56	W
	Power Dissipation (Derate above $25^\circ\text{C}$ )	0.012	$\text{W}/^\circ\text{C}$
$T_J$	Operating Junction Temperature Range	-50 to +150	$^\circ\text{C}$
$T_{STG}$	Storage Temperature Range	-50 to +150	$^\circ\text{C}$
$R_{\theta JA}$	Thermal Resistance-Junction to Ambient	80	$^\circ\text{C}/\text{W}$

## Electrical Characteristics

T<sub>A</sub>=25°C Unless otherwise noted

Symbol	Parameter	Conditions	Min	Typ	Max	Unit
<b>Static</b>						
V <sub>(BR)DSS</sub>	Drain-Source Breakdown Voltage	V <sub>GS</sub> =0V, I <sub>D</sub> =250uA	100			V
ΔBV <sub>DSS</sub> /ΔT <sub>J</sub>	BV <sub>DSS</sub> Temperature Coefficient	Reference to 25°C, I <sub>D</sub> =1mA		0.10		V/°C
V <sub>GS(th)</sub>	Gate Threshold Voltage	V <sub>DS</sub> =V <sub>GS</sub> , I <sub>D</sub> =250uA	1.2	1.8	2.5	V
ΔV <sub>GS(th)</sub>	V <sub>GS(th)</sub> Temperature Coefficient			-4		mV/°C
I <sub>GSS</sub>	Gate Leakage Current	V <sub>DS</sub> =0V, V <sub>GS</sub> =±20V			±100	nA
I <sub>DSS</sub>	Zero Gate Voltage Drain Current	V <sub>DS</sub> =100V, V <sub>GS</sub> =0V			1	uA
		V <sub>DS</sub> =80V, V <sub>GS</sub> =0V, T <sub>J</sub> =125°C			10	
I <sub>S</sub>	Continuous Source Current	V <sub>G</sub> =V <sub>D</sub> =0V, Force Current			2	A
I <sub>SM</sub>	Pulsed Source Current				8	
R <sub>DS(on)</sub>	Drain-Source On-Resistance	V <sub>GS</sub> =10V, I <sub>D</sub> =2A		161	200	mΩ
		V <sub>GS</sub> =4.5V, I <sub>D</sub> =1A		169	210	
g <sub>FS</sub>	Forward Transconductance	V <sub>DS</sub> =10V, I <sub>D</sub> =1A		5		S
V <sub>SD</sub>	Diode Forward Voltage	V <sub>GS</sub> =0V, I <sub>S</sub> =1A			1	V
<b>Dynamic</b>						
Q <sub>g</sub>	Total Gate Charge	V <sub>DS</sub> =50V, V <sub>GS</sub> =10V, I <sub>D</sub> =2A		13.4	21	nC
Q <sub>gs</sub>	Gate-Source Charge			2.9	6	
Q <sub>gd</sub>	Gate-Drain Charge			1.7	4	
C <sub>iss</sub>	Input Capacitance	V <sub>DS</sub> =50V, V <sub>GS</sub> =0V, f=1MHz		820	1190	pF
C <sub>oss</sub>	Output Capacitance			35	55	
C <sub>rss</sub>	Reverse Transfer Capacitance			20	30	
t <sub>d(on)</sub>	Turn-On Time	V <sub>DD</sub> =30V, I <sub>D</sub> =1A, V <sub>GS</sub> =10V, R <sub>G</sub> =3.3Ω		1.6	3	ns
t <sub>r</sub>				6.6	13	
t <sub>d(off)</sub>	Turn-Off Time			11.5	22	
t <sub>f</sub>				3.6	7	
R <sub>g</sub>	Gate Resistance		V <sub>DS</sub> =0V, V <sub>GS</sub> =0V, f=1MHz		1.3	

## Typical Performance Characteristics

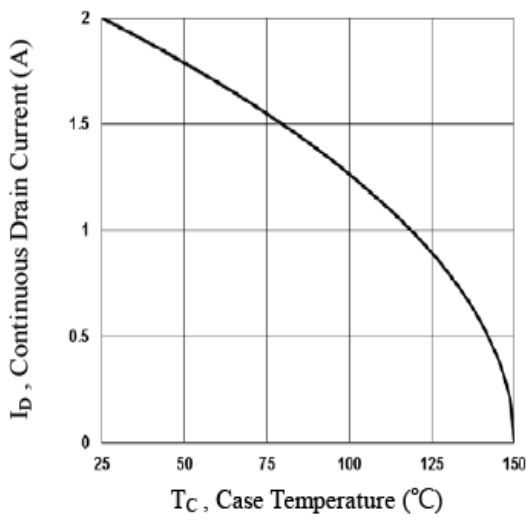

**Fig.1 Continuous Drain Current vs.  $T_c$**

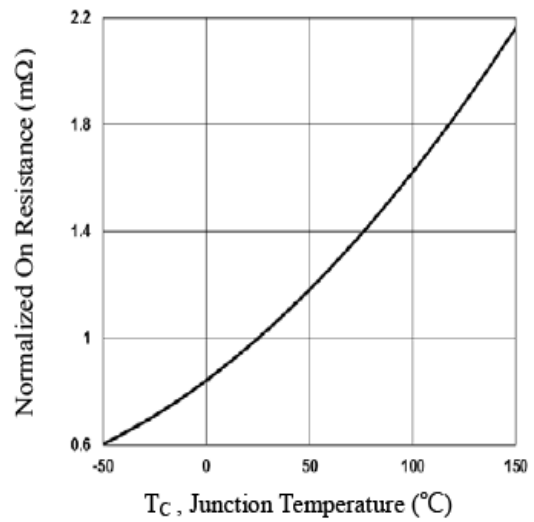

**Fig.2 Continuous Drain Current vs.  $T_c$**

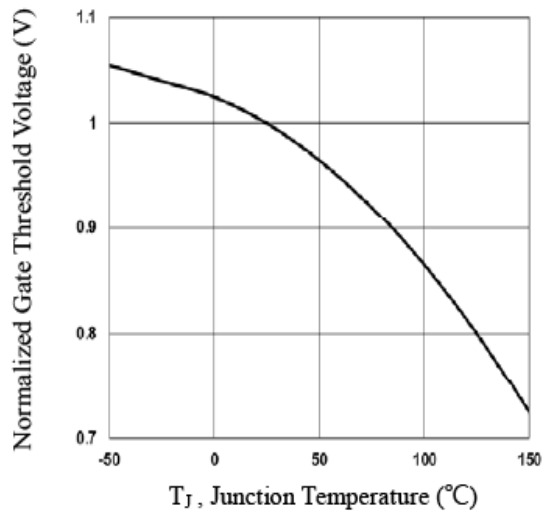

**Fig.3 Normalized  $V_{th}$  vs.  $T_j$**

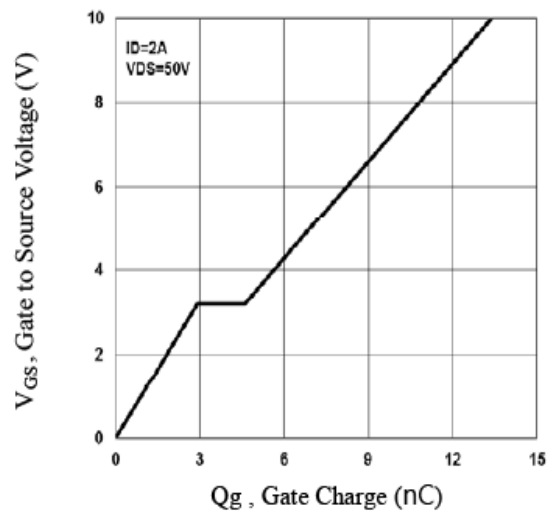

**Fig.4 Gate Charge Waveform**

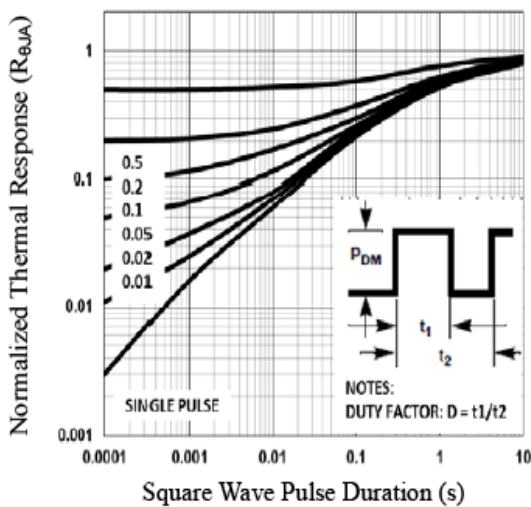

**Fig.5 Normalized Transient Impedance**

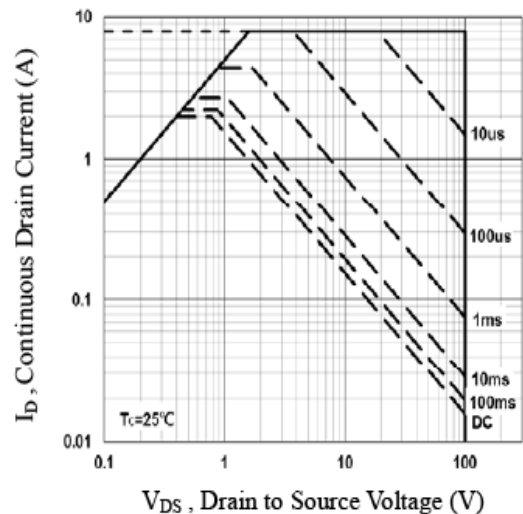

**Fig.6 Maximum Safe Operation Area**

## Typical Performance Characteristics (Continue)

### Gate Charge Test Circuit & Waveform

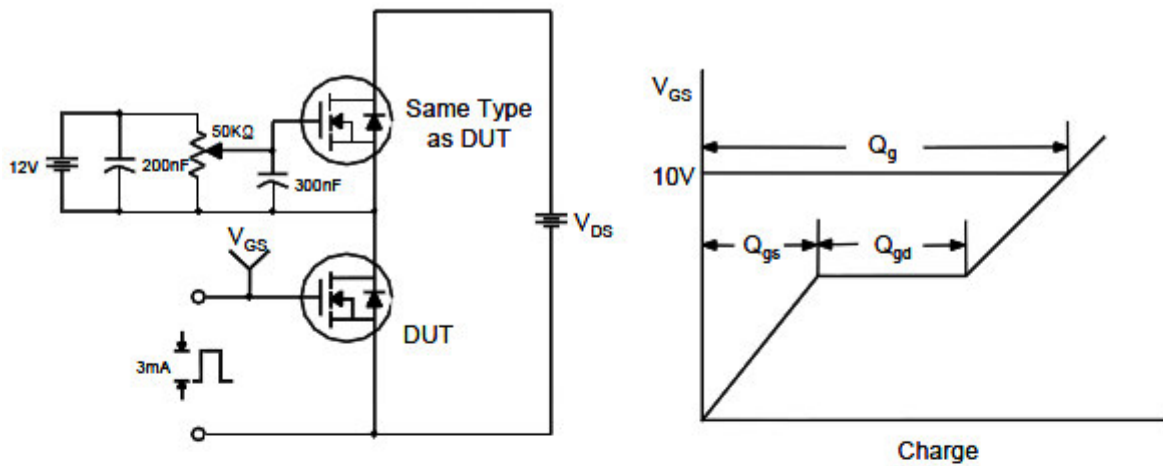

### Resistive Switching Test Circuit & Waveforms



### Unclamped Inductive Switching Test Circuit & Waveforms



## Package Dimension

### SOT-23

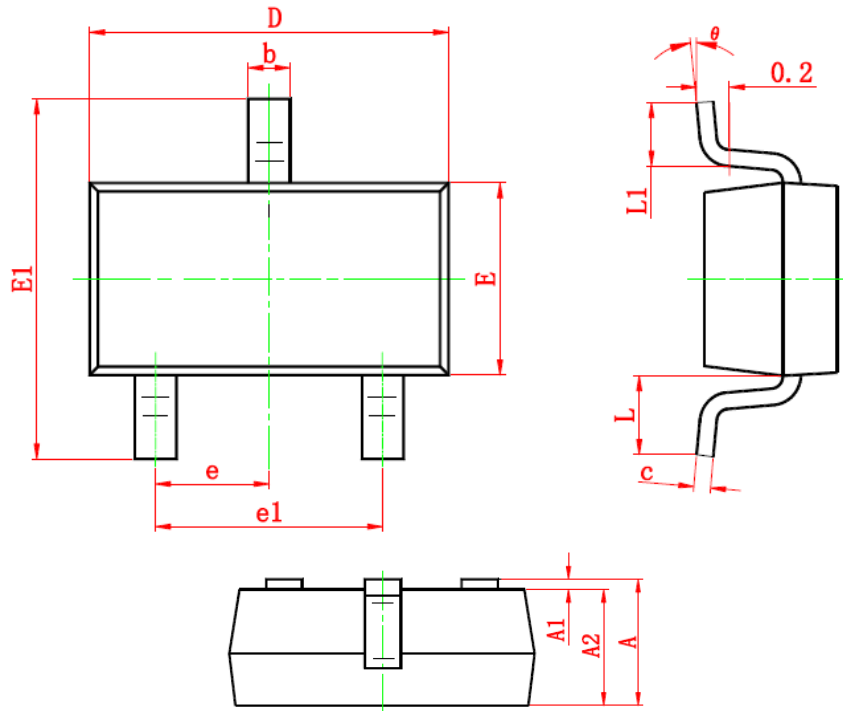







Dimensions				
Symbol	Millimeters		Inches	
	Min	Max	Min	Max
<b>A</b>	0.900	1.200	0.035	0.043
<b>A1</b>	0.000	0.100	0.000	0.004
<b>A2</b>	0.900	1.100	0.035	0.039
<b>b</b>	0.300	0.500	0.012	0.020
<b>c</b>	0.080	0.150	0.003	0.006
<b>D</b>	2.800	3.000	0.110	0.118
<b>E</b>	1.200	1.400	0.047	0.055
<b>E1</b>	2.250	2.550	0.089	0.100
<b>e</b>	0.950 TYP		0.037 TYP	
<b>e1</b>	1.800	2.000	0.071	0.079
<b>L</b>	0.550 REF		0.022 REF	
<b>L1</b>	0.300	0.500	0.012	0.020
<b>θ</b>	0°	8°	0°	6°



## NOTICE

Information furnished is believed to be accurate and reliable. However Globaltech Semiconductor assumes no responsibility for the consequences of use of such information nor for any infringement of patents or other rights of third parties, which may result from its use. No license is granted by implication or otherwise under any patent or patent rights of Globaltech Semiconductor. Specifications mentioned in this publication are subject to change without notice. This publication supersedes and replaces all information without express written approval of Globaltech Semiconductor.

## CONTACT US

GS Headquarter	
	4F.,No.43-1,Lane11,Sec.6,Minquan E.Rd Neihu District Taipei City 114, Taiwan (R.O.C)
	886-2-2657-9980
	886-2-2657-3630
	sales_twn@gs-power.com

Shenzhen Branch(China)	
	1113 B Building, Happiness Washington, Baoan Nan Road, Luohu District, Shenzhen City, China
	0755-22208941
	sales_cn@gs-power.com

RD Division	
	824 Bolton Drive Milpitas. CA. 95035
	1-408-457-0587