

GSR811

Reset IC

Product Description

The GSR811 are microprocessor (μ P) supervisory circuits used to monitor the power supplies in μ P and digital systems. They provide excellent circuit reliability and low cost by eliminating external components and adjustments when used with +3.3V, +3.0V, or 2.5V powered circuits.

These circuits perform a single function: they assert a reset signal whenever the V_{CC} supply voltage declines below a preset threshold or Manual -reset, keeping it asserted for at least 140ms. Reset thresholds suitable for operation with a variety of supply voltages are available.

The GSR811 have push-pull outputs and have an active-low /RESET output. The reset comparator is designed to ignore fast transients on V_{CC} , and the outputs are guaranteed to be in the correct logic state for V_{CC} down to 1V. Low supply current makes the GSR811 ideal for use in portable equipment. The ICs are available in SOT-143 packages.

Features

- Precision supply-voltage monitor
 - 4.30V (GSR811M)
 - 4.00V (GSR811J)
 - 3.08V (GSR811T)
 - 2.93V (GSR811S)
 - 2.63V (GSR811R)
 - 2.32V (GSR811Z)
 - 1.5V~2.2V (Contact us)
- 140ms(min) reset pulse width
- Push-Pull /RESET Output Configurations
- Debounced CMOS-compatible manual-reset input
- 12 μ A Supply Current
- Guaranteed Reset(/Reset) Valid to $V_{CC}=+1.0V$
- Power Supply Transient Immunity
- No External Components
- RoHS Compliant, 100%Pb & Halogen Free

Applications

- Microprocessor reset circuitry
- Computers & Wireless
- Embedded Control Systems
- Battery-operated systems

Block Diagram

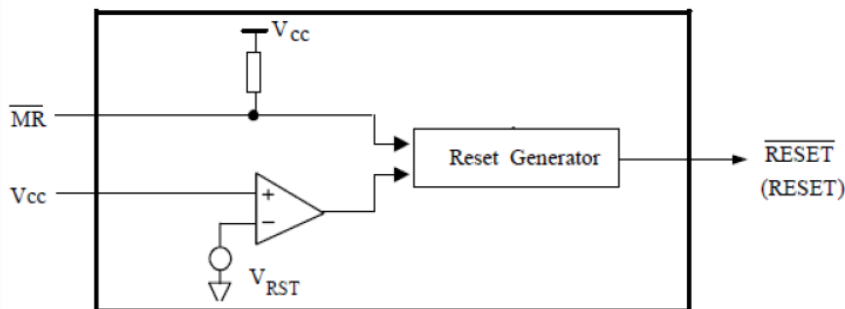

Packages & Pin Assignments (Top View)

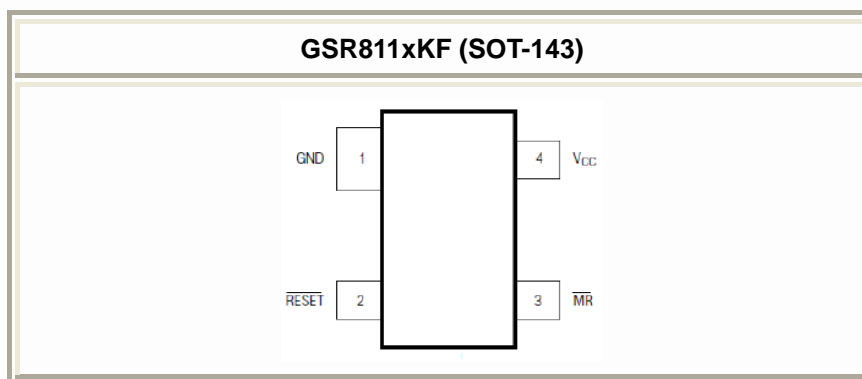

Pin Description

| Name | Type | Description |
|-----------------|------|---|
| V _{CC} | - | Supply Voltage. Reset is asserted when V _{CC} drops below the Reset Threshold Voltage (V _{RST}). Reset remains asserted until V _{CC} rises above V _{RST} and keep asserted for the duration of the Reset Timeout Period (t _{RS}) once V _{CC} rises above V _{RST} . |
| GND | - | Ground Pin. |
| /RESET | O | Active-Low Reset Output (Push-Pull). It goes low when V _{CC} is below the reset threshold. It remains low for about 200ms after V _{CC} rises above the reset threshold (V _{RST}). |
| /MR | I | Manual-Reset: (CMOS). Active low. Pull low to force a reset. Reset remains asserted for the duration of the Reset Timeout Period after MR transitions from low to high. Leave unconnected or connected to V _{CC} if not used. |

Ordering Information

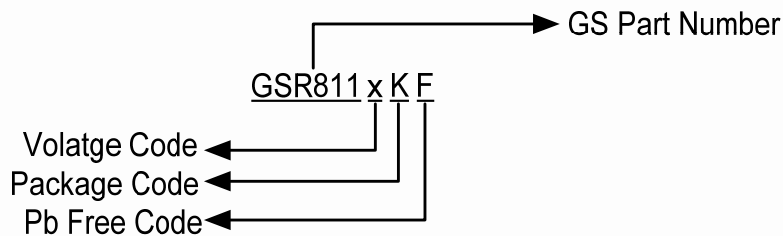

Voltage Code : As following Table :

| x | M | J | T | S | R | Z |
|-----------------|-------|-------|-------|-------|-------|-------|
| Reset Threshold | 4.30V | 4.00V | 3.08V | 2.93V | 2.63V | 2.32V |

Marking Information

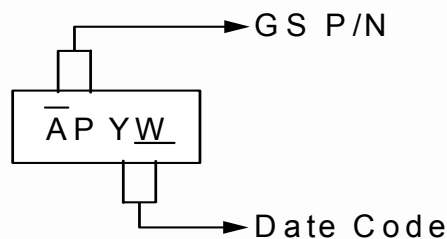

| GS P/N | Package | Marking | Reset Threshold |
|-----------|---------|---------|-----------------|
| GSR811MKF | SOT-143 | APYW | 4.30V |
| GSR811JKF | SOT-143 | AUYW | 4.00V |
| GSR811TKF | SOT-143 | AQYW | 3.08V |
| GSR811SKF | SOT-143 | ARYW | 2.93V |
| GSR811RKF | SOT-143 | ASYW | 2.63V |
| GSR811ZKF | SOT-143 | ATYW | 2.32V |

Note: Year and Work Week must use the actual time of molding process.

Functional Description

Reset Output

A microprocessor (μP) reset input starts the μP in a known state. Whenever the μP is in an unknown state, it should be held in reset. The supervisory circuits assert reset during power-up and prevent code execution errors during power-down or brownout conditions.

On power-up, once V_{CC} reaches about 1.0V, $\overline{\text{RESET}}$ is a guaranteed logic low of 0.4V or less. As V_{CC} rises, $\overline{\text{RESET}}$ stays low. When V_{CC} rises above the reset threshold, an internal timer releases $\overline{\text{RESET}}$ after about 200ms. $\overline{\text{RESET}}$ pulses low whenever V_{CC} drops below the reset threshold, i.e. brownout condition. If brownout occurs in the middle of a previously initiated reset pulse, the pulse continues for at least another 200ms. On power-down, once V_{CC} falls below the reset threshold, $\overline{\text{RESET}}$ stays low and is guaranteed to be 0.4V or less until V_{CC} drops below 1.0V. Reset timing diagram shows the timing relationship.

Manual Reset

The manual-reset input (MR) allows reset to be triggered by a push button switch. MR has an internal pull up resistor, so it can be left open when not used.

Absolute Maximum Ratings

| Symbol | Parameter | Value | Unit |
|------------------|-------------------------------------|-----------------------------|--------------------|
| V_{CC} | Supply Voltage to Ground Potential | -0.3 to +6.0 | V |
| - | All Other Pins Voltage | -0.3 to $V_{\text{CC}}+0.3$ | V |
| I_{OUT} | Output Current | 20 | mA |
| P_{D} | Power Dissipation | 320 | mW |
| T_{A} | Operating Ambient Temperature Range | -40 to +85 | $^{\circ}\text{C}$ |
| T_{STG} | Storage Temperature Range | -55 to +150 | $^{\circ}\text{C}$ |

Note: Stresses greater than those listed under maximum ratings may cause permanent damage to the device. This is a stress rating only and functional operation of the device at these or any other conditions above those indicated in the operational sections of this specification is not implied. Exposure to absolute maximum rating conditions for extended periods may affect reliability.

Recommended Operation Conditions

| Symbol | Parameter | Min | Typ | Max | Unit |
|-----------------|-------------------------------------|-----|-----|-----|--------------------|
| V_{CC} | Supply Voltage for GSR811(L/M) | 4.5 | 5.0 | 5.5 | V |
| | Supply Voltage for GSR811(T/S) | 3.0 | 3.3 | 5.5 | |
| | Supply Voltage for GSR811(R) | 2.7 | 3.0 | 5.5 | |
| T_{A} | Operating Ambient Temperature Range | -40 | - | 85 | $^{\circ}\text{C}$ |

Reset Timing Diagram

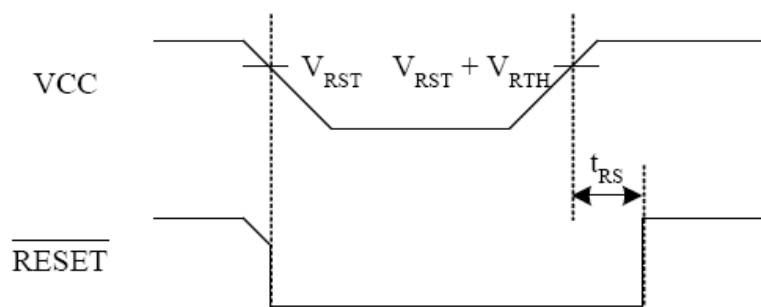

Electrical Characteristics

($V_{CC}=V_{RN}+5\%$ to 5.5V, $T_A=-40$ to 85°C, unless otherwise noted.) (Note 1)

| Symbol | Parameter | Conditions | Min | Typ | Max | Unit |
|-----------------------------|---|--|--------------------|----------|----------------|---------|
| V_{CC} | Operating Voltage Range | - | 1.0 | - | 5.5 | V |
| I_{CC} | Supply Current | $V_{CC}<5.5V$, GSR811(L/M) | - | 10 | 30 | μA |
| | | $V_{CC}<3.6V$, GSR811(R/S/T/Z) | - | 10 | 30 | μA |
| V_{RST} (V_{RTH-}) | Threshold Voltage (Falling Edge) Note 2 | GSR811M, $T_A=25^\circ C$ | $V_{RN}-1.1\%$ | V_{RN} | $V_{RN}+1.1\%$ | V |
| | | All except GSR811M, $T_A=25^\circ C$ | $V_{RN}-1.5\%$ | V_{RN} | $V_{RN}+1.5\%$ | |
| | | GSR811M, $T_A=-40$ to 85°C | $V_{RN}-1.8\%$ | V_{RN} | $V_{RN}+2\%$ | |
| | | All except GSR811M, $T_A=-40$ to 85°C | $V_{RN}-2.5\%$ | V_{RN} | $V_{RN}+2.5\%$ | |
| V_{RTH+} | Threshold Voltage (Rising-edge) (Note 2) | GSR811M, $T_A=-40$ to 85°C | 4.232 | 4.31 | 4.396 | V |
| V_{RTH} | Reset Threshold Hysteresis (Note 2) | V_{CC} varies between $V_{RN}\pm 5\%$ (Only for GSR811L/M) | - | 50 | - | mV |
| V_{OH} | Output High Voltage | $V_{CC}\geq 4.5V$, $I_{SOURCE}=800\mu A$ | $V_{CC}-1.5$ | - | - | V |
| | | $V_{CC}\geq 2.7V$, $I_{SOURCE}=500\mu A$ | $0.8\times V_{CC}$ | - | - | |
| | | $V_{CC}\geq 1.8V$, $I_{SOURCE}=150\mu A$ | $0.8\times V_{CC}$ | - | - | |
| | | $V_{CC}\geq 1.0V$, $I_{SOURCE}=4\mu A$ | $0.8\times V_{CC}$ | - | - | |
| V_{OL} | Output Low Voltage | $V_{CC}\geq 4.5V$, $I_{SINK}=3.2mA$ | - | - | 0.4 | V |
| | | $V_{CC}\geq 2.7V$, $I_{SINK}=1.2mA$ | - | - | 0.3 | |
| | | $V_{CC}\geq 1.0V$, $I_{SINK}=100\mu A$ | - | - | 0.3 | |

Note: 1. Parameters of room temperature guaranteed by production test and parameters of full-temperature guaranteed by design.

2. V_{RST} is Reset threshold voltage when V_{CC} falls from high to low level. V_{RN} is nominal reset threshold voltage.

AC Electrical Characteristics

| Symbol | Parameter | Conditions | Min | Typ | Max | Unit |
|----------|-------------------|------------------|-----|-----|-----|---------|
| t_{RS} | Reset Pulse Width | $T_A=25^\circ C$ | 140 | 200 | 280 | ms |
| t_{MR} | MR Pulse Width | $T_A=25^\circ C$ | 1 | - | - | μs |

Package Dimension

SOT-143 PLASTIC PACKAGE

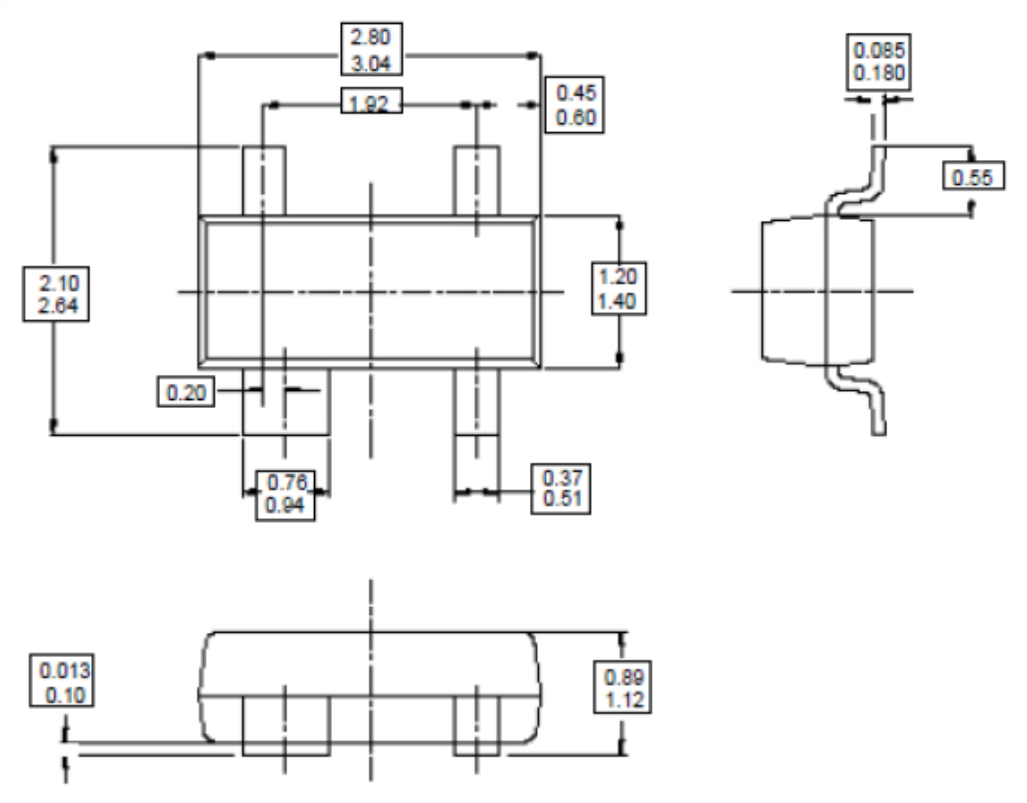





- Note:
- 1. Controlling dimensions in millimeters.
 - 2. Dimensions are inclusive of plating.



NOTICE

Information furnished is believed to be accurate and reliable. However Globaltech Semiconductor assumes no responsibility for the consequences of use of such information nor for any infringement of patents or other rights of third parties, which may result from its use. No license is granted by implication or otherwise under any patent or patent rights of Globaltech Semiconductor. Specifications mentioned in this publication are subject to change without notice. This publication supersedes and replaces all information without express written approval of Globaltech Semiconductor.

CONTACT US

| GS Headquarter | |
|---|--|
|  | 4F.,No.43-1,Lane11,Sec.6,Minquan E.Rd NeiHu District Taipei City 114, Taiwan (R.O.C) |
|  | 886-2-2657-9980 |
|  | 886-2-2657-3630 |
|  | sales_twn@gs-power.com |

| Wu-Xi Branch | |
|---|--|
|  | No.21 Changjiang Rd., WND, Wuxi, Jiangsu, China (INFO. & TECH. Science Park Building A 210 Room) |
|  | 86-510-85217051 |
|  | 86-510-85211238 |
|  | sales_cn@gs-power.com |

| RD Division | |
|---|--------------------------------------|
|  | 824 Bolton Drive Milpitas. CA. 95035 |
|  | 1-408-457-0587 |