

SMT Shielded Power Inductors

GSRH4D18 / GSRH4D28 / GSRH5D18

GSRH5D28 / GSRH6D28 / GSRH6D38

 另存新檔 [上一頁](#) [下一頁](#)

Features (特長)

Magnetically shielded construction (閉磁路構造設計)

Compact and thin (輕便薄小)

Large Current and Low DCR (大電流低直流阻抗)

Applications (用途)

DC-DC converter of portable equipment. (攜帶機器之直流轉換器)

Camcorder, LCD television set, Digital camera, P.D.A., Notebook. (攝影機、液晶電視、數位相機、P.D.A.、筆記型電腦)

Product Identification (產品識別)

GSRH4D18 - ____ ____ (Ex. GSRH4D18-1R0M)

1 2 3

(1) SMT Shielded Power Inductors (閉磁式功率電感)

(GSRH4D18, GSRH4D28, GSRH5D18, GSRH5D28, GSRH6D28,

GSRH6D38)

(2) Inductance (電感值)

(3) Tolerance (誤差值) (K 10%, L 15%, M 20%, N 30%)



Configurations & Dimensions (結構圖及規格尺寸)

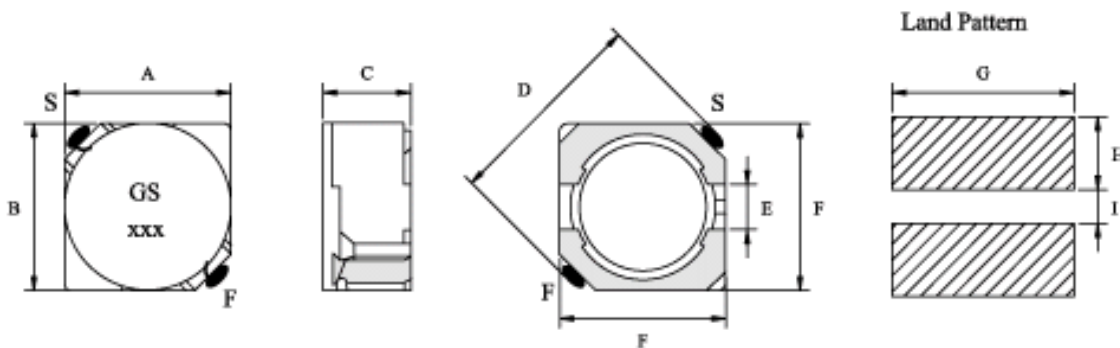

Type (型式)	A ± 0.3	B ± 0.3	C (max)	D (max)	E (Ref.)	F (Ref.)	G	H	I
GSRH4D18	4.7	4.7	2.0	6.9	1.5	4.5	5.3	1.90	1.5
GSRH4D28	4.7	4.7	3.0	6.9	1.5	4.5	5.3	1.90	1.5
GSRH5D18	5.7	5.7	2.0	8.2	2.0	5.5	6.3	2.15	2.0
GSRH5D28	5.7	5.7	3.0	8.2	2.0	5.5	6.3	2.15	2.0
GSRH6D28	6.7	6.7	3.0	9.5	2.0	6.5	7.3	2.65	2.0
GSRH6D38	6.7	6.7	4.0	9.5	2.0	6.5	7.3	2.65	2.0

Design as Customer's Requested Specifications. (可依客戶特殊需求設計)

GSRH4D18

Electrical Characteristics for GSRH4D18 Series [GSRH4D18系列電子特性規格]

Part Number 產品料號	Inductance (μ H) 電感值 (L)	Test Freq. (KHz) 測試頻率	DCR (W) (max) 直流阻抗	IDC (A) (max) 定格電流
GSRH4D18 -1R0N	1.00	100	0.045	1.72
GSRH4D18 -2R2N	2.20	100	0.075	1.32
GSRH4D18 -2R7N	2.70	100	0.105	1.28
GSRH4D18 -3R3N	3.30	100	0.110	1.04
GSRH4D18 -3R9N	3.90	100	0.155	0.88
GSRH4D18 -4R7N	4.70	100	0.162	0.84
GSRH4D18 -5R6N	5.60	100	0.170	0.80
GSRH4D18 -6R8N	6.80	100	0.200	0.76
GSRH4D18 -8R2N	8.20	100	0.245	0.68
GSRH4D18 -100M	10.00	100	0.200	0.61
GSRH4D18 -120M	12.00	100	0.210	0.56
GSRH4D18 -150M	15.00	100	0.240	0.50
GSRH4D18 -180M	18.00	100	0.338	0.48
GSRH4D18 -220M	22.00	100	0.397	0.41
GSRH4D18 -270M	27.00	100	0.441	0.35
GSRH4D18 -330M	33.00	100	0.694	0.32
GSRH4D18 -390M	39.00	100	0.709	0.30
GSRH4D18 -470M	47.00	100	0.922	0.28
GSRH4D18 -560M	56.00	100	1.080	0.26
GSRH4D18 -680M	68.00	100	1.300	0.24
GSRH4D18 -820M	82.00	100	1.550	0.22

GSRH4D18 -101M	100.00	100	1.730	0.20
GSRH4D18 -121M	120.00	100	2.390	0.18
GSRH4D18 -151M	150.00	100	2.670	0.15
GSRH4D18 -181M	180.00	100	4.000	0.14

Test Freq. : 100KHz / 0.1V.

Operating Temp. : - 40 ~ + 85

Inductance drop = 35% typ. at IDC.

GSRH4D28

Electrical Characteristics for GSRH4D28 Series [GSRH4D28系列電子特性規格]

Part Number 產品料號	Inductance (μ H) 電感值 (L)	Test Freq. (KHz) 測試頻率	DCR (W) (max) 直流阻抗	IDC (A) (max) 定格電流
GSRH4D28 -1R2N	1.20	100	0.0236	2.56
GSRH4D28 -1R8N	1.80	100	0.0275	2.20
GSRH4D28 -2R2N	2.20	100	0.0313	2.04
GSRH4D28 -2R7N	2.70	100	0.0433	1.60
GSRH4D28 -3R3N	3.30	100	0.0492	1.57
GSRH4D28 -3R9N	3.90	100	0.0648	1.44
GSRH4D28 -4R7N	4.70	100	0.0720	1.32
GSRH4D28 -5R6N	5.60	100	0.1009	1.17
GSRH4D28 -6R8N	6.80	100	0.1089	1.12
GSRH4D28 -8R2N	8.20	100	0.1175	1.04
GSRH4D28 -100M	10.00	100	0.1283	1.00
GSRH4D28 -120M	12.00	100	0.1316	0.84
GSRH4D28 -150M	15.00	100	0.1490	0.76
GSRH4D28 -180M	18.00	100	0.1660	0.72
GSRH4D28 -220M	22.00	100	0.2350	0.70
GSRH4D28 -270M	27.00	100	0.2610	0.58
GSRH4D28 -330M	33.00	100	0.3780	0.56
GSRH4D28 -390M	39.00	100	0.3837	0.50
GSRH4D28 -470M	47.00	100	0.5870	0.48
GSRH4D28 -560M	56.00	100	0.6245	0.41
GSRH4D28 -680M	68.00	100	0.6990	0.35
GSRH4D28 -820M	82.00	100	0.9148	0.32
GSRH4D28 -101M	100.00	100	1.020	0.29
GSRH4D28 -121M	120.00	100	1.270	0.27

GSRH4D28 -151M	150.00	100	1.350	0.24
GSRH4D28 -181M	180.00	100	1.540	0.22
GSRH4D28 -221M	220.00	100	1.720	0.20
GSRH4D28 -271M	270.00	100	1.950	0.16
GSRH4D28 -331M	330.00	100	2.660	0.14
GSRH4D28 -391M	390.00	100	2.830	0.13

Test Freq. : 100KHz / 0.1V.

Operating Temp. : - 40 ~ + 85

Inductance drop = 35% typ. at IDC.

GSRH5D18

Electrical Characteristics for GSRH5D18 Series [GSRH5D18 系列電子特性規格]

Part Number 產品料號	Inductance (μ H) 電感值 (L)	Test Freq. (KHz) 測試頻率	DCR (W) (max) 直流阻抗	IDC (A) (max) 定格電流
GSRH5D18 -4R1N	4.10	10	0.057	1.95
GSRH5D18 -5R4N	5.40	10	0.076	1.60
GSRH5D18 -6R2N	6.20	10	0.096	1.40
GSRH5D18 -8R9N	8.90	10	0.116	1.25
GSRH5D18 -100M	10.00	10	0.124	1.20
GSRH5D18 -120M	12.00	10	0.153	1.10
GSRH5D18 -150M	15.00	10	0.196	0.97
GSRH5D18 -180M	18.00	10	0.210	0.85
GSRH5D18 -220M	22.00	10	0.290	0.80
GSRH5D18 -270M	27.00	10	0.330	0.75
GSRH5D18 -330M	33.00	10	0.386	0.65
GSRH5D18 -390M	39.00	10	0.520	0.57
GSRH5D18 -470M	47.00	10	0.595	0.54
GSRH5D18 -560M	56.00	10	0.665	0.50
GSRH5D18 -680M	68.00	10	0.840	0.43
GSRH5D18 -820M	82.00	10	0.978	0.41
GSRH5D18 -101M	100.00	10	1.200	0.36
GSRH5D18 -121M	120.00	10	1.500	0.33
GSRH5D18 -151M	150.00	10	1.710	0.31
GSRH5D18 -181M	180.00	10	2.240	0.28
GSRH5D18 -221M	220.00	10	2.440	0.23

GSRH5D18 -271M	270.00	10	3.380	0.21
GSRH5D18 -331M	330.00	10	4.340	0.18

Test Freq. : 10KHz / 0.1V.

Operating Temp. : - 40 ~ + 85

Inductance drop = 35% typ. at IDC.

GSRH5D28

Electrical Characteristics for GSRH5D28 Series [GSRH5D28 系列電子特性規格]

Part Number 產品料號	Inductance (μ H) 電感值 (L)	Test Freq. (KHz) 測試頻率	DCR (W) (max) 直流阻抗	IDC (A) (max) 定格電流
GSRH5D28 -2R6N	2.60	10	0.018	2.60
GSRH5D28 -3R0N	3.00	10	0.024	2.40
GSRH5D28 -4R2N	4.20	10	0.031	2.20
GSRH5D28 -5R3N	5.30	10	0.038	1.90
GSRH5D28 -6R2N	6.20	10	0.045	1.80
GSRH5D28 -8R2N	8.20	10	0.053	1.60
GSRH5D28 -100M	10.00	10	0.065	1.30
GSRH5D28 -120M	12.00	10	0.076	1.20
GSRH5D28 -150M	15.00	10	0.103	1.10
GSRH5D28 -180M	18.00	10	0.110	1.00
GSRH5D28 -220M	22.00	10	0.122	0.90
GSRH5D28 -270M	27.00	10	0.175	0.85
GSRH5D28 -330M	33.00	10	0.189	0.75
GSRH5D28 -390M	39.00	10	0.212	0.70
GSRH5D28 -470M	47.00	10	0.260	0.62
GSRH5D28 -560M	56.00	10	0.305	0.58
GSRH5D28 -680M	68.00	10	0.355	0.52
GSRH5D28 -820M	82.00	10	0.463	0.46
GSRH5D28 -101M	100.00	10	0.520	0.42
GSRH5D28 -121M	120.00	10	0.560	0.40
GSRH5D28 -151M	150.00	10	0.680	0.35
GSRH5D28 -181M	180.00	10	0.930	0.32
GSRH5D28 -221M	220.00	10	1.150	0.30
GSRH5D28 -271M	270.00	10	1.560	0.27
GSRH5D28 -331M	330.00	10	1.980	0.25

GSRH5D28 -391M	390.00	10	2.500	0.22
GSRH5D28 -471M	470.00	10	2.700	0.20
GSRH5D28 -561M	560.00	10	3.120	0.18
GSRH5D28 -681M	680.00	10	4.150	0.16

Test Freq. : 10KHz / 0.1V.

Operating Temp. : - 40 ~ + 85

Inductance drop = 35% typ. at IDC.

GSRH6D28

Electrical Characteristics for GSRH6D28 Series [GSRH6D28 系列電子特性規格]

Part Number 產品料號	Inductance (μ H) 電感值 (L)	Test Freq. (KHz) 測試頻率	DCR (W) (max) 直流阻抗	IDC (A) (max) 定格電流
GSRH6D28 -3R0N	3.00	10	0.024	3.00
GSRH6D28 -3R9N	3.90	10	0.027	2.60
GSRH6D28 -5R0N	5.00	10	0.031	2.40
GSRH6D28 -6R0N	6.00	10	0.035	2.25
GSRH6D28 -7R3N	7.30	10	0.054	2.10
GSRH6D28 -8R6N	8.60	10	0.058	1.85
GSRH6D28 -100M	10.00	10	0.065	1.70
GSRH6D28 -120M	12.00	10	0.070	1.55
GSRH6D28 -150M	15.00	10	0.084	1.40
GSRH6D28 -180M	18.00	10	0.095	1.32
GSRH6D28 -220M	22.00	10	0.128	1.20
GSRH6D28 -270M	27.00	10	0.142	1.05
GSRH6D28 -330M	33.00	10	0.165	0.97
GSRH6D28 -390M	39.00	10	0.210	0.86
GSRH6D28 -470M	47.00	10	0.238	0.80
GSRH6D28 -560M	56.00	10	0.277	0.73
GSRH6D28 -680M	68.00	10	0.304	0.65
GSRH6D28 -820M	82.00	10	0.390	0.60
GSRH6D28 -101M	100.00	10	0.535	0.54
GSRH6D28 -121M	120.00	10	0.750	0.51
GSRH6D28 -151M	150.00	10	0.950	0.47
GSRH6D28 -181M	180.00	10	1.200	0.41
GSRH6D28 -221M	220.00	10	1.500	0.37
GSRH6D28 -271M	270.00	10	1.700	0.33

GSRH6D28 -331M	330.00	10	2.150	0.28
GSRH6D28 -391M	390.00	10	2.250	0.27
GSRH6D28 -471M	470.00	10	3.150	0.21
GSRH6D28 -561M	560.00	10	3.750	0.20
GSRH6D28 -681M	680.00	10	5.150	0.20

Test Freq. : 10KHz / 0.1V.

Operating Temp. : - 40 ~ + 85

Inductance drop = 35% typ. at IDC.

GSRH6D38

Electrical Characteristics for GSRH6D38 Series [GSRH6D38系列電子特性規格]

Part Number 產品料號	Inductance (μ H) 電感值 (L)	Test Freq. (KHz) 測試頻率	DCR (W) (max) 直流阻抗	IDC (A) (max) 定格電流
GSRH6D38 -3R3N	3.30	10	0.020	3.50
GSRH6D38 -5R0N	5.00	10	0.024	2.90
GSRH6D38 -6R2N	6.20	10	0.027	2.50
GSRH6D38 -7R4N	7.40	10	0.031	2.30
GSRH6D38 -8R7N	8.70	10	0.034	2.20
GSRH6D38 -100M	10.00	10	0.038	2.00
GSRH6D38 -120M	12.00	10	0.053	1.70
GSRH6D38 -150M	15.00	10	0.057	1.60
GSRH6D38 -180M	18.00	10	0.092	1.50
GSRH6D38 -220M	22.00	10	0.096	1.30
GSRH6D38 -270M	27.00	10	0.109	1.20
GSRH6D38 -330M	33.00	10	0.124	1.10
GSRH6D38 -390M	39.00	10	0.138	1.00
GSRH6D38 -470M	47.00	10	0.155	0.95
GSRH6D38 -560M	56.00	10	0.202	0.85
GSRH6D38 -680M	68.00	10	0.234	0.75
GSRH6D38 -820M	82.00	10	0.324	0.70
GSRH6D38 -101M	100.00	10	0.358	0.65
GSRH6D38 -121M	120.00	10	0.470	0.59
GSRH6D38 -151M	150.00	10	0.580	0.54
GSRH6D38 -181M	180.00	10	0.690	0.49
GSRH6D38 -221M	220.00	10	0.890	0.43
GSRH6D38 -271M	270.00	10	1.290	0.40

GSRH6D38 -331M	330.00	10	1.700	0.37
GSRH6D38 -391M	390.00	10	1.750	0.34
GSRH6D38 -471M	470.00	10	2.200	0.32
GSRH6D38 -561M	560.00	10	2.850	0.29
GSRH6D38 -681M	680.00	10	3.200	0.25
GSRH6D38 -821M	820.00	10	4.050	0.22
GSRH6D38 -102M	1000.00	10	5.700	0.20

Test Freq. : 10KHz / 0.1V.

Operating Temp. : - 40 ~ + 85

Inductance drop = 35% typ. at IDC.