

- ★ Designed to meet IEEE802.3ab requirement
- ★ Designed to meet IR 235^oC peak requirement
- ★ Primary inductance 350μH min. with 8mA DC Bias
- ★ Single Port for NIC Application

Specifications											
Part Number	Turn Ratio	Insertion Loss 1~100MHz (dB MAX)	Return Loss (MHz)					DMCM (dB)			Hi-Pot (Vrms MIN)
			1-30MHz	40MHz	50MHz	60-80MHz	100MHz	30MHz	60MHz	100MHz	
GT0001	1CT:1CT	1.0	-18dB	-14.4dB	-13.1dB	-12dB	10dB	-43db	-37dB	-33dB	1500
GT0002	1CT:1CT	1.0	-18dB	-14.4dB	-13.1dB	-12dB	10dB	-43db	-37dB	-33dB	1500

Mechanical

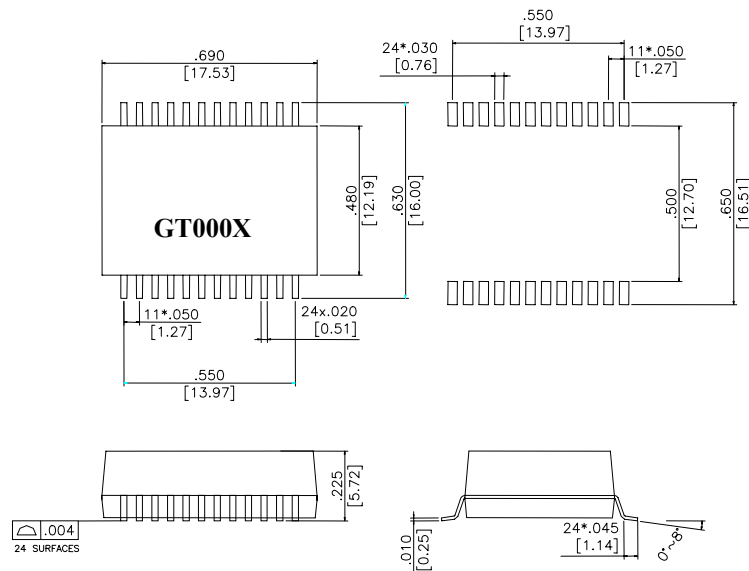

Data sheet subject to change without notice

Schematics

GT0001

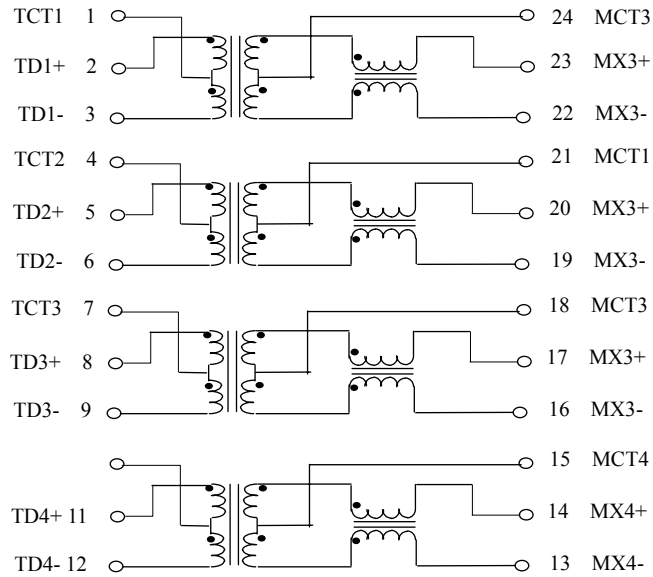

GT0002

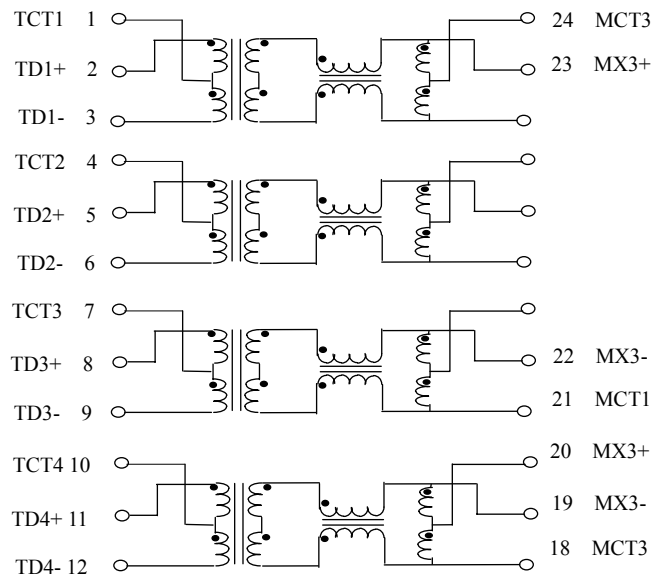

Data sheet subject to change without notice