

GT1151QM

Capacitive Touch Chip with Custom Gesture Wake-up Function

V0.1 — May 15, 2019

==== Disclaimer =====

The device application information and other similar content described in this publication are provided solely for your use and may be superseded by updated information. It is your own responsibility to ensure that the application complies with the specifications. GOODIX makes no representations or warranties, express or implied, written or oral, statutory or otherwise, including, but not limited to, representations or warranties of use, quality, performance, merchantability, or fitness for a particular purpose, with respect to this information. GOODIX assumes no responsibility for this information and the consequences of its use. GOODIX products may not be used as critical components in life support systems without the written approval of GOODIX. No license may be transferred, implicitly or otherwise, under GOODIX intellectual property protection.

Content

1. Overview.....	4
2. Features.....	4
3. Chip Principle Block Diagram.....	6
4. Pin Definition.....	7
5. Sensor Design.....	12
5.1. Sensing Channel Arrangement.....	12
5.2. Drive Channel Layout.....	12
5.3. Sensor Design Parameters Requirements.....	12
5.4. Touch Button Design.....	13
6. I ² C Communication.....	14
6.1 I ² C Communication.....	14
7. Function Description.....	18
7.1. Working mode.....	18
7.2. Sensitivity State Switching.....	19
7.3. Interrupt Trigger Mode.....	20
7.4. Fixed Configuration Function.....	20
7.5. Frequency Hopping Function.....	20
7.6. Self-calibration.....	21
8. Reference Circuit Diagram.....	22
9. Electrical Specification.....	23
9.1. Limit electrical parameters.....	23
9.2. Recommended working conditions.....	23

9.3. AC Characteristics	23
9.4. DC Characteristics	24
10. Product Packaging	25
11. SMT Reflow Soldering Requirements	26
11.1. Humidity Sensitive Level	26
11.2. Reflow Soldering Times	26
11.3. Lead-free Reflow Curve Diagram	27
12. Version Record	29
13. Contact	30

1. Overview

GT11 51 QM is a new generation 10-point capacitive touch scheme specially designed for 5 “~6” TP, with 16 drive channels and 29 sensing channels to meet higher touch accuracy requirements. In addition to meeting the basic high-precision touch, GT1151QM also provides differentiated functions such as glove operation, and full-screen multi-pen custom gesture wake-up.

2. Features

- ✧ Built-in capacitance detection circuit and high-performance MPU
 - Touch scanning frequency: $\leq 120\text{Hz}$
 - Real-time output of touch point coordinates
 - The unified software version is suitable for various sizes of mutual capacitance screens.
 - Single power supply with 1.8V LDO
 - Flash process, support online burning.

- ✧ Capacitance screen sensor
 - Detection channel: 45
 - Capacitor screen size range: 5 “~ 6”
 - Support FPC key design
 - Both ITO glass and ITO Film are supported.
 - Cover Lens thickness support: $0.4\text{mm} \cong \text{glass} \cong 2\text{mm}$, $0.4\text{mm} \cong \text{acrylic} \cong 1.2\text{mm}$
 - Built-in frequency hopping function supports OGS full fit.

- ✧ Custom gesture wake-up
 - Fixed gestures o, w, m, e, c, v, >, s, ←, ↓, ← →, <, single double-click.
 - Up to 10 multi-pen custom gestures
 - Provide so algorithm library for AP development

- ✧ Environmental adaptability

- Initialize automatic calibration
- Automatic temperature drift compensation
- Working temperature: -20°C~+85°C, humidity: ≅95%RH.

- ✧ Communication interface
 - Standard I²C communication interface
 - Slave working mode
 - Support interface level of 1.8V~3.3V

- ✧ Power supply
 - Single power supply (Typ.): 2.8V/3.0V/3.3V.

- ✧ Package: 58pins, qfn6x6x0.60, pitch 0.35mm.

- ✧ Application development support tool
 - Parameter detection of touch screen module and automatic generation of configuration parameters
 - Comprehensive test tool for performance of touch screen module
 - Module mass production test tool
 - Main control software development reference driver code and document guidance.

3. Chip Principle Block Diagram

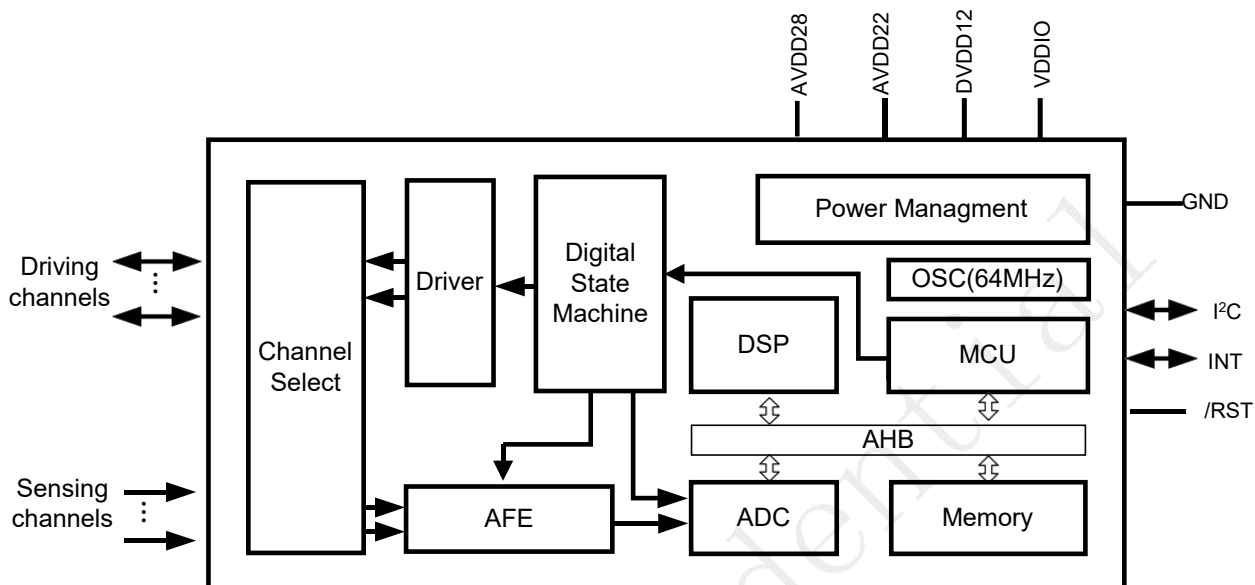

Goodix Confidential

4. Pin Definition

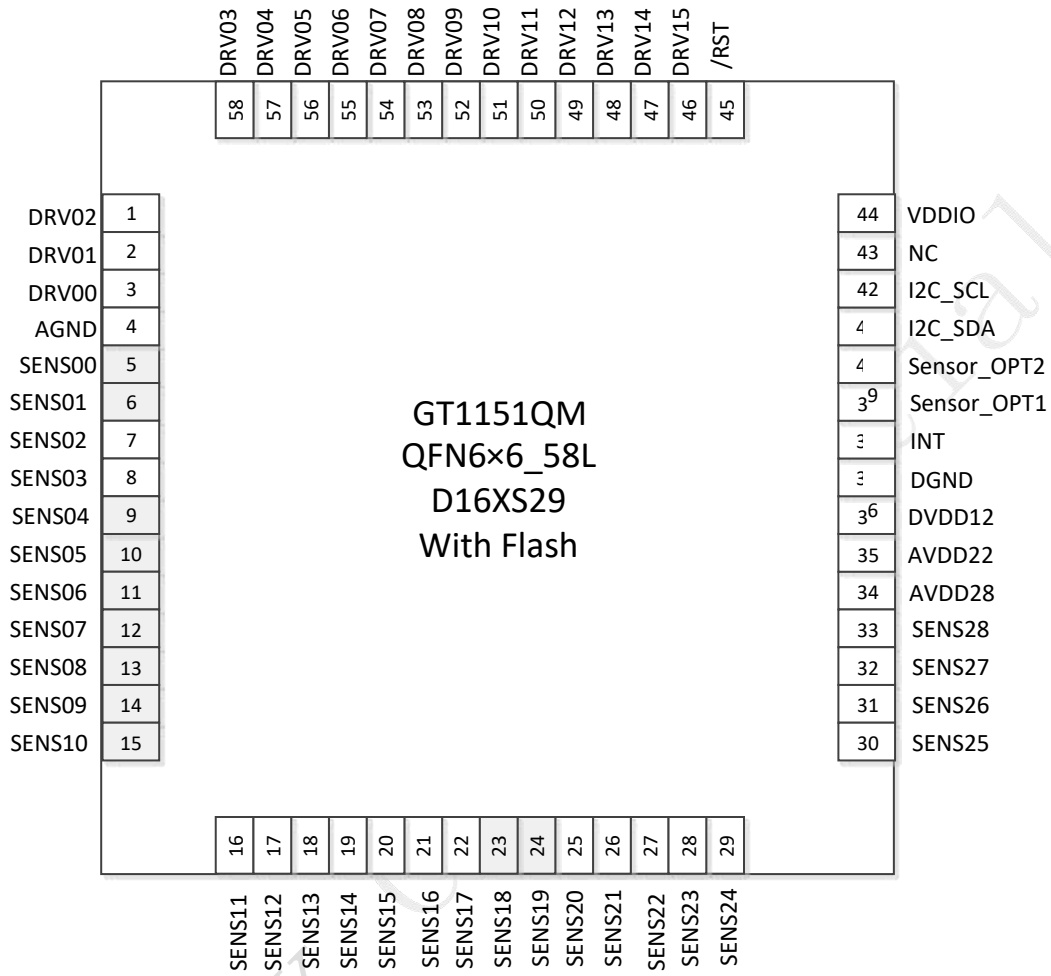

Pin No.	Name	Function Description	Remarks
1	DRV02	Touch drive signal output	
2	DRV01	Touch driver signal output	
3	DRV00	Touch drive signal output	
4	AGND	Analog ground	
5	SENS00	Touch analog signal input	

6	SENS01	Touch analog signal input	
7	SENS02	Touch analog signal input	
8	SENS03	Touch analog signal input	
9	SENS04	Touch analog signal input	
10	SENS05	Touch analog signal input	
11	SENS06	Touch analog signal input	
12	SENS07	Touch analog signal input	
13	SENS08	Touch analog signal input	
14	SENS09	Touch analog signal input	
15	SENS10	Touch analog signal input	
16	SENS11	Touch analog signal input	
17	SENS12	Touch analog signal input	
18	SENS13	Touch analog signal input	
19	SENS14	Touch analog signal input	
20	SENS15	Touch analog signal input	
21	SENS16	Touch analog signal input	
22	SENS17	Touch drive signal output	

23	SENS18	Touch analog signal input	
24	SENS19	Touch analog signal input	
25	SENS20	Touch analog signal input	
26	SENS21	Touch analog signal input	
27	SENS22	Touch analog signal input	
28	SENS23	Touch Analog Signal Input	
29	SENS24	Touch analog signal input	
30	SENS25	Touch analog signal input	
31	SENS26	Touch analog signal input	
32	SENS27	Touch analog signal input	
33	SENS28	Touch analog signal input	
34	AVDD28	Analog voltage input	Connect to 2.2uF filter capacitor
35	AVDD22	LDO output	Connect to 2.2uF filter capacitor
36	DVDD12	LDO output	Connect to 2.2uF filter capacitor
37	DGND	Digital ground	
38	INT	interrupt signal	
39	Sensor_OPT1	Module identification port	
40	Sensor_OPT2	Module	NC is not

		identification port	support
41	I2C_SDA	I2C data signal	
42	I2C_SCL	I2C clock signal	
43	NC		
44	VDDIO	GPIO level control	Connect to 2.2 UF filter capacitor NC: 1.8V Connect to AVDD: AVDD
45	/RST	System reset pin	Low active
46	DRV15	Touch drive signal output	
47	DRV14	Touch drive signal output	
48	DRV13	Touch drive signal output	
49	DRV12	Touch drive signal output	
50	DRV11	Touch drive signal output	
51	DRV10	Touch drive signal output	
52	DRV09	Touch drive signal output	
53	DRV08	Touch drive signal output	
54	DRV07	Touch drive signal output	
55	DRV06	Touch drive signal output	

56	DRV05	Touch drive signal output	
57	DRV04	Touch driver signal output	
58	DRV03	Touch drive signal output	

5. Sensor Design

5.1. Sensing Channel Arrangement

SENS00~SENS28 are 29 capacitive detection input channels, which are directly connected to 29 sensing ITO channels of the touch panel module. The sensing ITO channels on the module are connected to SENS0 to SENS28 of the chip. After determining the layout, the relevant registers of the GT1151QM chip need to be configured to ensure the logical position relationship of each sensing channel is the same as the physical position relationship so that the output coordinates can match the physical coordinates.

5.2. Drive Channel Layout

DRV00~DRV15 are 16 capacitive detection drive signal output channels, which are directly connected to the 16 ITO drive channels of the touch panel module. After determining the layout, you need to configure the relevant registers of the GT1151QM chip to ensure that the logical position relationship of each drive channel is the same as the physical position relationship so that the output coordinates match the physical coordinates.

For more detailed rules on sensor design, please refer to the specific layout guide.

5.3. Sensor Design Parameters Requirements

DITO

	GT1151QM
Drive channel wiring impedance	$\cong 3K\Omega$
Drive channel wiring impedance	$\cong 10K\Omega$
Sensing channel wiring impedance	$\cong 10K\Omega$
Sending channel impedance	$\cong 40K\Omega$
Node capacitance	$\cong 4pF$

SITO

	GT1151QM
Drive channel wiring impedance	$\cong 3K\Omega$
Drive channel impedance	$\cong 10K\Omega$
Sensing channel wiring impedance	$\cong 10K\Omega$
Sensing channel impedance	$\cong 10K\Omega$
Node capacitance	$\cong 4pF$

When using metal wiring for channel routing, some of the wirings may become oxidized and cause an increase in impedance due to reasons such as process control, resulting in differences in the channel wiring. Although the ITO material wiring is used, efforts are made to ensure consistency of the channel wiring by matching the length and width during design, there may still be differences to some extent. To ensure consistency and uniformity of the entire screen data, it is necessary to control the wiring impedance to meet the requirements in the table. For details, please refer to the "Sensor Design Specification" of Goodix.

5.4. Touch Button Design

The GT1151QM supports 4 touch buttons, which can be implemented in two ways:

Sensor extension method: The sensing channel is used as the common end of the keypad, and one sensing channel and 4 drivers are used to form 4 keys. The sensing channel for the keypad cannot be multiplexed with the sensor on the screen, but the driver channel for the keypad must be multiplexed with the screen;

FPC design: one sensing channel and 4 drive channels are used to form 4 keys, and the 4 drive channels are partially multiplexed with the screen body. The sensor pattern of FPC needs to be specially designed.

6. I²C Communication

6.1 I²C Communication

GT1151QM provides a standard I2C communication interface, and SCL and SDA communicate with the main CPU. GT1151QM always acts as a slave device in the system, and its address is 0X28/0X29. All communication is initiated by the main CPU, and the recommended communication speed is 400Kbps or less. The timing of I2C hardware circuits supported by it is as follows:

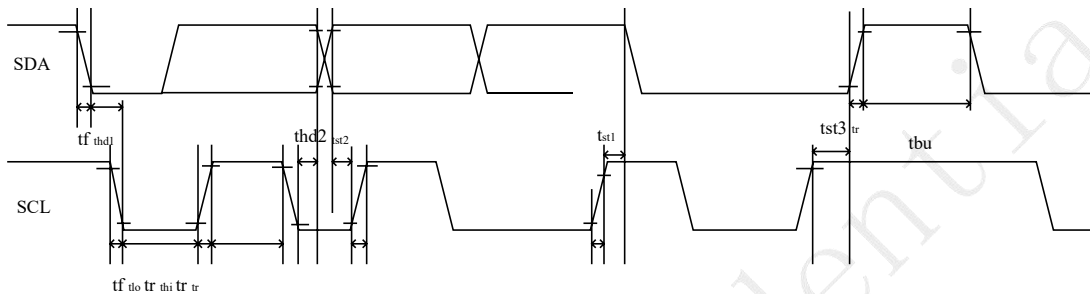

Test condition 1: 1.8V communication interface, 400Kbps, pull-up resistance 2K

Parameter	Symbol	Min.	Max.	Unit
SCL low period	t_{lo}	1.3	-	us
SCL high period	t_{hi}	0.6	-	us
SCL setup time for START condition	t_{st1}	0.6	-	us
SCL setup time for STOP condition	t_{st3}	0.6	-	us
SCL hold time for START condition	t_{hd1}	0.6	-	us
SDA setup time	t_{st2}	0.1	-	us
SDA hold time	t_{hd2}	0	-	us

Test condition 2: 3.3V communication interface, 400Kbps, pull-up resistance 2K

Parameter	Symbol	Min.	Max.	Unit
SCL low period	t_{lo}	1.3	-	us
SCL high period	t_{hi}	0.6	-	us
SCL setup time for START condition	t_{st1}	0.6	-	us
SCL setup time for STOP condition	t_{st3}	0.6	-	us
SCL hold time for START condition	t_{hd1}	0.6	-	us
SDA setup time	t_{st2}	0.1	-	us
SDA hold time	t_{hd2}	0	-	us

Power-up timing diagram:

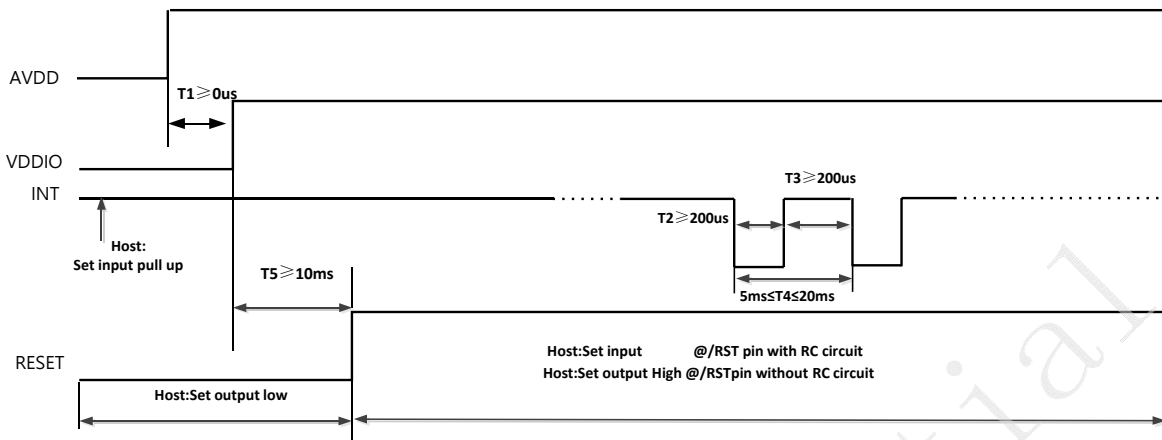

Host reset GT1151QM timing diagram

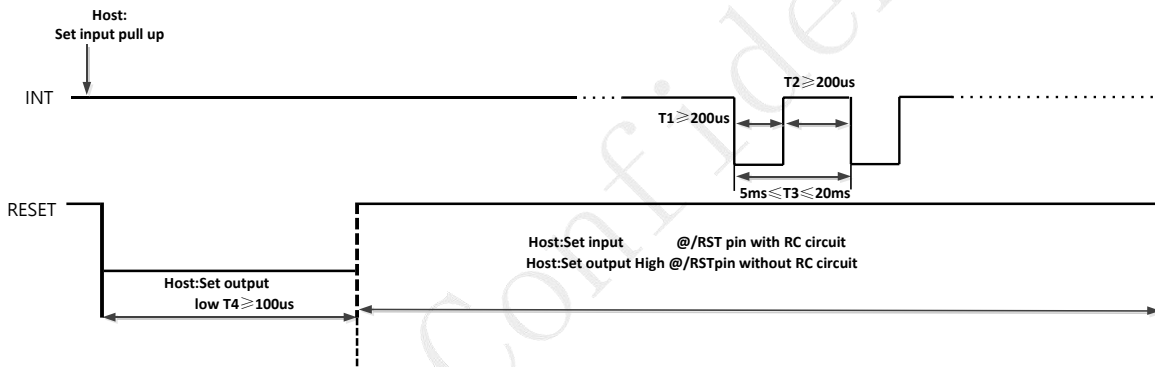

Host power down GT1151QM timing diagram

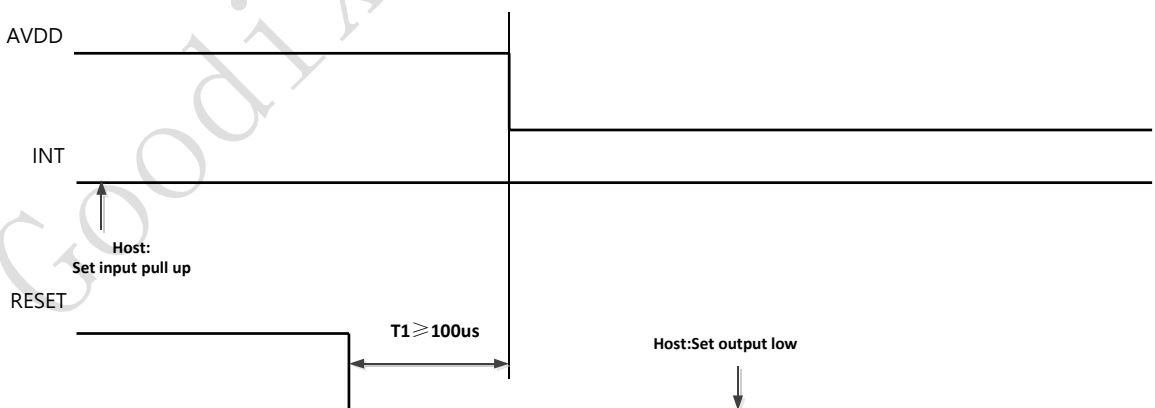

a) Data Transmission

Communication is always initiated by the main CPU, and the effective starting signal is: when SCL remains "1", the SDA jumps from "1" to "0". Address information or data stream is transmitted after the start signal.

All slave devices connected to the I2C bus should detect the 8-bit address information sent after the start signal on the bus and make a correct response. When receiving the address information that matches itself, GT1151QM changes SDA to output port and sets "0" as the response signal in the ninth clock cycle. If you receive address information that does not match you, that is, it is not 0X28 or 0X29, GT1151QM will remain idle.

The data on SDA port sends 9 bits of data in series according to 9 clock cycles: 8 bits of valid data plus 1 bit of acknowledgment signal ACK or non-acknowledgment signal NACK sent by the receiver. Data transmission is valid when SCL is "1".

When the communication is completed, the main CPU sends a stop signal. The stop signal is the transition of SDA state from "0" to "1" when SCL is "1".

b) Write Operation to GT1151QM

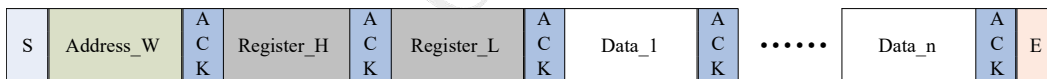

Write Operation Timing Diagram

The above diagram shows the flowchart of the write operation performed by the main CPU to the GT1151QM. First, the main CPU generates a start signal, then sends the address information and the read/write bit information "0" to indicate the write operation: 0X28.

After receiving the answer, the host CPU sends the 16-bit address of the register, followed by 8 bits of data to be written to the register.

The address pointer of the GT1151QM register is automatically added by 1 after the

write operation, so when the host CPU needs to write to a register with consecutive addresses, it can write continuously in a single write operation. When the write operation is completed, the host CPU sends a stop signal to end the current write operation.

c) Read Operation to GT1151QM

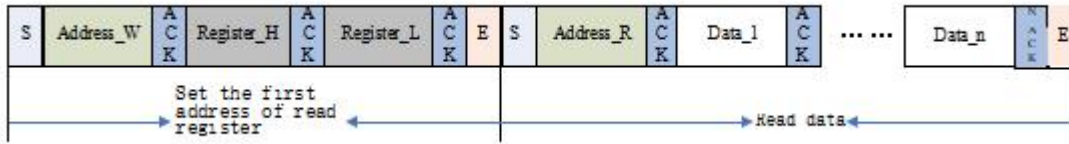

Read Operation Timing Diagram

The above diagram shows the flow chart of the read operation performed by the main CPU on the GT1151QM. First, the main CPU generates a start signal, then sends the device address information and the read/write bit information "0" to indicate the write operation: 0X28.

After receiving the answer, the main CPU sends the 16-bit address information of the first register to set the address of the register to be read. After receiving the answer, the main CPU sends the start signal again to send the read operation: 0X29. After receiving the answer, the main CPU starts to read the data.

GT1151QM also supports continuous read operation, and the default is to read data continuously. The main CPU needs to send an answer signal after each Byte of data received to indicate successful reception. After receiving the last Byte data required, the main CPU sends a "no-response signal NACK" and then sends a stop signal to end the communication.



7. Function Description

7.1. Working mode

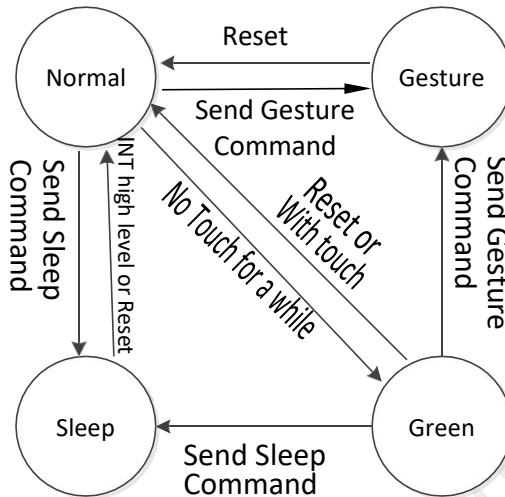

a) Normal Mode

When GT1151QM is in Normal mode, the coordinate refresh period is between 5 ms and 20 ms (depending on the setting of configuration information, the controllable periodic stepping length of configuration information is 1 ms).

b) Green Mode

In the Normal mode state, there is no touch event for a period of time, and the GT1151QM will automatically switch to the Green mode to reduce power consumption. The time for GT1151QM to automatically enter the Green mode without touching can be set through configuration information, ranging from 0 to 14s, and the stepping is 1s, and the Green mode can be turned off. In Green mode, the scanning period of GT1151QM is about 40ms, and if touch action is detected, it will automatically enter Normal mode.

c) Gesture Mode

If the main CPU passes the I2C command, GT1151QM can wake up by sliding the screen, double-clicking, or writing specific characters on the screen after entering the Gesture mode.

In Gesture mode, GT1151QM detects that the finger slides on the screen for a sufficient length, the double-click action, and the book.

When writing a specific character or writing a custom character, INT will output a pulse of more than 250us (configurable) or keep it high all the time. After receiving the pulse, the master wakes up and lights up the screen.

d) Sleep Mode

The main CPU makes GT1151QM enter Sleep mode through the I2C command. When the GT1151QM needs to exit the Sleep mode, the host performs a reset operation on the GT1151QM. GT1151QM will enter Normal mode after reset. The time interval between issuing the command and resetting is required to be greater than 58 ms.

7.2. Sensitivity State Switching

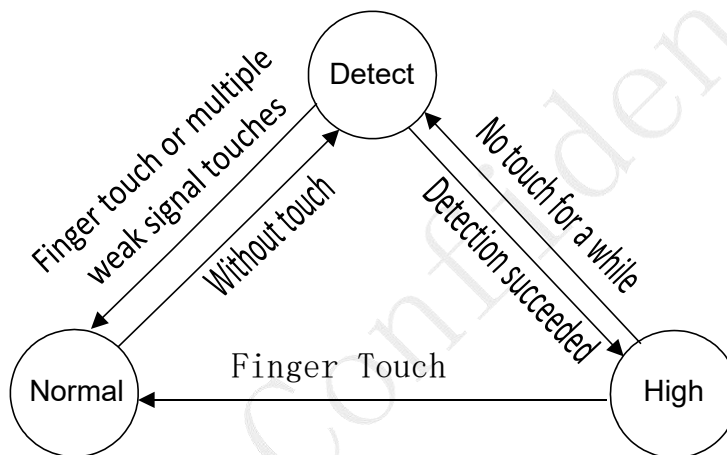

a) Normal State (Normal Sensitivity)

In the Normal state, a higher touch threshold is used to identify the touch signal to locate the touch position, so as to reduce the interference of noise. In this state, only a finger touch is supported.

b) High State (High Sensitivity)

In the High state. Use a low touch threshold to identify the touch signal to locate the touch position, which supports the touch of gloves and pens. In this state, once a finger

touch is detected, it returns to the Normal state.

c) Detect State

If there is no touch in the Normal state or no touch in the High state for a period of time, GT1151QM will automatically switch to Detect.

status When finger touch or multiple weak signal touches are Detected in the detect state, it will switch to the Normal state;

In the Detect state, it is detected that a single weak signal slides or clicks twice in a row, and then it enters the High state. In the Detect state, coordinate reporting is not performed.

d) Glove Material

Because there are all kinds of gloves on the market from different materials to different thicknesses. Because of the great difference, here is an adaptive explanation for the material and thickness of gloves. From the surface material of gloves, metal and leather have better effects, followed by wool, nylon and cotton. In terms of thickness, the thickness supported by metal and leather is larger, while the thickness supported by wool, nylon and cotton is thinner.

7.3. Interrupt Trigger Mode

When there is touch, GT1151QM will send out a falling edge pulse signal via the INT pin every scanning cycle to inform the main CPU to read the coordinate information.

7.4. Fixed Configuration Function

GT1151QM supports fixed configuration function, and can save a set of fixed parameters in chip Flash. The GT1151QM after saving the curing type parameters will only communicate with the master controller through I²C, and will not receive the configuration of the non-fixed type issued by the master controller.

7.5. Frequency Hopping Function

GT1151QM has a good hardware anti-jamming foundation. When the driving spectrum of GT1151QM overlaps with the peak spectrum of the interference signal, it can switch to another frequency through an adaptive frequency hopping mechanism to avoid interference.

7.6. Self-calibration

a) Initialization Calibration

Different temperatures, humidity, and physical space structure will affect the reference value of the capacitance sensor in an idle state. GT1151QM will automatically obtain a new detection benchmark according to environmental conditions within 200ms of initialization. Complete the initialization of touch screen detection.

b) Automatic Temperature Drift Compensation

Slow changes in environmental factors such as temperature, humidity or dust can also affect the reference value of the capacitive sensor in the idle state. The GT1151QM detects changes in data at each point in real time, and performs statistical analysis of historical data, thereby correcting the detection reference. This reduces the impact of environmental changes on touch screen detection.

Goodix Confidential

8. Reference Circuit Diagram

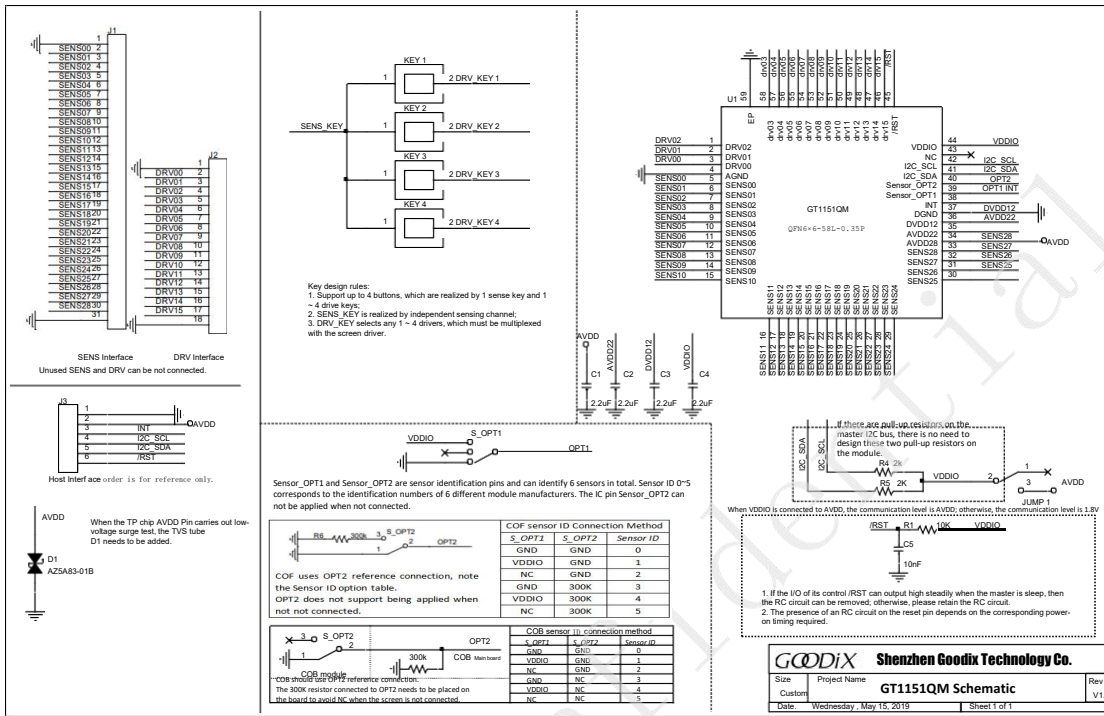

GT1151QM Reference Application Circuit Diagram

Note:

1. This circuit represents only the basic application method. In actual use or according to specific application requirements, some parts of the circuit may need to be adjusted.
2. X5R or X7R materials are recommended for capacitors.

9. Electrical Specification

9.1. Ultimate Electrical Parameters

Specifications	Min.	Max.	Unit
Analog power supply AVDD28 (refer to GND)	-0.3	4.2	V
Analog power supply AVDD22 (refer to GND)	-0.3	4.2	V
Digital power supply DVDD12 (refer to GND)	-0.3	4.2	V
VDDIO (reference GND)	-0.3	4.2	V
Digital I/O can withstand voltage	-0.3	4.2	V
Analog I/O withstand voltage	-0.3	4.2	V
Storage temperature range	-60	125	°C
Welding temperature (10 seconds)	-	260	°C
ESD protection voltage (HB Model)	±4		KV

9.2. Recommended Working Conditions

(Ambient temperature is 25°C)

Specifications	Min.	Typ.	Max.	Unit
AVDD28 ^①	2.7	2.8/3.0/3.3	3.4	V
AVDD22	-2.2	2.2	-V	V
DVDD12	-V	1.2	-V	V
VDDIO ^②	-VDDIO	1.8	-	V
Operating temperature range	-20	25	85	°C

9.3. AC Characteristics

(Ambient temperature is 25°C, AVDD28=2.8V, VDDIO=1.8V)

Specifications	Min.	Typ.	Max.	Unit
OSC Oscillation frequency	63.36	64.0	64.64	MHz
I/O Output Low to High Conversion Time		15@100pF		ns
I/O Output High to Low		12.5@100p		ns

Conversion Time		F		
-----------------	--	---	--	--

① AVDD28 supply voltage (typical value) ripple requirement: $V_{pp} \leq 100\text{mV}$, (minimum, maximum) ripple requirement: $V_{pp} \leq 50\text{mV}$.

② The level of VDDIO is 1.8V when VDDIO is suspended; when VDDIO is connected to AVDD28, the level of VDDIO is AVDD28.

9.4. DC Characteristics

(Ambient temperature is $-20^{\circ}\text{C} \sim 70^{\circ}\text{C}$, AVDD28=2.8V, VDDIO=1.8V or VDDIO=AVDD28.)

Specifications	Min.	Typ.	Max.	Unit
Normal mode peak current @120Hz	-	44	50	mA
Normal mode working current @120Hz	-	32	-	mA
Green mode working current@32ms ^③	-	3	-	mA
Gesture mode working current ^④	-	0.8	-	mA
Sleep mode working current	-	100	-	uA
Digital input is low voltage value /VIL	-0.3		$0.25 * V_{DDIO}$	V
Digital input is a high voltage value /VIH	$0.75 * V_{DDIO}$		$V_{DDIO} + 0.3$	V
Digital output is low voltage value /VOL			$0.15 * V_{DDIO}$	V
Digital output is high voltage value /VOH	$0.85 * V_{DDIO}$			V

Note: The actual current value in each mode will be different according to the number of channels and firmware configuration.

According to the actual verification results, the change of peak current is less than 0.5mA after IC is made into a module.

③ 32ms indicates the scanning period in Green mode.

④ The working current of Gesture Mode is the current under the condition of No Touch.

10. Product Packaging

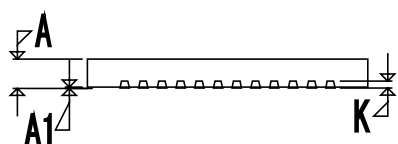
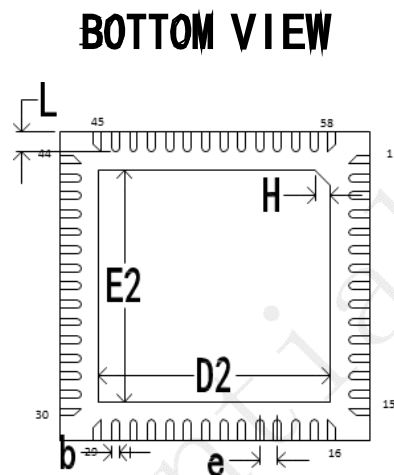
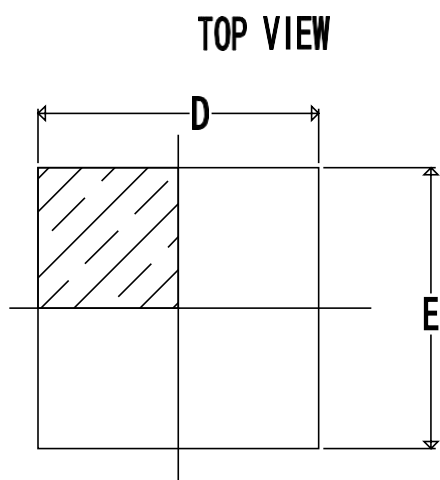

SIDE VIEW

QFN 6 X 6 58PIN

0.35 PITCH SQUARE

Symbol	Dimensions In Millimeters		
	Min.	Normal	Max.
A	0.5	0.55	0.60
A1	0.00	0.035	0.05
b	0.10	0.15	0.20
D	5.90	6.00	6.10
E	5.90	6.00	6.10
D2	4.40	4.50	4.60
E2	4.40	4.50	4.60
e	0.35BSC		
H	0.30REF		
K	0.152REF		
L	0.35	0.40	0.45

11. SMT Reflow Soldering Requirements

11.1. Humidity Sensitive Level

GT1151QM has a moisture sensitivity level of 3, with the following requirements:

- 1) Effective storage time in vacuum packaging: 12 months under normal electronic component storage conditions; storage environment conditions: temperature $<40^{\circ}\text{C}$, relative humidity $<90\%$ R.H
- 2) After the vacuum package is opened, if the device is used for infrared reflow equipment or equivalent processing (temperature not exceeding 260°C), the following conditions must be met.
 - a) Online production within 168 hours (factory environment $\leq 30^{\circ}\text{C}/60\%$ R.H.)
 - b) Stored under $\leq 10\%$ R.H. conditions (e.g., in a dry cabinet)
- 3) The device needs to be dried before going into production under the following conditions:
 - a) Humidity indicator card shows $>20\%$ at $23\pm 5^{\circ}\text{C}$.
 - b) Does not conform to 2a or 2b
- 4) If the device needs to be dried, the drying time is
 - a) For low-temperature devices in sealed packaging (e.g., products in reel packaging), dry for 192 hours under conditions of $40^{\circ}\text{C}+5^{\circ}\text{C}/-0^{\circ}\text{C}$ and $<5\%$ R.H.
 - b) For high-temperature devices in sealed packaging (e.g., products in tray packaging), dry for 24 hours at $125^{\circ}\text{C}+5^{\circ}\text{C}/-0^{\circ}\text{C}$.
 - c) After baking, it should be put into a vacuum bag immediately after cooling. Pack the tape in a vacuum bag, put in not less than 5g desiccant and a 6-dot humidity indicator card, and vacuumize and seal for storage; Pack the tray in a vacuum bag, put in not less than 10g desiccant and a 6-dot humidity indicator card, and vacuum and seal for storage.

11.2. Reflow Soldering Times

Reflow soldering times ≤ 3 times.

11.3. Lead-free Reflow Curve Diagram

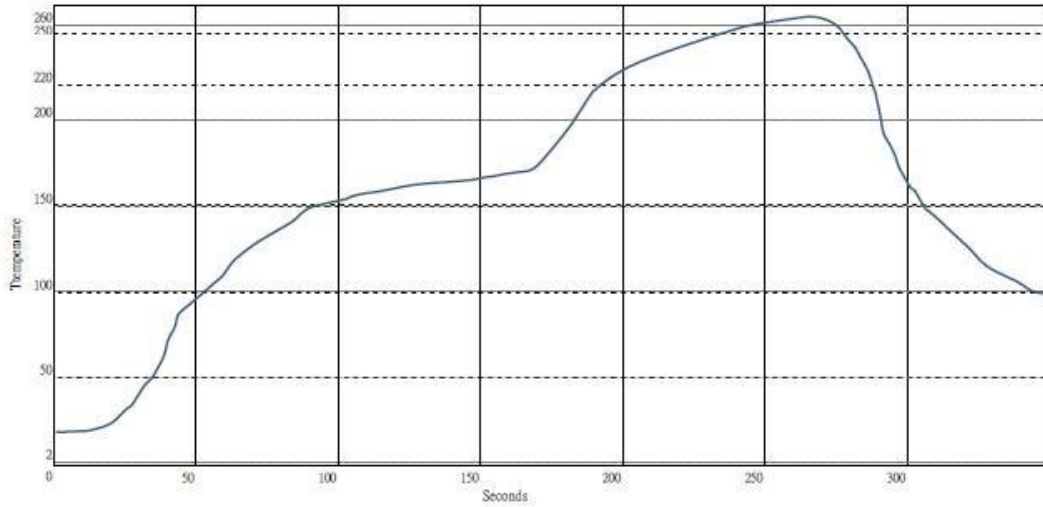

According to J-STD-020D-01, the Pb-Free reflow temperature curve of GT1151QM chip is described in the following table.

Interval		Lead-free process time parameters (reference)			
Normal temperature to peak temperature stage	A preheating zone (25°C~150°C)	Holding time	80s ~120s		
		Rising slope	<3°C/s		
	B constant temperature zone (150°C~200°C)	Holding time	60s~120s (Recommended: 100s)		
		Rising slope	<1°C/s		
	Up to 217°C	C 217°C~260°C	Holding time	60s ~85s	Recommended holding time above 217°C is between 60s and 150s.
			Rising slope	<3°C/s	
E 260°C~217°C	D 255°C~260°C	Holding time	20s ~30s		
		Cooling slope	<6		
--					

The time for temperature stage from room temperature to peak should not exceed 8 minutes.

			°C/ s	
--	Cooling zone below F217°C	Cooling slope	1°C/s~3°C/ s	--

Note: Please follow the J-STD-020D-01 standard.

12. Version Record

Document version	Revision time	Revision
V0.1	2019-05-15	Pre-release

Goodix Confidential

13. Contact



Shenzhen Goodix Technology Co., Ltd

Floor 13, Phase B, TengFei Industrial Building, FuTian Free Trade Zone, ShenZhen,
518000

TEL: +86-755-33338828 FAX: +86-755-33338828

www.goodix.com

Goodix Confide