

YGMOS Technology Crop.

30V P-Channel Enhancement-Mode MOSFET 30V P 沟道增强型 MOS 管

 $V_{DS} = -30V$
 $R_{DS(ON)}, V_{GS} @ -10V, I_{DS} @ -4.2A = 60m\Omega$
 $R_{DS(ON)}, V_{GS} @ -4.5V, I_{DS} @ -4.0A = 75m\Omega$
 $R_{DS(ON)}, V_{GS} @ -2.5V, I_{DS} @ -1.0A = 120m\Omega$

台湾原厂MOS 联系人:肖生 手机:13145858210 电话:0755-83742865 QQ:582242920

Features 特性

Advanced trench process technology 高级的加工技术

High Density Cell Design For Ultra Low On-Resistance 极低的导通电阻高密度的单元设计

Package Dimensions 封装尺寸及外形图

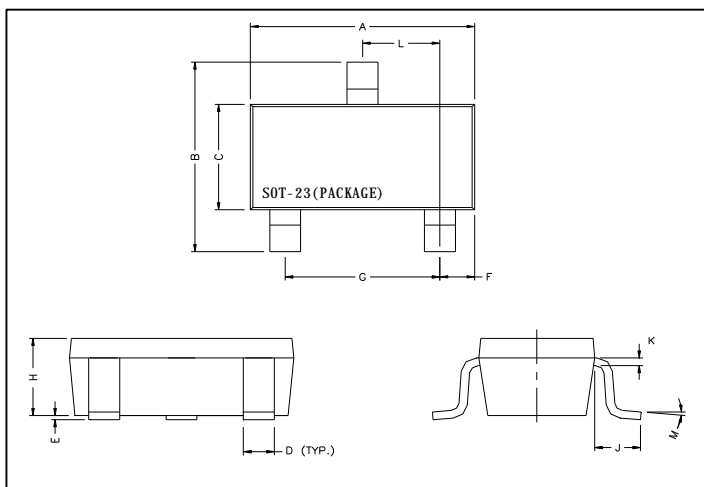

Marking

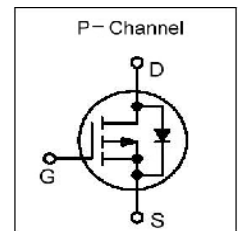
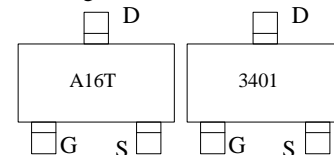

REF.	Millimeter		REF.	Millimeter	
	Min.	Max.		Min.	Max.
A	2.70	3.10	G	1.90	REF.
B	2.40	2.80	H	1.00	1.30
C	1.40	1.60	K	0.10	0.20
D	0.35	0.50	J	0.40	-
E	0	0.10	L	0.85	1.15
F	0.45	0.55	M	0°	10°

Maximum Ratings and Thermal Characteristics (TA = 25°C unless otherwise noted) 25°C 极限参数和热特性

Parameter 极限参数	Symbol 符号	Limit 范围	Unit 单位	
Drain-Source Voltage 漏源电压	V_{DS}	-30	V	
Gate-Source Voltage 栅源电压	V_{GS}	±12		
Continuous Drain Current 连续漏极电流	I_D	-4.2	A	
Pulsed Drain Current 脉冲漏极电流	I_{DM}	-30		
Maximum Power Dissipation 最大耗散功率	P_D	TA = 25°C	1.4	W
		TA = 75°C	1	
Operating Junction and Storage Temperature Range 使用及储存温度	T_J, T_{stg}	-55 to 150	°C	
Junction-to-Ambient Thermal Resistance (PCB mounted) 结环热阻	$R_{\theta JA}$	125	°C/W	

YGMOS Technology Crop.
ELECTRICAL CHARACTERISTICS 一般电气特性

Parameter 参数	符号	Test Condition 测试条件	最小值	典型值	最大值	单位
Static 静态参数						
Drain-Source Breakdown Voltage 漏源击穿电压	BV_{DSS}	$V_{GS} = 0V, I_D = -250\mu A$	-30			V
Drain-Source On-State Resistance 漏源导通电阻	$R_{DS(on)}$	$V_{GS} = -10V, I_D = -4.2A$		53.0	60.0	mΩ
Drain-Source On-State Resistance 漏源导通电阻	$R_{DS(on)}$	$V_{GS} = -4.5V, I_D = -4A$		64.0	75.0	
Drain-Source On-State Resistance 漏源导通电阻	$R_{DS(on)}$	$V_{GS} = -2.5V, I_D = -1A$		86.0	120.0	
Gate Threshold Voltage 开启电压	$V_{GS(th)}$	$V_{DS} = V_{GS}, I_D = -250\mu A$	-0.7	-1	-1.3	V
Zero Gate Voltage Drain Current 零栅压漏极电流	I_{DSS}	$V_{DS} = -24V, V_{GS} = 0V$			-1	μA
Gate Body Leakage 漏极短路时截止栅电流	I_{GSS}	$V_{GS} = \pm 12V, V_{DS} = 0V$			± 100	nA
Forward Transconductance 正向跨导	g_{fs}	$V_{DS} = -5V, I_D = -5A$	7	11	—	S
Dynamic 动态参数						
Total Gate Charge 栅极总电荷	Q_g	$V_{DS} = -20V, I_D = -5.7A$ $V_{GS} = -10V$		9.4		nC
Gate-Source Charge 栅-源极电荷	Q_{gs}			2		
Gate-Drain Charge 栅-漏极电荷	Q_{gd}			3		
Turn-On Delay Time 导通延迟时间	$t_{d(on)}$	$V_{DD} = -20V, R_L = 20\Omega$ $I_D = -1A, V_{GEN} = -10V$ $R_G = 6\Omega$		6.3		ns
Turn-On Rise Time 导通上升时间	t_r			3.2		
Turn-Off Delay Time 关断延迟时间	$t_{d(off)}$			38.2		
Turn-Off Fall Time 关断下降时间	t_f			12		
Input Capacitance 输入电容	C_{iss}	$V_{DS} = 8V, V_{GS} = 0V$ $f = 1.0\text{ MHz}$		954		pF
Output Capacitance 输出电容	C_{oss}			115		
Reverse Transfer Capacitance 反向传输电容	C_{rss}			77		
Source-Drain Diode 源漏二极管参数						
Max. Diode Forward Current 最大正向电流	I_S				-2.2	A
Diode Forward Voltage 正向电压	V_{SD}	$I_S = 1.8A, V_{GS} = 0V$			-1.0	V

Note: Pulse test: pulse width $\leq 300\mu s$, duty cycle $\leq 2\%$ 注意: 脉冲测试: 脉冲宽度 $\leq 300\mu s$ 死区 $\leq 2\%$

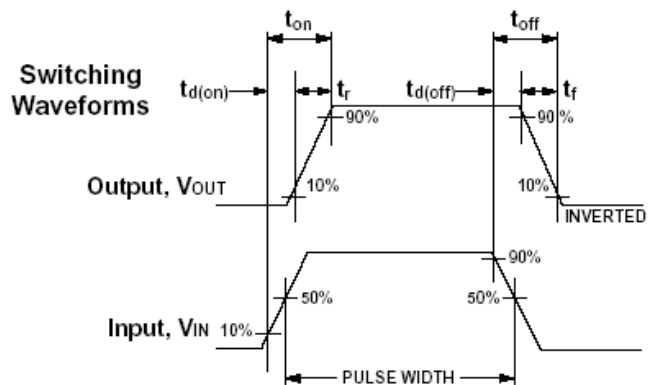
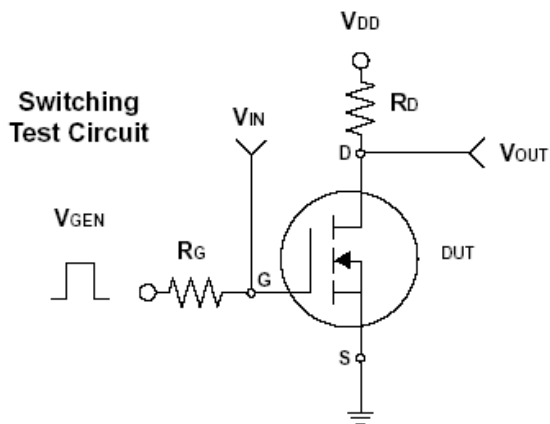

YGMOS Technology Corp.
P-Channel Enhancement Mode Mosfet
Typical Characteristics (T_J = 25°C Noted)
