



GT34TS02B

GT34TS02B

Temperature Sensor

With 2K Bits

SPD EEPROM

Copyright © 2013 Giantec Semiconductor Inc. (Giantec). All rights reserved. Giantec reserves the right to make changes to this specification and its products at any time without notice. Giantec products are not designed, intended, authorized or warranted for use as components in systems or equipment intended for critical medical or surgical equipment, aerospace or military, or other applications planned to support or sustain life. It is the customer's obligation to optimize the design in their own products for the best performance and optimization on the functionality and etc. Giantec assumes no liability arising out of the application or use of any information, products or services described herein. Customers are advised to obtain the latest version of this device specification before relying on any published information and prior placing orders for products.



GT34TS02B

Table of Contents

1. Features	4
1.1 The 2Kb SPD EEPROM Features	4
1.2 Temperature Sensor Features	4
2. General Description	5
2.1 2K-bit SPD EEPROM	5
2.2 Temperature Sensor	5
3. Functional Block Diagram	6
4. Pin Configuration	7
4.1 8-Lead UDFN	7
4.2 Pin Definition	7
4.3 Pin Descriptions	7
5. I²C / SMBus Serial Interface	8
5.1 Serial bus interface	8
5.2 I ² C / SMBus Communication	8
5.3 Start Condition	8
5.4 Stop Condition	8
5.5 Acknowledge	8
5.6 Slave address	8
5.7 Power-Up and Reset States	9
6. Temperature Sensor	12
6.1 TS Register Overview	12
6.2 Pointer Register	12
6.3 Capability Register	13
6.4 Configuration Register	14
6.5 Upper Alarm Window Register	17
6.6 Lower Alarm Window Register	17
6.7 Critical Alarm Register	17
6.8 Temperature Register	17
6.9 Manufacturer's ID Register	19
6.10 Device ID Register	19
6.11 SMBus Timeout Register	19
6.12 Temperature Resolution Register	19
6.13 EVENT output	20
6.14 Alarm window	20
7. EEPROM Functional Description	21
7.1 Read and Write Operation	21
7.2 Write Protection	23
7.3 Reading Write Protection Status	23
8. Electrical Characteristics	26
8.1 Absolute Maximum Ratings	26
8.2 Operating Range	26
8.3 Capacitance	26
8.4 DC Electrical Characteristic	27



GT34TS02B

8.5 AC Electrical Characteristic	28
9. Ordering Information	29
10. Top Markings	30
10.1 UDFN Package	30
11. Package Information	31
11.1 UDFN	31
12. Revision History	32



GT34TS02B

1. Features

- Supply voltage: Supply voltage: 1.7V to 3.6V (SPD EEPROM) and 2.2V to 3.6V (TS)
 - 500 μ A (max) TS being active and EEPROM in Standby mode
 - 2 mA (max) TS in Shutdown and EEPROM are active
- JEDEC TSE2002av Compliant Temperature Sensor
- 2-wire serial interface I²C/SMBus compatible
- Low operating current
 - 5 μ A (max) TS in Shutdown mode and EEPROM in Standby mode
- Software Programmable Shutdown Mode
- Software reset feature
- Speed up to 400 kHz

1.1 The 2Kb SPD EEPROM Features

- Functionality identical to GT34C02 device
- Byte and Page Write Operations
 - Page Size up to 16 bytes
- Random and Sequential Read modes
- Self-Time Write Cycle (5ms, max)
- Automatic Address Incrementing
- Permanent and Reversible Software data Protection for the lower 128 bytes
- Noise filter on bus inputs
- More than 1 million Erase/Write Endurance Cycles
- More than 40 years Data Retention
- Operating Temperature range: -40°C to + 125°C

1.2 Temperature Sensor Features

- Temperature sensor accuracy (Grade B):
 - $\pm 1^{\circ}$ C from +70°C to +95°C
 - $\pm 2^{\circ}$ C from +40°C to +125°C
 - $\pm 3^{\circ}$ C from -40°C to +125°C
- Temperature sensor resolution: 0.0625°C/LSB
- The TS continuously monitors the temperature and updates the temperature data typically ten times per second. Temperature data is latched internally by the device and may be read by software from the bus host at any time.
- Temperature sampling (ADC conversion) time: 125 msec (max.)
- Hysteresis selectable set points from: 0, 1.5°C, 3°C & 6°C
- Ambient temperature sensing range: -40°C to +125°C



GT34TS02B

2. General Description

The GT34TS02B is a Temperature Sensor (TS) product with embedded 2K-bit Serial Presence Detect (SPD) EEPROM, which is fully compatible to industrial standard I²C/SMBus interface and compliant to the JEDEC 42.4 specification. The EEPROM memory is organized as 256 x 8 bits and is functionally identical to the GT34C02. This product is designed for memory module applications in

2.1 2K-bit SPD EEPROM

The embedded 2K-bit serial SPD EEPROM has the functions identical to the GT34C02. One of the features is to permanently lock the data in its first half (lower) 128 bytes (address 00h to 7Fh). This feature is specifically designed for use in DRAM DIMM with SPD. All information concerning the DRAM module configuration (e.g. access speed, size, and organization) can be kept write-protected

2.2 Temperature Sensor

The TS monitors the ambient temperature ranging from -40°C to 125°C. The TS includes a high precision CMOS temperature sensor, a sigma-delta analog to digital converter (ADC) and a serial interface compatible to industrial standard I²C/SMBus. The ADC default resolution is set at 10-bit (0.25°C). The accuracy over various temperature ranges is:

- ±1°C (max) for temperature range from +70°C to +95°C
- ±2°C (max) for temperature range from +40°C to +125°
- ±3°C (max) for temperature range from -40°C to 125°C

most PC and Server platforms, as well as other related applications.

The unique GT34TS02B product operates from 1.7V to 3.6V and is offered in 8-pin Ultra-thin DFN package, 2 mm x 3 mm x 0.6 mm (max.), which is lead-free, RoHS, halogen free or Green compliance, providing space as well as cost saving for DIMM manufactures.

in the first half of the memory. The second half (upper) 128 bytes of the memory (address 80h to FFh) can't be write-protected using two different software write protection mechanisms. By sending a specified sequence to the device, the first 128 bytes memory can be write-protected either permanently or resettable. The operating ambient temperature ranging is from -40°C to +85°C.

The TS has shutdown current 5 μA (max.) with SPD EE in Standby mode.

The TS component has user-programmable registers that provide the capabilities for DIMM temperature-sensing applications. The open drain **EVENT** output pin is active when the monitoring temperature exceeds a programmable limit, or falls below or rises above an alarm window. The user has the option to set the **EVENT** output as a critical temperature output. This output can be configured to operate in either a comparator mode for thermostat operation or in interrupt mode.



GT34TS02B

3. Functional Block Diagram

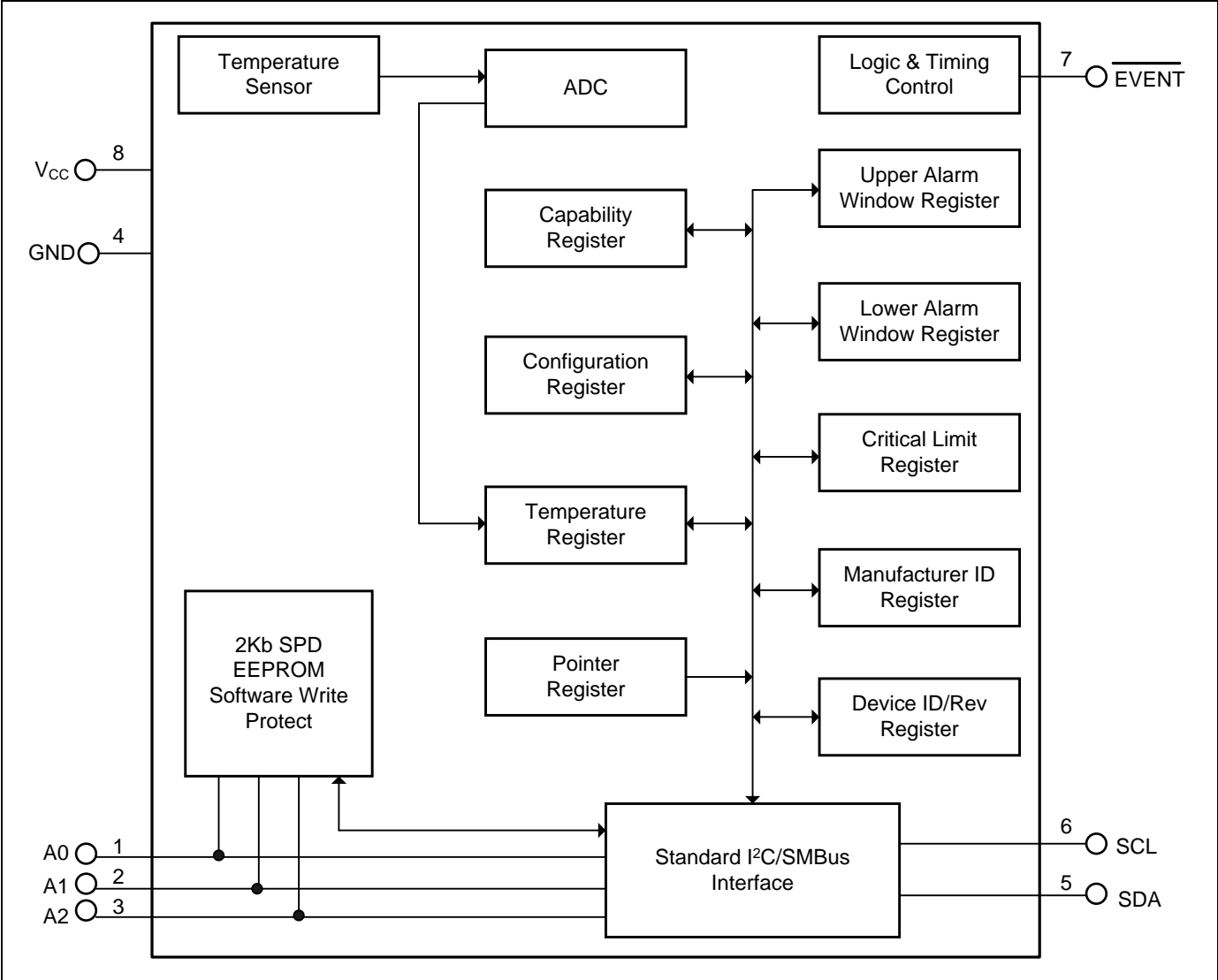



GT34TS02B

4. Pin Configuration

4.1 8-Lead UDFN

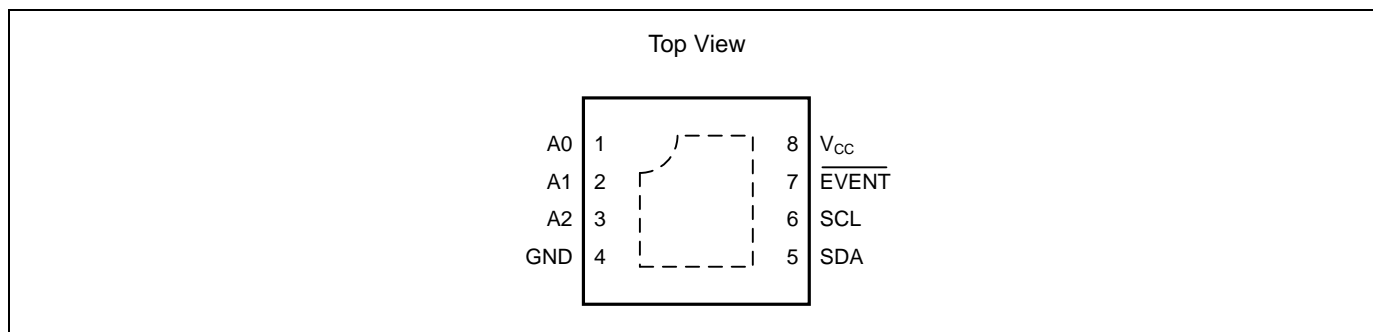

4.2 Pin Definition

Pin No.	Pin Name	I/O	Definition
1	A0	I	Device Address Input
2	A1	I	Device Address Input
3	A2	I	Device Address Input
4	GND	-	Ground
5	SDA	I/O	Serial Address, Data input and Data output (Open drain)
6	SCL	I	Serial Clock Input
7	$\overline{\text{EVENT}}$	O	$\overline{\text{EVENT}}$ pin (open drain and active-low) ^[1]
8	V _{CC}	-	Power Supply

Note: ^[1] When active, functions as an Alert interrupt.

4.3 Pin Descriptions

SCL

This input clock pin is used to synchronize the data transfer to and from the device.

SDA

The SDA is a bi-directional pin used to transfer addresses and data into and out of the device. The SDA pin is an open drain output and can be wired with other open drain or open collector outputs. However, the SDA pin requires a pull-up resistor connected to the power supply.

A0, A1, A2

The A0, A1 and A2 are the device address inputs.

Typically, the A0, A1, and A2 pins are for hardware

addressing and a total of 8 devices can be connected on a single bus system. When A0, A1, and A2 are left floating, the inputs are defaulted to zero.

$\overline{\text{EVENT}}$

The $\overline{\text{EVENT}}$ pin is an open-drain pin that can be defined by the configuration register. The $\overline{\text{EVENT}}$ output reacts to temperature changes as illustrated in Figure 6-2

V_{CC}

Supply voltage

GND

Ground of supply voltage



GT34TS02B

5. I²C / SMBus Serial Interface

5.1 Serial bus interface

The GT34TS02B utilizes the industrial standard 2-wire bus supporting either I²C or SMBus protocol to communicate with a master controller. The master generates the SCL signal and GT34TS02B being a slave device utilizes the SCL signal to receive or send data via the SDA line. Data transfer is serial, bi-directional, and is one bit at a time with the Most Significant Bit (MSB) transferred first, and a complete I²C bus data is 1-byte. Since SDA and **EVENT** are open-drain, pull-up resistors are required.

5.2 I²C / SMBus Communication

This protocol provides the communications to

- The registers selected by the Pointer register.
- At power-up, the Pointer register is set to “00”, i.e. the Capability register location.
- The Pointer register latches the last location being set to. Also, pending upon the selected bits [P2:P0] of pointer register, each data registers falls into one of two types of user accessibility:
 - Read only
 - Write / Read
- A Write to GT34TS02B will always include the address byte and the pointer byte. A Write to any register other than the pointer register, requires two data bytes.
- A Read operation can be performed in either
 - If the location latched in the Pointer register is correct (most of the time it is expected that the Pointer register will point to one of the Read Temperature registers because that will be the data most frequently read), then the Read can simply consist of an address byte, followed by retrieval of the two data bytes, OR
 - If the Pointer register needs to be set, then an address byte, pointer byte, repeat start, and another address byte will accomplish a Read
- The data byte communication transfers the MSB (Bit 7) first.
- At the end of a Read, GT34TS02B can accept either

an Acknowledge (ACK) or No Acknowledge (No ACK) status from the Master. The No ACK status is typically used as a signal for the slave that the Master has read its last byte. This device subsequently takes up to 125ms to measure the temperature.

- For the SMBus communication, conditions of 10KHz minimum clock frequency, 300ns data hold time and 50ms maximum time-out (TS only) are required.

5.3 Start Condition

The Start condition precedes all commands to the device and is defined as a High to Low transition of SDA when SCL is High. The EEPROM monitors the SDA and SCL lines and will not respond until the Start condition is met.

5.4 Stop Condition

The Stop condition is defined as a Low to High transition of SDA when SCL is High. All operations must end with a Stop condition.

5.5 Acknowledge

After a successful data transfer, each receiving device is required to generate an ACK. The Acknowledging device pulls down the SDA line.

5.6 Slave address

GT34TS02B uses 7-bit slave address, which consists of 4 fixed bits (Device Type Identifier, D0~D3) and 3 programmable bits (A0, A1 and A2), allowing a total of eight devices to co-exist on the same bus. The input of each pin is sampled at the start of each I²C/SMBus access.

The TS and EEPROM in GT34TS02B each have its own unique I²C address for the 4 bits Device Type Identifier (DTI), which are the first 4 bits of the Slave address:

- 0011: TS
- 1010 : EE
- 0110: Access software write protection operations on the EEPROM

The rest of 3 bits, A2, A1 and A0, are configurable to select one of eight possible Slave devices.

The last bit, R/\overline{W} , specifies whether a Read (1) or Write (0) operation is being performed.



GT34TS02B

Table 5.1 Device Address Format

Memory Area Function	Slave Address							R/ \bar{W} #
	Device Type Identifier				Select Address Signals			
	D3	D2	D1	D0	A2	A1	A0	
Read/Write TS Register	0	0	1	1	A2	A1	A0	R/ \bar{W} #
Read/Write EEPROM Memory	1	0	1	0	A2	A1	A0	R/ \bar{W} #
Set Write Protection (SWP)	0	1	1	0	0	0	1	0
Clear Write Protection (CWP)					0	1	1	0
Permanently Set Write Protection (PSWP)					A2	A1	A0	0
Read SWP					0	0	1	1
Read CWP					0	1	1	1
Read PSWP					A2	A1	A0	1

Note: D3 (MSB), R/ \bar{W} # (LSB)

5.7 Power-Up and Reset States

5.7.1 Power-Up Condition

After power-on, GT34TS02B is initialized to the following default condition:

- Pointer register is defaulted to 00h
- Starts monitoring local sensor
- $\overline{\text{EVENT}}$ register is cleared: $\overline{\text{EVENT}}$ output is pulled high by external pull-up resistor.
- $\overline{\text{EVENT}}$ hysteresis is defaulted to 0°C
- Critical temperature, Alarm Temperature Upper and Lower register are defaulted to 0°C
- Capability register is defaulted to 000Fh
- Operational mode: comparator

After supply voltage reaches to a stable minimum level, TS needs a minimum of 250 msec prior to perform an

appropriate measurement.

The device incorporates a power on reset circuit, which protects the internal logic against powering up into a wrong state. Nevertheless, the following conditions on power supply are recommended in the Figure 5.1.

5.7.2 Software Reset

The device contains a reset function in case the 2-wire bus transmission on is accidentally interrupted (e.g. a power loss), or needs to be terminated mid-stream. The reset is initiated when the Master device creates a Start condition. To do this, it may be necessary for the Master device to monitor the SDA line while cycling the SCL up to nine times. (For each clock signal transition to High, the Master checks for a High level on SDA.)

Figure 5.1 POR Condition

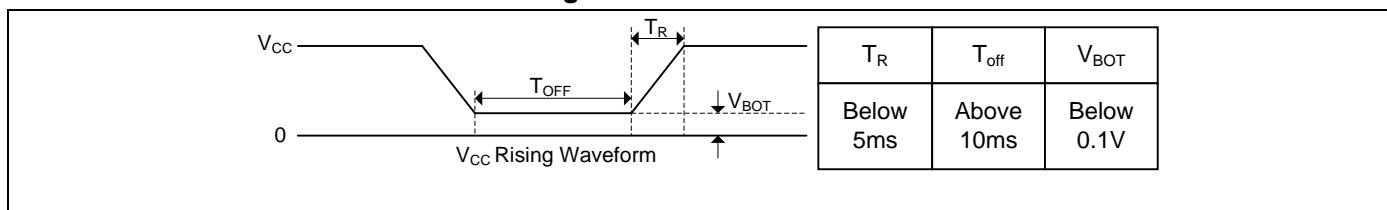



GT34TS02B

Figure 5-2. Typical System Bus Configuration

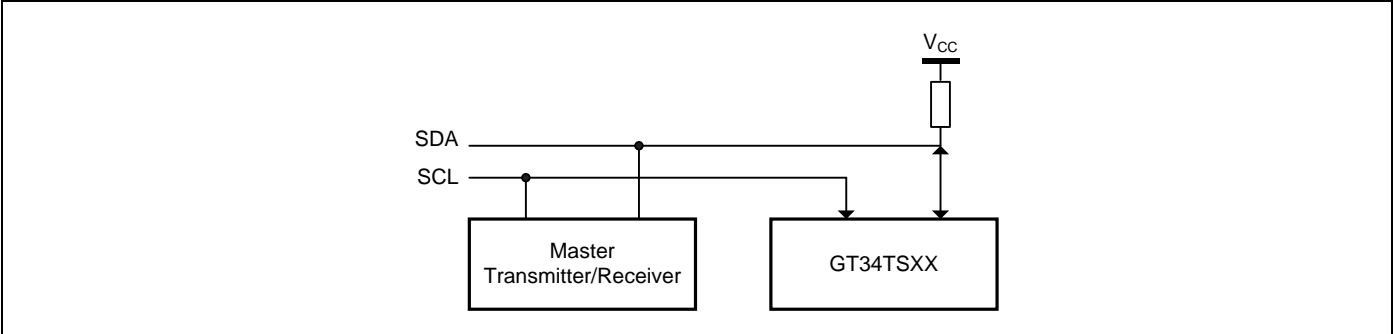

Figure 5-3. Start and Stop Conditions

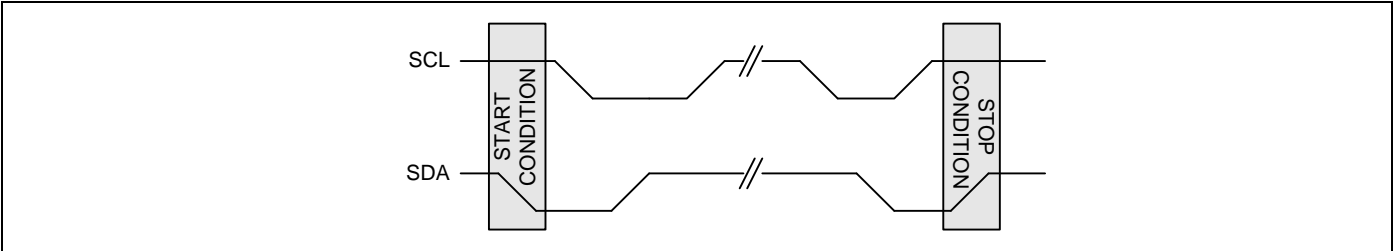

Figure 5-4. Data Validity Protocol

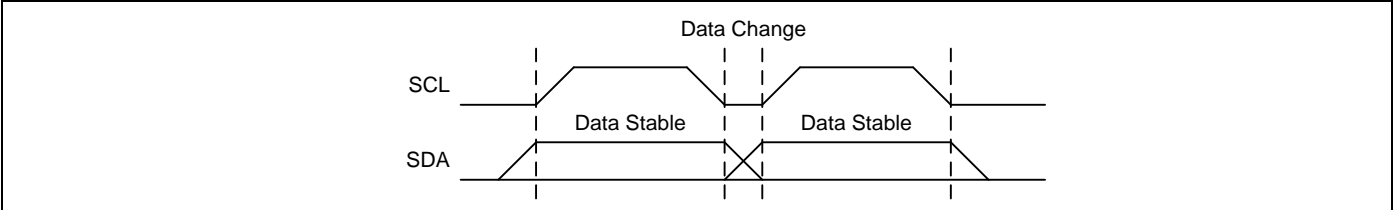

Figure 5-5. Output Acknowledge

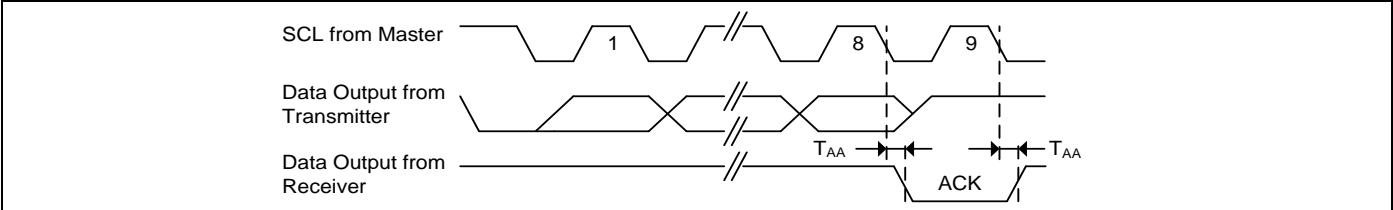



Figure 5-6. Bus Timing

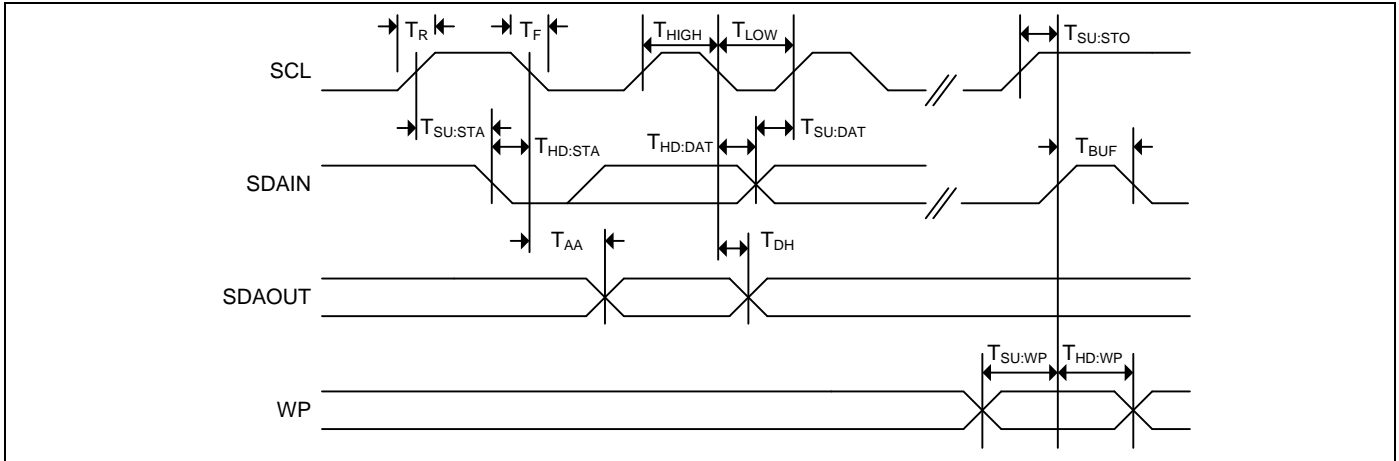
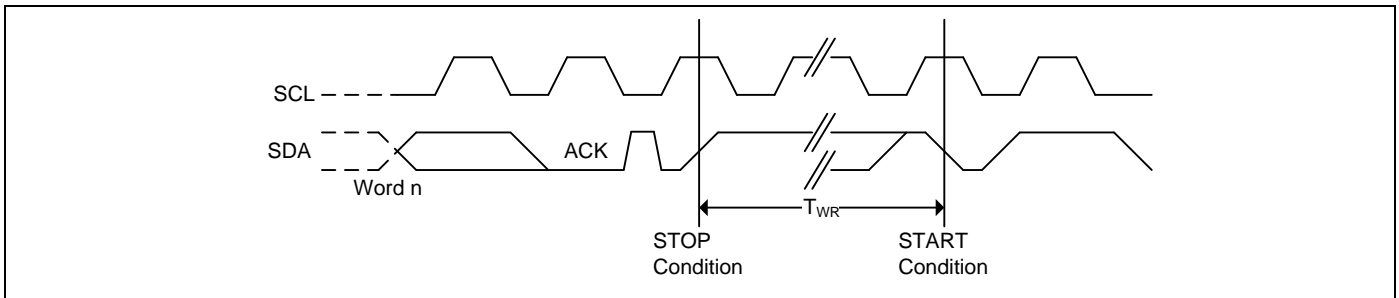

Figure 5-7. Write Cycle Timing





GT34TS02B

6. Temperature Sensor

6.1 TS Register Overview

The TS component in GT34TS02B includes various types of user-programmable registers. Their definitions and functions are described in the following sections.

The major registers are:

- Pointer register
- Capability register
- Configuration register
- Upper Alarm Window register
- Lower Alarm Window register
- Critical Limit register
- Temperature register
- Manufacturer ID register
- Device ID/Revision register

Table 6.1 TS Register Summary

Register Address	R/ \bar{W}	Default state	TS Register
N/A	W	N/A	Pointer register
00h	R	000Fh	Capability register (B-grade)
01h	R/ \bar{W}	0000h	Configuration register
02h	R/ \bar{W}	0000h	Upper Alarm Window register
03h	R/ \bar{W}	0000h	Lower Alarm Window register
04h	R/ \bar{W}	0000h	Critical Limit register
05h	R	N/A	Temperature register
06h	R	1C68h	Manufacturer ID register
07h	R	3301h	Device ID/Revision register
08h	R/ \bar{W}	0000h	SMBus Timeout status
09h	R/ \bar{W}	0001h	Selected Temperature Resolution

Note: Any illegal operations or write to invalid/reserved registers is prohibited.

6.2 Pointer Register

This register is an 8-bit register, which contains 3 selected bits: P0, P1 and P2.

Table 6.2 Pointer Register Format

MSB	Pointer register						LSB
Bit 7	Bit 6	Bit 5	Bit 4	Bit 3	Bit 2	Bit 1	Bit 0
0	0	0	0	0	P2	P1	P0

Note: P2, P1 and P0 are selected bits of pointer register.

Table 6.3 Pointer Register Description

P2	P1	P0	Name	Description	R/ \bar{W}	Default
0	0	0	TSCap	TS capability	R	000F
0	0	1	Conf	Configuration	R/ \bar{W}	0000
0	1	0	Upper	Upper Alarm Window	R/ \bar{W}	0000
0	1	1	Lower	Lower Alarm Window	R/ \bar{W}	0000
1	0	0	Critical	Critical Limit	R/ \bar{W}	0000
1	0	1	Temp	Temperature	R	0000



GT34TS02B

1	1	0	MID	Manufacturer ID	R	1C68h
1	1	1	DID	Device ID / Revision	R	3301h

6.3 Capability Register

This register is a 16-bit register with default value 000Fh

Table 6.4 Capability Register Format

MSB		Capability register (00h)						LSB	
Bit15	Bit14	Bit13	Bit12	Bit11	Bit10	Bit9	Bit8		
RFU	RFU	RFU	RFU	RFU	RFU	RFU	RFU		
0	0	0	0	0	0	0	0		
Bit7		Bit6	Bit5	Bit4	Bit3	Bit2	Bit1	Bit0	
EVSD		TMOU	X	Temperature resolution		Range	Accuracy	Alarm & Critical Trips	
0		0	0	0	1	1	1	1	

Table 6.5 Capability Register Description

Bit	Symbol	R/ \bar{W}	Description
0	Alarm & Critical Trips	R	Basic capability. 0: The device does not support interrupt capabilities. 1 (Default): Has Alarm and Critical Trips capability
1	Accuracy	R	Higher accuracy bit set during manufacture. 0: Accuracy $\pm 2^{\circ}\text{C}$ over the active range and $\pm 3^{\circ}\text{C}$ over the monitor range (C-grade) 1 (Default): Accuracy $\pm 1^{\circ}\text{C}$ over the active range and $\pm 2^{\circ}\text{C}$ over the monitor range (B-grade)
2	Range	R	0: The temperature monitor clamps values lower than 0°C . 1 (Default): can be read temperatures below 0°C and set sign bit accordingly
4:3	Temperature resolution	R	Temperature resolution 01 (Default): This 10-bit setting provides temperature at 0.25°C resolution (LSB) Others refer table 6.6
5	X	R	0: Not used. Default as 0.
6	TMOU	R	Bus timeout period for thermal sensor access during normal operation. 0(default): Parameter T_{TIMEOUT} is supported within the range of 10 to 60 ms. 1: Parameter T_{TIMEOUT} is supported within the range of 25 to 35 ms.
7	EVSD	R	$\overline{\text{EVENT}}$ with Shutdown action. ‘0’ (default) - The EVENT# output freezes in its current state when entering shutdown. Upon exiting shutdown, the EVENT# output remains in the previous state until the next thermal sample is taken, or possibly sooner if EVENT# is programmed for comparator mode. ‘1’ - The EVENT# output is deasserted (not driven) when entering shutdown, and remains deasserted upon exit from shutdown until the next thermal sample is taken,



GT34TS02B

			or possibly sooner if EVENT# is programmed for comparator mode.
15:8	RFU	R	Reserved for future use. Must be Zero.

Table 6.6 TRES Bit Decode

TRES[1:0]		TEMPERATURE RESOLUTION
1	0	0.5 °C (9-bit)
0	0	0.25 °C (10-bit) (default)
0	1	0.125 °C (11-bit)
1	0	0.0625 °C (12-bit)
1	1	

6.4 Configuration Register

This register is a 16-bit register with default value 0000h

Table 6.7 Configuration Register Format

MSB	Configuration register (01h)						LSB
Bit15	Bit14	Bit13	Bit12	Bit11	Bit10	Bit9	Bit8
RFU	RFU	RFU	RFU	RFU	Hysteresis		Shutdown TS
0	0	0	0	0	0	0	0
Bit7	Bit6	Bit5	Bit4	Bit3	Bit2	Bit1	Bit0
Critical Lock	$\overline{\text{EVENT}}$ Lock	Clear	$\overline{\text{EVENT}}$ Status	$\overline{\text{EVENT}}$ Control	Critical Event	$\overline{\text{EVENT}}$ Polarity	$\overline{\text{EVENT}}$ Mode
0	0	0	0	0	0	0	0

Table 6.8 Configuration Register Description

Bit	Parameter	R/ $\overline{\text{W}}$	Description
0	$\overline{\text{EVENT}}$ Mode	R/ $\overline{\text{W}}$	0: Comparator output mode (Default) 1: Interrupt mode • When either of the Alarm (6) or Critical (7) lock bit is set, this bit cannot be altered until unlocked
1	$\overline{\text{EVENT}}$ Polarity	R/ $\overline{\text{W}}$	0: Low (Default) 1: HIGH. • When either of the Alarm (6) or Critical (7) lock bit is set, this bit cannot be altered until unlocked.
2	Critical $\overline{\text{EVENT}}$	R/ $\overline{\text{W}}$	0: $\overline{\text{EVENT}}$ output on Alarm or Critical temperature event (Default) 1: $\overline{\text{EVENT}}$ only if temperature is above the value in the critical temperature register • When the alarm window lock bit (6) is set, this bit cannot be altered until unlocked.
3	$\overline{\text{EVENT}}$ Control	R/ $\overline{\text{W}}$	0: $\overline{\text{EVENT}}$ output disabled (Default) 1: $\overline{\text{EVENT}}$ output enabled



GT34TS02B

Bit	Parameter	R/ \bar{w}	Description
			<ul style="list-style-type: none"> When either of the lock bits (6 or 7) is set, this bit cannot be altered until unlocked.
4	$\overline{\text{EVENT}}$ Status	R	0: Not assert $\overline{\text{EVENT}}$ output condition (Default) 1: Assert $\overline{\text{EVENT}}$ output condition due to Alarm Window or Critical Trip condition. <ul style="list-style-type: none"> The actual event causing the event can be determined from the Read Temperature register. Interrupt $\overline{\text{EVENT}}$ can be cleared by writing to the 'clear $\overline{\text{EVENT}}$' bit. Writing to this bit will have no effect
5	Clear	W	Clear $\overline{\text{EVENT}}$ 0: No-effect (Default) 1: Clears active $\overline{\text{EVENT}}$ in Interrupt mode. <ul style="list-style-type: none"> When read, this register always returns zero. Writing to this register has no effect in Comparator mode.
6	$\overline{\text{EVENT}}$ Lock	R/ \bar{w}	Alarm Window Lock bit 0: Upper and Lower Alarm Window registers are unlocked and can be altered (Default). 1: Upper and Lower Alarm Window registers are locked and setting cannot be altered. <ul style="list-style-type: none"> Once power-up, this bit is initially cleared. When set, this bit will return a 1 and remains locked until cleared by internal power-on reset This bit can be written with a single write and does not require double writes
7	Critical Lock	R/ \bar{w}	Critical Lock bit 0: Critical Limit register is unlocked and can be altered (Default) 1: Critical Limit register settings is locked and cannot be changed. <ul style="list-style-type: none"> Once power-up, this bit is initially cleared. When set, this bit becomes a 1, and remains locked until cleared by internal Power-on reset This bit can be written with a single write and do not require double writes.
8 ^[1]	Shutdown TS	R/ \bar{w}	0: Enable TS (Default) 1: Disable TS <ul style="list-style-type: none"> When disabled, entire TS component is shut down and enter into standby mode to save power, no events will be generated. However, all registers may be read or written to. When either of the lock bits (6 or 7) is set, this bit cannot be set to 1 until they are unlocked. However, this bit can be cleared to 0 at any time. Also, power cycling will clear this bit and enable the TS to active mode.
10:9	Hysteresis	R/ \bar{w}	00: Disable hysteresis (Default) 01: Enable hysteresis at 1.5°C 10: Enable hysteresis at 3°C 11: Enable hysteresis at 6°C <ul style="list-style-type: none"> When enabled, hysteresis is applied to temperature movement around trigger points. Refer to Hysteresis section below for details.
15:11	RFU	R	Reserved for future use. Must be Zero

Note: ^[1] If either Bit 6 or Bit 7 is set, then this bit can't be set until they are unlocked.



GT34TS02B

6.4.1 Hysteresis

Hysteresis is applied in the following conditions like the Table 6.8, Table 6.9 and Figure 6-1.

- For example, consider the behavior of the 'Above Alarm Window' bit (Bit14) of the Temperature register with the hysteresis being set to 3 °C setting. As the ambient temperature rises and exceeds the alarm window, (i.e., when the Temperature register contains a value that is greater than the value of the Upper Alarm Window register), then Bit14 will be set to 1. If the ambient temperature decreases, Bit14 will remain set unless the measured temperature is less than or equal to 3°C below the value in the Upper Alarm Window register

- Similarly, the 'Below Alarm Window' bit (Bit13) of the Temperature register will be set to 0 when the value in the Temperature register is equal to or greater than the value in the Lower Alarm Window register. However, once the temperature decreases to less than the value in the Lower Alarm Window register minus 3°C, Bit13 will be set to 1.
- Note that hysteresis is also applied to $\overline{\text{EVENT}}$ pin functionality. When either of the lock bits (6 & 7) is set, these bits cannot be altered.

Table 6.9 Hysteresis Applied Condition

	Below Alarm window bit		Above Alarm window bit	
	Temperature slope	Threshold temperature	Temperature slope	Threshold temperature
Sets	Falling	$T_{LAW} - H_{YST}$	Rising	T_{UAW}
Clears	Rising	T_{LAW}	Falling	$T_{UAW} - H_{YST}$

Note: T_{UAW} = Upper Alarm Window value; T_{LAW} = Lower Alarm Window value; H_{YST} = Absolute value of selected hysteresis; T_{CA} = Critical Alarm value

Figure 6.1 Hysteresis Applied Condition

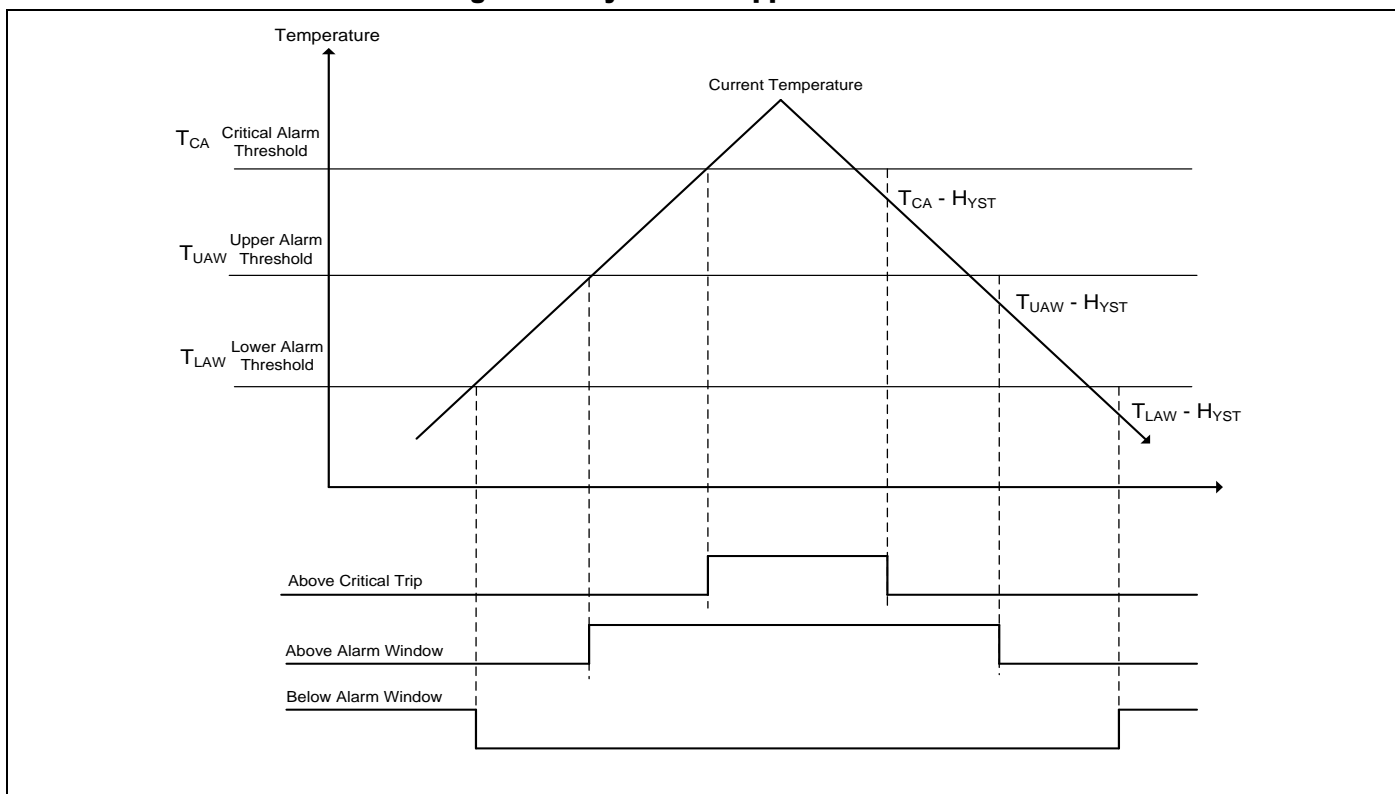



GT34TS02B

6.5 Upper Alarm Window Register

This register is a 16-bit register holding the Upper Alarm Window temperature value

- LSB equals to 0.25°C

Table 6.10 Upper Alarm Window Register Format

			MSB											LSB		
Bit15	Bit14	Bit13	Bit12	Bit11	Bit10	Bit9	Bit8	Bit7	Bit6	Bit5	Bit4	Bit3	Bit2	Bit1	Bit0	
0	0	0	Sign	Upper Alarm Window Temperature value										0	0	

6.6 Lower Alarm Window Register

This register is a 16-bit register holding the Lower Alarm Window temperature value

- LSB equals to 0.25°C

Table 6.11 Lower Alarm Window Register Format

			MSB											LSB		
Bit15	Bit14	Bit13	Bit12	Bit11	Bit10	Bit9	Bit8	Bit7	Bit6	Bit5	Bit4	Bit3	Bit2	Bit1	Bit0	
0	0	0	Sign	Lower Alarm Window Temperature value										0	0	

6.7 Critical Alarm Register

This register is a 16-bit register holding the Critical Alarm temperature value

- LSB equals to 0.25°C

Table 6.12 Critical Alarm Register Format

			MSB											LSB		
Bit15	Bit14	Bit13	Bit12	Bit11	Bit10	Bit9	Bit8	Bit7	Bit6	Bit5	Bit4	Bit3	Bit2	Bit1	Bit0	
0	0	0	Sign	Critical Alarm Temperature value										0	0	

6.8 Temperature Register

This register is a 16-bit register holding the temperature value

- The data of this register can be read at any time without interrupting the temperature conversion
- The LSB (0) equals to 0.0625°C
- Bits 13 to 15 are limit setting bits

Table 6.13 Temperature Register Description

Bit	Symbol	Access	Description
12:0	TEMP	R	Temperature Value (2's complement). (LSB = 0.0625°C)



GT34TS02B

Table 6.14 Temperature Register Format

			MSB	Temperature value											LSB
Bit15[*]	Bit14[*]	Bit13[*]	Bit12	Bit11	Bit10	Bit9	Bit8	Bit7	Bit6	Bit5	Bit4	Bit3	Bit2	Bit1	Bit0
Above Critical Alarm	Above Alarm Window	Below Alarm Window	Sign	128	64	32	16	8	4	2	1	0.5	0.25*	0.125*	0.0625*

Note: * Resolution defined based on value of TRES field of the Capabilities Register. Unused/unsupported bits will read as 0.

Table 6.15 Temperature Register Coding Examples

B15-B0 (Binary)	Value	Units
XXX0 0000 0010 11xx	+2.75	°C
XXX0 0000 0001 00xx	+1.00	°C
XXX0 0000 0000 01xx	+0.25	°C
XXX0 0000 0000 00xx	0	°C
XXX1 1111 1111 11xx	-0.25	°C
XXX1 1111 1111 00xx	-1.00	°C
XXX1 1111 1101 01xx	-2.75	°C

Table 6.16 Bit[15], Bit[14], Bit[13] Description

Bit #	Definition with Hysteresis = 0
13	<p>Below Alarm Window</p> <ul style="list-style-type: none"> 0 : temperature is equal to or above the Lower Alarm Window register 1 : temperature is below the Lower Alarm Window register <p>When the temperature is below the Lower Alarm Window value, this bit is set and will remain set as long as the temperature is below the Lower Limit minus the hysteresis. When the temperature meets or exceeds the Lower Limit, it will only be cleared.</p>
14	<p>Above Alarm Window</p> <ul style="list-style-type: none"> 0 : temperature is equal to or below the Upper Alarm Window register 1 : temperature is above Upper Alarm Window register <p>When the temperature is above the Upper Alarm Window value, this bit is set and will remain set as long as the temperature is above the Upper value. Once when the temperature drops below or equal to the Upper value minus the hysteresis, it will be cleared.</p>
15	<p>Above Critical Alarm</p> <ul style="list-style-type: none"> 0 : temperature is below the Critical Alarm register setting 1 : temperature is equal to or above the Critical Alarm register setting <p>When the temperature is above the Critical Alarm, this bit is set and will remain set as long as the temperature is above Critical Alarm. Once the temperature has dropped below the limit minus the hysteresis, it will automatically be cleared.</p>



GT34TS02B

6.9 Manufacturer's ID Register

This register is a 16-bit register for Manufacturer ID (1C68h).

6.10 Device ID Register

This register is a 16-bit register for Device ID (3301h)

- The upper byte stores a unique number Device ID
- The lower byte holds the revision value

6.11 SMBus Timeout Register

The SMBus Register allows the user to enable or disable the SMBus time out feature

Bits15 - 8 -- RFU - Reserved for future use. These bits will always read '0' and writing to them will have no effect.

Bit7 - SMBOUT -- When the SMBOUT is set to '0', the SMBus Timeout function is supported within the range of 10 to 60 ms. If the SMBOUT is set to '1', the SMBus Timeout function is supported within the range of 25 to 35 ms.

This bit decides the value of parameter $T_{TIMEOUT}$ of the Capability Register.

Bits6 - 0 -- RFU - Reserved for future use. These bits will always read '0' and writing to them will have no effect.

This bit can be set when Temperature Sensor enter shutdown mode.

When either of the Crit_Alarm Trip or Alarm Window lock bits is set, this bit cannot be altered until unlocked.

Table 6.17 Temperature Resolution Register

ADDR	R/ \bar{W}	B15/B7	B14/B6	B13/B5	B12/B4	B11/B3	B10/B2	B9/B1	B8/B0	Default
08	R/ \bar{W}	0	0	0	0	0	0	0	0	0000
		SMBOUT	0	0	0	0	0	0	0	

6.12 Temperature Resolution Register

With this register a user can program the temperature sensor resolution from 9-12 bits as shown below. The power-on default is always 10 bit (0.25 °C/LSB). The selected resolution RES[1:0] is also reflected in bits (4:3) (TRES1:TRES0) of the capability register.

Table 6.18 Temperature Resolution Register

ADDR	R/ \bar{W}	B15/B7	B14/B6	B13/B5	B12/B4	B11/B3	B10/B2	B9/B1	B8/B0	Default
09	R/ \bar{W}	0	0	0	0	0	0	0	0	0001
		0	0	0	0	0	0	0	RES[1:0]	

Note: In order to prevent accidentally writing the resolution register to higher resolution and exceeding the maximum temperature conversion time of $t_{CONV} = 125$ ms, a Shutdown Command (using the CONFIG register) is required to change the resolution register. The device must be in shutdown mode to change the resolution.

Table 6.19 Resolution Bit Decode

RES[1:0]		Temperature Resolution
0	0	0.5°C (9-bit)
0	1	0.25°C (10-bit)
1	0	0.125°C (11-bit)
1	1	0.0625°C (12-bit)



GT34TS02B

6.13 $\overline{\text{EVENT}}$ output

The $\overline{\text{EVENT}}$ pin is an open-drain output whose function can be programmed as an interrupt, comparator, or critical alarm mode.

6.13.1 Interrupt Mode

When the temperature exceeds the value in either the Upper or Lower Alarm Window register, the device will trigger the $\overline{\text{EVENT}}$ interrupt. By writing a "1" to the Clear $\overline{\text{EVENT}}$ Bit[5] of Configuration Register will clear the status.

6.13.2 Comparator Mode

The $\overline{\text{EVENT}}$ pin remains asserted until the temperature falls below the value programmed in the Upper Alarm Window register or rises above the value programmed in the Lower Alarm Window register, or until the range of these alarm registers are reprogrammed and the temperature falls inside the Alarm limits.

6.13.3 Critical Mode

When the temperature reaches beyond a critical temperature, the device switches to the comparator mode automatically and triggers the $\overline{\text{EVENT}}$ interrupt. Such state will remain as long as the temperature stays above the critical setting. Under such condition, the $\overline{\text{EVENT}}$ Status cannot be cleared through the clear $\overline{\text{EVENT}}$ bit or SMBus Alert.

When the temperature drops below critical temperature, the $\overline{\text{EVENT}}$ output can be only cleared and the device reverts back to either interrupt or comparator mode, pending upon the programmed status of Bit 0 ($\overline{\text{EVENT}}$ mode) in the Configuration register. Or performing the SMBus Alert Response address (ARA), if SMBus is utilized.

All event thresholds use hysteresis as programmed in the Configuration register.

Figure 6.2 Hysteresis Applied Condition

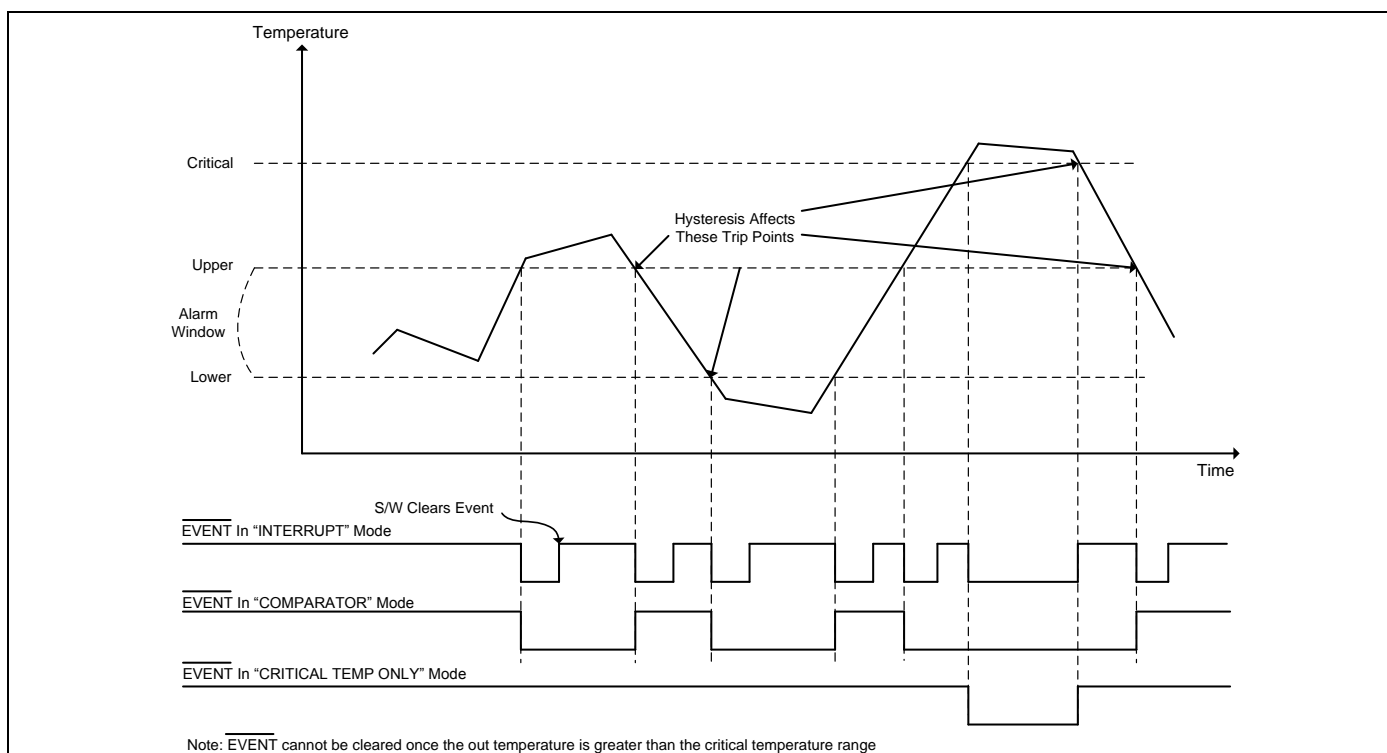

6.14 Alarm window

The alarm window consists of two registers: an Upper Alarm Window register (02h) and a Lower Alarm Window register (03h). The Upper Alarm Window register holds the upper

temperature point, while the Lower Alarm Window register holds the lower temperature point. When the $\overline{\text{EVENT}}$ control is enabling, the $\overline{\text{EVENT}}$ output will be triggered whenever entering or exiting the alarm window.



GT34TS02B

7. EEPROM Functional Description

7.1 Read and Write Operation

For EE, all functions on Read, Write, software protections and others are the same as GT34C02, which includes byte

write, page write, random access read, current address read, sequential read, SWP, CWP and PSWP.

Figure 7.1 Command Configuration

Pin Connection ^[1]			Slave Device Address									
A2	A1	A0	Bit	7	6	5	4	3	2	1	0	
A2	A1	A0		1	0	1	0	A2	A1	A0	R/W	Normal Instruction ^[2]
A2	A1	A0		0	1	1	0	A2	A1	A0	R/W	Permanent Write Protection Instruction ^[2]
GND	GND	V _{HV}		0	1	1	0	0	0	1	0	Set Write Protection (SWP)
GND	V _{CC}	V _{HV}		0	1	1	0	0	1	1	0	Clear Write Protection (CWP)
GND	GND	V _{HV}		0	1	1	0	0	0	1	1	Read SWP
GND	V _{CC}	V _{HV}		0	1	1	0	0	1	1	1	Read CWP

Notes:

^[1] A2-A0 input pin connections must be GND (or floating), V_{CC} or V_{HV}

^[2] Bits 1, 2 and 3 of the device address will be compared with the values on the external pins

Figure 7.2 Byte Write

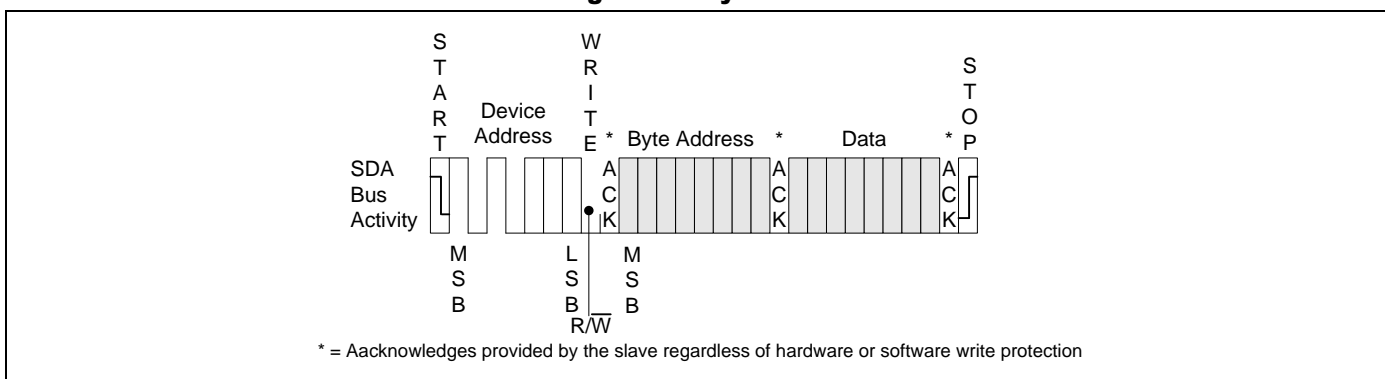



GT34TS02B

Figure 7.3 Page Write

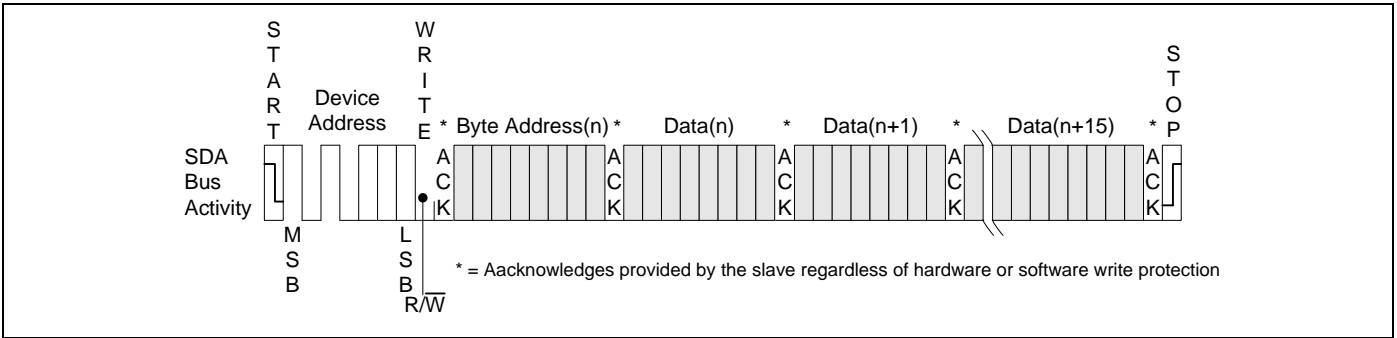

Figure 7.4 Current Address Read

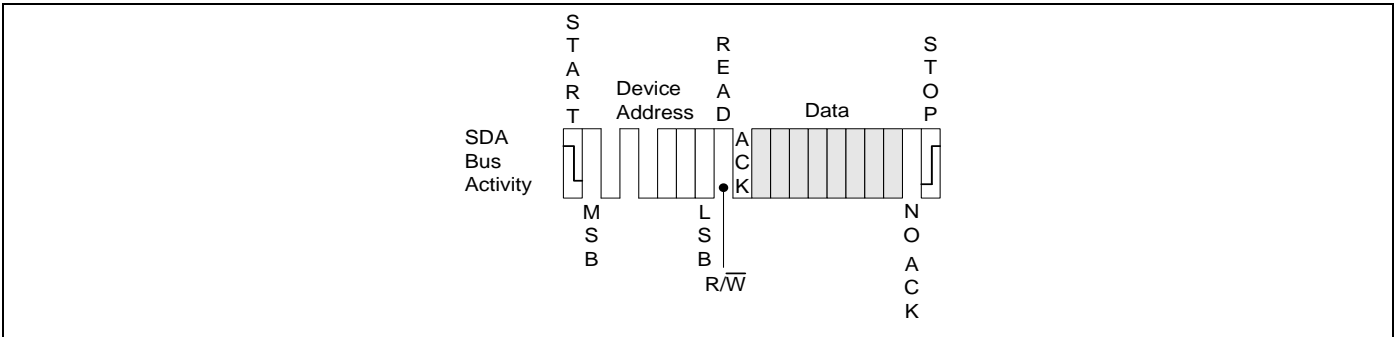

Figure 7.5 Random Address Read

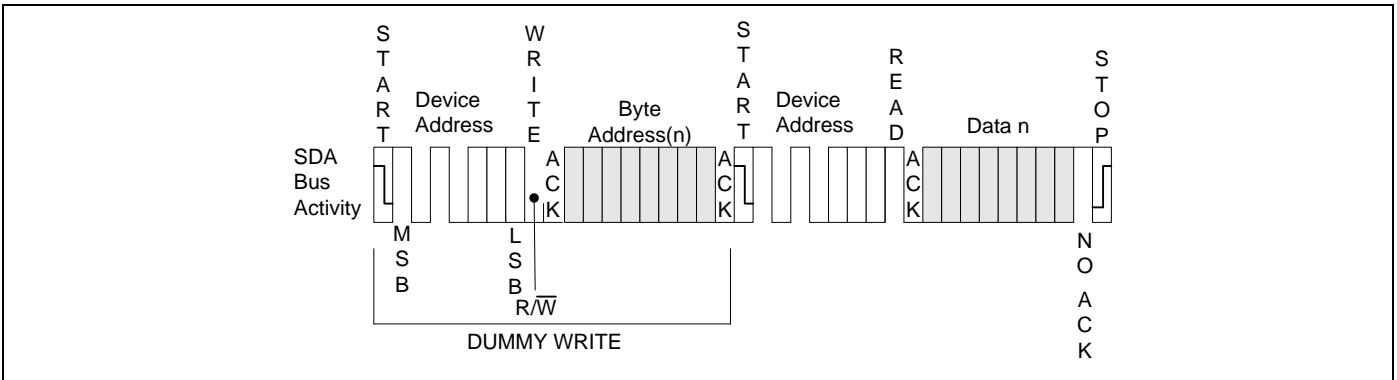
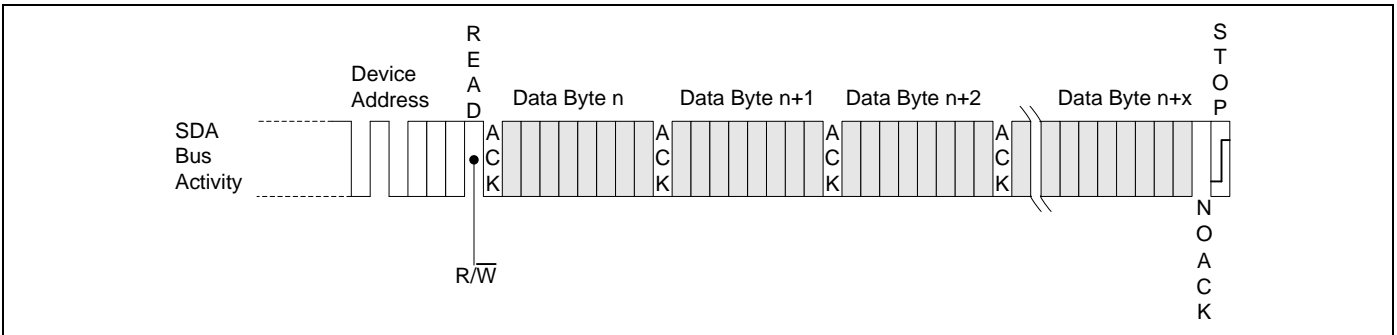

Figure 7.6 Sequential Read





GT34TS02B

7.2 Write Protection

7.2.1 Software Write Protection

The EEPROM has two software write-protection features, allowing the lower half of the memory area (addresses 0x00 to 0x7F) to be temporarily or permanently write protected. Software write-protection is handled by three instructions:

- SWP: Set Write Protection
- CWP: Clear Write Protection
- PSWP: Permanently Set Write Protection

The level of write-protection (set or cleared) that has been defined using these instructions, remains defined even after a power cycle.

7.2.2 SWP and CWP

If the software write-protection has been set with the SWP instruction, it can be cleared again with a CWP instruction. The two instructions (SWP and CWP) have the same format as a Byte Write instruction, but with a different Device Type Identifier. Like the Byte Write instruction, it is followed by an address byte and a data byte, but in this case the contents are all “Don't Care”. Another difference is that the voltage, V_{HV} must be applied on the A0 pin, and specific logical levels must be applied on the other two A1 pin and A2 pin.

7.2.3 PSWP

If the software write-protection has been set with the PSWP instruction, the first 128 bytes of the memory are permanently write-protected. This write-protection cannot be cleared by any instruction, or by power-cycling the

device. Also, once the PSWP instruction has been successfully executed, the SPD EE no longer acknowledges any instruction (with a Device Type Identifier of 0110) to access the write-protection settings. The slave respond with ACK or No ACK depends on the flag status (See Table 7.1)

7.3 Reading Write Protection Status

The status of software write protection can be determined using these instructions:

- Read SWP: Read Write Protection Status
- Read PSWP: Read Permanently Set Write Protection Status

7.3.1 Read SWP

The host issues a Read SWP command. If Software Write Protection has not been set, the device replies to the data byte with an Ack. If Software Write Protection has been set, the device replies to the data byte with a NoAck (See Table 7.1).

7.3.2 Read PSWP

The host issues a Read PSWP command. If Permanent Software Write Protection has not been set, the device replies to the data byte with an Ack. If Permanent Software Write Protection has been set, the device replies to the data byte with a NoAck (See Table 7.1).



GT34TS02B

Figure 7.7 Set PSWP

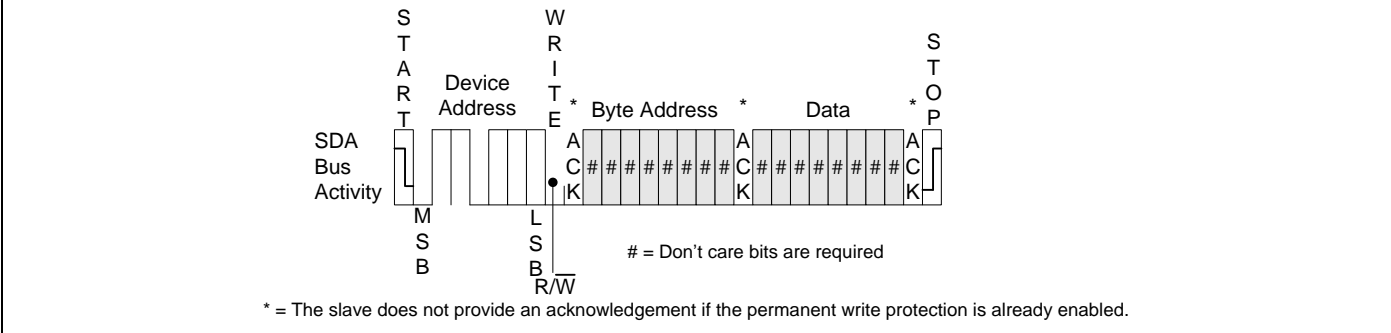
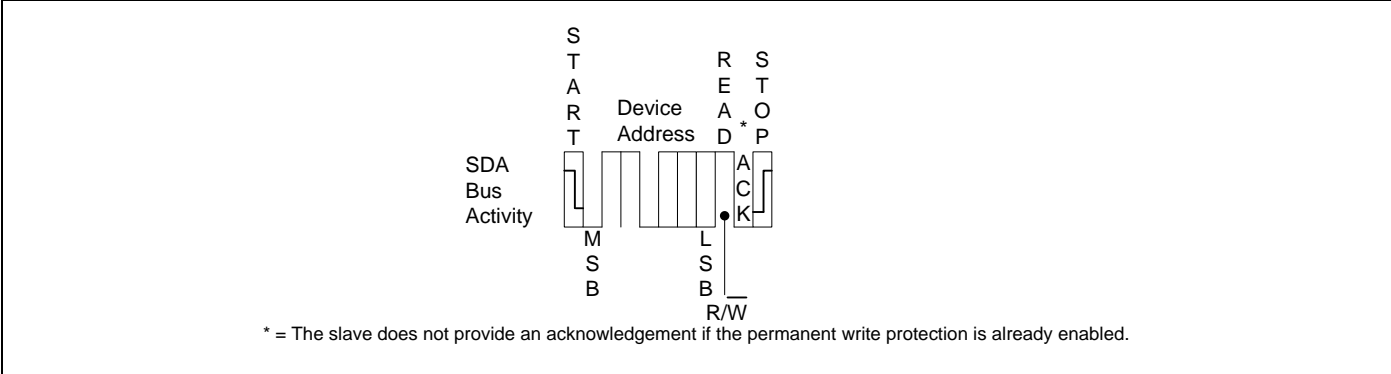

Figure 7.8 Read PSWP





GT34TS02B

Table 7.1 ACK Status

Normal Instructions								
Command	PSWP (Permanent)	RSWP (Reversible)	ACK command	Address	ACK Address	Data Byte	Data Byte ACK	Write Cycle
Read	X	X	ACK	00h-FFh	ACK	Data Byte	ACK	No
Write	0	0	ACK	00h-FFh	ACK	Data Byte	ACK	Yes
Write	1	X	ACK	00h-7Fh	ACK	Data Byte	NoACK	No
Write	X	1	ACK	00h-7Fh	ACK	Data Byte	NoACK	No
Write	X	X	ACK	80h-FFh	ACK	Data Byte	ACK	Yes
Permanent Instructions								
Command	PSWP (Permanent)	RSWP (Reversible)	ACK command	Address	ACK Address	Data Byte	Data Byte ACK	Write Cycle
Read PSWP Status ^[3]	0	X	ACK	Dummy Address	NoACK	Dummy Byte	NoACK	No
Read PSWP Status	1	X	NoACK	-	-	-	-	No
Set PSWP	0	X	ACK	Dummy Address	ACK	Dummy Byte	ACK	Yes
Set PSWP	1	X	NoACK	-	-	-	-	No
Reversible Instructions								
Command	PSWP (Permanent)	RSWP (Reversible)	ACK command	Address	ACK Address	Data Byte	Data Byte ACK	Write Cycle
Read SWP Status ^[3]	0	0	ACK	-	-	-	-	No
Read SWP Status	0	1	NoACK	-	-	-	-	No
Read SWP Status ^[3]	1	0	NoACK	-	-	-	-	No
Read SWP Status	1	1	NoACK	-	-	-	-	No
Read CWP status ^[2,3]	0	X	ACK	-	-	-	-	No
Read CWP status ^[2]	1	X	NoACK	-	-	-	-	No
Set RSWP	0	0	ACK	Dummy Address	ACK	Dummy Byte	ACK	Yes
Set RSWP	0	1	NoACK	-	-	-	-	No
Set RSWP	1	0	NoACK	-	-	-	-	No
Set RSWP	1	1	NoACK	-	-	-	-	No
Clear RSWP	0	0	ACK	Dummy Address	ACK	Dummy Byte	ACK	Yes
Clear RSWP	1	0	NoACK	-	-	-	-	No
Clear RSWP	0	1	ACK	Dummy Address	ACK	Dummy Byte	ACK	Yes
Clear RSWP	1	1	NoACK	-	-	-	-	No

Note:^[1] X = Don't care

^[2] Read CWP status yields the same result as Read PSWP Status

^[3] Read out Don't Care Dummy Address and Dummy Data is optional



GT34TS02B

8. Electrical Characteristics

8.1 Absolute Maximum Ratings

Symbol	Parameter	Value	Unit
V_{CC}	Supply Voltage	-0.3 to + 4.2	V
V_N	Voltage on SDA, SCL, A1, A2 and $\overline{\text{EVENT}}$ Pins	-0.3 to + 4.2	V
V_{A0}	Voltage on pin A0	-0.3 to +10	V
I_{sink}	Sink Current on SDA, SCL and $\overline{\text{EVENT}}$ Pins	-1 to +12.0	mA
$T_{J(\text{max})}$	Maximum Junction Temperature	150	°C
T_{stg}	Storage Temperature	-65 to +150	°C

Note: Stress greater than those listed under Absolute Maximum Ratings may cause permanent damage to the device. This is a stress rating only and functional operation of the device at these or any other condition outside those indicated in the operational sections of this specification is not implied. Exposure to absolute maximum rating conditions for extended periods may affect reliability.

8.2 Operating Range

Ambient Temperature (T_A)	V_{CC}
-40°C to +125°C	1.7V to 3.6V

8.3 Capacitance

Symbol	Parameter ^[1, 2]	Conditions	Max.	Unit
C_{IN}	Input Capacitance	$V_{IN} = 0V$	6	pF
$C_{I/O}$	Input / Output Capacitance	$V_{I/O} = 0V$	8	pF

Notes: ^[1] Tested initially and after any design or process changes that may affect these parameters and not 100% tested.

^[2] Test conditions: $T_A = 25^\circ\text{C}$, $f = 1\text{ MHz}$, $V_{CC} = 1.7\text{V to }3.6\text{V}$, unless otherwise specified.



GT34TS02B

8.4 DC Electrical Characteristic

$V_{CC} = 1.7V$ to $3.6V$, $T_{amb} = -40\text{ }^{\circ}C$ to $+125\text{ }^{\circ}C$, unless otherwise specified

Symbol	Parameter ^[1]	Conditions	Min.	Typ.	Max.	Unit
V_{CC}	Supply voltage		1.7	3.3	3.6	V
$I_{LIH}, I_{LIL}, I_{LOH}, I_{LOL}$	Input/Output Leakage current	$V_{PIN}=V_{CC}$ or GND			± 4	μA
I_{SB1}	Standby supply current	TS shutdown , EE standby			5	μA
I_{SB2}	Shut down current	TS active, EE standby			500	μA
I_{CC}	Supply current	TS shutdown and EE active			2	mA
V_{IH}	Input High Voltage	SCL, SDA	$0.7 * V_{CC}$		$V_{CC}+0.5$	V
V_{IL}	Input Low Voltage	SCL, SDA	-0.5		$0.3 * V_{CC}$	V
V_{HV}	A0 High Voltage	$V_{HV} - V_{CC} \geq 4.8V$	7		10	V
V_{OL}	Output Low Voltage	$I_{OL}=2.1mA, 1.7V \leq V_{CC} \leq 3.6V$			0.4	V
		$I_{OL}=0.7mA, V_{CC}=1.7V$			0.2	
I_{OL_EVENT}	Output Low Sink Current on \overline{EVENT}	$V_{OL}=0.4V$	1			mA
I_{OL_SDA}	Output Low Sink Current on SDA	$V_{OL}=0.6V$	6			mA
TS_{Acc}	Temperature sensor (TS) accuracy (B-grade)	$T_{amb} = 70\text{ }^{\circ}C$ to $95\text{ }^{\circ}C$			± 1.0	$^{\circ}C$
		$T_{amb} = 40\text{ }^{\circ}C$ to $125\text{ }^{\circ}C$			± 2.0	$^{\circ}C$
		$T_{amb} = -40\text{ }^{\circ}C$ to $125\text{ }^{\circ}C$			± 3.0	$^{\circ}C$
TS_{Res}	TS Resolution	12-bit ADC			0.0625	$^{\circ}C/LSB$
R_{ADC}	ADC Resolution				12	Bits
TS_{Conv}	Conversion Rate				125	ms

Notes: ^[1] Not all parameters are 100% tested.

This specification only indicates how often temperature information is updated to the Temperature Register.

Accuracy (express in $^{\circ}C$) = difference between the output temperature and the measured temperature



GT34TS02B

8.5 AC Electrical Characteristic

$V_{CC} = 1.7V$ to $3.6V$, $T_{amb} = -40\text{ }^{\circ}C$ to $+125\text{ }^{\circ}C$, unless otherwise specified

Symbol	Parameter [1]	Min.	Typ.	Max.	Unit
F_{SCL}	SCL clock frequency	10		400	kHz
T_{LOW}	Low period of SCL clock	1300			ns
T_{HIGH}	High period of SCL clock	600			ns
T_{BUF}	Bus free time between a Stop and a Start conditions	1300			ns
$T_{SU;STA}$	Start condition Setup time	600			ns
$T_{HD;STA}$	Start condition Hold time	600			ns
$T_{SU;STO}$	Stop condition Setup time	600			ns
$T_{SU;DAT}$	Data In Setup time	100			ns
$T_{HD;DAT}$ [2]	Data In Hold time	0			ns
T_{DH}	Data Out Hold Time	200		900	ns
T_{AA}	SCL Low to SDA Data Out	200		900	ns
T_{WR}	Write Cycle			5	ms
T_R	Rise time of SDA and SCL			300	ns
T_F	Fall time of SDA and SCL			300	ns
T	Noise Suppression time			100	ns
T_{PU} [3]	Power-up to temperature measurement	250			ms
$T_{time-out}$ [4]	Bus time-out (TS only)	20		50	ms

Notes: [1] Not all parameters are 100% tested.

[2] For the SMBus, 300 ns data in hold time, $T_{HD;DAT}$, is required.

[3] After V_{CC} reaches the nominal value, 250msec is required prior to a valid temperature measurement

[4] The SMBus has a time-out of up to 50 ms for TS.



GT34TS02B

9. Ordering Information

T_{amb} = -40 °C to +125 °C, Lead-free

Voltage Range	Part Number*	Package (8-pin)*
1.7V to 3.6V	GT34TS02B-2UDLI-TR	2 x 3 x 0.55 mm Ultra-thin DFN

*

1. Contact Giantec Sales Representatives for availability and other package information.
2. The listed part numbers are packed in tape and reel "-TR". UDFN is 5K per reel.
3. Refer to Giantec website for related declaration document on lead free, RoHS, halogen free or Green, whichever is applicable.
4. Giantec offers Industrial grade for Commercial applications (0°C to +70°C).



GT34TS02B

10. Top Markings

10.1 UDFN Package



GT: Giantec Logo
81B: GT34TS02B-2UDLI-TR
YWW: Date Code, Y=year, WW=week



GT34TS02B

11. Package Information

11.1 UDFN

8L 2x3mm UDFN Package Outline

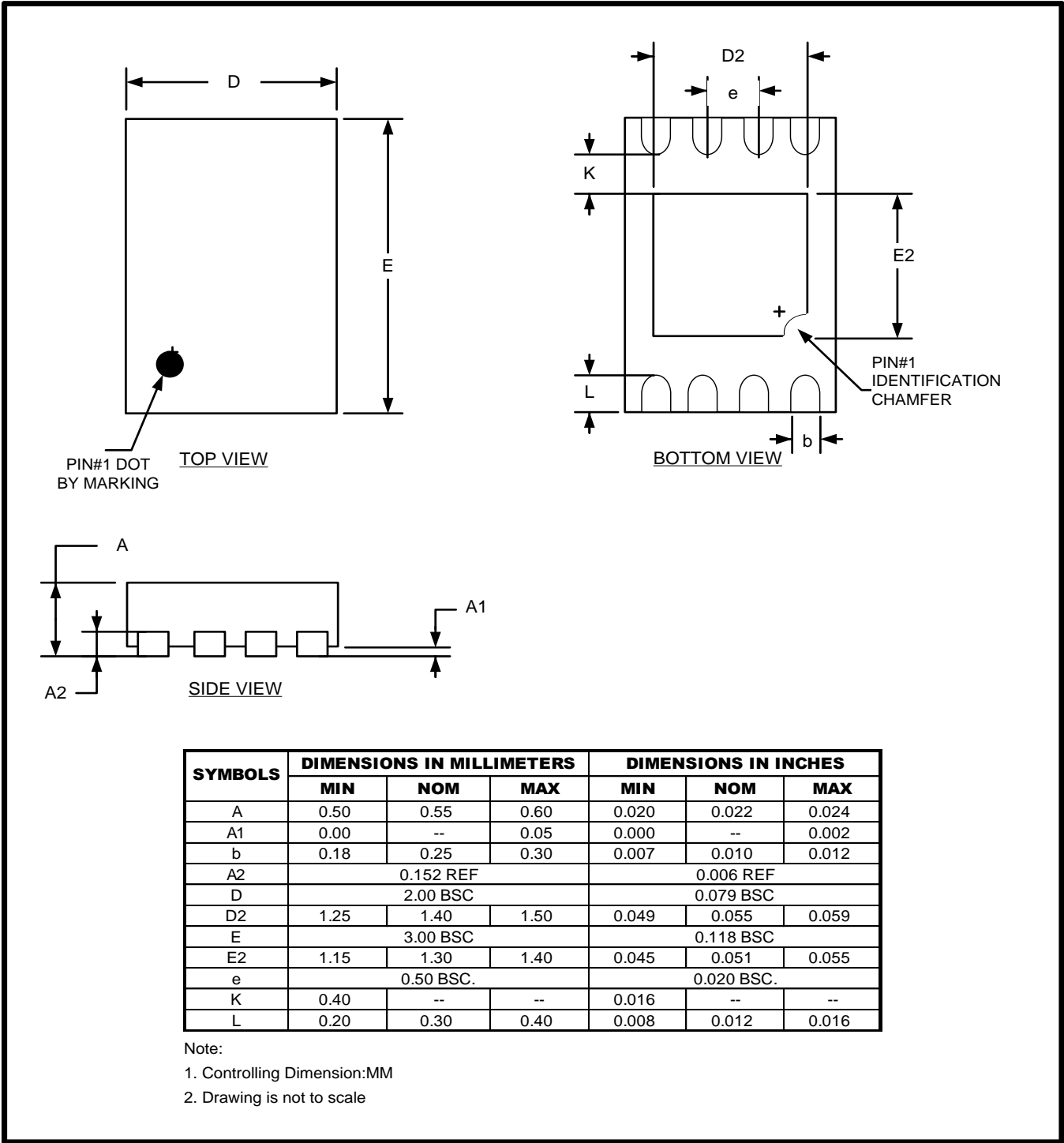



GT34TS02B

12. Revision History

Revision	Date	Descriptions
A0	Dec. 2013	Initial version
A1	Sep.2015	Function improved version
A2	Sep.2016	Temperature register coding example added
A3	Oct. 2016	Add SMBUS register and temperature resolution register