



FEATURES

- > Hermetically Sealed – Designed to meet: UL1604 for Class I & II, Div 2 and Class III for use in hazardous locations, IP67 for temporary water immersion for 30 min, SAE J1171 - external ignition protection, and ISO8846 for protection against ignition around flammable gasses.
- > Meets CE Conformance standards and is UL508 Certified.
- > High Efficiency Dual DC Coils – Very low 12, 24, or 48VDC continuous coil power with no EMI emissions or cross-talk on your system control power. Ideal for battery powered systems or where low power is needed. PWM coil options provide additional drive control flexibility.
- > Built-in coil suppression for all DC coils – Saves you engineering time and parts cost to add external coil suppression.
- > Stainless steel hardware and mounting inserts, for years of corrosion free service.
- > Not position sensitive – can be mounted in any position for ease of installation.

PRODUCT SPECIFICATIONS

Specifications	Units	Data
Contact Arrangement (main)	Form X	SPST-NO
Contact Arrangement (Auxiliary) 1/	Form A	SPST-NO
	Form C	SPST-NC
Mechanical Life	cycles	1,000,000
Contact Resistance		
Max @ rated carry current	mohms	.4
Typical @ rated carry current	mohms	.15 to .3
Operate time, 25°C		
Close (includes bounce) Max	ms	20
Close (includes bounce) Typical	ms	13
Bounce on close, Max	ms	7
Release time (includes arc time at max. break current)	ms	12
Insulation Resistance	Mohms	100 2/
Dielectric at sea level (leakage < 1mA)	VRMS	2,200
Shock, sawtooth 11msec, 1/2 sine 11msec	G's peak	25
Vibration, Sinusoidal (10-2000 Hz peak)	G's	25
Operating ambient Temp Range	°C	-55 to +85 3/
Storage ambient Temp Range	°C	-70 to +150
Weight, typical without nuts and washers	Kg (Lb)	0.38 (0.84)

POWER SWITCHING

DC POWER SWITCHING CYCLES

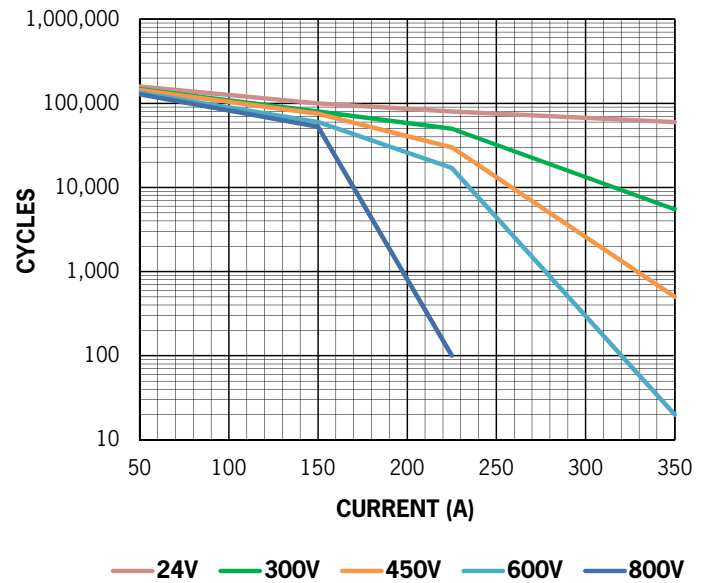

COIL RATINGS at 25°C

Coil P/N Designation	B 10/	C 10/	F 10/	M	N	P 4/	Q 4/
Coil Voltage, Nominal	12 VDC	24 VDC	48 VDC	12/24 VDC	48 VDC	12/24 VDC	48 VDC
Coil Type	Dual	Dual	Dual	PWM	PWM	Ext. PWM	Ext. PWM
Coil Voltage, Max 5/	16 VDC	32 VDC	64 VDC	36 VDC	95 VDC	36 VDC	95 VDC
Pick-Up Voltage, Max 6/ 8/ 9/	8 VDC	16 VDC	40 VDC	8.5 VDC	32 VDC		
Drop-Out Voltage 9/	0.5 VDC	2 VDC	4 VDC	4.5 VDC	20 VDC		
Pick-Up Current, Max (75 ms) 6/ 7/	3.9 A	1.6 A	0.97 A	3.6 A	0.9 A	2.2 A +/-10%	0.55 A +/-10%
Coil Current 7/	0.23 A	0.097 A	0.042 A	0.13 A @12 VDC 0.07 A @24 VDC	0.04 A @48 VDC	0.5 A +/-10%	0.13 A +/-10%
Coil Power 7/	2.8 W	2.3 W	2 W	1.7 W	1.9 W		
Coil Resistance (+/- 5% @ 25C)						5.3 Ohms	83 Ohms
Internal Coil Suppression							
Coil Back EMF	55 V	55 V	125 V	0 V	0 V	N/A	N/A
Transients, Max (13 ms)	±50 V	±50 V	±75 V	±60 V	±100 V		
Reverse Polarity	16 V	32 V	64 V	100 V	100 V		



DIMENSIONS AND CURRENT CARRY RATINGS

Auxiliary Leads

B=SPST-NO

Blue Lead = T1

White Lead = T2

C=SPST-NC

Orange Lead = T1

White Lead = T2

(Refer to Part Number System on page 4)

Coil Leads

Red Lead = X1(+)

Black Lead = X2(-)

(Refer to Part Number System on page 4)

Mounting

M5 or No. 10 Screws

Torque 15-35 in-lb (1.7-4 Nm)

Power Connection

Stainless M8x1.25 stud

Stainless M8x1.25 nut

Stainless lock washer

Stainless flat washer

Torque 90 in-lb (10 Nm) max

Power Contacts

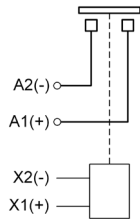

Auxiliary contacts (optional)

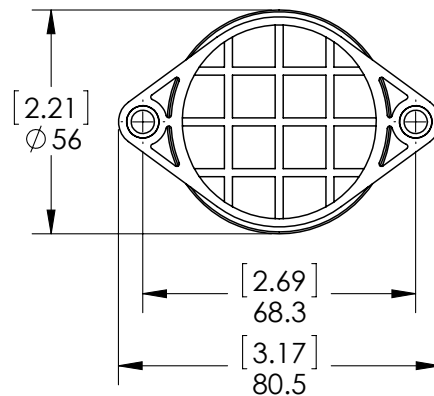
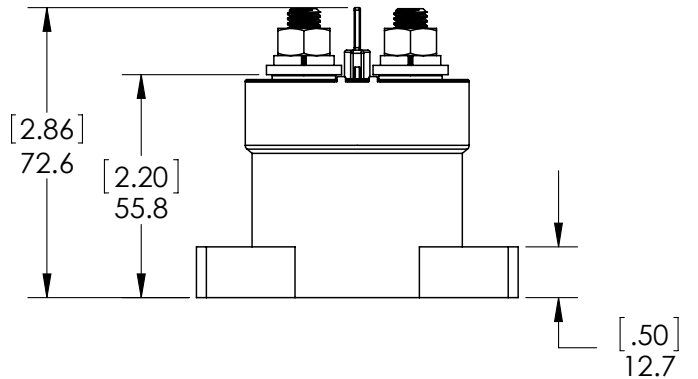
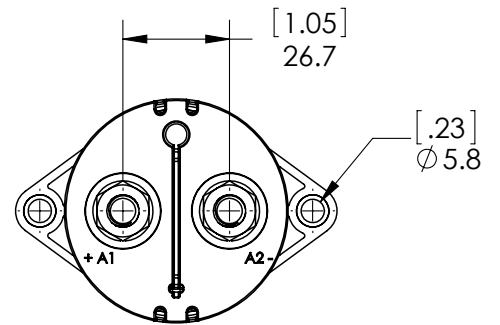
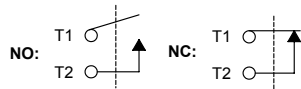

CURRENT CARRY vs TIME with 85°C terminal temperature rise

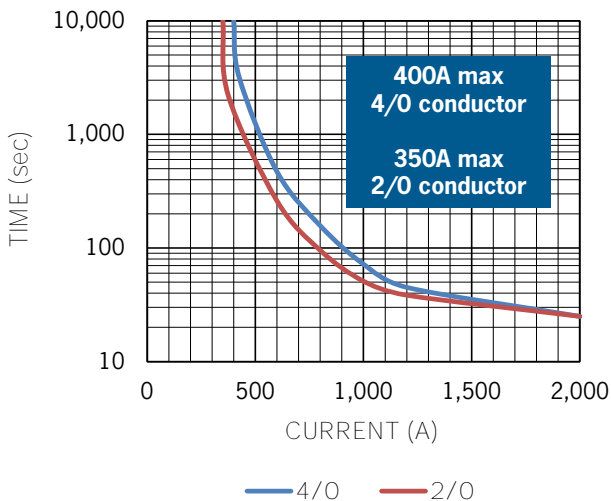

PART NUMBER SYSTEM

GV200	B	C	B	-1
Coil Voltage	B = 12 Vdc, internal coil suppression			
	C = 24 Vdc, internal coil suppression			
	F = 48 Vdc, internal coil suppression			
	M = 12/24 Vdc PWM			
	N = 48 Vdc PWM			
	P = 12/24 Vdc 4/			
	Q = 48 Vdc 4/			
Coil Termination		A = Flying leads 38 cm (15 in)		
		B = Flying leads 61 cm (24 in)		
		C = Flying leads 122 cm (48 in)		
Auxiliary Contacts			Blank = None	
			B = SPST-NO Normally Open	
			C = SPST-NC Normally Closed	
Power Contacts				-1 = High Voltage Contacts

Notes & Definitions:

- 1/ Auxillary contact rating - 2A, 24Vdc Resistive load, 100,000 cycles. Minimum current is 1mA, 5V. The auxiliary contact is mechanically linked to the main power contacts.
- 2/ 50 Mohms after life.
- 3/ Contactor can operate up to 125°C in special cases - contact GIGAVAC for details.
- 4/ Customer must provide an external economizer that meets the Pick-up Current, Coil Current, and Pick-up Current Time. For detailed information click here [Application Note AN-016](#) or visit www.gigavac.com/support/application-pp.html.
- 5/ Because the contactor is operated by a coil that changes resistance with temperature, the maximum coil voltage will be lower than indicated at temperatures above 25C, and higher than indicated at temperatures below 25C.
- 6/ Contactor has two coils. Both are used for pick-up, and then in approximately 75 milliseconds, one coil is electronically removed from the coil drive circuit. The remaining coil supplies low continuous hold power sufficient for the contactor to meet all of its specified performance specifications. This provides the lowest coil power possible without the use of PWM electronics that have been known to cause EMI emissions and/or cross-talk on your system control power.
- 7/ Because the contactor is operated by a coil that changes resistance with temperature, and because Nominal Coil Voltage has been assumed for the Pick-up Current, Coil Current and Coil Power specifications, Current/Wattage will be lower than indicated at temperatures above 25C and higher than indicated at temperatures below 25C.
- 8/ For Pick-up testing of contactors with dual coils, the voltage can not be ramped up slowly, but must be applied instantly to at least the maximum Pick-up Voltage or Current. Otherwise, the contactor will not pick-up.
- 9/ Because the contactor is operated by a coil that changes resistance with temperature, Pick-up Voltage and Drop Out Voltage will be lower than indicated at temperatures below 25C and higher than indicated at temperatures above 25C.
- 10/ These DC coils have built-in coil suppression. The use of additional external coil suppression can slow the release time and invalidate the life cycle ratings, or can cause the contactor not to be able to interrupt the maximum current specified. If lower coil back EMF is required, please contact GIGAVAC for assistance.
- 11/ All contact ratings and coil versions may not be UL recognized. Contact GIGAVAC for a copy of the applicable sections of the test report.

APPLICATION NOTES

Contactors feature internal transorb for coil suppression. No external diodes should be added across the coil.

Contactors should be installed so that current flows from A1(+) to A2(-). Breaking current in the reverse direction will reduce cycle life estimates, please consult factory for specific application assistance.

Applications with capacitors will require a pre-charge circuit.

Electrical life rating is based on resistive load with 27µH maximum inductance in circuit. Because your application may be different, we suggest you test the contactor in your circuit to verify life is as required.

End of life is defined as when the dielectric, insulation resistance or contact resistance exceeds the specifications listed.