

**PWM Controller of High-performance Current Mode****Product Specification****GENERAL DESCRIPTION**

PWM controller of high-performance current mode is specially designed for AC/DC transformer with high performance and price ratio, which supplies continuous output power of 18W within the range of wide-voltage between 85V and 265V, the output power of peak value can be up to 24W. The combination of optimized reasonable circuit design and bipolar facture technology with high performance and price ratio economizes the whole cost ultimately. The power controller can be applied to the typical fly-back circuit topology so as to form a simple AC/DC transformer. When the output power is lower, IC will reduce the working frequency automatically, therefore, the standby power consumption becomes extremely low. When the power tube is closed, the interior circuit will bias it reversely, utilize the characteristic of high pressure resistance CB of bipolar transistor directly, and improve its pressure resistance capacity to the high voltage of 700V, which ensures the security of the power tube.

Meanwhile, the perfect function of overload and saturation prevention is provided inside of IC, which can keep away some abnormal status, such as overload, saturation of transformer, and output short circuit, so as to improve the reliability of the power supply. The current limit and clock frequency can be set up by exterior components.

Now the standard encapsulation and the environmental protection leadless encapsulation that meets European standard of DIP8 are supplied.

**FEATURES**

- Set-in high-voltage power switch tube of 700V and few peripheral components
- With the modulation of lock pulse width, the testing is according to the pulse limit current.
- With the function of output frequency reduction, the non-output power consumption can be less than 0.3W.
- Inner-built ramp and anti-feedback compensation function
- The independent upper-limit current testing controller deals with over-current and over-load of the controller real-timely.
- The period emission pole is turned off and it outputs by deflected voltage, and the pressure resistance of the power tube is improved.
- Set-in current limit resistance with temperature compensation, which makes the current limit precise
- Set-in heat protection circuit
- Startup is accomplished with the magnification function of the switch power tube, and the power consumption of startup resistance is reduced more than 10 times.
- Few peripheral components
- Low startup and operating current
- VCC over-voltage automatic limit
- Continuous wide-voltage output power reaches 18W, and the output power of peak value arrives at 24W.
- Compatible with **THX203/RM6203**

**APPLICATIONS**

- Adaptor (for example, travel charger, out power station)
- Open Frame (such as electromagnetic oven, microwave oven and etc.)



**GENERAL INFORMATION**

**Pin Configuration**

The pin map is shown as below for DI8.

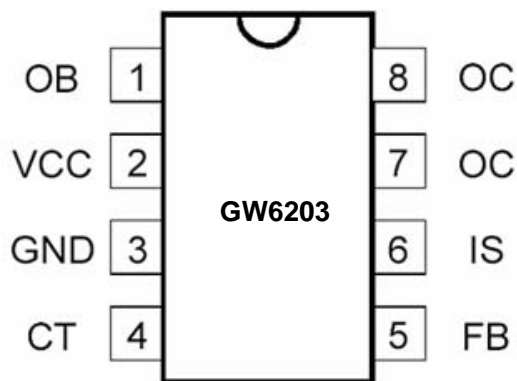

**Absolute Maximum Ratings**

Parameter	Value
Power supply voltage VCC	16V
Startup input voltage	16V
Pins input voltage	VCC+0.3V
Endurance voltage of OC collector	-0.3-V700
Switching current of peak value	800mA
Total dissipation power	1000mW
Operating temperature range	0 - +125C
Deposit temperature range	-55 -
Welding temperature	+260C,10S

**TERMINAL ASSIGNMENTS**

Pins	Symbol	Pins Description
1	OB	base electrode of power tube, control terminal of start-up current, external startup resistance
2	VCC	supply electric pins
3	GND	meet grounding pins
4	CT	oscillate capacitance pins, external timing capacitance
5	FB	feedback pins
6	IS	switching current sampling and limit enactment, sampling resistance of external current
7,8	OC	output pins, meet switching transformer

**OUTPUT POWER TABLE**

Product	230VAC±15%	85-264VAC	Package
	Open Frame	Open Frame	
<b>GW6203</b>	15W	12W	DIP8
<b>GW6206</b>	24W	18W	DIP8

**BLOCK DIAGRAM**

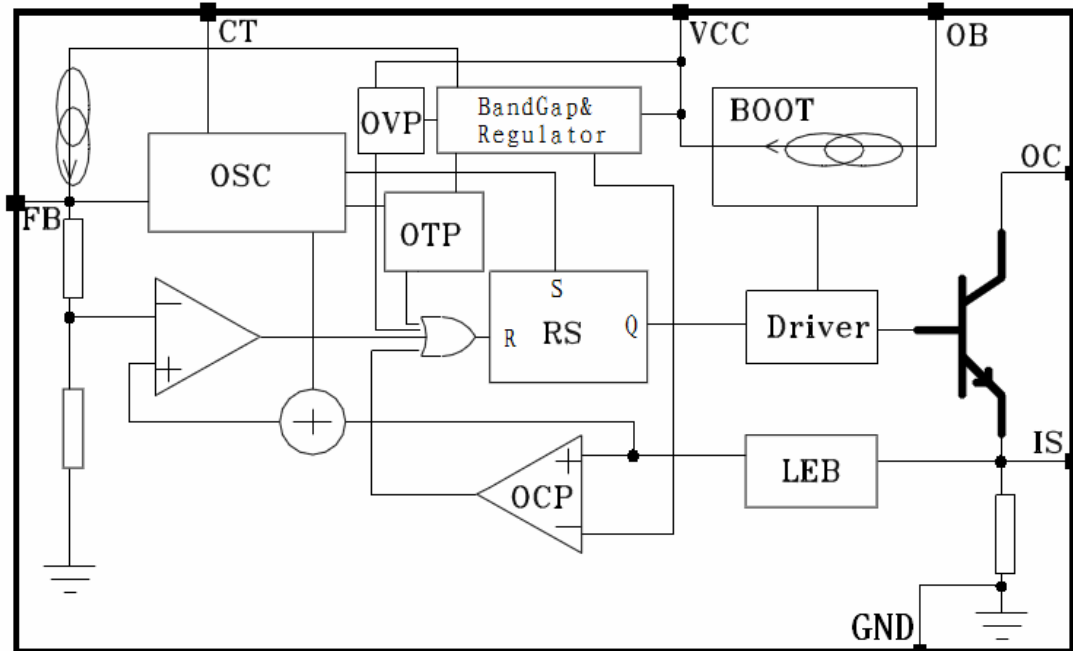

## PWM Controller of High-performance Current Mode

### Product Specification

#### ELECTRICAL CHARACTERISTICS

(TA = 25°C, VCC = 5.5-5.7V, Ct=680pF, Rs=1ohm , if not otherwise noted)

Parameter	Symbol	Conditions	Min	Typ	Max	Units
<b>Output Section</b>						
Max. Withstanding Voltage of the Switching Tube		IOc=10mA	800			V
Saturation Voltage	V <sub>SAT</sub>	IoC=250mA			1	V
Output Rise Time	TR	CL=1nF			75	ns
Output Fall Time	TF	CL=1nF			75	ns
Output Limiting Current		Tj=0-100°C	250	270	290	mA
<b>Reference Section</b>						
Reference Output Voltage	VREF	Io=1.0mA	2.4	2.5	2.6	V
Line Regulation		Vcc=5.5-9V		2	20	mV
Load Regulation		Io=0.1-1.2mA			3	%
Temperature Stability				0.2		mV/°C
Output Noise Voltage		F=10Hz-10KHz			50	uV
Long Term Stability		1000 hours@85°C		5		mV
<b>Oscillator Section</b>						
Oscillating Frequency	F <sub>osc</sub>	Ct=680PF	56	61	67	KHz
Voltage Stability		Vcc=5.5-9V			1	%
Temperature Stability		Ta=0-85°C			1	%
Oscillator Amplitude (Vp-p)				2.2		V
<b>Feedback Section</b>						
Input Impedance	Pull-up Current	FB=2.5V, IS=0V	0.55	0.6	0.65	mA
	Pull-Down Resistor					
Power Supply Suppression Ratio		Vcc=5.5-9V		60	70	dB
<b>Current Sampling Section</b>						
Current Sampling Threshold	V <sub>CS</sub>		0.55	0.60	0.65	V
Anti-Upper Limit Current	I <sub>L</sub>		0.25	0.27	0.29	A
Power Supply Suppression Ratio				60	70	dB
<b>PWM Section</b>						
Maximum Duty Ratio	D <sub>MAX</sub>		53	57	61	%
Minimum Duty Ratio	D <sub>MIN</sub>				3.5	%
<b>Power Supply Current Section</b>						
Initiating Reception Current			1.6	2.4	3.2	mA
Initiating Static Current				55	80	uA
Static Current	I <sub>o</sub>	Vcc=8V	2.8	3.0	3.2	mA
Start-up voltage			8.6	8.8	9.0	V
Oscillator Turn-off Voltage			4.4	4.6	4.8	V
Re-enabling voltage			3.6	3.8	4.0	V
Over-Voltage Limiting Threshold			9.5	10	10.5	V

**Note:**

The GW6203 is guaranteed to meet performance specifications from 0°C to 70°C. Specifications over the -40°C to 85°C

operating temperature range are assured by design, characterization and correlation with statistical process controls.

## PWM Controller of High-performance Current Mode

### Product Specification

#### OPERATION DESCRIPTION

- During start-up phase, the inner-reference voltage is closed when electrified; FB pull-up power source is closed, the start-up current is input from OB to VCC through BOOT circuit; when the voltage of VCC goes up to 8.8V, BOOT circuit stop working and not charge VCC, the start-up phase is ended, and it comes into the normal phase.
- During normal phase, VCC voltage shall keep at 4.8~9.0V, the inner-reference voltage (VR) is 2.5V benchmark; FB pull-up current source starts up; the oscillator output OSC1 decides the maximum duty cycle, output OSC2 tries to touch off the power supply to enter open cycle to enter the open cycle, and shield flashing peak current of the power tube ; if FB is less than 1.8V (about between 1.2-1.8V), the cycle of the oscillator will increase with it, the less FB is, the wider the cycle of the oscillator is, until the oscillation stops (This characteristic reduces the standby power consumption of the switching power.) ; if the peripheral feedback tries to make VCC more than 9.6V, the in-circuit is fed back to FB and makes VCC stabilize the voltage at 9.6V (According to this Characteristic, we can may not adopt peripheral feedback circuit, and stabilize the output voltage by in-circuit, but the precision of stabilizing voltage is low); During the open cycle, OB supplies base current for the power tube, OE pulls down the emitter of the power tube to IS, and OB adopts the driving parameter of ramp current ( it refers to that OB on-current is the

parameter of IS, when IS is 0V, OB on-current is about 40mA, then OB on-current increases linearly with IS, when IS increases to 0.6V, OB on-current is about 120mA, this characteristic makes effective use of the output current of OB, decreases the power consumption of GW6203H, if IS detects that the specified current FB, it will come into the close cycle; during the close cycle, OB pulls down, the power tube will not shut off immediately, but OE clamps 1.5V (after the power tube is shut off, the base will be biased reversely, which improves the voltage endurance); during open or close cycle, if the power tube is detected beyond the upper limit current, the trigger of the upper limit current will be placed preferentially and forces FB to drop, the duty cycle will become less so as to protect the power tube and transformer; at the beginning of next close cycle or when FB is less than 1.8V, the trigger of the upper limit current will reset. In addition, GW6203H is installed over heat protection internally, when the internal temperature is higher than 140°C, it will broaden the cycle of the oscillator and makes the temperature of GW6203H less than 150°C ; The ramp compensation is also placed internally, when GW6203H is in a big duty cycle or in the mode of constant current, it can stabilize the open/close cycle.

- If VCC declines to 4.3V or so, the oscillator will shut off, OSC1 and OSC2 are in the low level, and the power supply keeps at close cycle; when VCC goes on declining to 3.7V or so, GW6203H will come into the start-up phase once again.

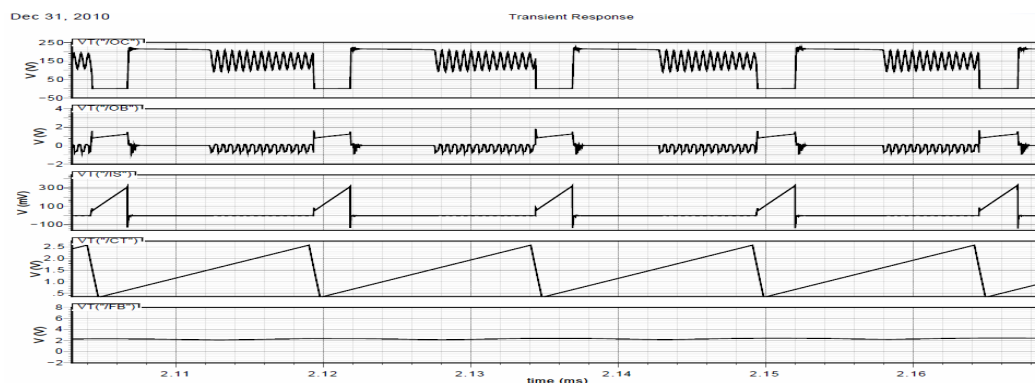

## PWM Controller of High-performance Current Mode

### Product Specification

#### Electric Parameter Definitions

- Start-up receives current: The current of OC when there's a 0.5mA pull down current of OB in the start-up period.
- Start-up static current: The minimum current sourcing current which can enable VCC surging when VCC is connected to a filter capacitor and an adjustable current sourcing, CT is connected to a 680pF capacitor, and other pins with no connection.
- Start-up voltage: The maximum of VCC above.
- Re-start-up voltage: The minimum of VCC above.
- Oscillator shut-down voltage: The negative-edge of VCC above; the value of VCC which can stop the oscillator.
- Static current: The VCC power supply current in normal period when FB is connected to the ground by a 1.0K $\Omega$  resistance.
- Oscillator pull up/pull down current: The pull up/pull down current of CT when FB=2.5V and CT=1.25V in normal period.
- FB pull up current: which occurs in normal period, when FB=2.5V, and IS=0A.
- FB upper current protection: The pull down current of FB when FB=6V and IS=0.6A in normal period.
- Inside feedback power supply: The value of VCC when there is no feedback circuit of GW6203 in normal period.
- OC upper limit current: If FB=6V, the minimum OC current when there is pull down current in FB.
- Oscillator cycle: Which is the function of the capacitor connected to CT, about CT\*25400 seconds.

#### Power Supply Design Points

- Current control switching power supply with fly-back design, discontinuous current operation mode.
- The power supply start-up current is 0.5-2mA which is alternative. The magnification of power transistor Q1 can be supposed as 10. Then the alternation of the start-up resistance must assure the current of the power transistor's base is between 0.05mA to 0.2mA. Therefore, the power of the output resistance can reduce to 1/10, which reduces the power in idle state.
- In diagram 3, C3=680pF, the maximum operation frequency is about 67KHz.
- The reference winding rectifier output is 4.8~9.0V (6V is recommended) of the Switching transformer (T1 in diagram 3), which provide operation power for GW6203.
- The maximum primary peak current of the switching transformer is 0.6A. When at wide voltage or 110V Vac, or 85V magnetism dissipation voltage, the maximum output power can achieve more than 12W.
- The OC (Pin 7, 8) of GW6203 is in high voltage, and IS (Pin 6, for current sense resistor) is connected. Therefore, it is easy to open a divider between pin 6 and 7 to meet the requirement of the safe regulation.
- Although there is over-temperature protection, when high-power output is needed without considering PCB heat dissipation, the output power and voltage may fall.

PACKAGE MECHANICAL DATA

8-Pin Plastic DIP

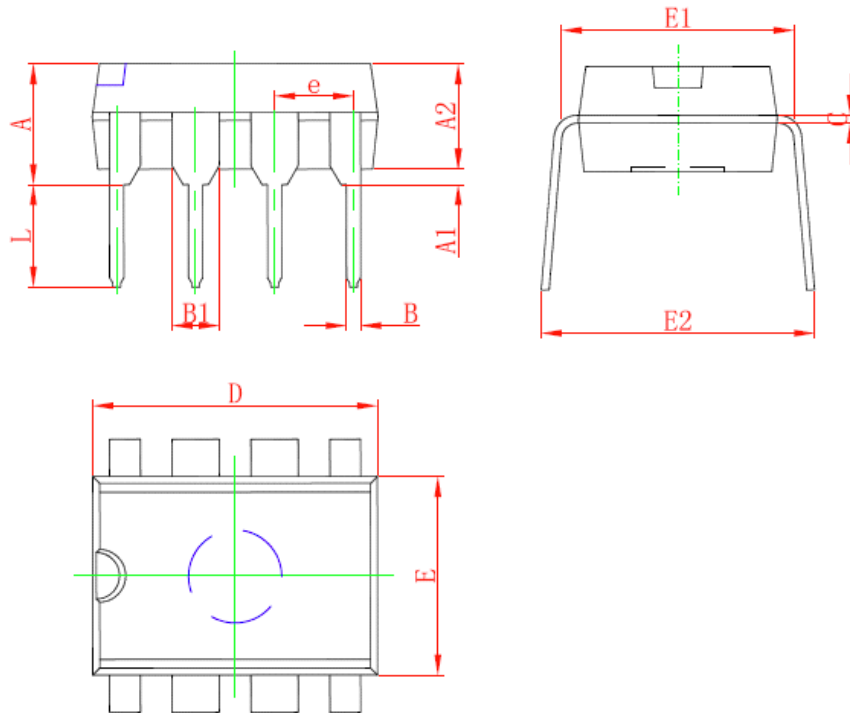

Symbol	Dimensions In Millimeters		Dimensions In Inches	
	Min	Max	Min	Max
A	3.710	4.310	0.146	0.170
A1	0.510		0.020	
A2	3.200	3.600	0.126	0.142
B	0.380	0.570	0.015	0.022
B1	1.524 (BSC)		0.060 (BSC)	
C	0.204	0.360	0.008	0.014
D	9.000	9.400	0.354	0.370
E	6.200	6.600	0.244	0.260
E1	7.320	7.920	0.288	0.312
e	2.540 (BSC)		0.100 (BSC)	
L	3.000	3.600	0.118	0.142
E2	8.400	9.000	0.331	0.354